

ELKAY® With FLEXI-GUARD®

INSTALLATION & USE MANUAL

SWIRLFLO® Fountains with FLEXI-GUARD® and EZH₂O® Bottle Filler

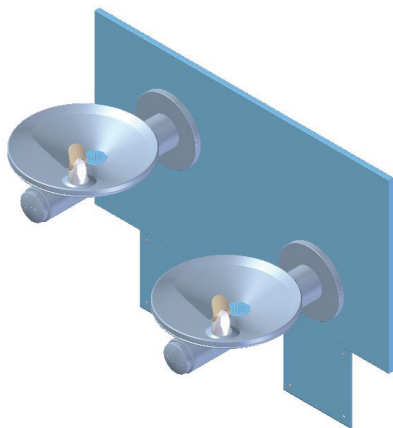

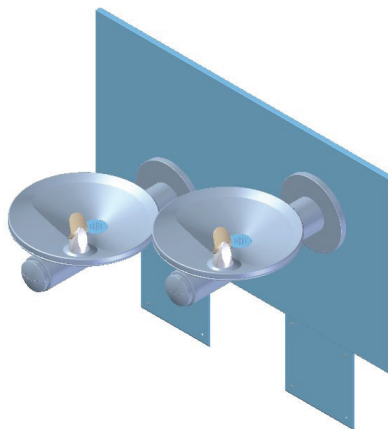

EDFPBM(V)117C



EDFPBM(V)117RAC

INSTALLER

-  **CAUTION:** Review these instructions before beginning installation. Be sure that installation conforms to all plumbing, electrical and other applicable codes.
-  **WARNING:** When installation is complete, ensure these instructions are left in the plastic bag provided inside the installed unit for future reference.
-  **WARNING:** Service to be performed by authorized service personnel only.

NOTE: It is common practice to ground electrical hardware such as telephones, computers and other devices to available water lines. This can, however, cause electrical feedback in the plumbing circuit, which results in an “electrolysis” effect occurring in the fountain. This may result in water which has a metallic taste to it or has a noticeable increase in the metallic content of the water.

When inspecting plumbing circuit, remember the line may be grounded some distance from the installation, and may occur outside the building or area in which the unit is being installed.

This condition can be avoided (in most cases) by using recommended materials during installation. Any drain fittings provided by the installer should be made of **plastic** which will electronically isolate the fountain from the remainder of the building’s plumbing circuits.

Patent zurn-elkay.com/patents

 **WARNING:** Cancer and Reproductive Harm - www.P65Warnings.ca.gov

 **ADVERTENCIA:** Cáncer y daño reproductivo - www.P65Warnings.ca.gov

 **AVERTISSEMENT:** Cancer et effets néfastes sur la reproduction - www.P65Warnings.ca.gov

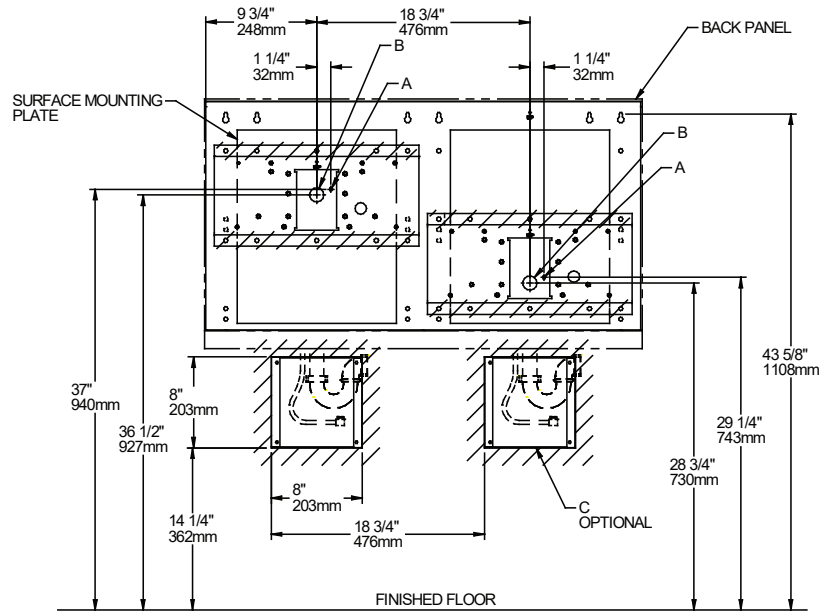
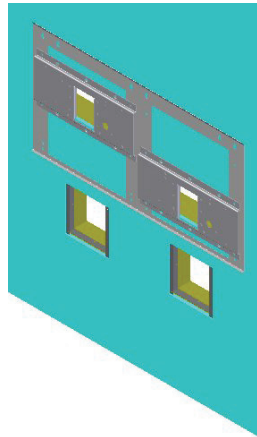
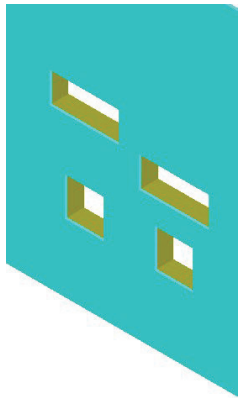

Figure 1 - Rough-in EDFPBM(V)117C

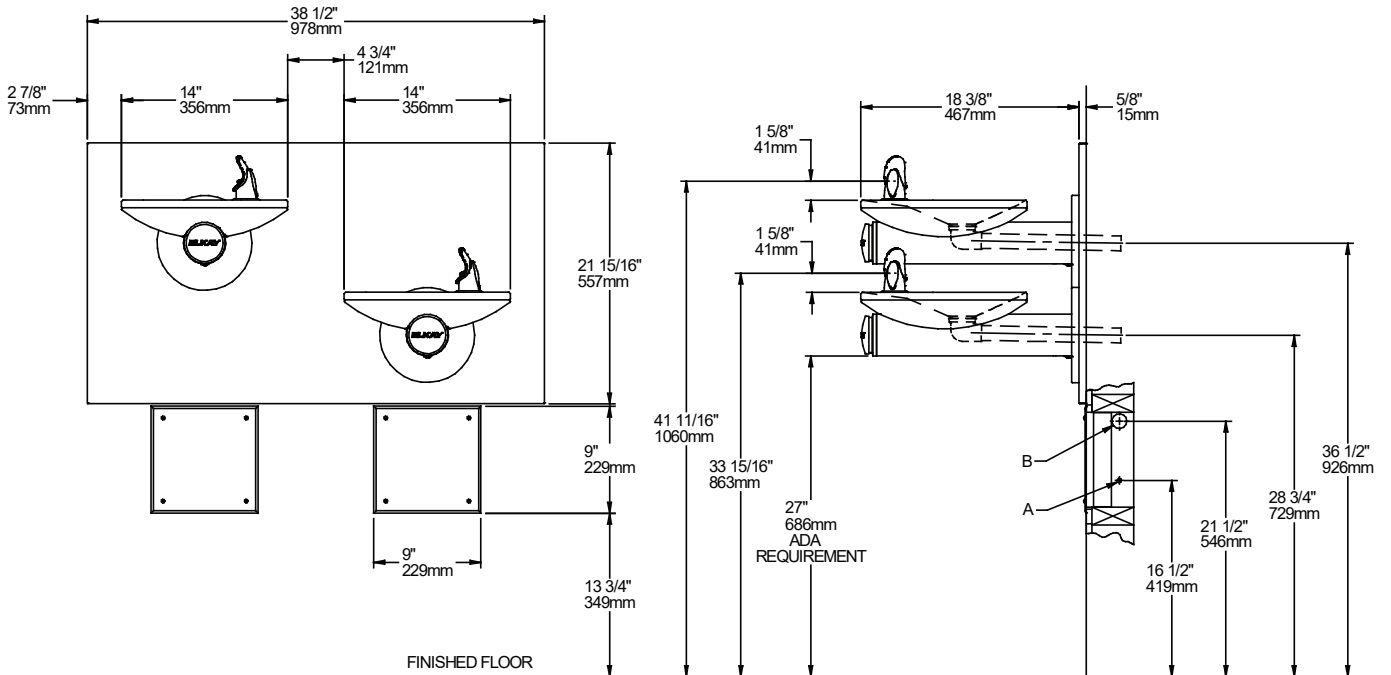

Figure 2 - Rough-in Assembly EDFPBM(V)117C

LEGEND

- A = Water Inlet Location Left Or Right Side. 3/8" O.D. Unplated Copper Tube Connect.
- B = Fountain Waste Location Left Or Right Side. Waste Is Shown in Wall But May Be Behind Wall. 1-1/4" O.D. Drain (Trap Not Furnished)
- C = Opening For Optional AP-99 Access Panel

Note: Reinforce The Wall In The Shaded Areas.

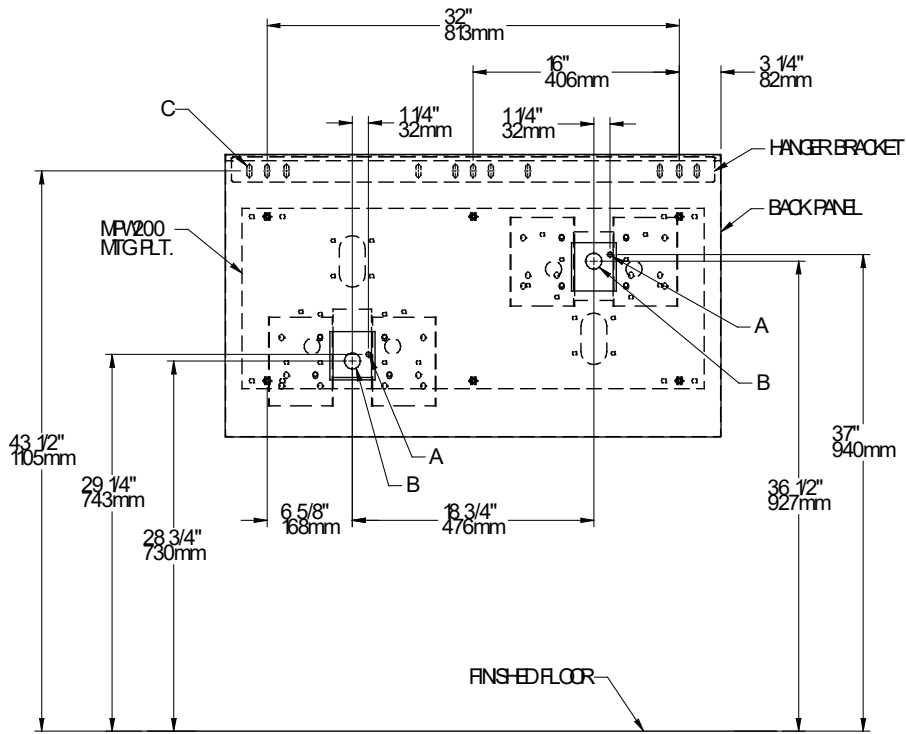

Figure 7 -Rough-in EDFPB(V)117RAC

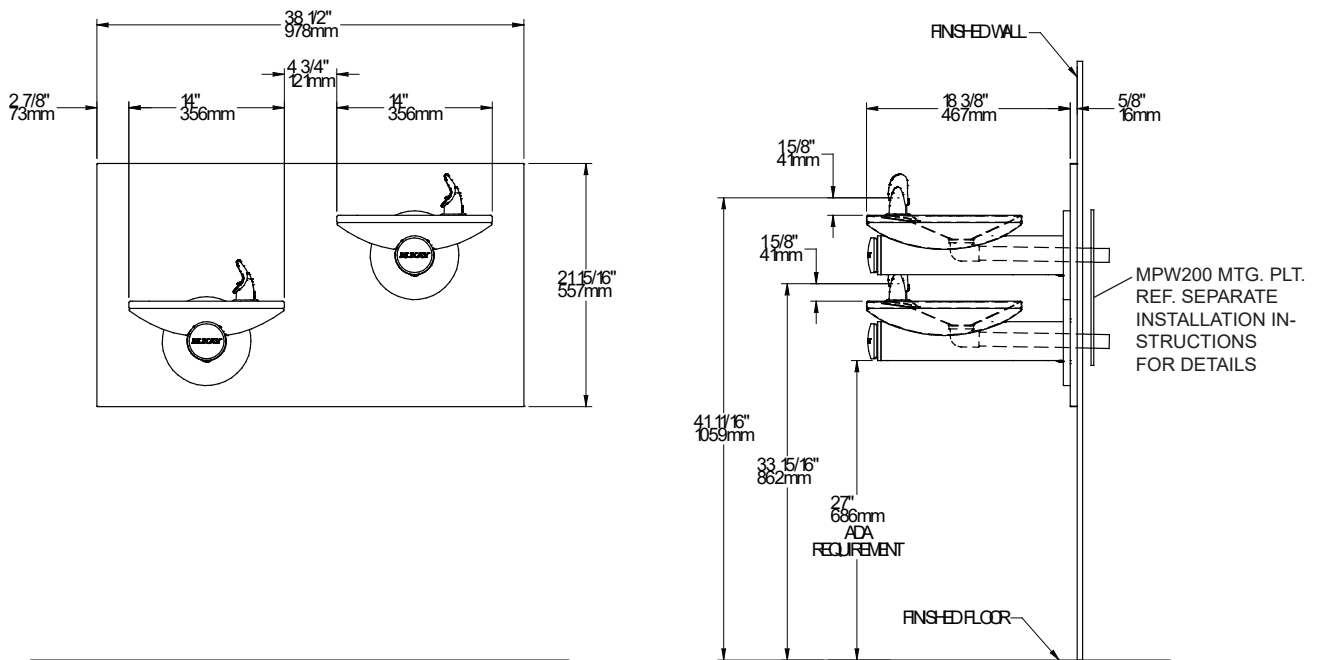

Figure 8 -Rough-in Assembly EDFPB(V)117RAC

LEGEND

- A = Water Inlet Location Left Or Right Side. 3/8" O.D. Unplated Copper Tube Connect.
- B = Fountain Waste Location Left Or Right Side. Waste Is Shown in Wall But May Be Behind Wall. 1-1/4" O.D. Drain (Trap Not Furnished)
- C = 3/8" (10mm) DIA. Slots For Mounting Hanger Bracket To Wall

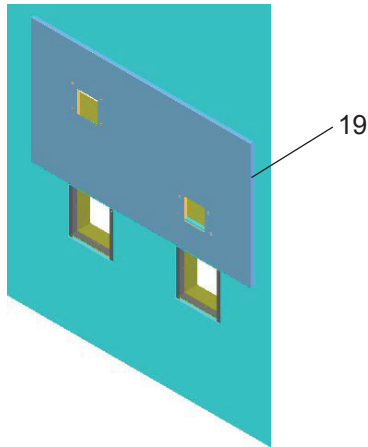

Figure 9 - Panel Installation

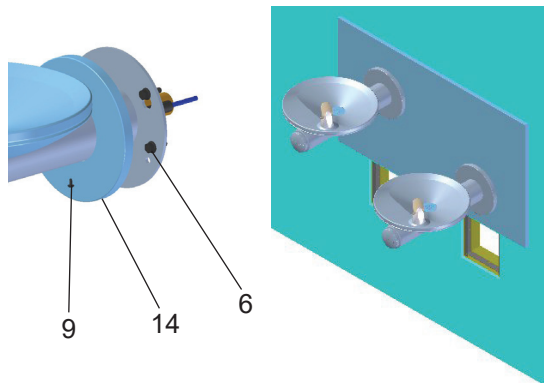

Figure 10 - Fountain Installation

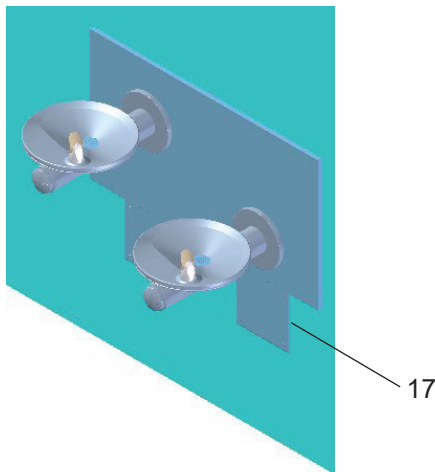

Figure 11 - AP-99 Panel (Optional)

Installation Instructions:

1. **Fountains using the MPW Mounting Plate** refer to Figures 5 or 7 for hanger bracket location and rough-in dimensions.
NOTE: Review separate installation instructions for details of the MPW Mounting Plate.
Fountains using the Wall Plate Assy. refer to Fig's. 1 or 3 for rough-in dimensions.
2. Shown dimensions pertain to installation location (framing must support up to 300 lbs. weight). These dimensions are required for compliance with ANSI Standard A117.0.
3. **Install** rough-in plumbing as shown in Fig's. 1, 3, 5, or 7. Run supply water inlet line through the back panel. Install a service stop (not provided). Turn on supply water and flush thoroughly.
4. **Installing back panel.**
Ftn. w/MPW Mounting Plate: Refer to Fig. 16 for placement of braces onto back panel. Place the upper edge of the panel above the hanger bracket. Slide the panel down until it engages the hanger bracket. Be sure back panel is firmly engaged before releasing it.
Ftn. w/Wall Plate Assy.: Place the upper edge of the panel above mounting plate on the wall. Slide the panel down until it engages the mounting plate. Be sure back panel is firmly engaged before releasing it. (See Figure 9)
5. **Install fountain.** Remove screw (Item 9) from cover plate and slide cover plate (Item 14) toward basin. (See Figure 10)
Ftn. w/MPW Mounting Plate: Mount the fountain to the back panel and wall using (4) 5/16" x 6" long threaded rods, washers, and nuts (provided). Tighten securely.
Ftn. w/Wall Plate Assy.: Mount the fountain to the back panel and wall plate assy. with (4) 5/16" x 1" (25mm) long screws (Item 6 - provided). Tighten securely.
6. **Determine** required length of waste line and cut to appropriate length. 1-1/4" O.D. waste tube furnished. 1-1/4" slip trap, waste elbow and extension not provided.
7. **Make water** supply connections from service stop to the 3/8" O.D. unplated copper tube coming out of the strainer. Turn on water supply and check for leaks (See Figure 17). Newly installed water supply line should be insulated after leak check is completed.

CAUTION: DO NOT SOLDER tubes inserted into the strainer as damage to the o-rings may result.

8. **These** products are designed to operate on 20-105 PSI supply line pressure. If the inlet pressure is above 105 PSI, a pressure regulator must be installed in the supply line. Any damage caused by reason of connecting these products to supply line pressures lower than 20 PSI or higher than 105 PSI is not covered by warranty. __
9. **Check** stream height from bubbler. Stream height is factory set at 35 PSI. If supply pressure varies greatly from this, remove push button (Item 16 - Figure 14) and adjust the screw on the regulator (Item 18 - Figure 14). To remove push button, remove setscrew from bottom of sleeve (Item 15). Insert a small punch in screw hole and push up while grasping the push button and pull forward removing the push button. Clockwise adjustment will raise stream height and counterclockwise movement will lower stream height. For best adjustment stream should hit basin approximately 6-1/2" from the bubbler. Reassemble the push button by pushing in on button until the push button catches in the sleeve. Reinstall the setscrew (Item 5) in the sleeve (Item 15).

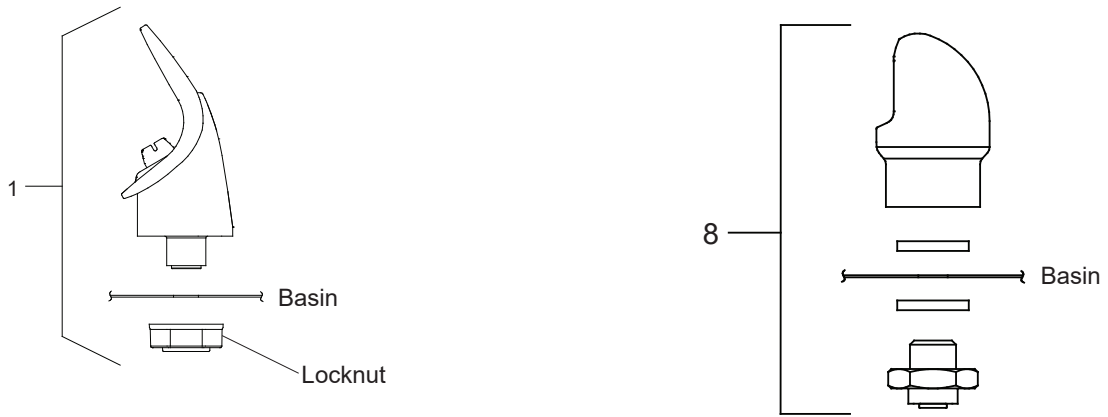

NOTE:
When installing replacement bubbler and pedestal, tighten locknut only to hold parts snug in position. **Do Not overtighten.**

Figure 12 - Bubbler Details

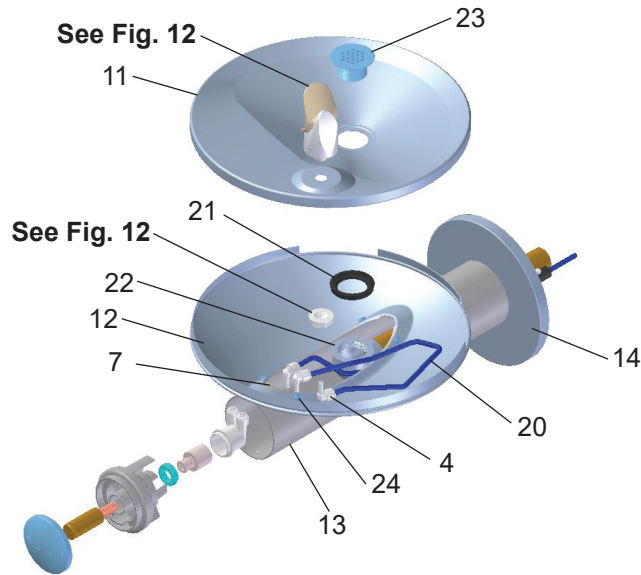

Figure 13 - Fountain Body

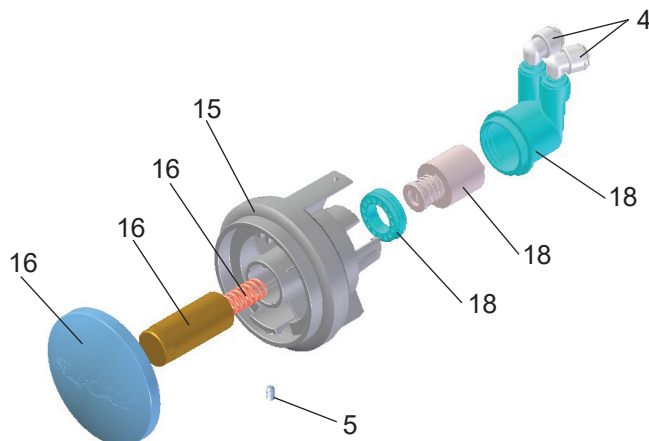

Figure 14 - Push Button

PARTS LIST		
ITEM NO.	PART NO.	DESCRIPTION
1	56073C	Bubbler Assy
2	28844C	Back Panel Assy RH ADA
	28845C	Back Panel Assy LH ADA
3	55996C	Strainer
4	70817C	Ftting - Elbow 1/4 x 1/4
5	75632C	Setscrew - #10-32 x .31
6	75560C	Screw - 5/16-18 x 1.00 HHMS
7	38417001	Screw - #8-18 x .37 HHSM
8	98118C	Bubbler Assembly VR
9	70432C	Screw - #8-32 x .38 THSM
10	111008343890	Screw - #10-24 x .62 HHMS
11	28708C	Basin - Swirlflow
12	28473C	Lower Shell
13	45767C	Fountain Body
14	28343C	Cover Plate
15	45781C	Sleeve
16	98871C	Kit - Pushbutton/Spring/ AP-99 Panel (Optional)
17	AP99	AP-99 Panel (Optional)
18	98530C	Kit - Regular/Holder/Nut
19	28844C	Back Panel Assy RH ADA
	28845C	Back Panel Assy LH ADA
20	56092C	Poly Tubing (Cut To Length)
21	56163C	Gasket - Drain
22	0000000930	Assy - Drain/Tailpipe
23	45768C	Drain - Plug 1-1/2"
24	70288C	Screw - #10X.37 HHSM
NS	27090C	Hanger Bracket

NS = NOT SHOWN

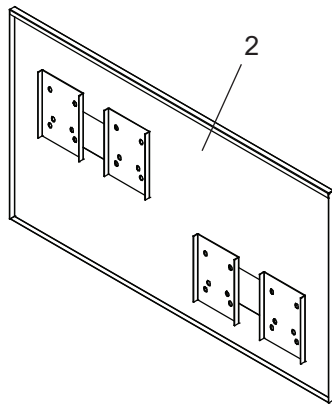

Figure 16 – Back Panel Assembly

Installing Back Panel: When installing back panel assy. (Item 2) with MPW (Mounting Plate), attach channel braces as shown above. Remove the protective backing from the tape installed on the braces. Line up the corresponding holes in the braces and back panel and press firmly in place.

TROUBLESHOOTING & MAINTENANCE

Orifice Assembly: Mineral deposits on orifice can cause water flow to spurt or not regulate. Mineral deposits may be removed from the orifice by poking with a small round file not over 1/8" diameter, or using a small diameter wire.



CAUTION: DO NOT file or cut orifice material.

Stream Regulator: If orifice is clean, regulate flow as in Step 8 of the installation instructions. If replacement is necessary, see parts list for correct regulator part number.

Actuation of Quick Connect Water Fittings: Cooler is provided with lead-free connectors which utilize an o-ring water seal. To remove tubing from the fitting, relieve water pressure, push in on the gray collar while pulling on the tubing. (See Figure 15) To insert tubing, push tube straight into fitting until it reaches a positive stop (approximately 3/4").

OPERATION OF QUICK CONNECT FITTINGS

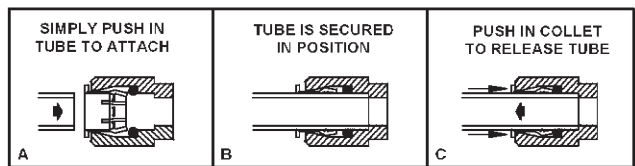

PUSHING TUBE IN BEFORE PULLING IT OUT HELPS TO RELEASE TUBE

Figure 15 – Quick Connect Fittings

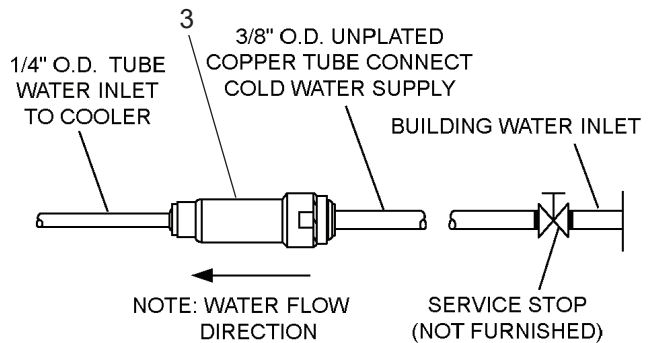
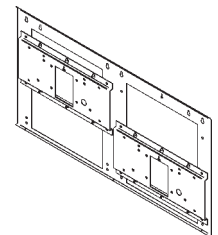
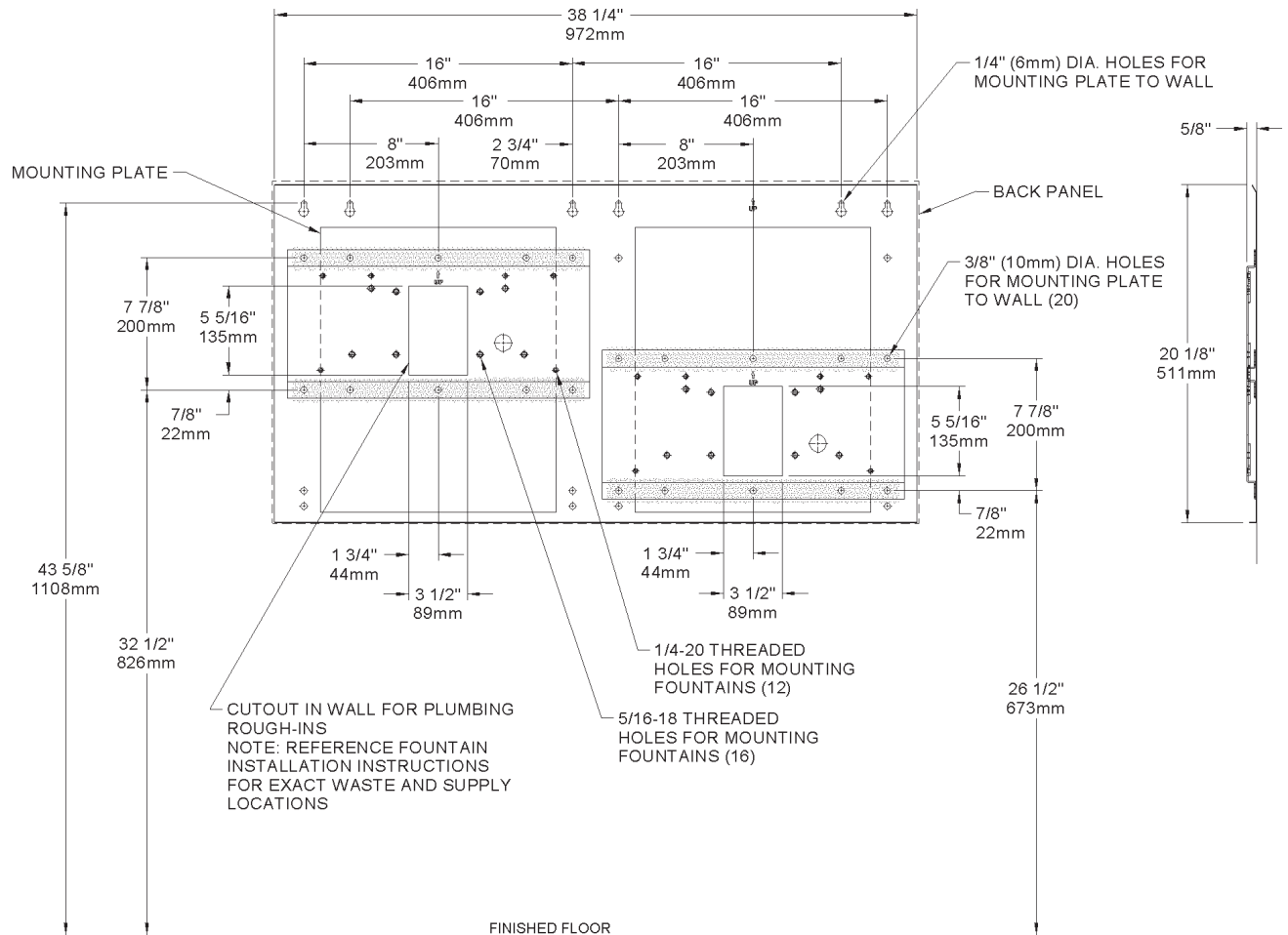

Figure 17 – Water Supply Connections

MP20 MOUNTING PLATE INSTRUCTIONS



- 1. Remove mounting plate from packaging. Read this instruction sheet before proceeding.**
These dimensions are required to obtain proper rim and bubbler heights for compliance with ANSI standard A117.1.
- 2. Install plumbing rough-ins** as per fountain instructions (supplied with fountain).
- 3. Install (2) 1/4" (6mm) screws** (not provided) into wall at 43 5/8" above finished floor. Use the two best hole locations for your application. Hang mounting plate on these screws and level mounting plate before tightening screws.
- 4. Reinforce the wall in shaded areas** for framed wall construction so that it will adequately support the water fountain. This reinforcement must support up to 300 lbs static load and provide a means for securing the mounting plate in place.
- 5. Attach mounting plate** to finished wall surface with (12) 5/16" x 2" long bolts and flat washers, 6 per bracket (not provided). Tighten securely. (Fastener must match wall type, i.e. lag screws for wood studs, bolts and anchors for masonry construction.)

MP20RA MOUNTING PLATE INSTRUCTIONS

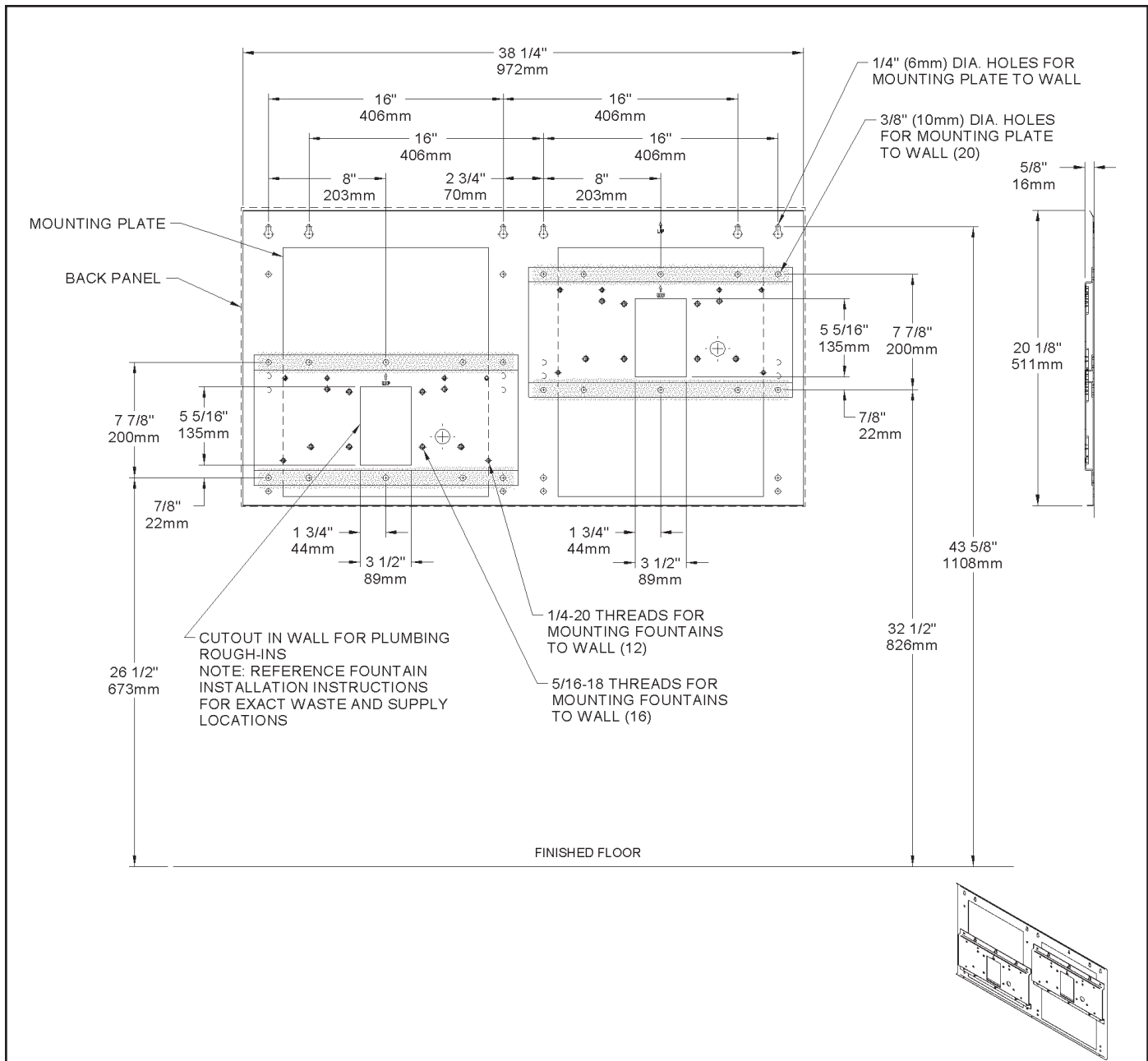

- 1. Remove mounting plate from packaging. Read this instruction sheet before proceeding.**
These dimensions are required to obtain proper rim and bubbler heights for compliance with ANSI standard A117.1.
- 2. Install plumbing rough-ins** as per fountain instructions (supplied with fountain).
- 3. Install (2) 1/4" (6mm) screws** (not provided) into wall at 43 5/8" above finished floor. Use the two best hole locations for your application. Hang mounting plate on these screws and level mounting plate before tightening screws.
- 4. Reinforce the wall in shaded areas** for framed wall construction so that it will adequately support the water fountain. This reinforcement must support up to 300 lbs static load and provide a means for securing the mounting plate in place.
- 5. Attach mounting plate** to finished wall surface with (12) 5/16" x 2" long bolts and flat washers, 6 per bracket (not provided). Tighten securely. (Fastener must match wall type, i.e. lag screws for wood studs, bolts and anchors for masonry construction.)