

# BLACK DIAMOND®

Project Name: \_\_\_\_\_

Location: \_\_\_\_\_

Item #: \_\_\_\_\_

Qty: \_\_\_\_\_

## Black Diamond Gas Deep Fryer, Natural Gas, 50 lb, 120K BTU, in Stainless Steel

### BDGF-120/NG



Delivering exceptional performance in commercial kitchens, this Black Diamond Gas Deep Fryer is crafted from stainless steel and cast iron, ensuring durability and efficiency. It features a 50-pound capacity, ideal for high-volume cooking of french fries, chicken wings, and more. Operating within a temperature range of 200° to 400°F, it offers precise control for perfect frying. Equipped with manual ignition and control, this fryer is designed for ease of use and maintenance, making it a reliable choice for professionals.

### FEATURES AND CONSTRUCTION

- Constructed with durable stainless steel and cast iron
- Delivers a powerful 120,000 BTUs for efficient frying
- Equipped with 4 burners for versatile cooking options
- Offers a 50 lb capacity for high-volume frying needs
- Includes casters for mobility
- Includes standard coupling adaptor and gas connection for natural gas
- Features manual ignition and control for precision cooking
- Temperature range of 200° to 400°F for versatile cooking
- Designed for high-volume commercial kitchen environments
- Perfect for frying a variety of foods like french fries and chicken wings

### FRYER ACCESSORIES (OPTIONAL)

- Stainless Steel Cover
- Joiner Strips
- Splash Guard
- Fryer baskets available in a variety of sizes

### 3RD PARTY APPROVALS

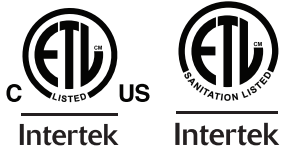

### WARRANTY (USA / CANADA)

One (1) Year Limited Warranty on Parts and Labor, Five (5) Year Warranty on Stainless Steel Fry Tank

Contact us for details at 1.877.368.2797



### INCLUDED COMPONENTS

- (4) Casters
- (2) Baskets
- (1) Basket Support Rack
- (1) Basket Hanging Plate
- (1) Oil Drainage Extension Pipe

### TEMPERATURE

Overall Temperature (Fahrenheit):

- Minimum: 200° - Maximum: 400°F



# Black Diamond Gas Deep Fryer, NG, 50 lb, 120K BTU

**BDGF-120/NG**

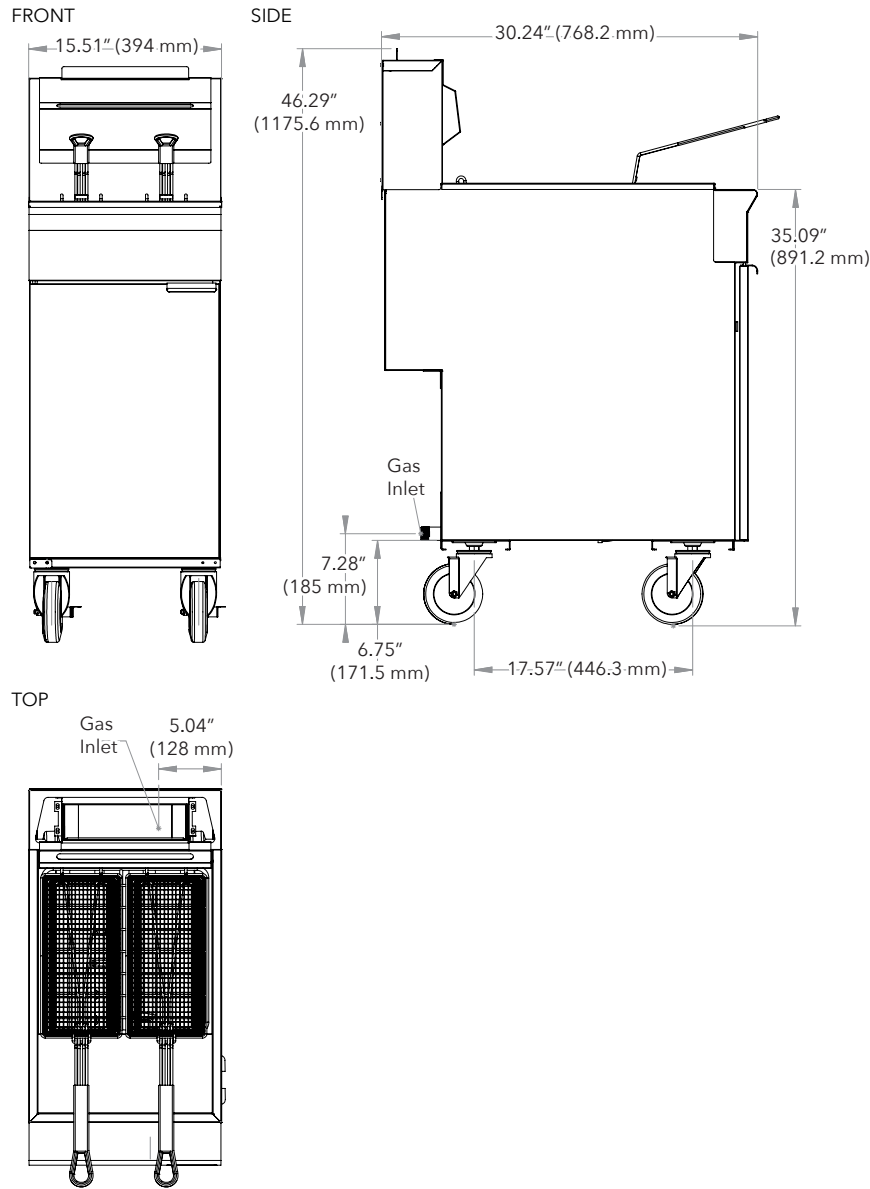

## Gas

Capacity (lbs. of oil)	Temperature Range (Fahrenheit)	BTU / Hour	Assembled Dimensions (in)	Item Weight (lbs)	Shipping Weight (lbs)
50 lbs	200° - 400°	120000	30.24" x 15.51" x 46.29"	145.5	172.0

## ADDITIONAL INFORMATION

- Electricity not needed.
- Liquid Propane (LP) or Natural Gas (NG) units available. Field convertible from LP to NG and vice versa.
- Minimum supply pressure is 4" W.C. for natural gas and 10" W.C. for propane.
- Gas powered appliances must always be indoors, under an approved exhaust system with grease removal filters and a fire protection system.

Due to periodic changes in designs, methods, procedures, policies and regulations, the specifications contained in this document are subject to change without notice. While we exercise good faith efforts to provide information that is accurate, we are not responsible for errors or omissions in information provided or conclusions reached as a result of using the specifications. By using the information provided, the user assumes all risks in connection with such use.