

Innovative Designs Inspiring Change.

Mosaic™ Series

Create and Communicate Your
Perfect Program

Product Data Sheet | Version 1.9

U.S. Patents: US 1052840
Canadian Patents: CA 220422; CA 233706;
CA 233707; CA 232344
European Patents: 015035507-0001;
015035507-0002; 015035507-0003
U.K. Patents: 6315806; 6315807; 6315808

Busch Systems International Inc.
81 Rawson Avenue, Barrie ON., Canada
1.800.565.9931
buschsystems.com



View the Mosaic™ Series Online!





CREATE AND COMMUNICATE YOUR PERFECT PROGRAM

The Mosaic™ is a versatile, modular recycling and waste container system designed for durability and flexibility. It features customizable signage, secure bag retention clips, and an optional lockable caster kit for easy, safe relocation. Expand your capacity by adding more units with the interlocking connector system, and choose from a variety of lid openings and colors to support effective waste diversion. Perfect for public spaces and workplaces, the Mosaic makes collection effortless, efficient, and stylish.

Now Available: The Mosaic™ Junior — a shortened version of the original Mosaic designed for kid-friendly spaces. With the same smart features as the original, the Mosaic Junior includes accessible access and engaging, kid-focused signage to support early waste diversion habits.



Liners and Black Lids are made from 100% post-consumer recycled content

POPULAR SKU'S



209814



209817



209845



216508

www.buschsystems.com • 1.800.565.9931 • 81 Rawson Avenue, Barrie, Ontario, Canada L4N 6E5

BUILD YOUR MOSAIC™ STATION

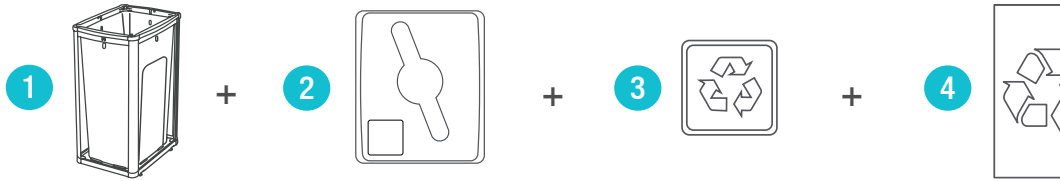

ONE: THE BODY

- Standard (32 Gallon)
- Junior (21 Gallon)

TWO: THE LID

- See lid opening specifications for available openings

THREE: THE LABEL

- Choose from our stock options or customize your own!

FOUR: OPTIONAL KITS

- Sign Panels (Wide & Narrow)
- Connector Kits
- Caster Kits
- Back Sign Frame Kit
- Bag Wranger™



BODY SPECIFICATIONS

Below are the available Body Options for the Mosaic™ Series. With this measurement guide you will find the right size Mosaic™ container to fit your space. The measurement guide is the essence of various standard measuring methods. All measurements are in inches. Talk to your dedicated Busch Systems® sales representative for more information on how to choose the right size container for your space.

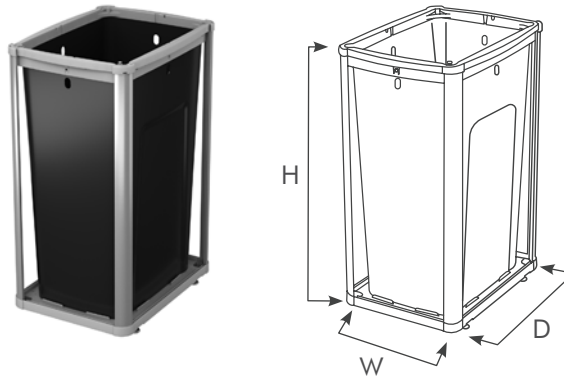

Body Shape	Height	Width	Depth	Weight	Capacity
Standard	32.375"H (822.3 mm)	15.74"W (399.8 mm)	20.86"D (529.8 mm)	20.8lbs (9.43 kg)	32 gal
Junior	26.85"H (682 mm)	15.74"W (399.8 mm)	20.86"D (529.8 mm)	17lbs (7.71 kg)	21 gal

STOCK BODY COLORS



Executive Grey

Body Frame



Anodized Aluminum

Corner Extrusions



Black

100% PCR Liner

STOCK BAG HOOKS



Purple

STOCK SIGN FRAME KIT COLORS



Silver

Sign Frame Bracket



Anodized Aluminum

Extrusion

LID OPENING SPECIFICATIONS

The chart below outlines the available Lid Opening Options for each Mosaic™ body as well as the associated opening dimensions. Be sure to run a preliminary audit of the popular materials that are discarded where your Mosaic™ containers will be placed. For example, if you're collecting large quantities of standard-sized Cans & Bottles, the Circle Opening is the ideal choice, as it will reduce contamination of materials that are larger than the dimensions of the opening. If there is a blank cell on the body or lid style of your choice, this means there is currently no stock option available. Talk to your dedicated Busch Systems® sales representative for more information.

	Full	Mixed	Slot	Circle	Solid-Lift	Vented-Lift
Mosaic™						
Opening Dimensions	11.125"W x 12.5"D	1.75"W x 11.25"D 5"W (circle)	1.75"W x 11.75"D	5.5" Diameter	7.5"W x 12.5"D	7.5"W x 12.5"D

STOCK LID COLORS



Royal Blue



Dark Green



Executive Grey



Black



Red*

*Available in select lids only.



Yellow*



Silver**

**Available in Full lid only.

PRODUCT ACCESSORIES

If you're interested in maximizing the full potential of your Mosaic™ containers, you can enhance the quality & performance and expand the possibilities with top quality accessories that will add functionality and convenience with ease. These product accessories are designed to help you get the most out of your recycling & waste management equipment. Busch Systems® offers a number of different accessories to add convenience and portability.

To add movement to your Mosaic™ station, consider the Busch Systems® professional quality wheel casters that allow you to easily move your station to a better location or for cleaning and maintenance. Additionally, the connector kit is a unique expansion system that allows you to add or remove bodies from your Mosaic™ stations at any time.

For more customization, the Mosaic™ bodies are compatible with a vast choice of customizable body signage and label options that increase stream visibility.

Maximize your messaging with our new elevated back sign frame. Placed higher on your Mosaic™ containers, it enhances visibility to help users sort correctly and reduce stream contamination. Standard single sign frames are stocked to preserve your Mosaic™ station's modular flexibility. For a more unified look, custom-width sign frames are also available to connect containers into a cohesive unit. Talk to your dedicated Busch Systems® sales representative for more information.

The Bag Wrangler is designed to cinch and secure oversized waste bags inside your Mosaic container. By holding excess material firmly in place against the integrated corner hooks, it prevents the bag from slipping into the bin and maintains a tidy, streamlined appearance.

NEW!

BAG WRANGLER

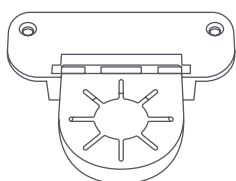

SIGN FRAME KIT

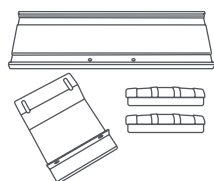

(1 per container)

CONNECTOR KIT

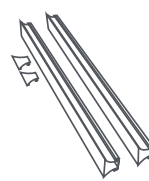

(connect 2 units together)

WHEEL CASTER KIT

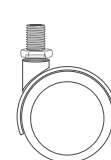

(set of 4 lockable wheel casters)

STOCK GRAPHICS

To clearly indicate streams, all signage and labels are available in corresponding stream colors. All signage and labels are customizable. Ask your Busch Systems® Sales Representative about all available sign panel and label artwork options.

STOCK MOSAIC SIGN PANELS (WIDE & NARROW CONFIGURATIONS)



STOCK MOSAIC JUNIOR SIGN PANELS (WIDE & NARROW CONFIGURATIONS)



STOCK MOSAIC LID LABELS



STOCK MOSAIC JUNIOR LID LABELS



STOCK MOSAIC SIGN FRAME INSERTS



NOTE: Because different computers, monitors, and printers render colors and textures differently, actual finishes may vary from those shown here.

IDEAL BAG SIZES

	Standard	Junior
Ideal Bag Size (inches)	36 x 39	30 x 34

MATERIAL & CONSTRUCTION DETAILS

Not all recycling & waste receptacles are created equal. Our company policy is never to compromise on our workmanship or the quality material standards we've set. We only recommend and use quality first grade materials on our recycling & waste containers, and source these from OEM's at highly-competitive prices. Being a manufacturer that buys at high-quantities gives significant buying power with companies which in turn saves you money.

The design process, materials used, finishes and manufacturing standards all affect the final product. Every decision is vital to getting the most value for your investment. You deserve recycling & waste containers that meets your demands for quality and durability and will enhance your working environment for years to come.

Component	Material(s)	Construction
Body Frame	HDPE	<ul style="list-style-type: none"> Body frames are molded from durable HDPE
Lids (color)	HDPE	<ul style="list-style-type: none"> Lids are molded from durable HDPE and contain up to 35% recycled content
Lids (black)	PCR PP	<ul style="list-style-type: none"> Lids are molded from durable black 100% Post-Consumer Recycled Polypropylene
Connector & Connector Extrusions	Anodized Aluminum	<ul style="list-style-type: none"> Individually cut to length
Liner	PCR PP	<ul style="list-style-type: none"> Liners are molded from durable black 100% Post-Consumer Recycled Polypropylene
Sign Panels	PVC Sintra	<ul style="list-style-type: none"> Sintra® PVC sheet is a lightweight, yet rigid, highly-durable expanded foam
Sign Frame Kit	Powder Coated Steel + Anodized Aluminum	<ul style="list-style-type: none"> Sign frame bracket is powder coated steel and sign frame extrusion is anodized aluminum
Bag Wrangler™	90A TPE + HDPE	<ul style="list-style-type: none"> Precision-molded in 90A TPE and HDPE
Wheel Casters	HDPE + Steel	<ul style="list-style-type: none"> Available set includes 4 durable, long-lasting locking swivel casters

ENVIRONMENTAL CONSIDERATIONS

- All Mosaic™ Receptacles use a low energy, resource efficient manufacturing and curing process
- All Mosaic™ receptacle components disassemble at end of life and are fully recyclable
- Low maintenance and extremely long service life
- Manufactured in North America
- [Product Carbon Footprint Dashboard for 1 Unit Mosaic™ Single Bin](#)

Configurations	Post-Industrial Recycled Content	Post-Consumer Recycled Content	Total Recycled Content	3rd Party Certifications
Mosaic™	Contact us	Contact us	Contact us	-

Busch Systems® is dedicated to environmental responsibility. We maintain an Environmental Management System and are continually working to improve our impact through efficiency, material selection, vendor education, employee involvement, and an unwavering commitment to being a Certified B Corporation™. If you would like additional information on our product development process or if you don't see the information you need for your project on this page, please contact our Sustainability Team at sustainability@buschsystems.com.

LEAD TIME

Our standard lead times on stock SKU's for the Mosaic™ Series are 3-5 days. Our standard lead times on large/custom orders for all Mosaic™ Series are 6-8 weeks. Please contact us to discuss your specific timing requirements.

PRICING

Please contact us at **800.565.9931** or **sales@buschsystems.com**. At Busch Systems®, we design, manufacture and sell our products directly to you. Our sales team is available to assist you with questions about our products, requests for quotes, and orders. Vertical Managers are located across North America to assist with the front-end specification and quoting process, and our in-house Project Sales Coordinators follow your project through from the time you place an order to shipment.

TO ORDER PLEASE SPECIFY

Quantity, body model, lid model, label choice and any optional product accessories. Talk to your dedicated Busch Systems® sales representative for more information. If you do not have a dedicated Sales Representative please contact us via our website at **buschsystems.com/contact-us/**

INSTALLATION

Busch Systems® Mosaic™ Series containers are hassle-free when it comes to installation. Each container is individually boxed using cardboard with high recycled content and each associated lid is boxed within the container box to ensure safe transport.

TO INSTALL YOUR MOSAIC™ CONTAINERS:

1. Unbox the body and lid components
2. Insert the recycling/waste bag into the body and wrap the top edge of the bag around the bag hooks located in the top rim of the bin
3. Place the lid on top of the body

CARE & MAINTENANCE

Advantages of Busch Systems® HDPE & LDPE receptacles include:

- Great low temperature impact resistance and excellent chemical resistance
- Great high temperature impact resistance
- Lower stiffness rating which reduces potential for stress cracking
- High strength-to-density ratio

Their appearance and lifespan will be greatly affected by their care. The frequency of cleaning required depends on the environment in which the containers are used. Outdoor containers will be subject to different environmental conditions than indoor units, i.e. sun, rain, wind, pollution, winter temperatures, and salt/sea air.

To avoid the accumulation of dirt and grime on your Busch Systems products, and help prevent corrosion, we recommend that a mild detergent be used (not an abrasive), such as a pH-neutral liquid (hand dishwashing or hand car washing soaps, for example) diluted in warm water. Wipe with a clean wet cloth and towel dry. Any dirt adhering to the powder coating should be removed. In order to remove deposits such as salt or dust, use a soft brush (non-abrasive). If this is not sufficient to remove stubborn soiling, the following products have been tested for use:

- Ajax Cream
- Liquid Gumption
- Flash (in water)
- Ajax Liquid (in water)
- Cutting compound ('T. Cut')

Note: Always test soaps/cleaners on a hidden and/or small area beforehand

If solvents are absolutely needed to remove marks, a soft cloth dampened with white spirit may be used.

THINGS TO AVOID

- Cleaners with chloride or bleach
- Solvents
- Abrasive detergents
- Steel wool or Scouring pads

Contact Us Today for a Quote on Your Mosaic™ Series Station!



www.buschsystems.com • 1.800.565.9931 • 81 Rawson Avenue, Barrie, Ontario, Canada L4N 6E5