

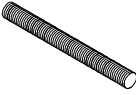









HEKMAN®

A HOWARD MILLER COMPANY

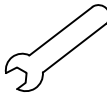
23365 QUEEN BED 23366 KING BED

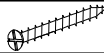
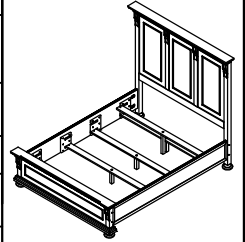
HARDWARE LIST							
A	B	C	D	E	F	G	H
BOLT M8 x 100 8 PCS.	HALF WASHER M8 8 PCS.	SPRING W. M8 8 PCS.	HEXAGONAL NUT M8 (8 PCS.)	ALLEN BOLT M6 X 40 (4 PCS.)	ALLEN KEY L4 (FOR ALLEN BOLT) 1 PC.	WRENCH KEY (FOR HEXA BOLT) 1 PC.	DOWEL Ø10 X 40 mm 4 PCS.
							
							I
							SCREW Ø8 X 1 1/2" (8 PCS.)
							

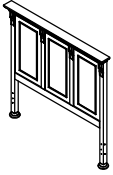
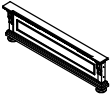
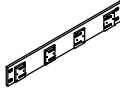

PART INSIDE				
1	2	3	4	5
HEADBOARD (1 Pc)	FOOTBOARD (1 Pc)	SIDE RAILS (2 Pcs)	SLATS (4 Pcs)	SUPPORT SLATS (8 Pcs)
				

Assembly Instruction

STEP 1:

TURN CONNECTING BOLT (A) INTO THE THREADED INSERT THAT IS FIXED IN THE HEADBOARD (1) AND FOOTBOARD (2). PLACE SIDE RAIL (3) IN POSITION AND ATTACH WITH THE HALFMOON WASHER (B), SPRING WASHER (C), HEX NUT (D) USING WRENCH KEY (G) PROVIDED.

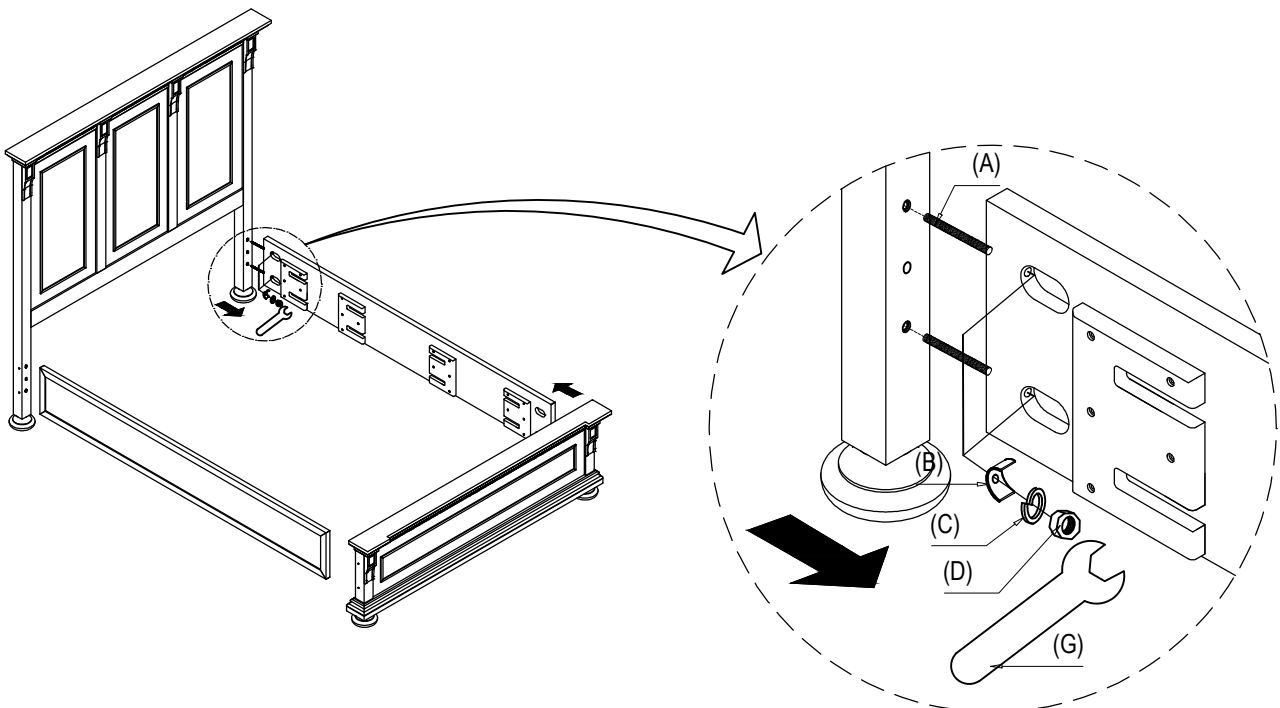

STEP 2:

PLACE SLATS IN THE WOOD RAIL BRACKET FOUND INSIDE THE SIDE RAILS USING SCREW (I) AND TIGHTEN WITH SCREW DRIVER (NOT INCLUDED).

ATTACH SUPPORT LEGS TO SLATS, ATTACH WITH ALLEN BOLT (D) AND TIGHTEN USING ALLEN KEY M4 (F).

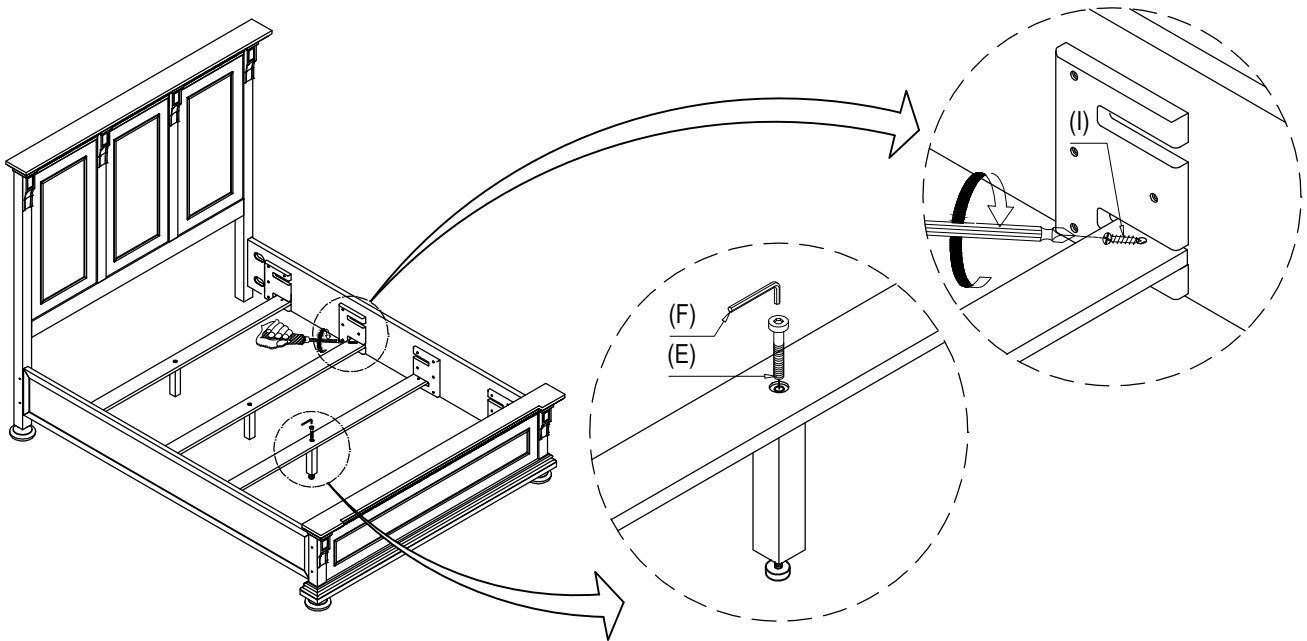

IF THE BED SUPPORTS ARE NOT LEVEL WITH THE FLOOR,
ADJUST THE ADJUSTABLE LEVELERS FOUND ON THE
BOTTOM OF THE LEG SUPPORTS.