



bestchoiceproducts



INSTRUCTION MANUAL

Foldable Wooden Adirondack Chair



bestchoiceproducts

Thank you for choosing us! Since 2002, Best Choice Products has been bringing customers high-quality products at the absolute lowest price. With everything ranging from instruments and toys to furniture and outdoor, we've got your everyday living essentials covered. We're centered around a customer-first philosophy - with free shipping, exceptional customer service, and a catalog sourced with you in mind.

! NOTICE

Please retain these instructions for future reference.

- Please do not exceed the weight limitations of this item.
- Do not stand on or use any part of this item as a step ladder.
- Firmly secure all bolts, screws and knobs before use.
- Reconfirm that all bolts, screws, and knobs are secure every 90 days.
- Fasten screws loosely during initial assembly. Do not firmly tighten the screws until the item is completely assembled.
- Do not use or store this item in the proximity of open flame or flammable/combustible chemicals.
- Be aware that some parts are heavy and have sharp edges.
- If any parts are missing, broken, damaged, or worn, stop using this product until repairs are made and/or factory replacement parts are installed.
- Do not use this item in a way inconsistent with the manufacturer's instructions as this could void the product warranty.

TOOLS REQUIRED



PHILLIPS
SCREWDRIVER



ALLEN WRENCH
(PROVIDED)



DRILL
(RECOMMENDED)



330 LBS
CAPACITY



1 PERSON
ASSEMBLY



APPROXIMATELY
45 MIN.
ASSEMBLY

HARDWARE

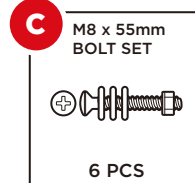
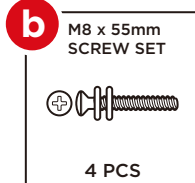
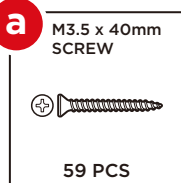

Due to large amount of screws,
use of an electric drill is highly
recommended to save time.

PARTS

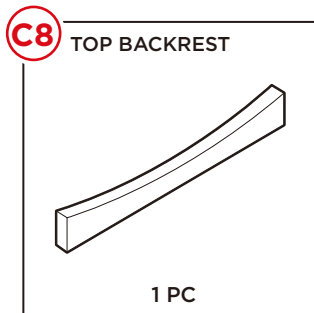
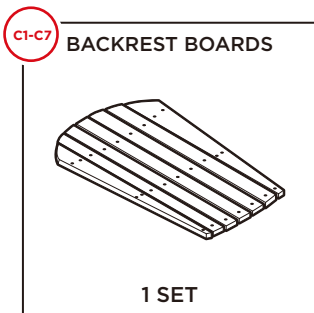
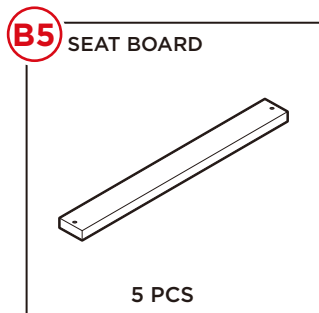
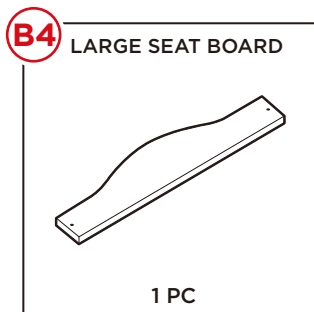
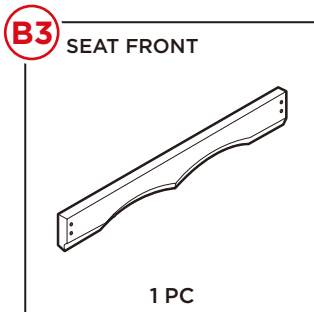
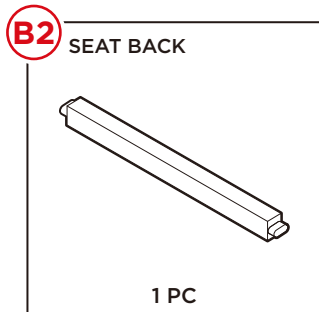
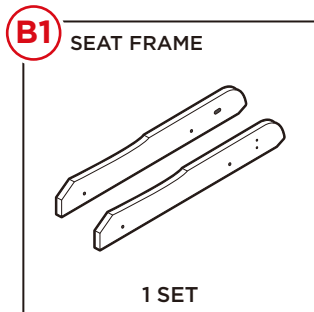
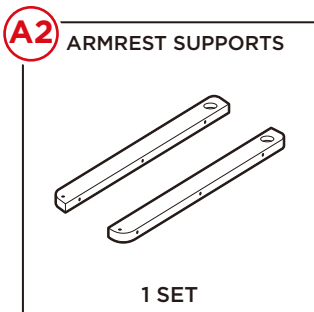
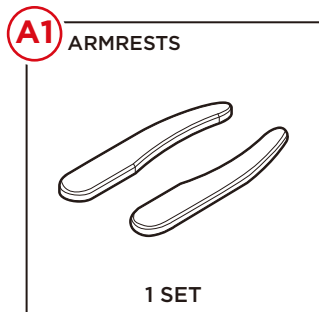

PARTS

C9

MIDDLE BACKREST

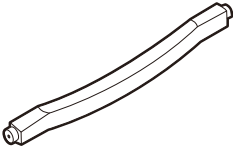

1 PC

C10

BOTTOM BACKREST

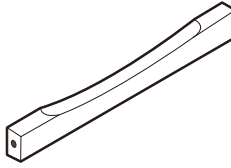

1 PC

D

TRIANGLE SUPPORT



2 PCS

E

BACKREST SUPPORT

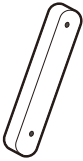

2 PCS

F1

LEGS

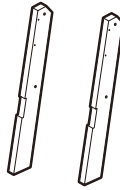

1 SET

F2

FRONT SUPPORT

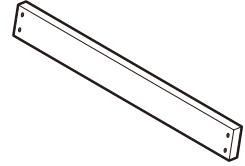

1 PC

PRODUCT ASSEMBLY

Please retain these instructions for future reference.

1

Attach part C4 backrest board to part C8 top backrest, part C9 middle backrest, and part C10 bottom backrest with three part a screws.

Attach part C1 and C7 backrest boards with ten part (a) screws.

Attach part C2, C3, C5, and C6 backrest boards with twelve part (a) screws.

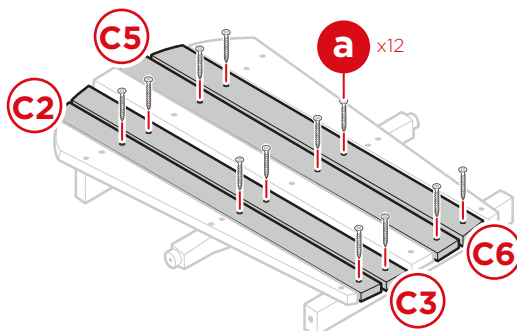
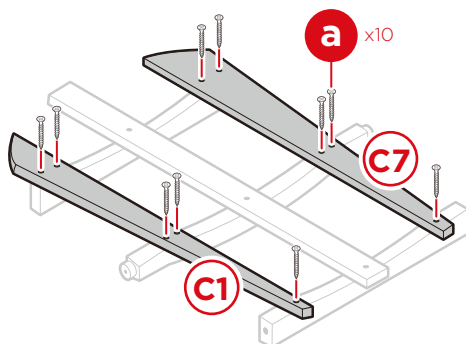
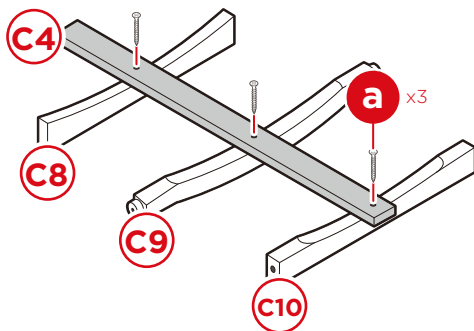

PRODUCT ASSEMBLY

2

Attach part B2 seat back and part B3 seat front to part B1 seat frame set with eight part (a) screws.

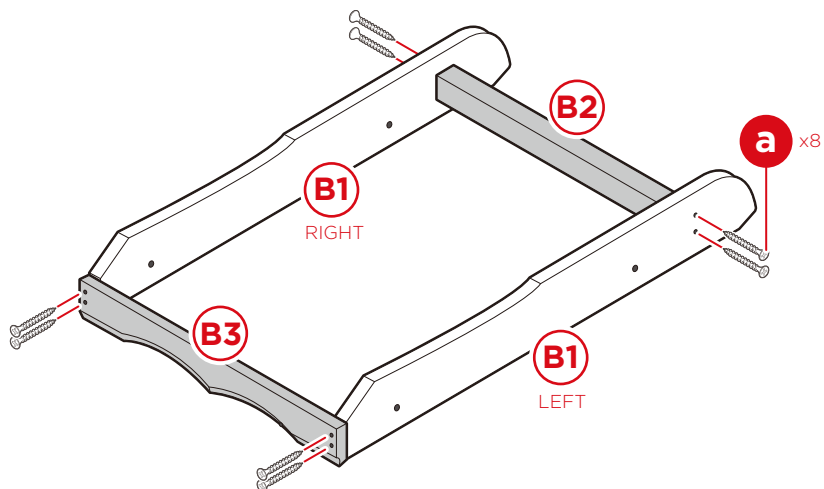

3

Attach part B4 large seat board and five part B5 seat boards with twelve part (a) screws.

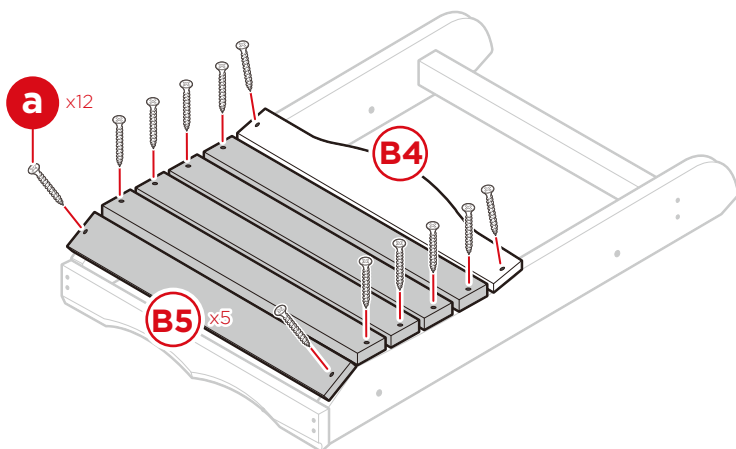

PRODUCT ASSEMBLY

4

Attach part A2 armrest support set to part A1 armrest set with six part (a) screws.

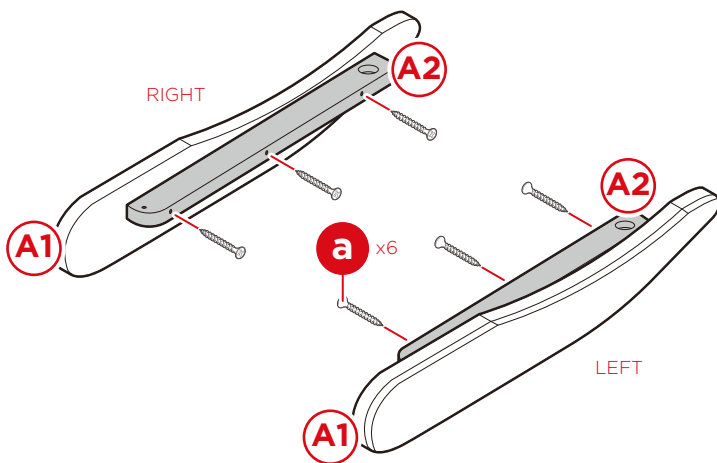

5

Attach two part D triangle supports to part F1 leg set with four part (a) screws.

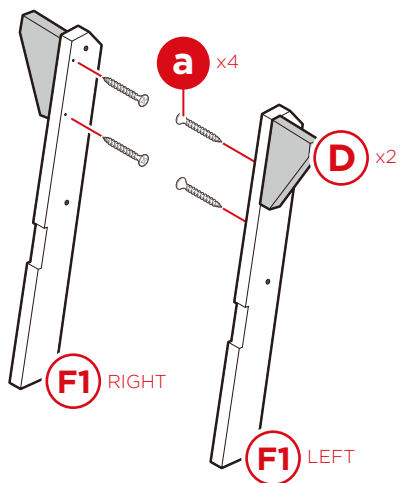

PRODUCT ASSEMBLY

6

Attach legs to the seat two part (c) bolt sets.

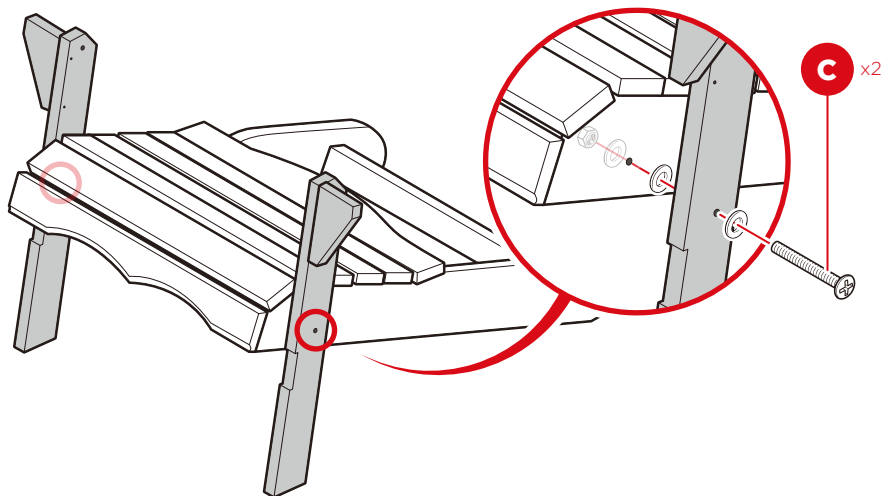

7

Attach part F2 front support with four part (a) screws.

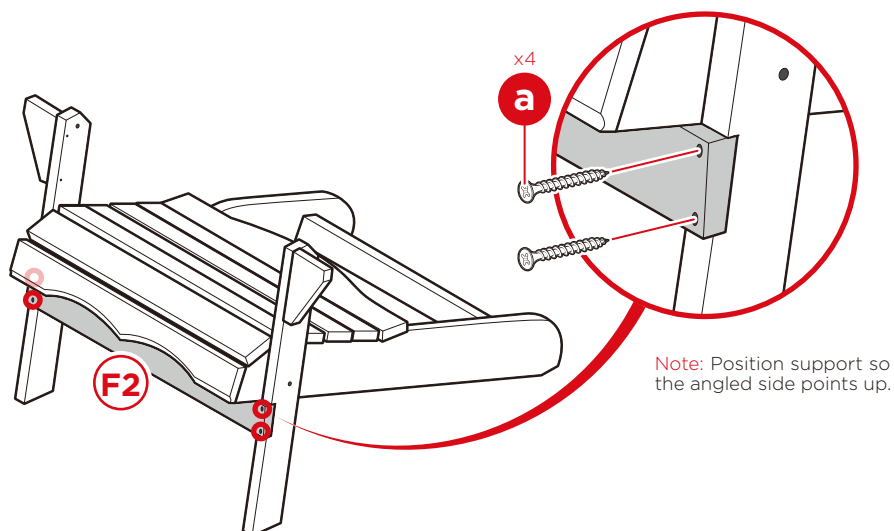

PRODUCT ASSEMBLY

8

Attach two part E backrest supports with two part (c) bolt sets, one on each side.

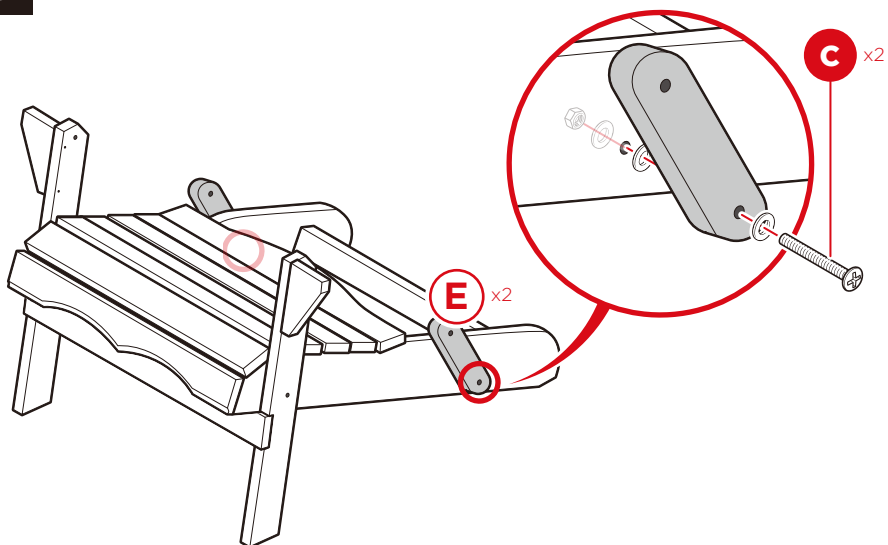

9

Attach backrest to the backrest supports with two part (b) screw sets.

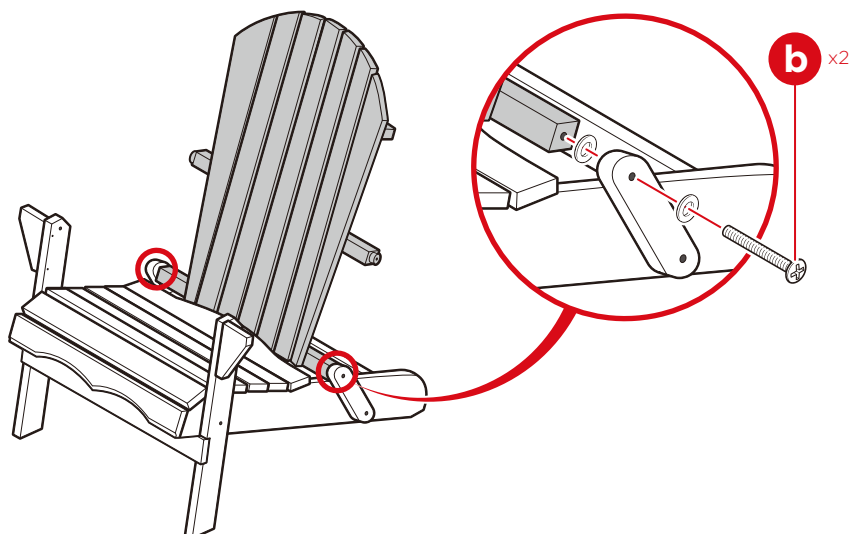

PRODUCT ASSEMBLY

10

Attach armrests with two part b screw sets and two part (c) bolt sets.

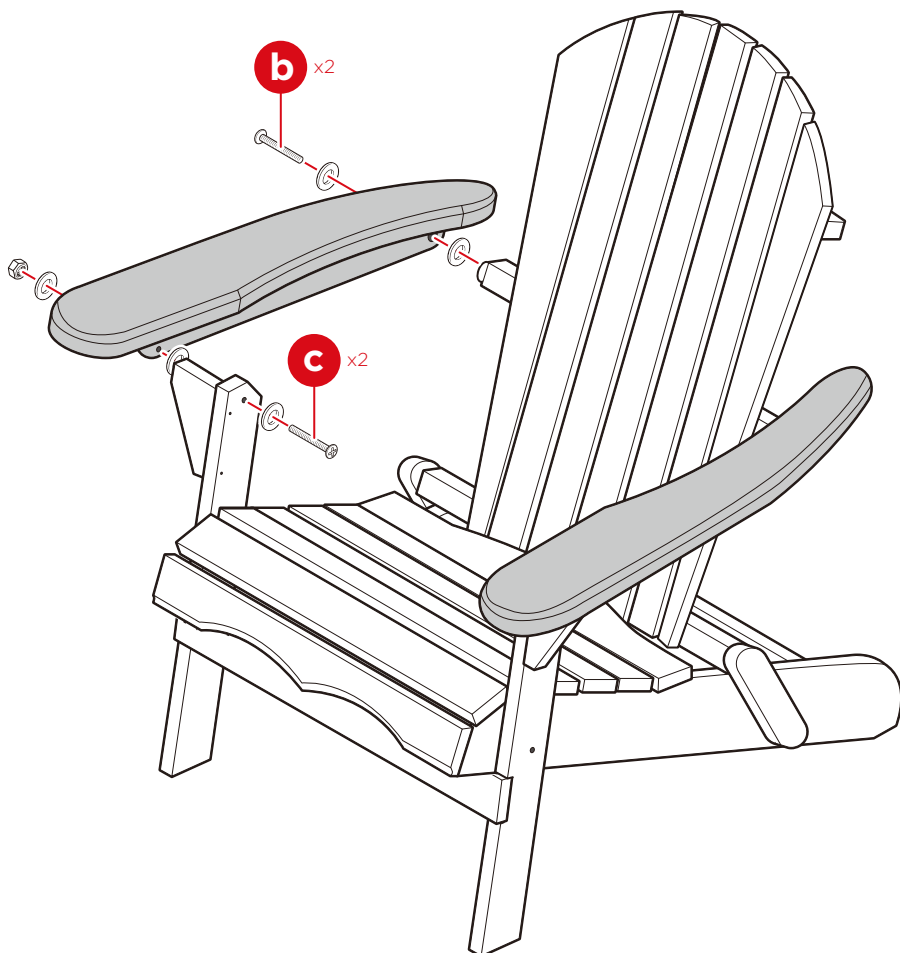



HELP CENTER



Question about your product? We're here to help. Visit us at:

help.bestchoiceproducts.com



Chat Support



Product Inquiry



Orders FAQ



Product Assembly



Returns & Refunds

PRODUCT WARRANTY INFORMATION

All items can be returned for any reason within 60 days of the receipt and will receive a full refund as long as the item is returned in its original product packaging and all accessories from its original shipment are included. All returned items will receive a full refund back to the original payment method. All returned items will not be charged a re-stocking fee.

All returned items require an RA (Return Authorization) number, which can only be provided by a Best Choice Products Customer Service Representative when the return request is submitted. Items received without an RA may not be accepted or may increase your return processing time. Once an item has been received by Best Choice Products, refunds or replacements will be processed within 5 business days.

All returns must be shipped back to the Best Choice Products Return Center at the customer's expense. If the reason for return is a result of an error by Best Choice Products then Best Choice Products will provide a pre-paid shipping label via email. Boxes for return shipping will not be provided by Best Choice Products, and is the customer's responsibility to either use the original shipping boxes or purchase new boxes.

Pictures may be required for some returns to ensure an item is not damaged prior to its return. Items returned are not considered undamaged until they are received by Best Choice Products and verified as such. All damages to items are the customer's responsibility until the item has been received by and acknowledge by Best Choice Products as undamaged.



WARNING

Manufacturer and seller expressly disclaim any and all liability for personal injury, property damage or loss, whether direct, indirect, or incidental, resulting from the incorrect attachment, improper use, inadequate maintenance, or neglect of this product.