

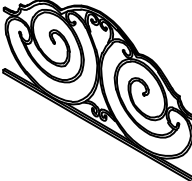











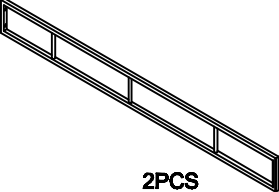
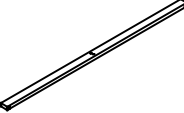



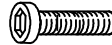

ASSEMBLY INSTRUCTION

METAL POSTER BED

A Headboard Panel  1PC	B Headboard Poster  2PCS	C Footboard Panel  1PC	D Footboard Poster  2PCS	E Side Rail  2PCS	
F Slat  3PCS	G Support Leg  3PCS	H Finial  4PCS	I Mounting Plate  2PCS	J Bolt $\text{Ø}5/16 \times 1-3/4$ "  8PCS	K Lock Washer $\text{Ø}5/16$ "  8PCS
L Flat Washer $\text{Ø}5/16 \times \text{Ø}3/4$ "  8PCS	M Plastic Washer $\text{Ø}5/16$ "  12PCS	N Bolt $\text{Ø}1/4 \times 5/8$ "  8PCS	O Lock Washer $\text{Ø}1/4$ "  16PCS	P Flat Washer $\text{Ø}1/4$ "  16PCS	Q Sunk Bolt $\text{Ø}1/4 \times 1-3/4$ "  6PCS
R Bolt $\text{Ø}1/4 \times 1-1/4$ "  4PCS	S Nut $\text{Ø}1/4$ "  4PCS	T Allen Wrench 4mm  1PC	U Allen Wrench 5mm  1PC	W Open Wrench $\text{Ø}1/4$ "  1PC	

This page lists all the contents included in the box. Please take the time to identify the hardware as well as the individual components to this product. As you unpack and prepare for assembly, place the contents on a carpeted or padded area to protect them from damage.

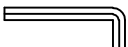
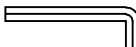
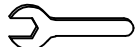
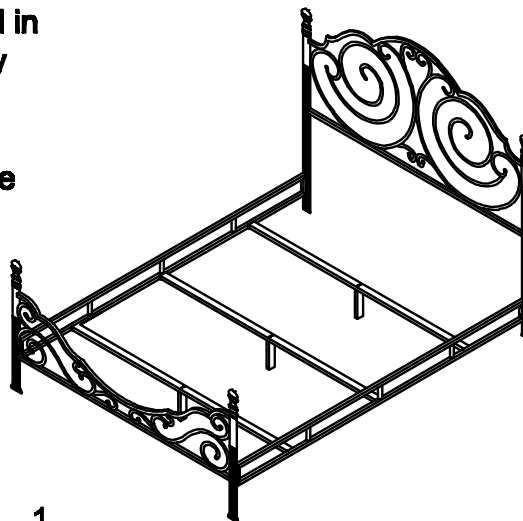

METAL POSTER BED

1 Use the Bolts(N) with the Locker Washer(O) and Flat Washer(P) to tighten the Headboard Panels(A) with the Headboard Posts(B) by 4mm Allen Wrench(T). Directly screw the Finials(H) onto the Headboard Posts(B).

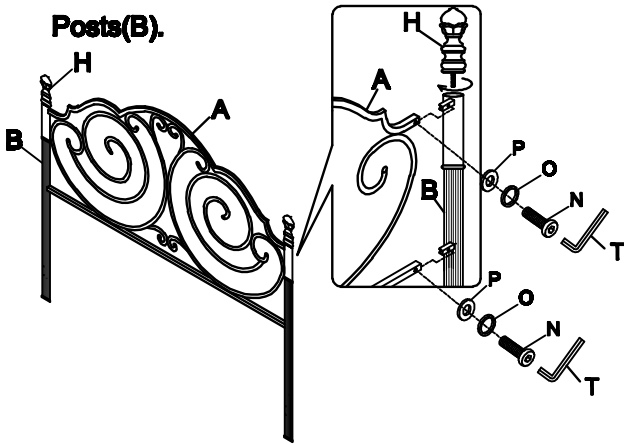

2 Use the Bolts(N) with the Locker Washer(O) and Flat Washer(P) to tighten the Footboard Panels(C) with the Footboard Posts(D) by 4mm Allen Wrench(T). Directly screw the Finials(H) onto the Footboard Posts(D).

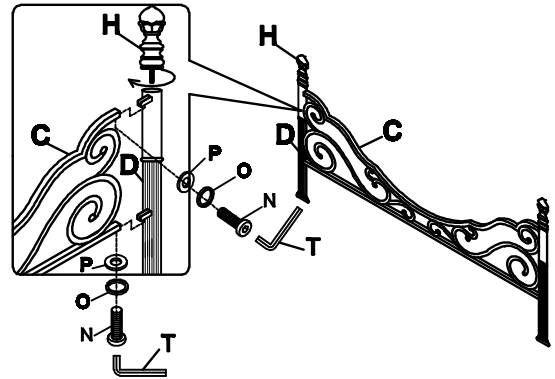

3 Use Bolt(J) with Lock Washer(K), Flat Washer(L), and Plastic Washer(M) to connect Side Rails onto Headboard and Footboard Panels, by 5mm Allen Wrench(U).

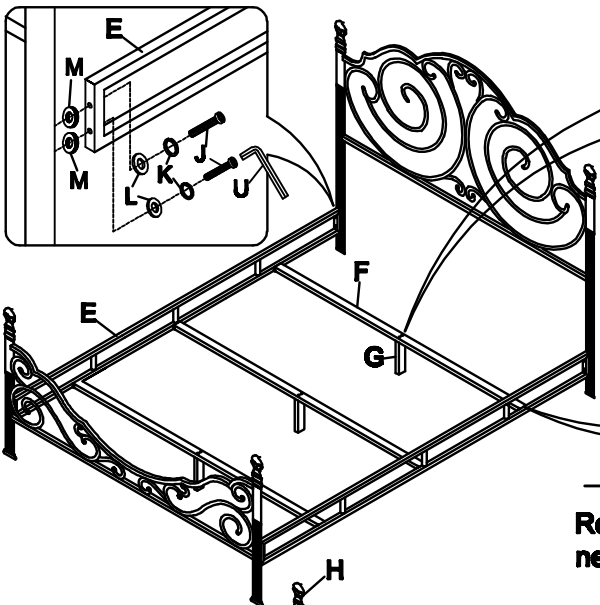

4 Use Sunk Bolt(Q) to tighten the Support Legs(G) onto Slats(F), by 4mm Allen Wrench(T).

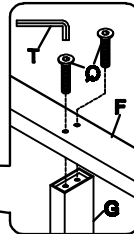

5 Make sure the Slats(F) are properly tenoned onto Side Rails(E).

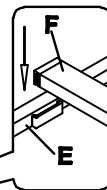

Remark: All the Head Board should add Mounting Plate(s) if you need to match standard side rail frame(s).

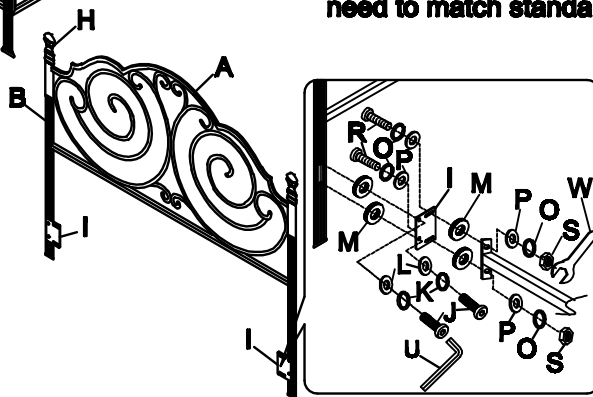

Steps:

Use Bolt(J) with Lock Washer(K), Flat Washer(L), and Plastic Washer(M) to connect Mounting Plate(I) onto Headboard Panels, by 5mm Allen Wrench(U). Then, use the Bolt(R) with the Locker Washer(O), Flat Washer(P), Plastic Washer(M), and Flat Washer(P), Locker Washer(O), Nut(S) to tighten the Side Rail with the Mounting Plate(I) by Open Wrench(W)

Cleaning & Care : Treat surface with care. Surface is resistant to scratches but is not scratch resistant. Clean surfaces with a dry or damp soft cloth. Do not use abrasive cleaners. Hardware may loosen over time. Periodically check that all connections are tight.