

Product Specifications

12.2 Gallon Screw Top ST3 Pail with Cover

Note: *UN Solids rated to Y59.0/S

Multiple Uses

Dry Products

Product Codes

Pail: **9900 Series**

Description: 12.2 Gallon Screw Top Pail

Cover: **8900 Series**

Description: 12.2 Gallon Screw Top Cover

Features

Gauge: 100 mil

Nominal capacity: 12.2 USG / 46.2 L

Stack performance: 350 lbs.*

Tare weights: Body: 5.84 lbs. / 2,650 gr.

Cover: 1.45 lbs. / 660 gr.

Note: *Ratings will be reduced with uneven load distribution.

Specifications with Cover

Dimensions: 16 1/8" D. X 21 1/4" H

Maximum capacity: 12.3 USG / 46.5 L

Tare weight: 7.29 lbs. / 3.3 kgs.

Colors

Standard: White, Black and Natural

Custom: Available at manufacturer's discretion

Decorating Options

Four color offset printing

Print area: 36"W X 11 3/4"H

Sleeve or pressure sensitive labeling

Shipping Data

Qty. per pallet/carton:

Bodies

108*

Covers

594*

Gross Weight (lbs./kgs.)**:

594/269.4

784/355.6

Length (in./cm.):

47/119.4

47/119.4

Width (in./cm.):

47/119.4

47/119.4

Height (in./cm.):

93/236.2

87/220.9

Approximate truckload quantity of 2,592 pails and covers***

Filled Containers

36 (12 per layer/3 layers high)

Pallet height: 63 5/16"

Notes:

*Quantity can vary based on customer request

**Weight does not include pallet/packaging

***Based on 53' trailer and full pallet quantities

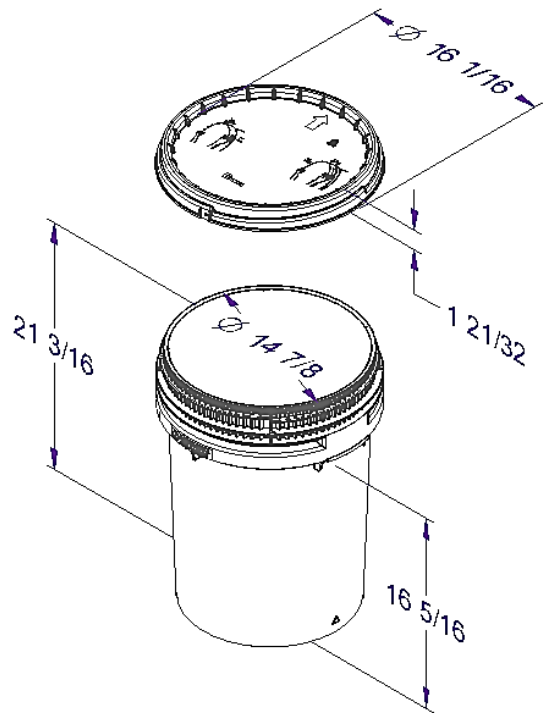

Materials

FDA approved materials

Resin: Body: High-Density Polyethylene (HDPE)

Cover: High-Density Polyethylene (HDPE)

MSDS Sheets available upon request

Carrying Handle – Molded in grip

DISTRIBUTED BY:



REF NO.:

DWG30558

DESCRIPTION:

HDPE Screw Top Cover for 12.2 Gallon Pails (No Gasket)

DISCLAIMER

THIS INFORMATION IS PROVIDED AS A GENERAL GUIDE, INCLUDING DIMENSIONS. IT IS THE CUSTOMER'S RESPONSIBILITIES TO SELECT THE PROPER CONTAINER FOR PRODUCT AND APPLICATION COMPATIBILITY.