

# BLACK DIAMOND®

Project Name: \_\_\_\_\_

Location: \_\_\_\_\_

Item #: \_\_\_\_\_

Qty: \_\_\_\_\_

## Black Diamond Chest Freezer, Single Solid Door, 5.4 Cu. Ft., in White

### BDCF-5



Black Diamond's Chest Freezer offers exceptional frozen storage for commercial use, ideal for restaurants, cafes, and grocery stores. Featuring a solid steel door, this white chest freezer is built to last with a powder-coated exterior and embossed aluminum interior. It offers a 5.4 cubic feet capacity, perfect for storing bulk food. The freezer maintains temperatures between -4° and 3.2°F. The mechanical control and R600a refrigerant ensure efficient performance, while easy-to-clean surfaces enhance usability.

### FEATURES AND CONSTRUCTION

- Offers a generous 5.4 Cu. Ft. capacity for ample frozen storage
- Features a 1/8 horsepower side-mounted compressor for efficient cooling
- Constructed with a white powder-coated steel exterior and embossed aluminum interior
- Maintains a temperature range of -4° to 3.2°F for optimal food preservation
- Utilizes eco-friendly R600a refrigerant for efficient cooling performance
- Operates on 115V with a NEMA-5-15P plug for convenient power access
- Includes a wire coated basket for organized storage
- Built-in casters provide easy mobility for cleaning and repositioning
- Hinged lid opens 90° for easy access to stored items
- Mechanical controls offer user-friendly temperature adjustments

### ELECTRIC

115V / Hz / 1Ph

Cord Length (Inches): 70"

Plug Type: NEMA 5-15P

Cord set included

NEMA 5-15P



### 3RD PARTY APPROVALS



### WARRANTY (USA / CANADA)

One (1) Year Limited Warranty on Parts and Labor, One (1) Year Warranty on Compressor and Evaporator

Contact us for details at 1.877.368.2797



### STORAGE CAPACITY

- Cubic Feet: 5.4 Cu. Ft.

### TEMPERATURE

- Holding Temperature (Fahrenheit): -4° - 3.2°

These models are designed to operate in an environment where temperature and humidity do not exceed 75°F (24°C) and 55% relative humidity



# Black Diamond Chest Freezer, Single Solid Door, 5.4 Cu. Ft.

BDCF-5

FRONT

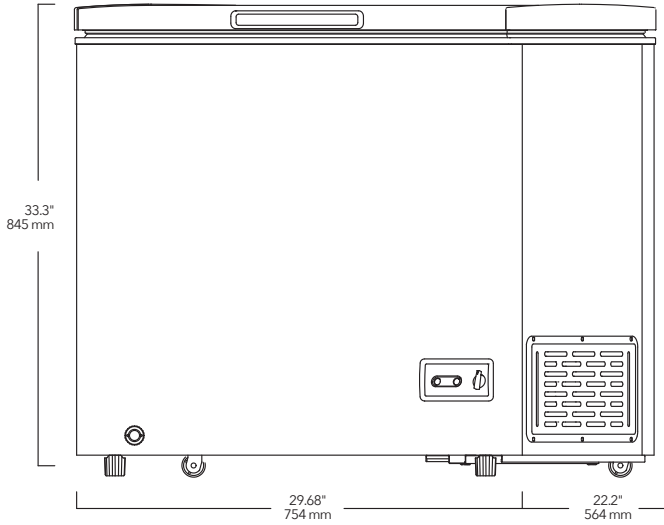

SIDE

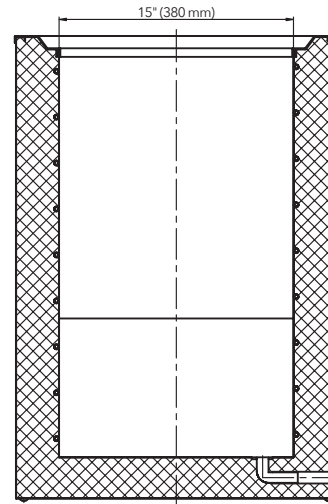

OPEN

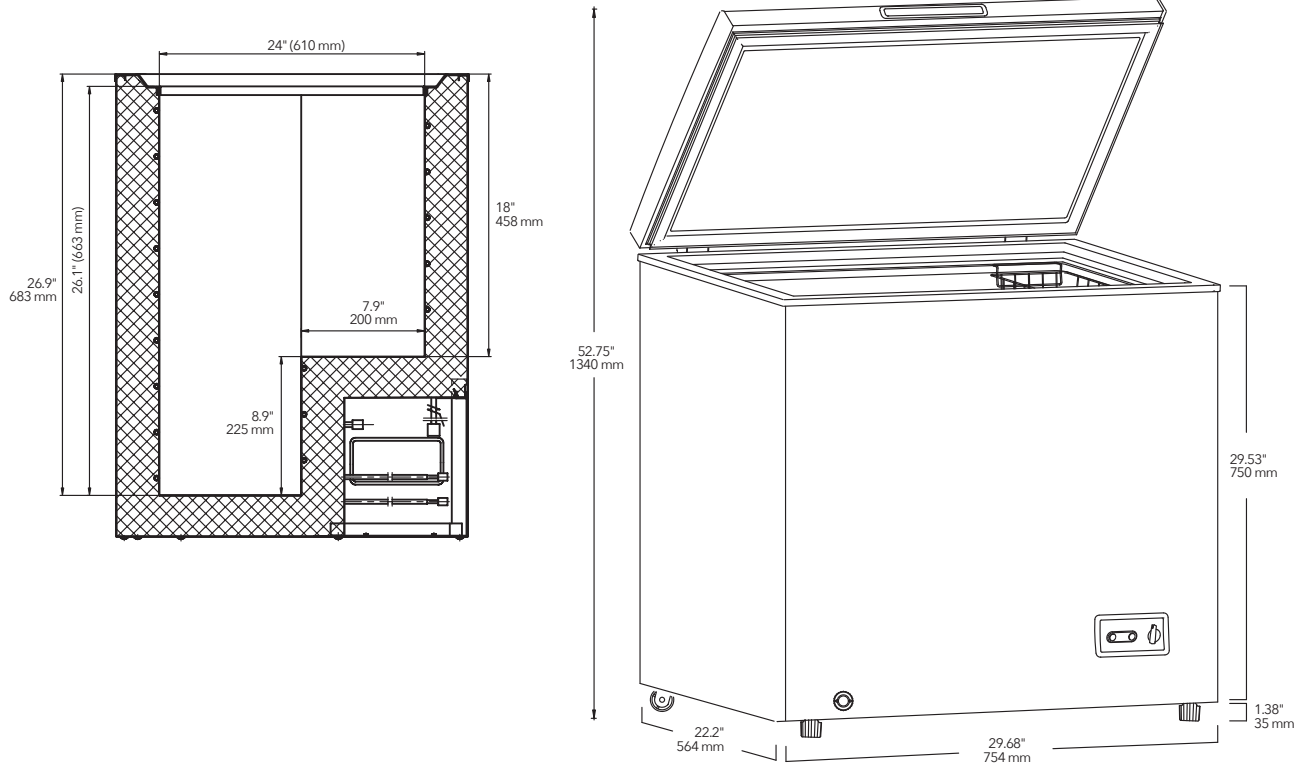

## Chest

| Doors | Baskets Included | Casters | Refrigerant      | Amps | HP  | Wattage | Assembled Dimensions (in) | Item Weight (lbs) | Shipping Weight (lbs) |
|-------|------------------|---------|------------------|------|-----|---------|---------------------------|-------------------|-----------------------|
| 1     | 1                | 2       | R600a<br>1.41 oz | 1.2A | 1/8 | 115W    | 22.20" x 29.68" x 33.33"  | 68.3              | 75.0                  |

Due to periodic changes in designs, methods, procedures, policies and regulations, the specifications contained in this document are subject to change without notice. While we exercise good faith efforts to provide information that is accurate, we are not responsible for errors or omissions in information provided or conclusions reached as a result of using the specifications. By using the information provided, the user assumes all risks in connection with such use.