

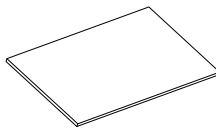

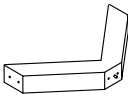
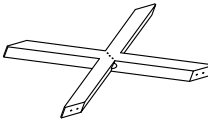
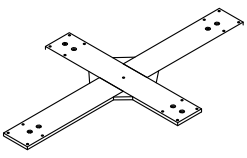
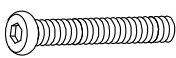
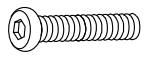

# ASSEMBLY INSTRUCTIONS

## 72" RECTANGULAR DINING TABLE

<b>A</b> Table Top	<b>B</b> Side Leg	<b>C</b> Center Leg	<b>D</b> Mounting Rail
			
1 PC	2 PCS	1 PC	1 PC
<b>E</b> Long Bolt 5/16" x 2"	<b>F</b> Short Bolt 5/16" x 1-1/2"	<b>G</b> Lock Washer 5/16"	<b>H</b> Flat Washer Ø5/16" x 3/4"
			
4 PCS	17 PCS	21 PCS	21 PCS
<b>I</b> Allen Key M4			
			
1 PC			

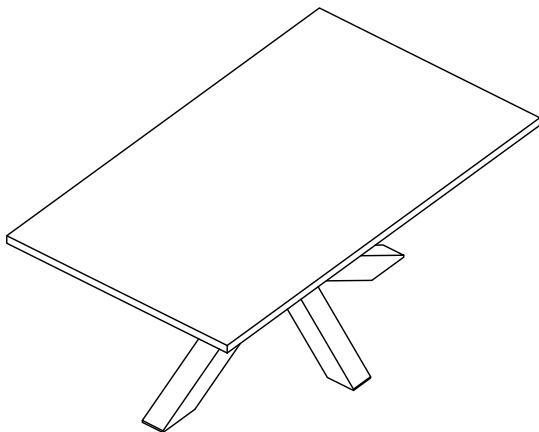

This page lists all the contents included in the box. Please take the time to identify the hardware as well as the individual components to this product. As you unpack and prepare for assembly, place the contents on a carpeted or padded area to protect them from damage.

- 1** Place one Side Leg (B) and the Center Leg (C) upside down, then attach them using Long Bolt (E), Lock Washer (G) and Flat Washer (H) with the Allen Key (I).

**Note: At this step, only connect the bottom hole of the Side Leg (B) to the bottom hole of the Center Leg (C).**

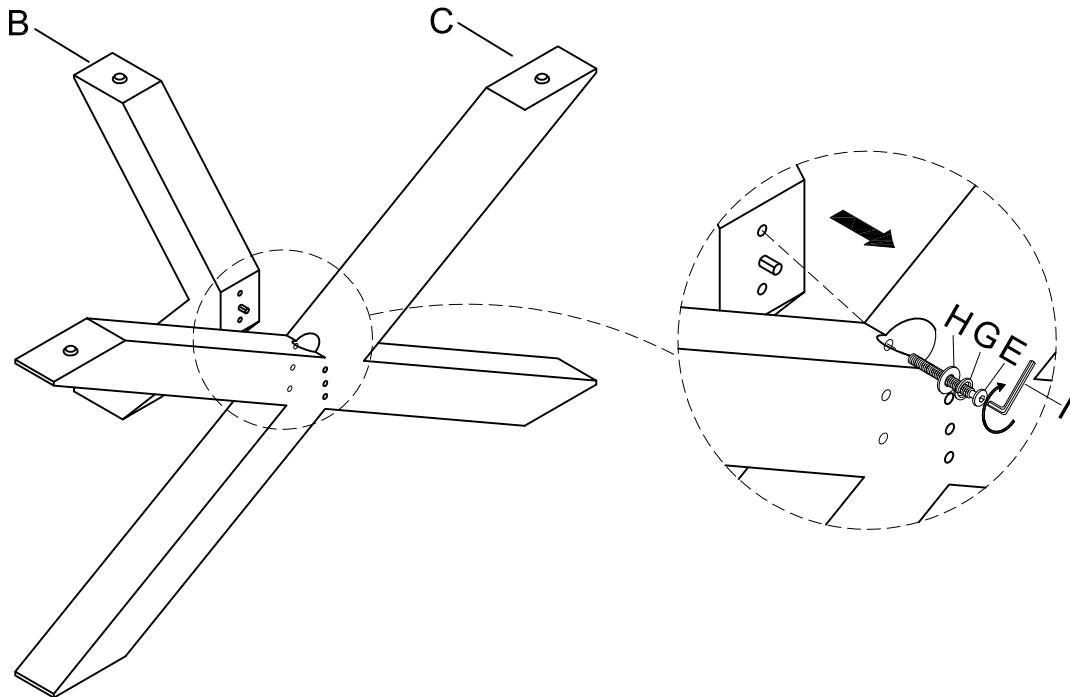

- 2** Place the other one Side Leg (B) upside down and attach it to the Center Leg (C) using Long Bolt (E), Lock Washer (G) and Flat Washer (H) with the Allen Key (I).

**Note: At this step, only connect the bottom hole of the Side Leg (B) to the bottom hole of the Center Leg (C).**

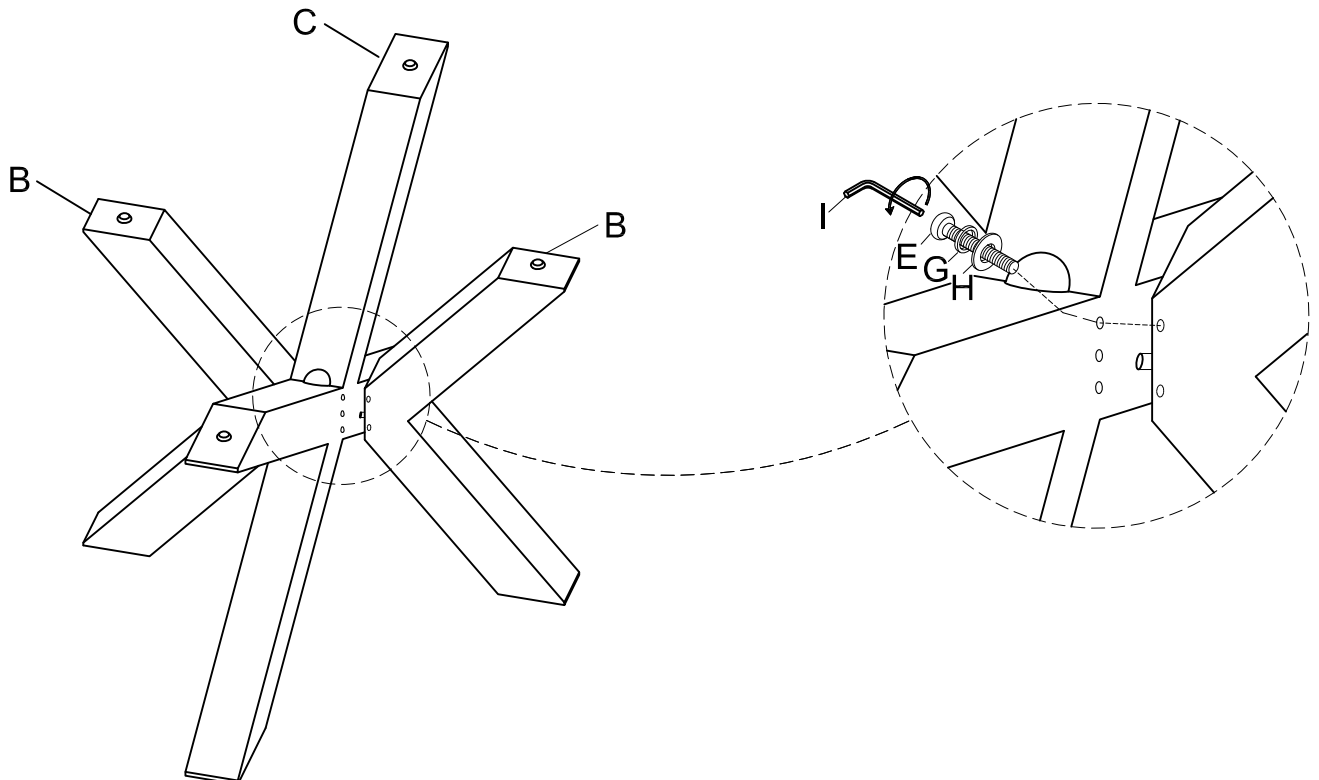

- 3** With the assistance of your adult partners, carefully turn the assembled base upright. Attach the Side Leg (B) to the Center Leg (C) by connecting the upper holes of the Side Leg (B) to the corresponding upper holes of the Center Leg (C) using Long Bolt (E), Lock Washer (G) and Flat Washer (H) with the Allen Key (I).

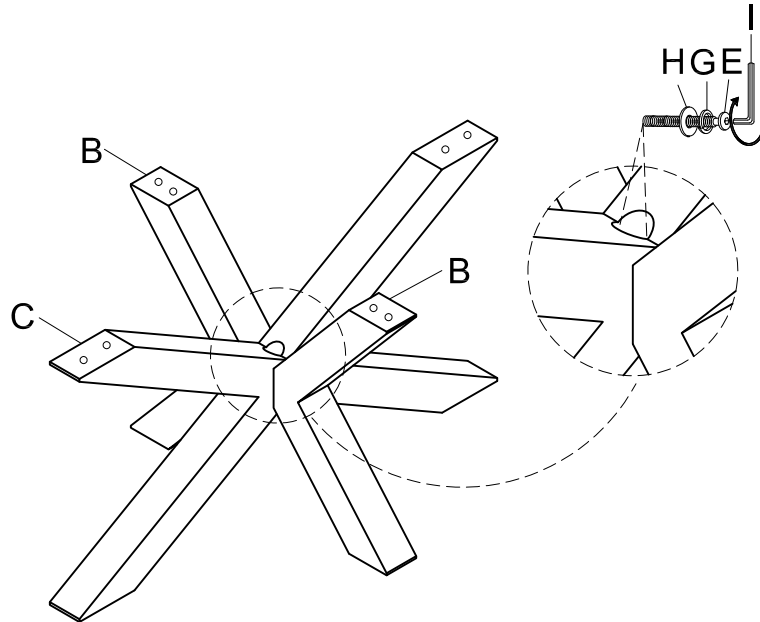

- 4** Remove the Mounting Rail (D), Short Bolt (F), Lock Washer (G) and Flat Washer (H) from the bottom of the Table Top (A) with the Allen Key (I).

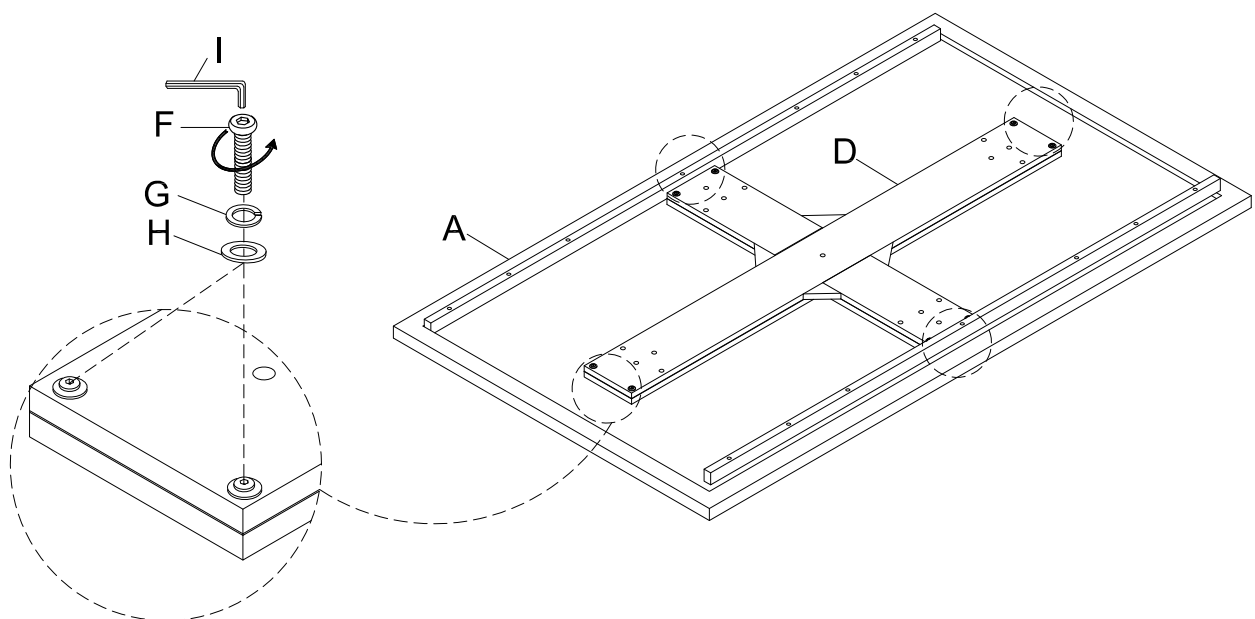

- 5** Attach the Mounting Rail (D) to the top of the Side & Center Leg (B & C) using Short Bolt (F), Lock Washer (G) and Flat Washer (H) with the Allen Key (I).

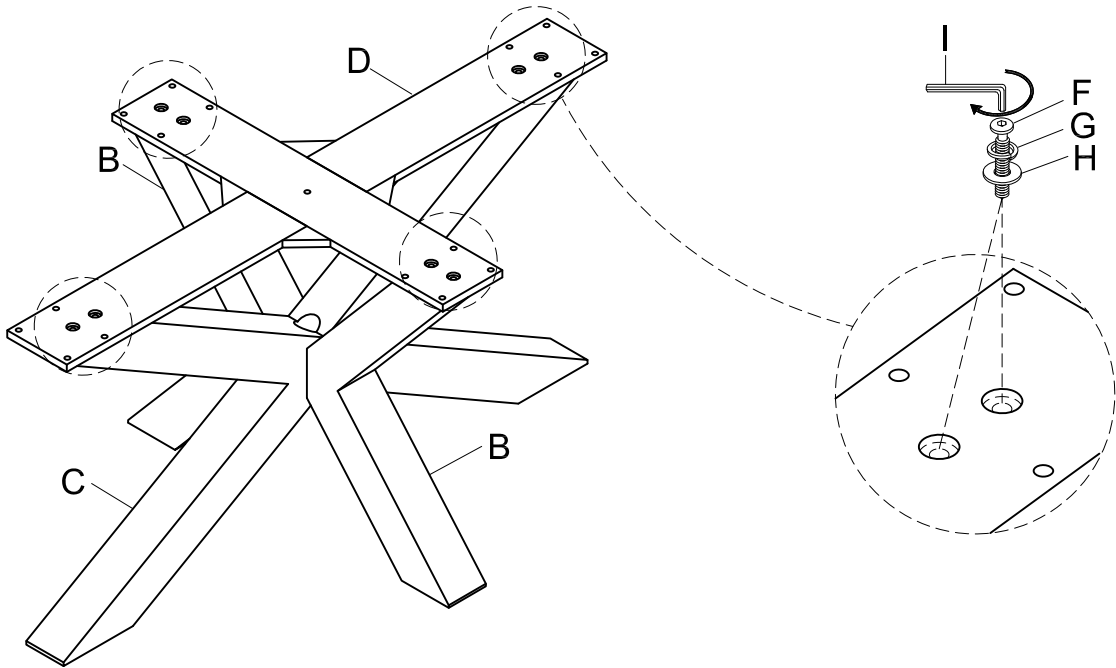

- 6** Attach the assembled base to the bottom of the Table Top (A) using Short Bolt (F), Lock Washer (G) and Flat Washer (H) with the Allen Key (I).

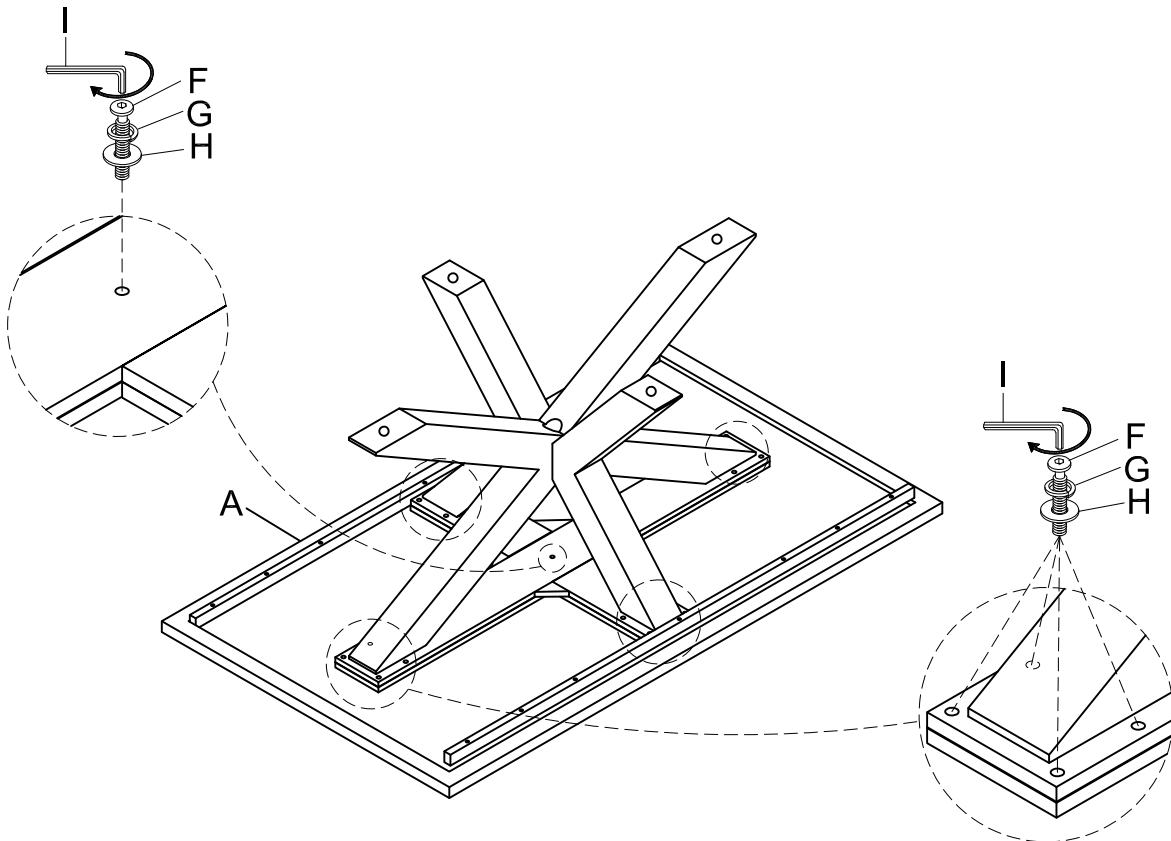

- 
- 7** With the assistance of your adult partners, carefully stand the table upright. If the table wobbles slightly, adjust the pre-installed levelers on the bottom of the legs until the table is stabilized.

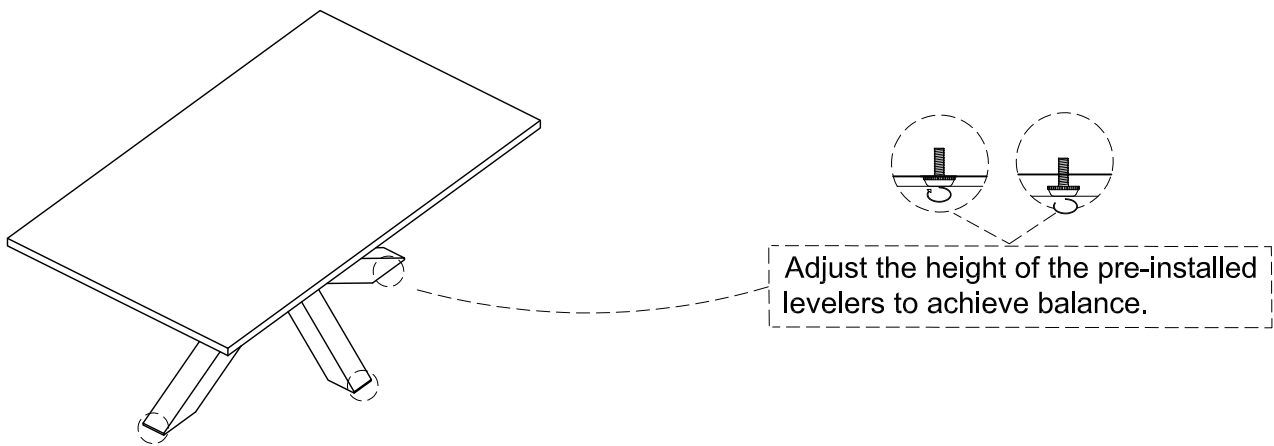

---

#### Cleaning & Care

Treat surfaces with care. Surfaces are resistant to scratches but are not scratch resistant. Clean surfaces with a dry or damp soft cloth. Do not use abrasive cleaners. Hardware may loosen over time. Periodically check that all connections are tight.