

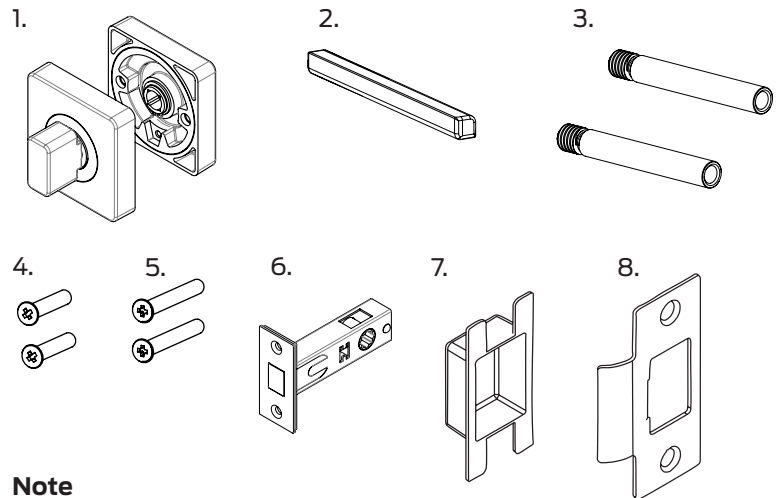

# Verta Privacy Turn Installation Instructions

## Contents

1. 1 x Privacy Turn Set
2. 1 x Spindle
3. 2 x Studs
4. 2 x Fixing Screws (M4 x 25mm)
5. 2 x Fixing Screws (M4 x 35mm)
6. 1 x Bolt
7. 1 x Dust Box
8. 1 x Strike Plate



## Tools Required

- Tape measure
- Soft pencil
- Level
- 6.5mm, 8mm & 24mm drill bits
- Power drill
- Philips screwdriver

## Note

Check door thickness first

- For doors 35-40mm thick, use 20mm M4 screws (x2)
- For doors 40-45mm thick, use 30mm M4 screws (x2)

## Step 1: Door Preparation

If door is predrilled, go to step 2, otherwise follow the steps below

- 1.1 With a soft pencil, mark holes as per template
- 1.2 Check alignment using a level
- 1.3 Drill holes
- 1.4 Mark the centre for the latch hole and drill  $\varnothing 24$  mm x 85 mm deep

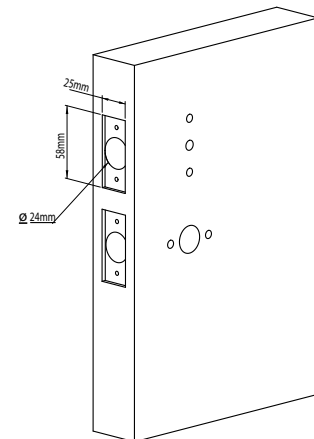

## Step 2. Install Bolt

- 2.1 Insert bolt into hole. Trace around the face plate
- 2.2 Chisel until faceplate fits flush with door face
- 2.3 Drill 2 pilot holes for latch fixing screws
- 2.4 Fasten with screws

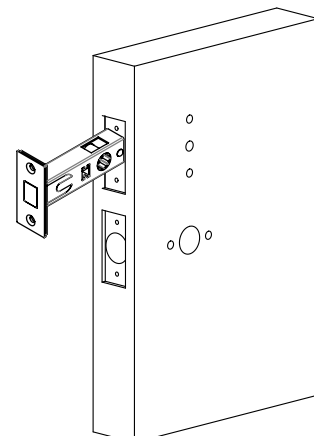

### Step 3: Furniture Installation

- 3.1 Screw studs onto rose as shown and cut spindle to length and insert into furniture
- 3.2 Align studs with drilled holes and mount external furniture to door. Secure the internal turn with M4 screws and install rose caps so they are flush with door surface

3.1

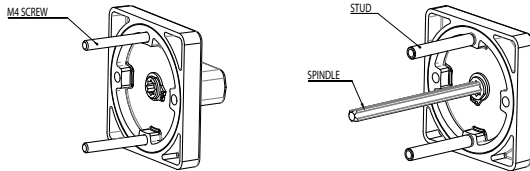

3.2

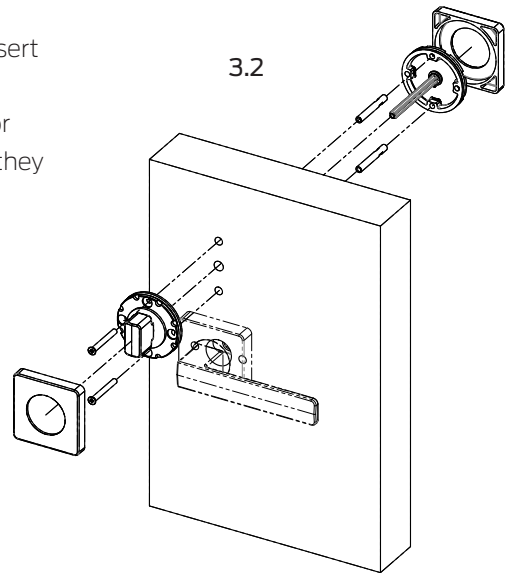

### Step 4: Prepare Jamb & Install Strike

- 4.1 Mark vertical and horizontal centreline on jamb, exactly opposite centre of latch
- 4.2 Use strike plate as pattern for cut-out. Chisel until strike plate fits flush with jamb face
- 4.3 Use strike plate as pattern, chisel or drill 15mm deep for bolt hole allowing space behind strike plate for the dust box
- 4.4 Insert dust box, drill 2 pilot holes and screw strike plate in place

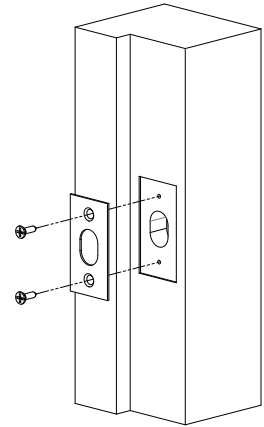

### Face Fixing Instructions (for mortice lock applications)

- Mark spindle hole and pilot holes as per template
- Check alignment using a level and drill holes
- Cut spindle to length and insert into furniture
- Secure furniture with G6 screws (not provided)
- Install rose caps so they are flush with door surface

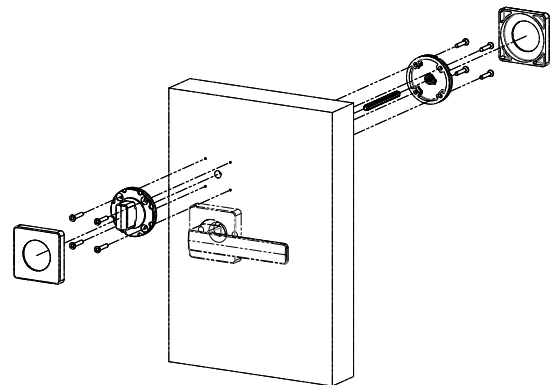

#### Allegion New Zealand

Freephone 0800 477 869  
Email [nzinfo@allegion.com](mailto:nzinfo@allegion.com)  
[www.allegion.co.nz](http://www.allegion.co.nz)



For more information visit  
[schlage.co.nz/verta](http://schlage.co.nz/verta)

PDSC0055

© 2024 Allegion

