

section A-A
scale: 1:2

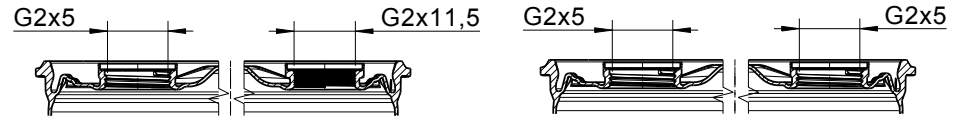

Gallon marking

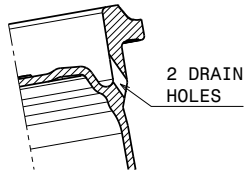
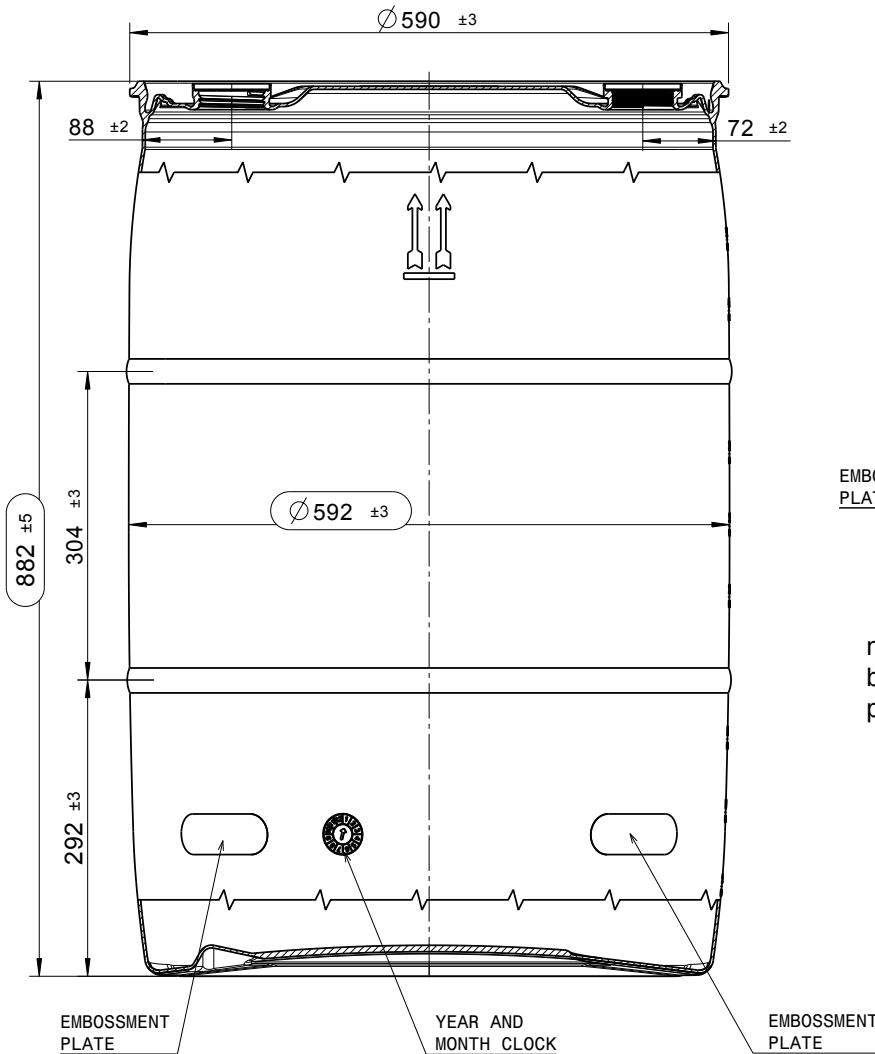

TOP
scale: 1:10

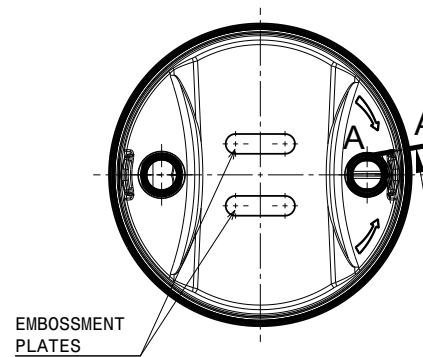

BOTTOM
scale: 1:10

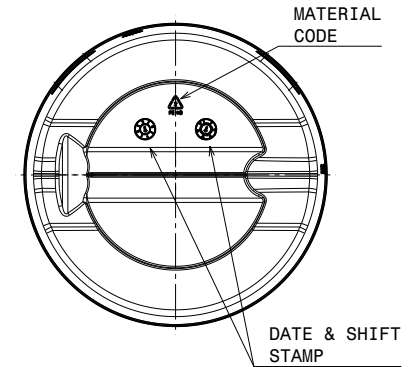

nominal capacity: 55gal. (208,2l)
brimful capacity: min. 57,2gal. (216,5l)
pour out < 100ml

DISCLAIMER

THIS INFORMATION IS PROVIDED AS A GENERAL GUIDE, INCLUDING DIMENSIONS. IT IS THE CUSTOMER'S RESPONSIBILITIES TO SELECT THE PROPER CONTAINER FOR PRODUCT AND APPLICATION COMPATIBILITY.

DISTRIBUTED BY:



REF NO.:

DWG30475

DESCRIPTION:

55 Gallon Black HDPE Tight Head Drum

Technical dates:

nominal volume : 55.0 gal. (208.2 litre)
overflow volume min. : 57.2 gal. (216.5 litre)

outer height : 34.80 +/- 0.20" (882 +/-5 mm)
outer diameter : 23.30 +/- 0.12" (592 +/-3 mm)
bung design : 2" NPS / 2" Buttress

weight total :19.30 +/-0.44 lbs (8.8 +/-0.2 kg)

Material:

drum body : HDPE
color : Black outside / Natural inside
bung plug : Polypropylene
color : natural
gasket : EPDM / white

Description:

body:
one -piece -blow-molded tight head drum, with two blow molded bungs in the top
top and blow molded -ring.

drum openings :
a) 2" NPS threaded opening
b) solid plug with male thread 2" NPS
c) 2" Buttress threaded opening
d) solid plug with male thread 2" Buttress

UN-marking:

- UN 1H1 / Y1.9 / 150/ ...*/ USA etc...
- UN 1H1 / Y1.4 / 150/ ...*/ USA etc...with vent
* year of production ...

DISCLAIMER
THIS INFORMATION IS PROVIDED AS A GENERAL GUIDE, INCLUDING DIMENSIONS. IT IS THE CUSTOMER'S RESPONSIBILITIES TO SELECT THE PROPER CONTAINER FOR PRODUCT AND APPLICATION COMPATIBILITY.

DISTRIBUTED BY:  Pipeline Packaging

REF NO.:
DWG30475

DESCRIPTION:
55 Gallon Black HDPE Tight Head Drum