

# BLACK DIAMOND®

Project Name: \_\_\_\_\_

Location: \_\_\_\_\_

Item #: \_\_\_\_\_

Qty: \_\_\_\_\_

## Black Diamond Refrigerated Pizza Prep Table, Two Solid Doors, in Stainless Steel

### GRPZ-2D



Elevate your commercial kitchen's efficiency with the Black Diamond Refrigerated Pizza Prep Table, featuring a 19.3 Cu. Ft. storage capacity for ample ingredient organization. Crafted with a durable stainless steel exterior, this prep table ensures longevity and easy maintenance. The unit utilizes eco-friendly R290 refrigerant, operates with an automatic defrost system, and maintains a safe temperature range of 33° to 40°F for optimal food preservation. User-friendly controls, adjustable shelves, and smooth-rolling casters streamline setup and repositioning. Backed by a two-year parts and labor warranty and five-year compressor warranty, it's a reliable solution for high-volume kitchens.

### FEATURES AND CONSTRUCTION

- Offers 19.3 Cu. Ft. of refrigerated storage capacity for efficient ingredient organization
- Equipped with a 0.75 HP side-mount compressor for energy-efficient, reliable performance
- Features a durable stainless steel exterior and painted aluminum interior for lasting performance and easy cleaning
- Maintains a temperature range of 33°F to 40°F for optimal freshness and food safety
- Utilizes an environmentally friendly R290 refrigerant
- Incorporates two solid stainless steel doors with self-closing mechanism for secure and efficient operation
- Includes two adjustable, plastic-coated steel shelves for flexible ingredient storage
- Fitted with four 4-inch casters, including two locking casters, for easy mobility and secure placement
- Polyethylene cutting board included for convenient prep work

### ELECTRIC

115VV / 60Hz / 1Ph

Cord Length (Inches): 98.40"

Plug Type: NEMA 5-15P

Cord set included

NEMA 5-15P



### 3RD PARTY APPROVALS



### WARRANTY (USA / CANADA)

Two (2) Year Limited Warranty on Parts and Labor, Five (5) Year Warranty on Compressor and Evaporator

Contact us for details at 1.877.368.2797



### STORAGE CAPACITY

- Cubic Feet: 19.3 Cu. Ft.

### TEMPERATURE

- Holding Temperature (Fahrenheit): 33° - 40°

These models are designed to operate in an environment where temperature and humidity do not exceed 75°F (24°C) and 55% relative humidity



# Black Diamond Refrigerated Pizza Prep Table

GRPZ-2D

FRONT

SIDE

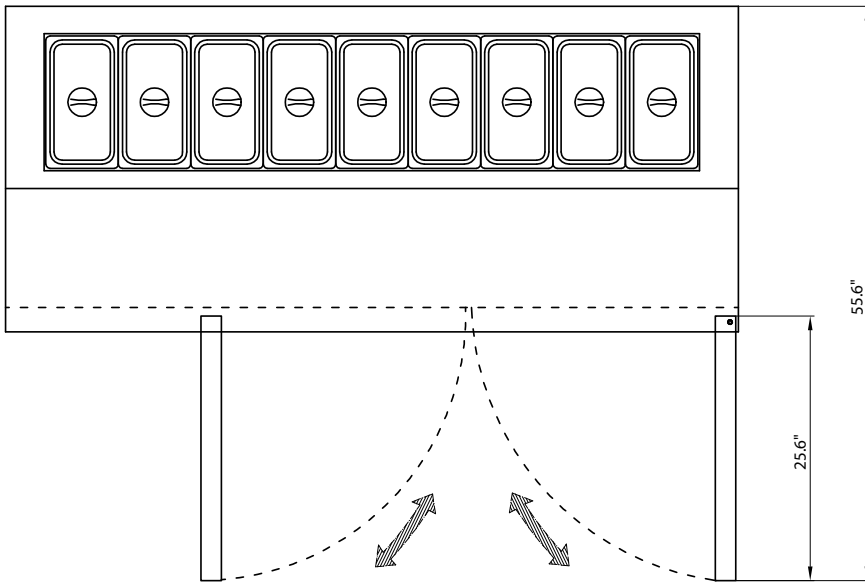
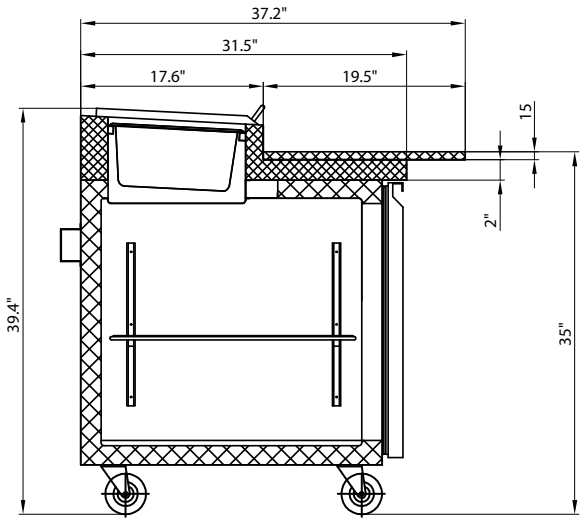
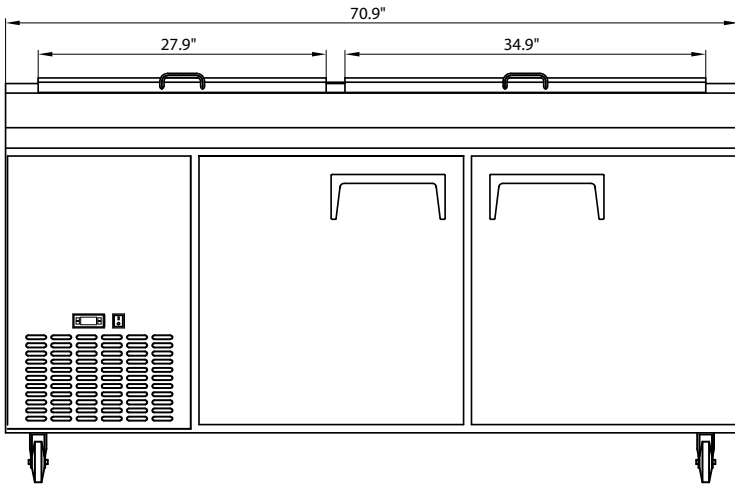

TOP

## Prep Table

Doors	Shelves	Amps	HP	Refrigerant	Capacity	Assembled Dimensions (in)	Item Weight (lbs)	Shipping Weight (lbs)
2	2	4.8A	1/5	R290 3.883	19.3 Cu. Ft.	70.90" x 31.50" x 39.40"	341.0	475.0

Due to periodic changes in designs, methods, procedures, policies and regulations, the specifications contained in this document are subject to change without notice. While we exercise good faith efforts to provide information that is accurate, we are not responsible for errors or omissions in information provided or conclusions reached as a result of using the specifications. By using the information provided, the user assumes all risks in connection with such use.