

**DESCRIPTION**

The H37T-401AL is specifically designed for use as a heat lamp with up to a 250W R40 IR lamp. Brushed aluminum trim is corrosion resistant.

<b>Catalog #</b>		<b>Type</b>
<b>Project</b>		
<b>Comments</b>		<b>Date</b>
<b>Prepared by</b>		

**APPLICATION**

The H37T is a suited for use in non-insulated ceilings in residential and commercial applications. If ceiling insulation is present, it must be kept 3" from the fixtures on all sides.

**DESIGN FEATURES**

**A...Housing**

Die-stamped 20 gauge CRS with white powder coat finish.

**B...Socket Plate**

Rigid socket plate adjusts and locks without tools.

**C...Plaster Frame**

Housing adjusts in plaster frame 1 3/8" to accommodate different ceiling thicknesses.

**DESIGN FEATURES**

**D...Junction Box**

Junction box features include:

- UL listed for through branch circuit wiring
- Positioned to accommodate straight conduit runs
- Seven 1/2" trade size conduit knockouts with true pry-out slots

**E...Bar Hangers**

Two-piece bar hangers span up to 24" joists. Plaster

**F...Socket**

Porcelain socket with nickel plated brass screw shell.

**G...Thermal Protector**

Self resetting thermal protector deactivates fixture if overheating occurs due to improper lamping or misapplied insulation.

**Labels**

- UL Listed for Damp Location
- UL listed for Feed Through
- CSA Certified
- IP Rated



**H37T-401AL**

6"

**Non-Insulated Ceiling Recessed Housing**

**HEAT LAMP**

**FOR USE IN NON-INSULATED CEILINGS**

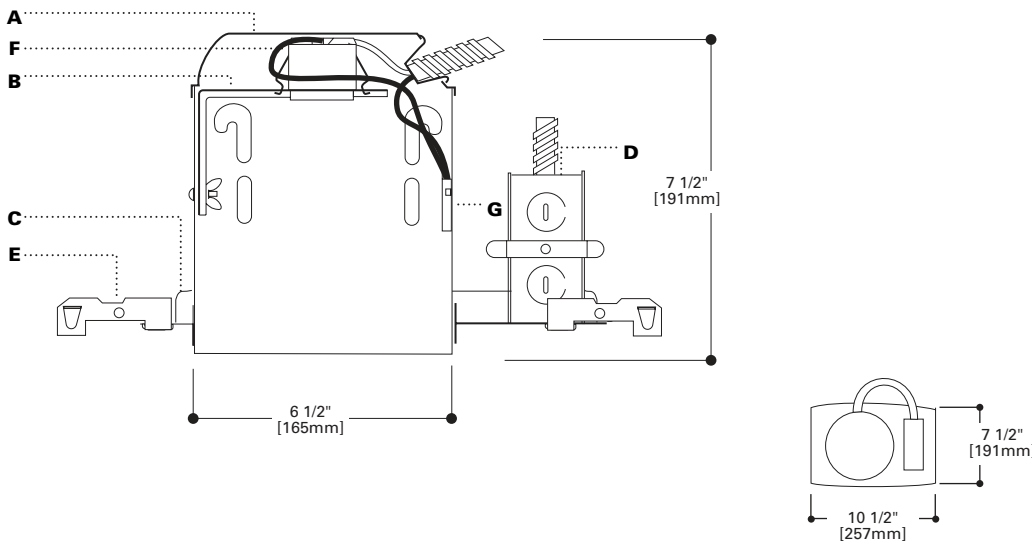

**ORDERING INFORMATION**

SAMPLE NUMBER: H37T-401AL

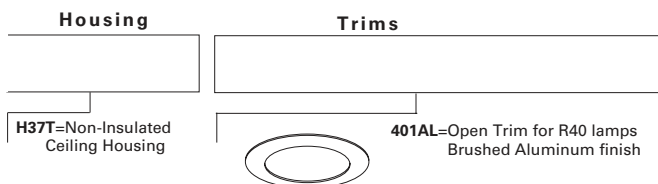

ADV071023  
6/07

Note: Specifications and Dimensions subject to change without notice.

Visit our web site at [www.cooperlighting.com](http://www.cooperlighting.com)

