

# Product Specifications

## Tamper-Evident Round EZ Cover® (LTGZ) w/FS10 Spout

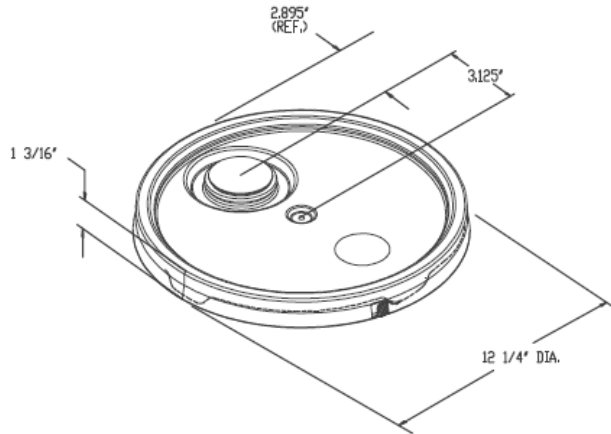

LTGZ-LIDWITH FS-10 INSERT

### Features

- Exclusive four-tab EZ Cover® design
- EZ to open and reseal
- Heavy duty cover performance
- EPDM Gasket seal for liquid applications – additional gasket options available
- Multiple fitment options available

### Used with 12-3/8" Diameter Bodies

<u>Models</u>	<u>Nominal capacity</u>
C127	3.2-gallon
R038/R039	3.5-gallon
R358	3.5-gallon
R047/R049	4.25-gallon
R458	4.5-gallon
R057/R058/R059	5.0-gallon
C538/C539	5.3-gallon
C549	5.3-gallon
R068/R069	6.0-gallon

### Product Weight

LTGZ: .58 lbs. / .26 kgs.

### Shipping Data

Qty. per pallet/carton:	1,152 (24 boxes of 48)
Length (in./cm.):	52/132.1
Width (in./cm.):	40/101.6
Height (in./cm.):	101.5/257.8

### Materials

- Resin: Prime High Density Polyethylene (HDPE)
- FDA and USDA approved materials
- MSDS Sheets available upon request

DISTRIBUTED BY:



REF NO.:

DWG31932

DESCRIPTION:

3.5 - 6 Gallon HDPE Pail Cover, EPDM Gasket, with Rieke FS10 Spout

### DISCLAIMER

THIS INFORMATION IS PROVIDED AS A GENERAL GUIDE, INCLUDING DIMENSIONS. IT IS THE CUSTOMER'S RESPONSIBILITY TO SELECT THE PROPER CONTAINER FOR PRODUCT AND APPLICATION COMPATIBILITY.