



# Assembly Instructions

**ITEM NO.D4124-20**  
 CHESTNUT RIDGE DINING CHAIR (2PER CARTON)  
 (2PCS/CTN)

Thank you for purchasing this quality product. Be sure to check all packing materials carefully for small parts, which may have come loose inside the carton during shipment. Identify and count all items and compare with the PARTS LIST and/or HARDWARE LIST shown below.



Please read the instructions thoroughly before assembly.

1. We recommend that you assemble this product with the assistance of another person; this will make the assembly easier, and will help eliminate damage to the product or injury to persons during assembly.
2. Please do not tighten screws or bolts until the assembly is completed.
3. To level the chairs or table, before tightening all the screws, the chairs or table must be placed on a flat surface and then tighten the screws.
4. Please put all parts on a non-abrasive floor before assembly and follow the assembly steps to assemble your newly purchased product correctly and efficiently.

### PARTS LIST

NO.	COMPONENT	SKETCH	QTY
A	CHAIR BACK		2PCS
B	SEAT		2PCS
C	LEFT SIDE FACING (LSF) LEG		2PCS
D	RIGHT SIDE FACING (RSF) LEG		2PCS
E	LEFT SIDE FACING (LSF) STRETCHER		2PCS
F	RIGHT SIDE FACING (RSF) STRETCHER		2PCS

### HARDWARE LIST

NO.	COMPONENT	SKETCH	QTY
1	FLAT WASHER 1/4 DIA.		20 PCS
2	SPRING WASHER 1/4 DIA.		20 PCS
3	SHORT BOLT 1/4 x 1 1/2		4 PCS
4	MEDIUM BOLT 1/4 x 2 3/8		8 PCS
5	LONG BOLT 1/4 x 3 1/8		8 PCS
6	ALLEN KEY 5/32"		1 PC
7	WOOD SCREW #8 x 1 1/2"		8 PCS

WEIGHT CAPACITY (PER CHAIR) 250 LBS

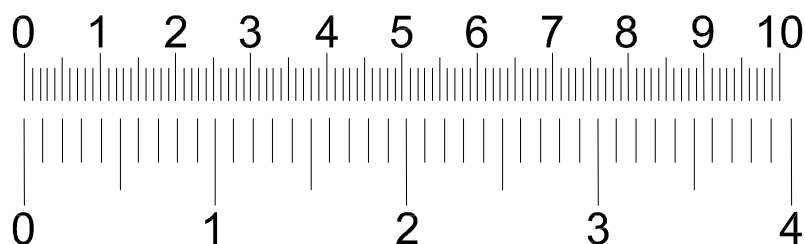

# Assembly Instructions

**ITEM NO.D4124-20**

CHESTNUT RIDGE DINING CHAIR (2PER CARTON)  
(2PCS/CTN)

## STEP 1

Place the chair back (A) on a soft and clean surface.  
Assemble the seat (B) with the chair back (A) by using Allen Key (6)  
with hardware 1,2, and 3  
\*Attention: DO NOT TIGHTEN THE BOLTS.

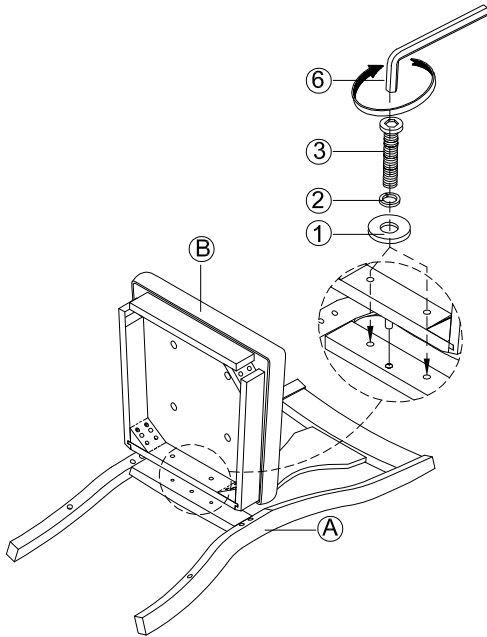

## STEP 2

Assemble the seat (B) with the back legs of the chair back (A) by using Allen Key (6) with hardware 1,2, and 5.  
\*Attention: DO NOT TIGHTEN THE BOLTS.

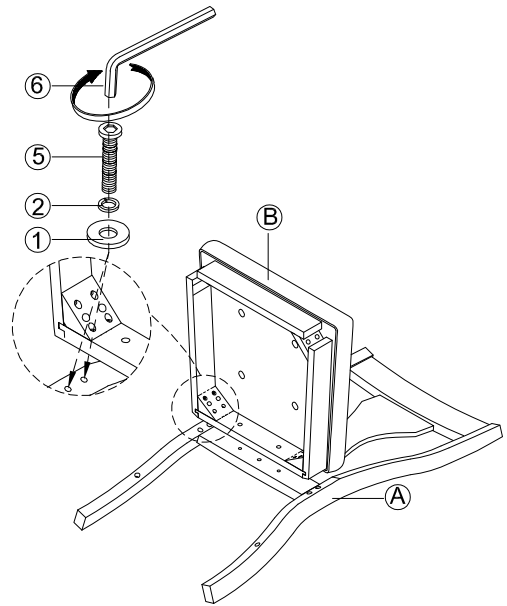

## STEP 3

Assemble the LSF Leg (C) and RSF Leg (D) with the seat (B) by using Allen Key (6) with hardware 1,2, and 4.  
\*Attention: DO NOT TIGHTEN THE BOLTS

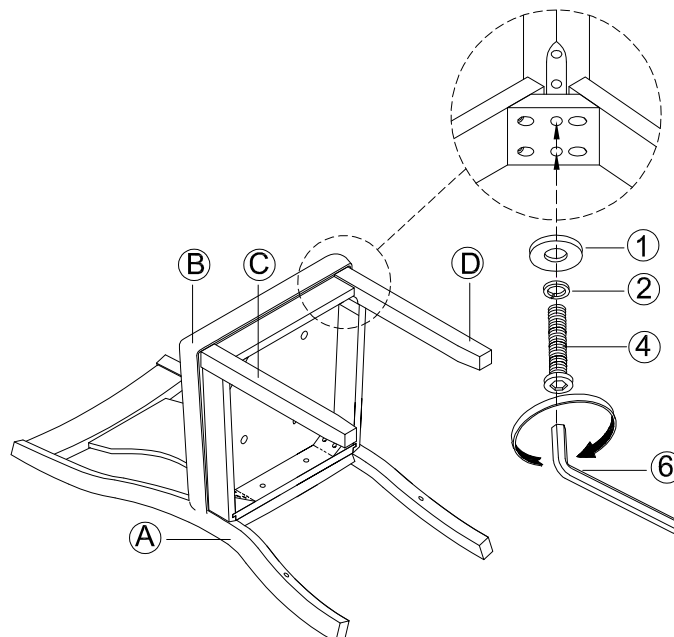

# Assembly Instructions

**ITEM NO.D4124-20**

CHESTNUT RIDGE DINING CHAIR (2PER CARTON)  
(2PCS/CTN)

## STEP 4

Install the LSF stretcher (E) and RSF stretcher (F) between the front legs (C & D) and the back legs of the chair back (A). Then assemble all the stretchers using a screwdriver with hardware 7.

**\*\*Attention: DO NOT TIGHTEN THE BOLTS OR THE SCREWS.**

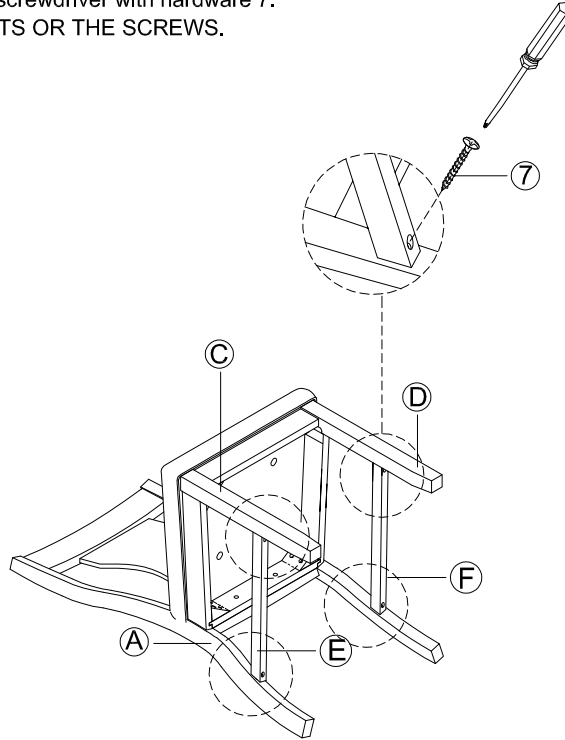

## STEP 5

To level the chair, stand the chair up on a flat surface and tighten all the bolts by using Allen Key (6) and tighten all the screws with a screwdriver.

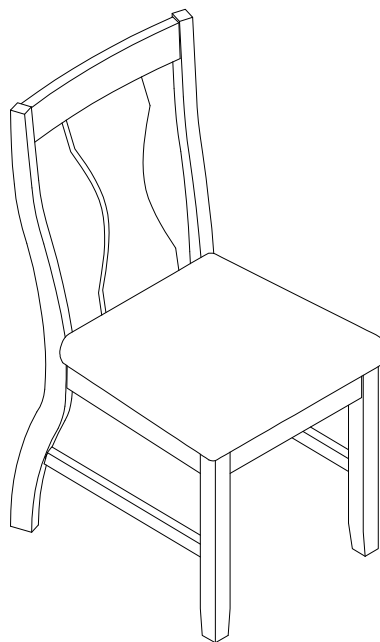

Fully Assembled Chair