

2306226 12x12 BARRINGTON GAZEBO Container Loading Diagram

(1 set=5 boxes 53 sets/40HQ, 20 pallets/ 40HQ, Gross Weight: 20080kg)

Top view

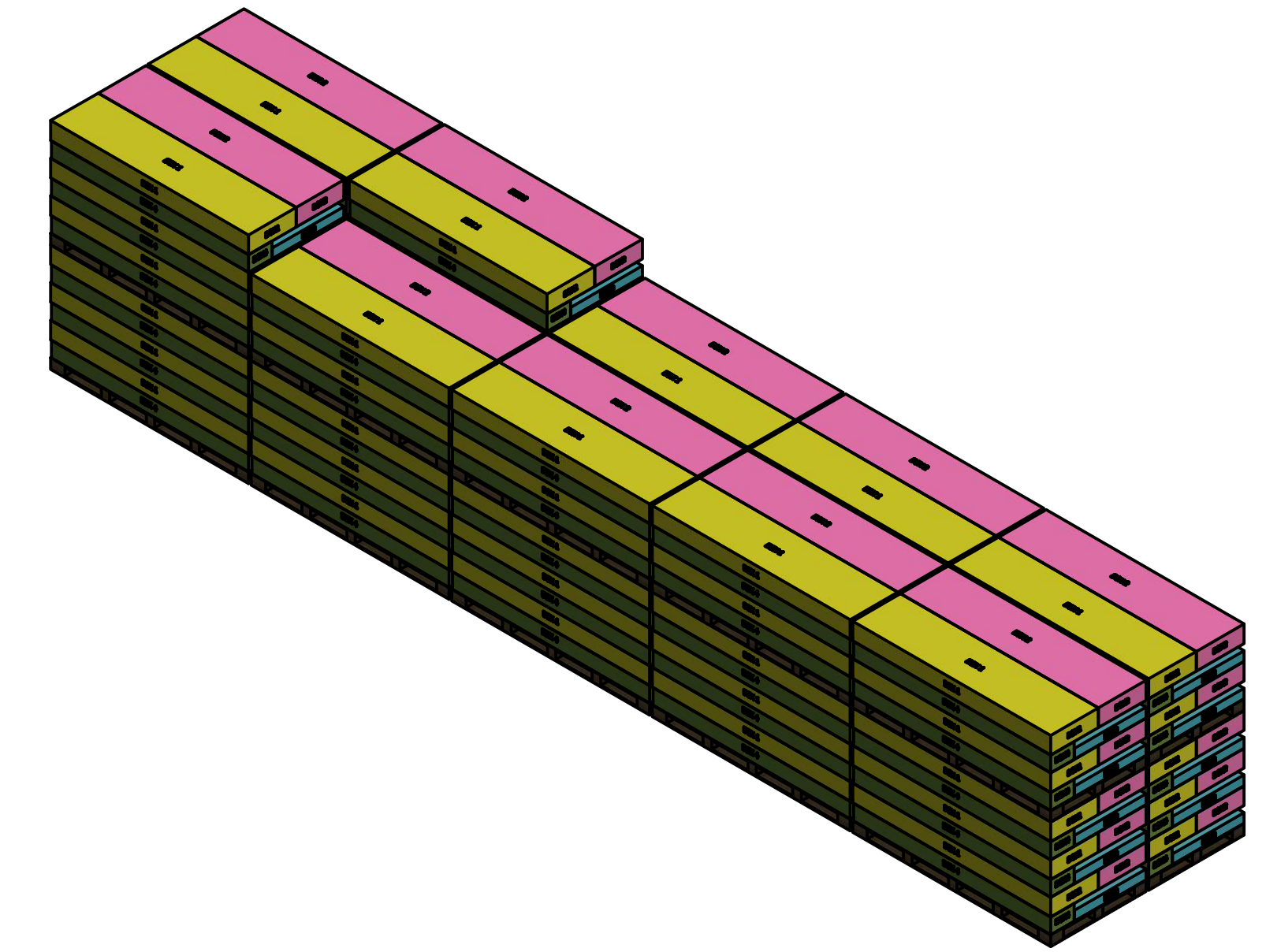
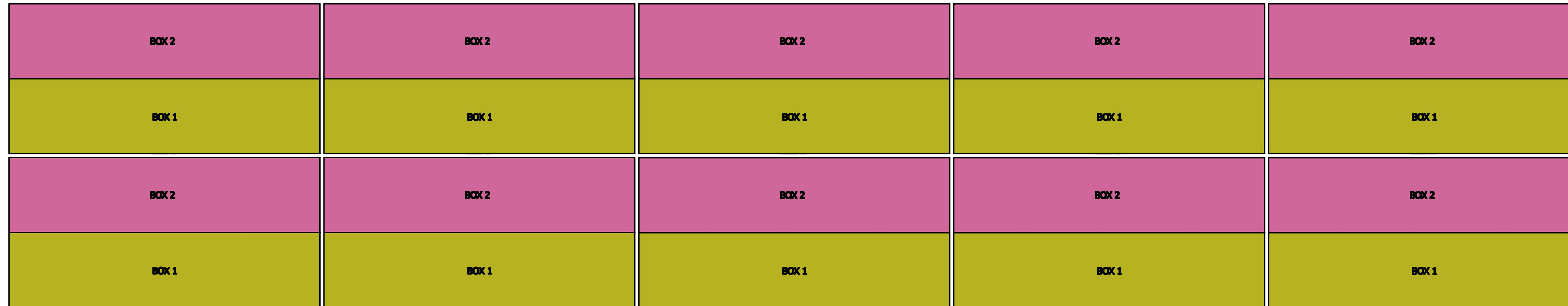

Side view

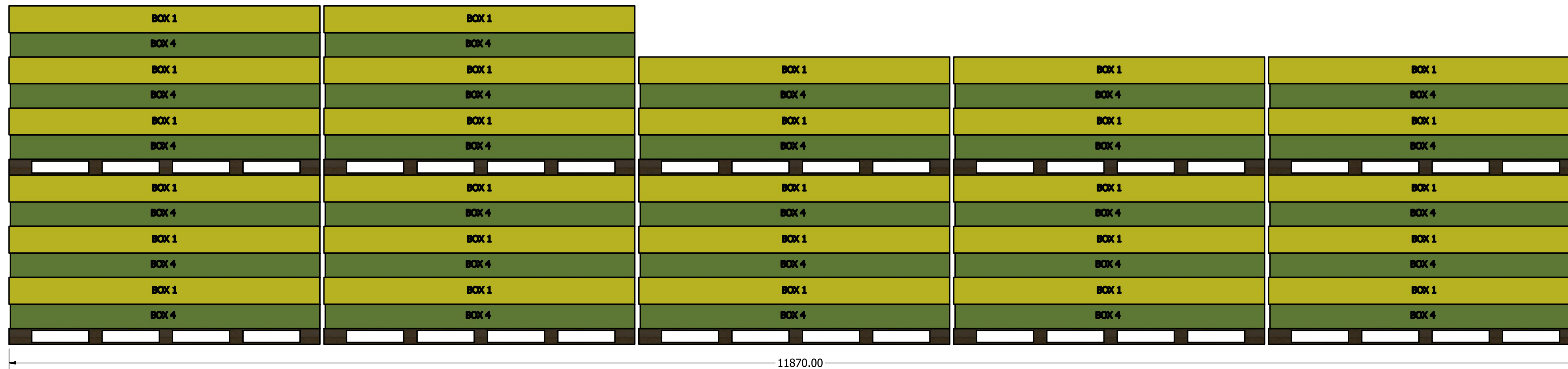

End view

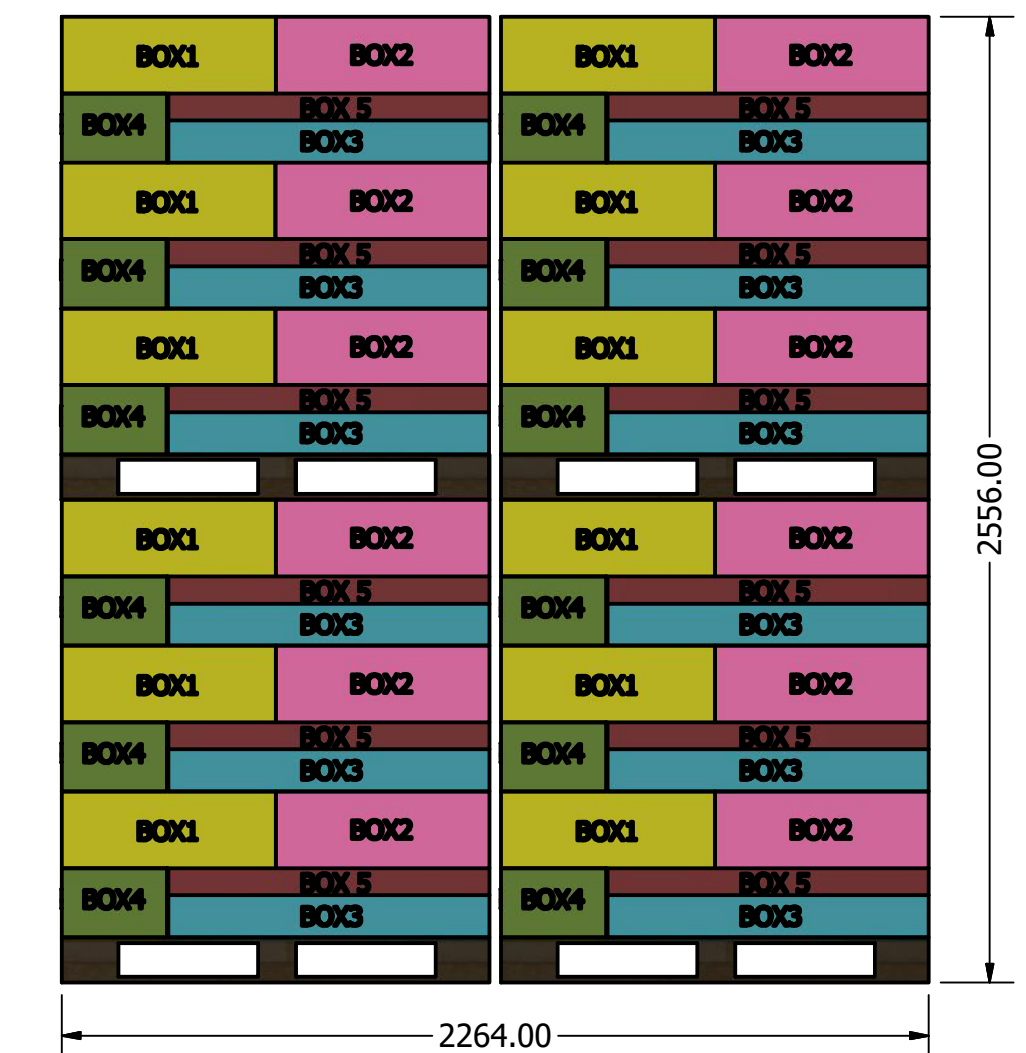

DRAWN Rudy	2019/8/19		
CHECKED		TITLE	
QA			
MFG			
APPROVED			
		SIZE D	DWG NO 2006522
		SCALE 1 / 20	REV SHEET 1 OF 1

Pallet A (3 sets/pallet)

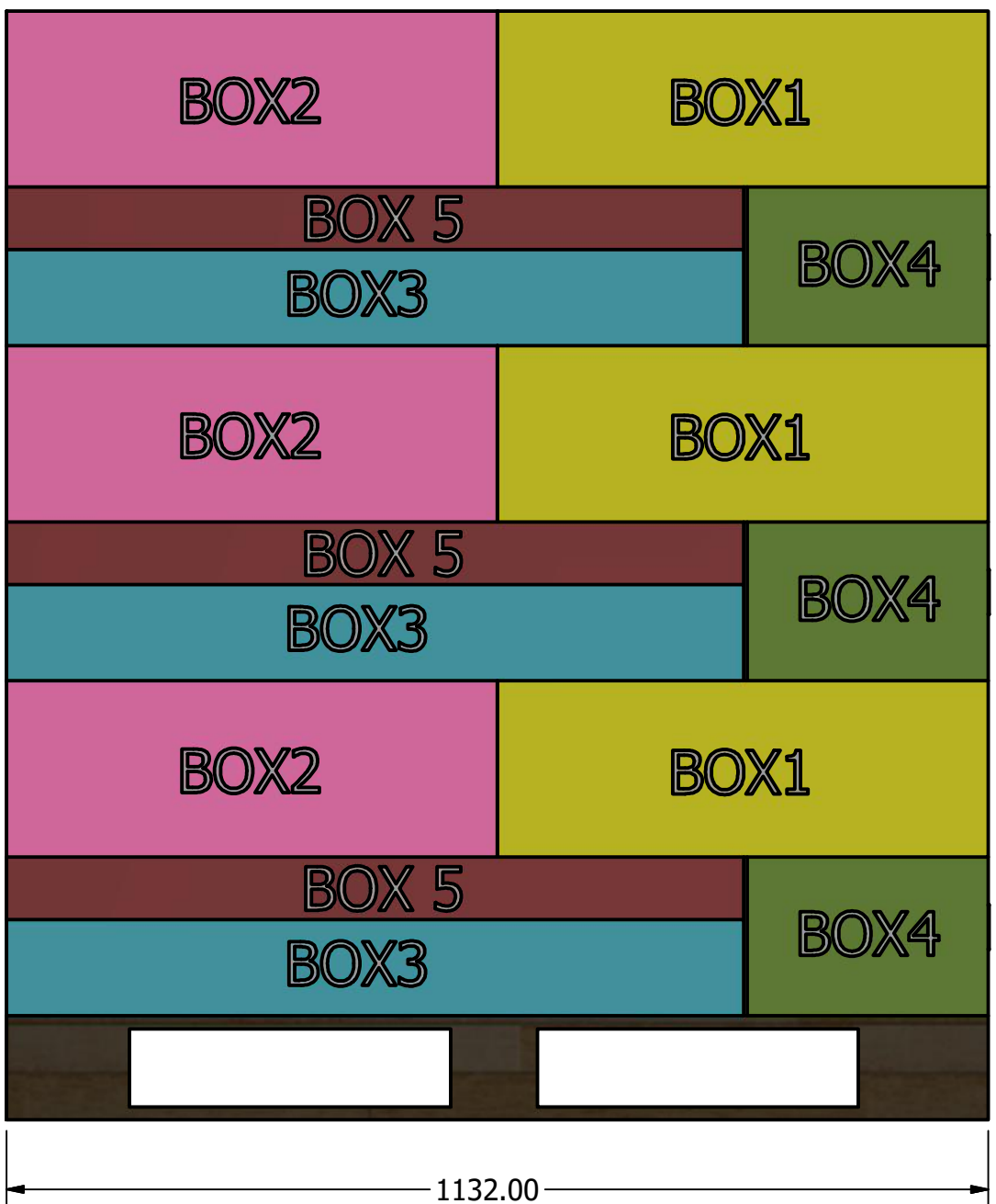
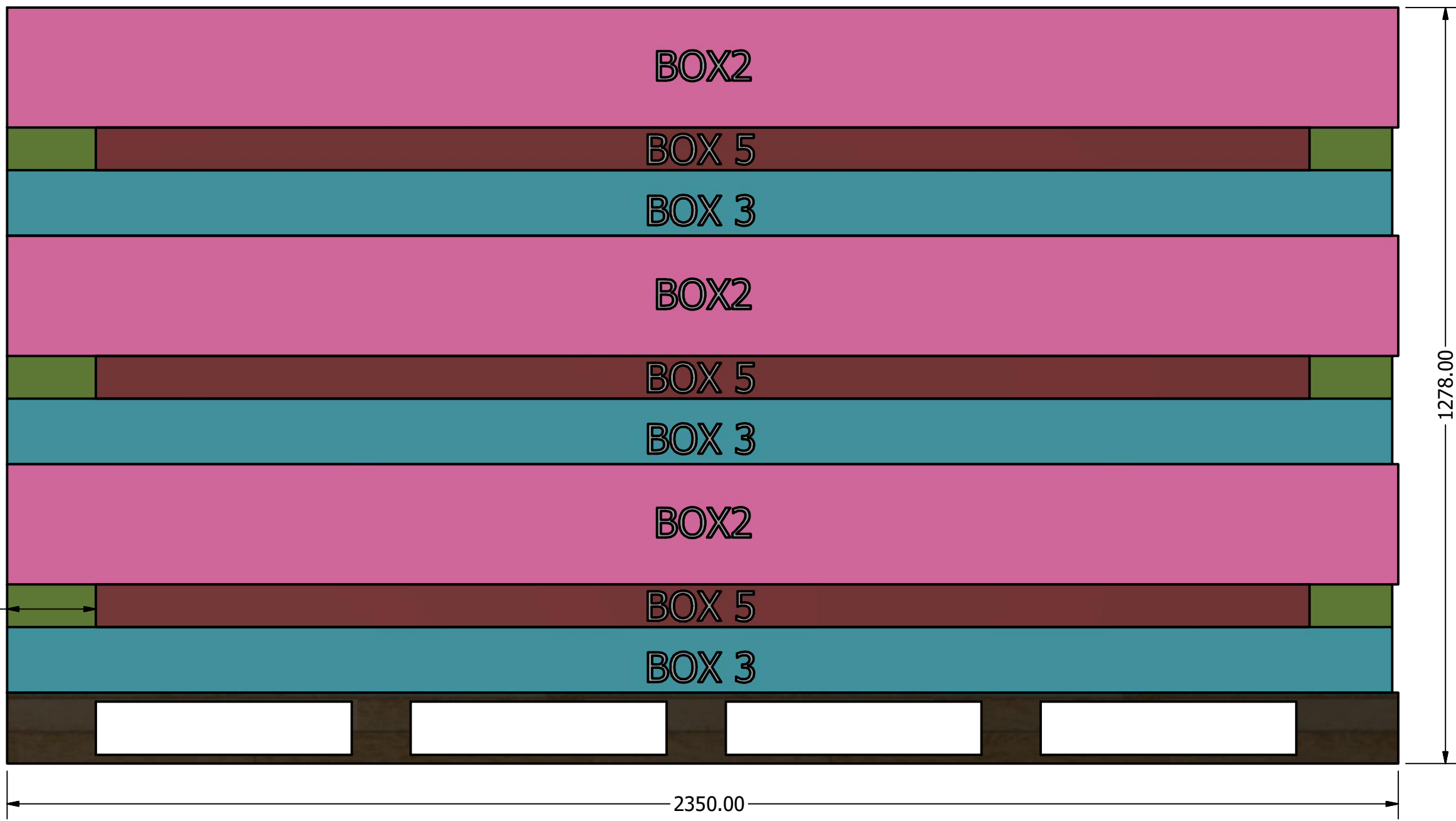
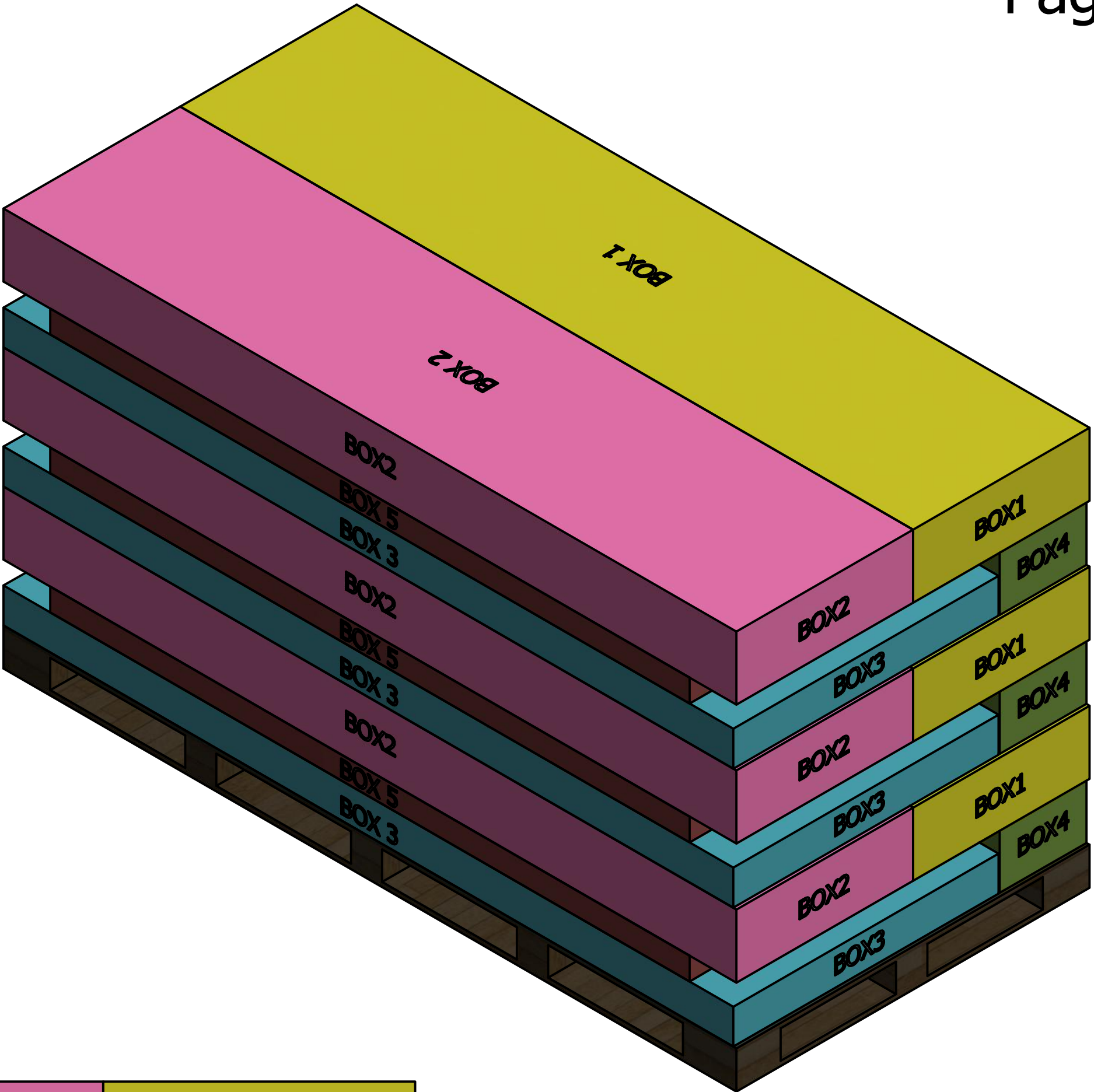
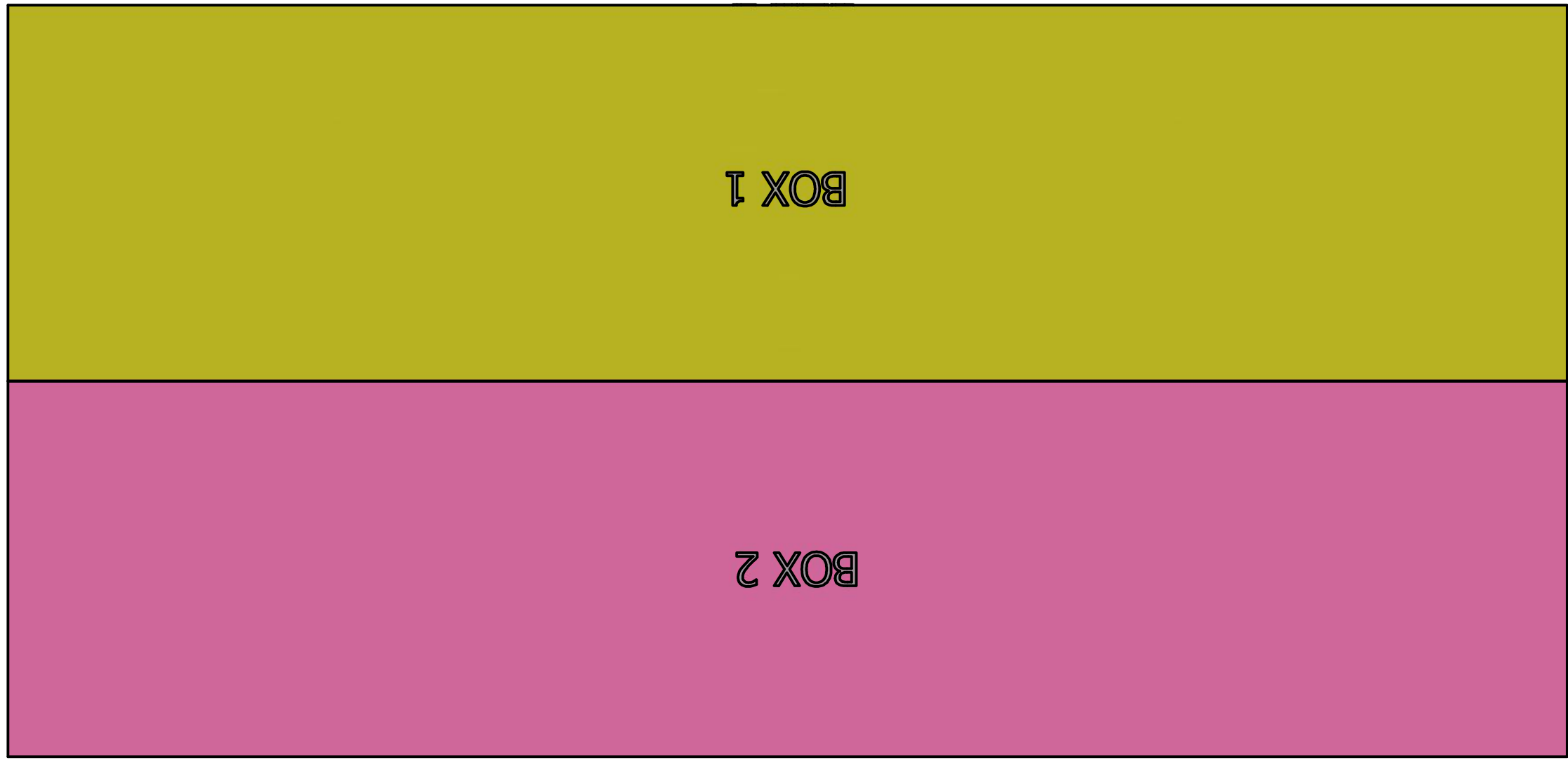

DRAWN Rudy	2019/8/19		
CHECKED		TITLE	
QA			
MFG			
APPROVED			
		SIZE D	DWG NO Pallet A
		SCALE 1 : 10	REV SHEET 1 OF 1

Pallet B (2 sets/pallet)

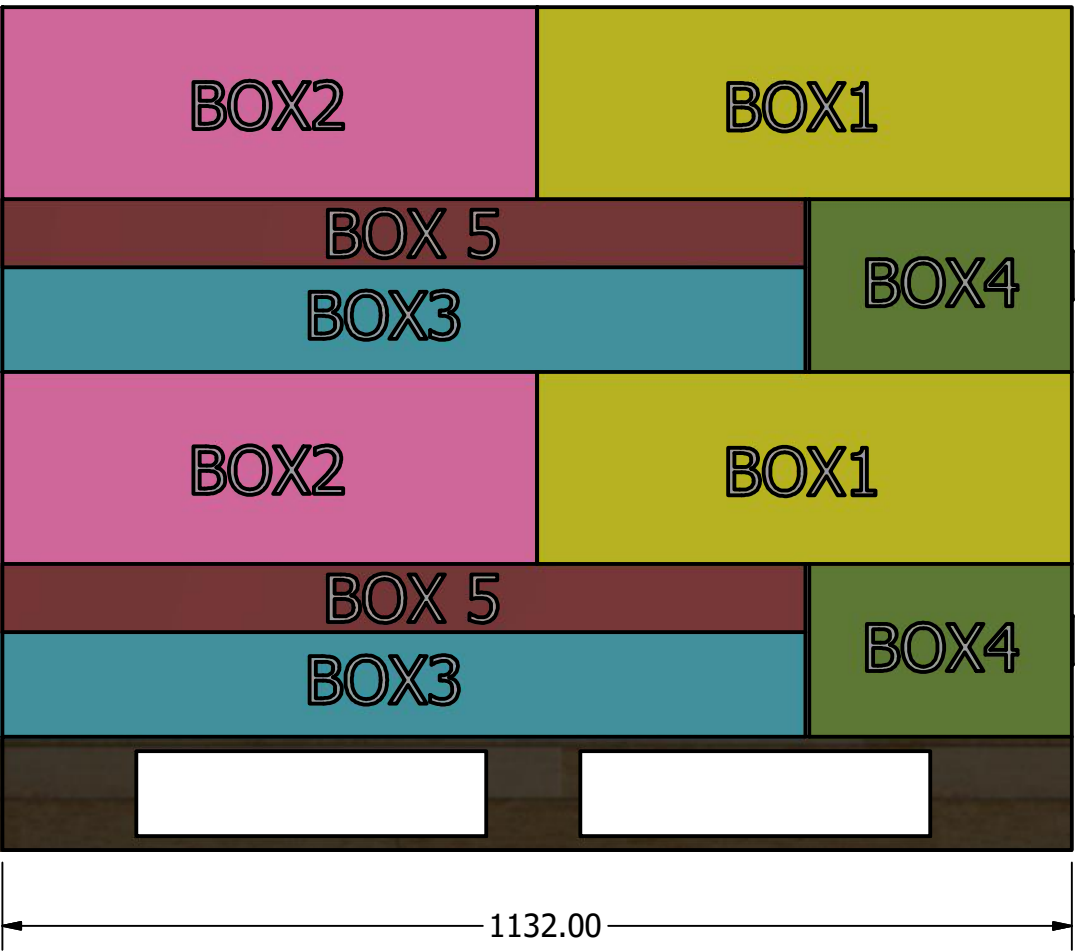
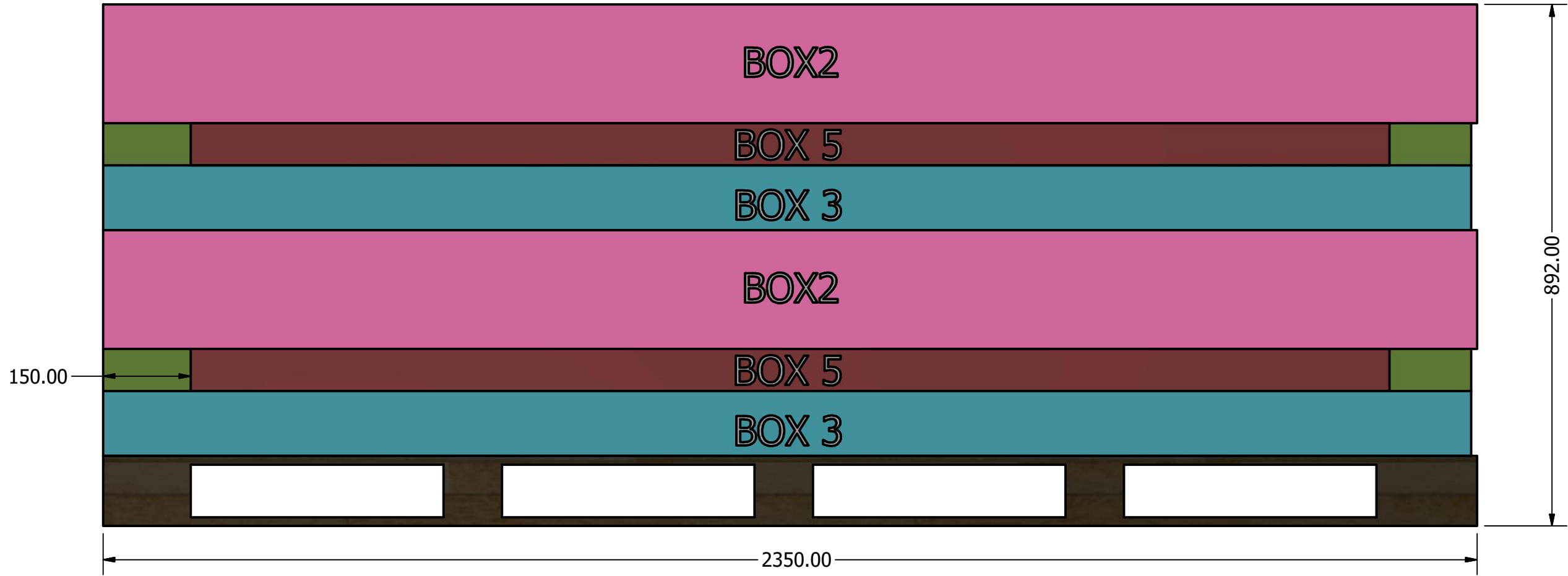
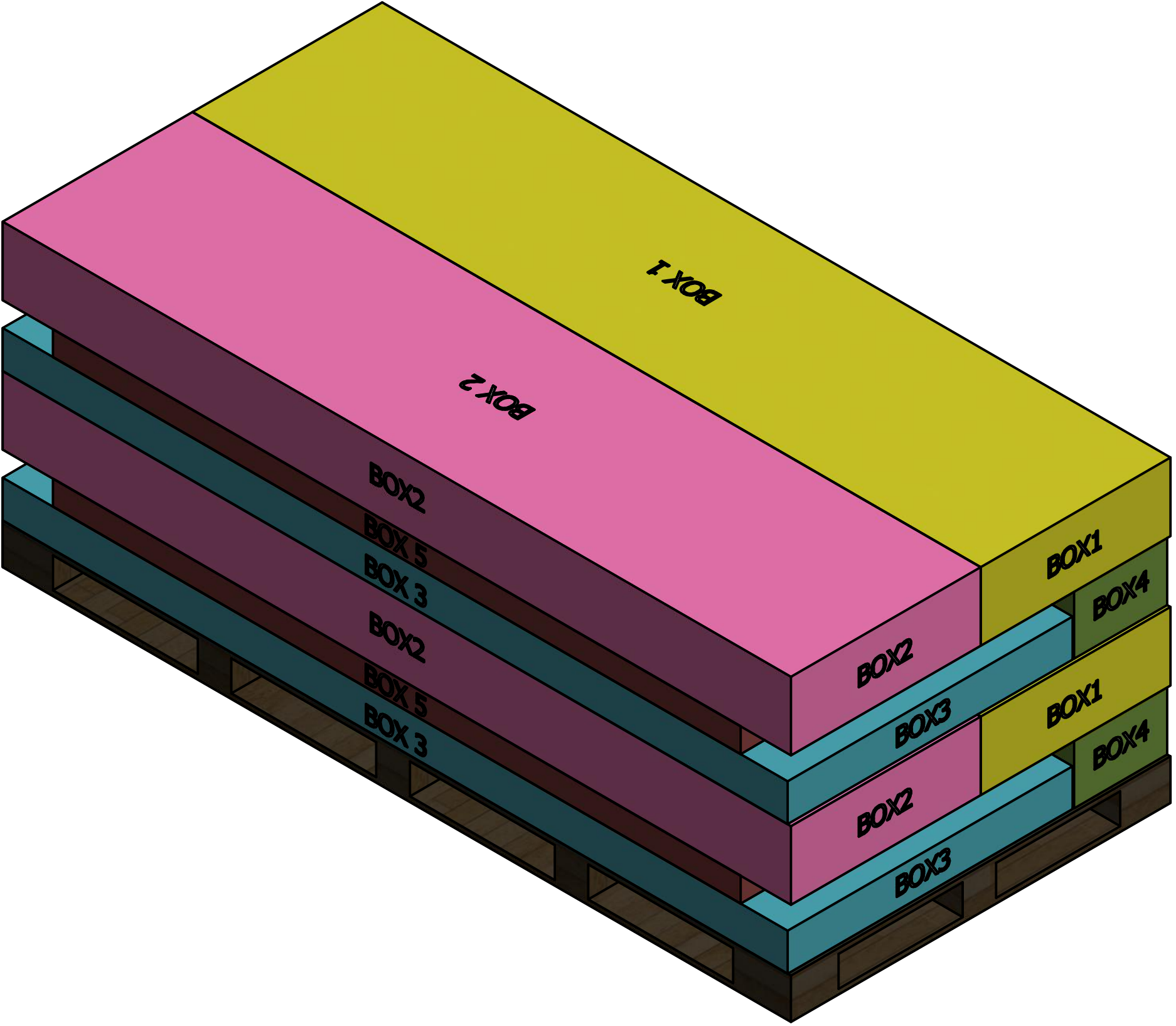
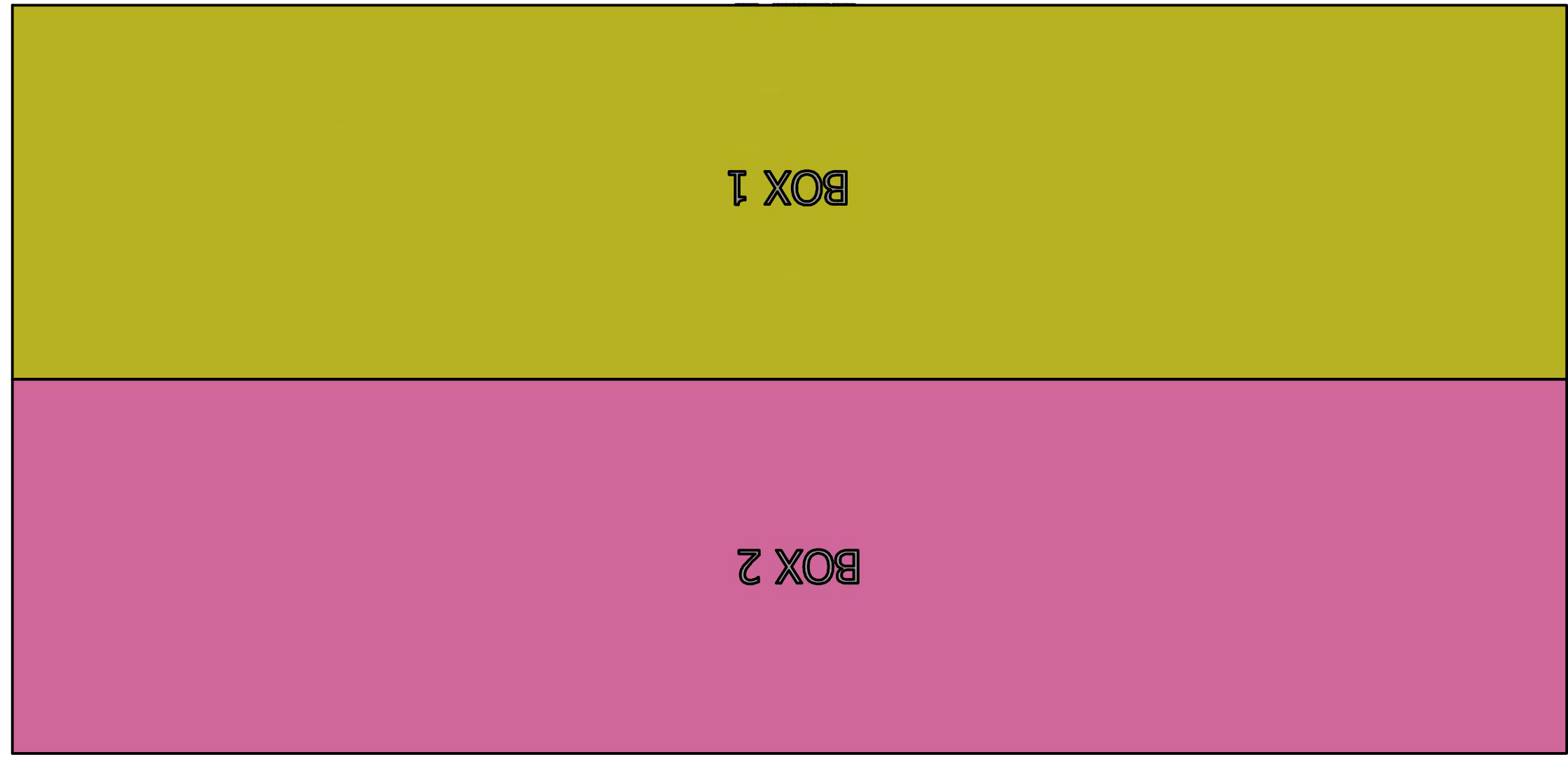

DRAWN Rudy	2019/8/19	TITLE	
CHECKED		TITLE	
QA		TITLE	
MFG		TITLE	
APPROVED		TITLE	
		SIZE D	DWG NO Pallet A
		SCALE 1: 8	REV
		SHEET 1 OF 1	

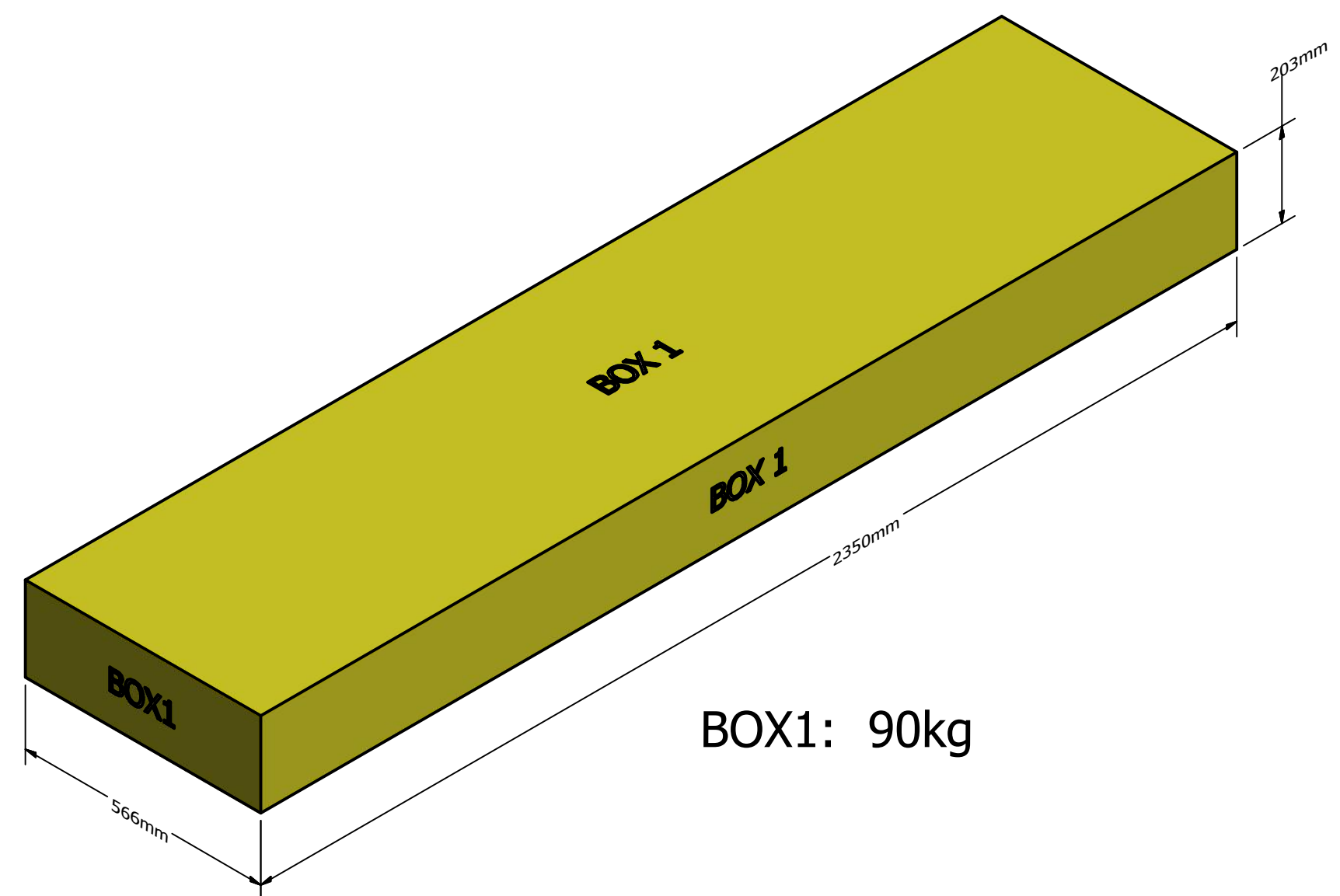

BOX1: 90kg

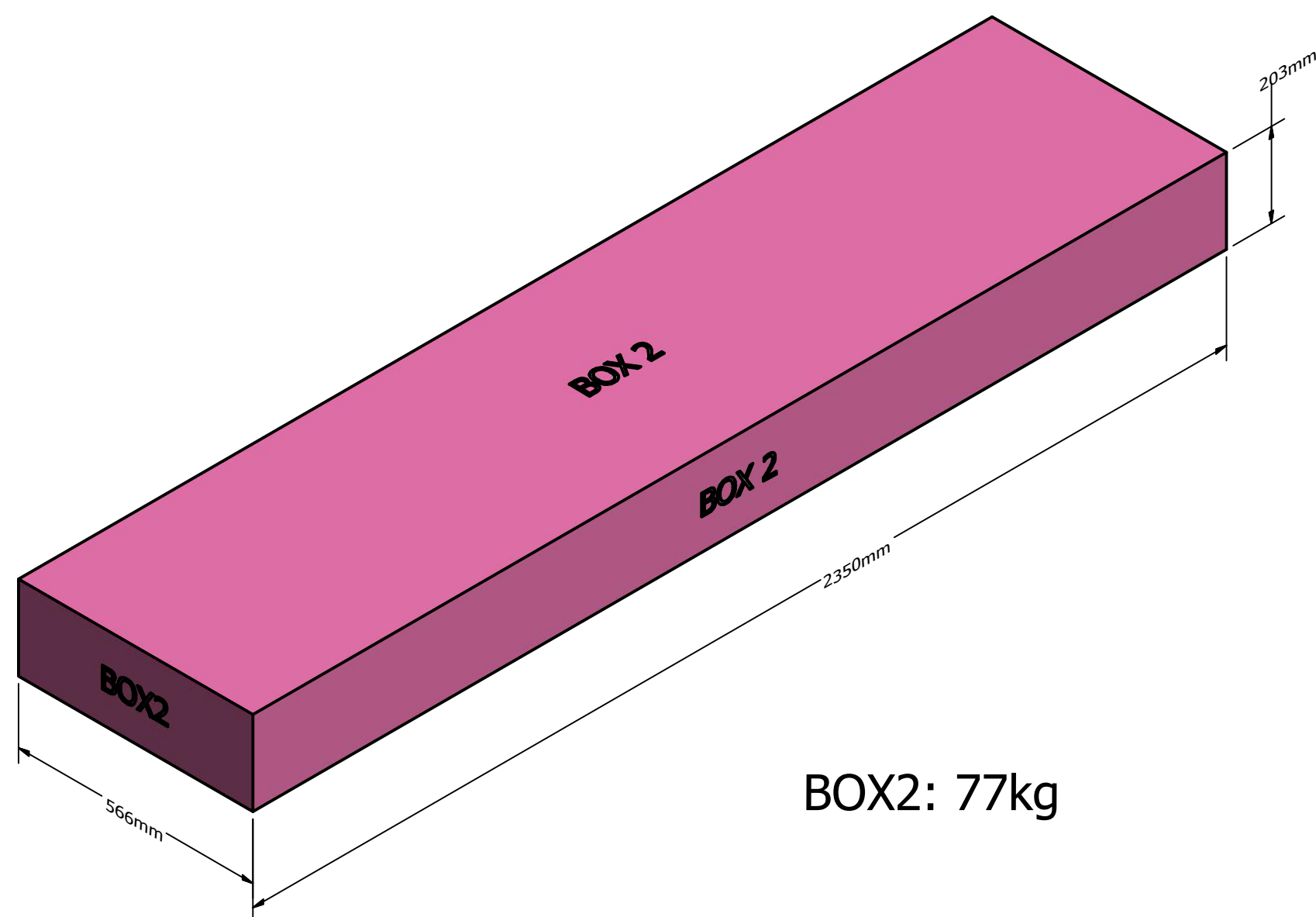

BOX2: 77kg

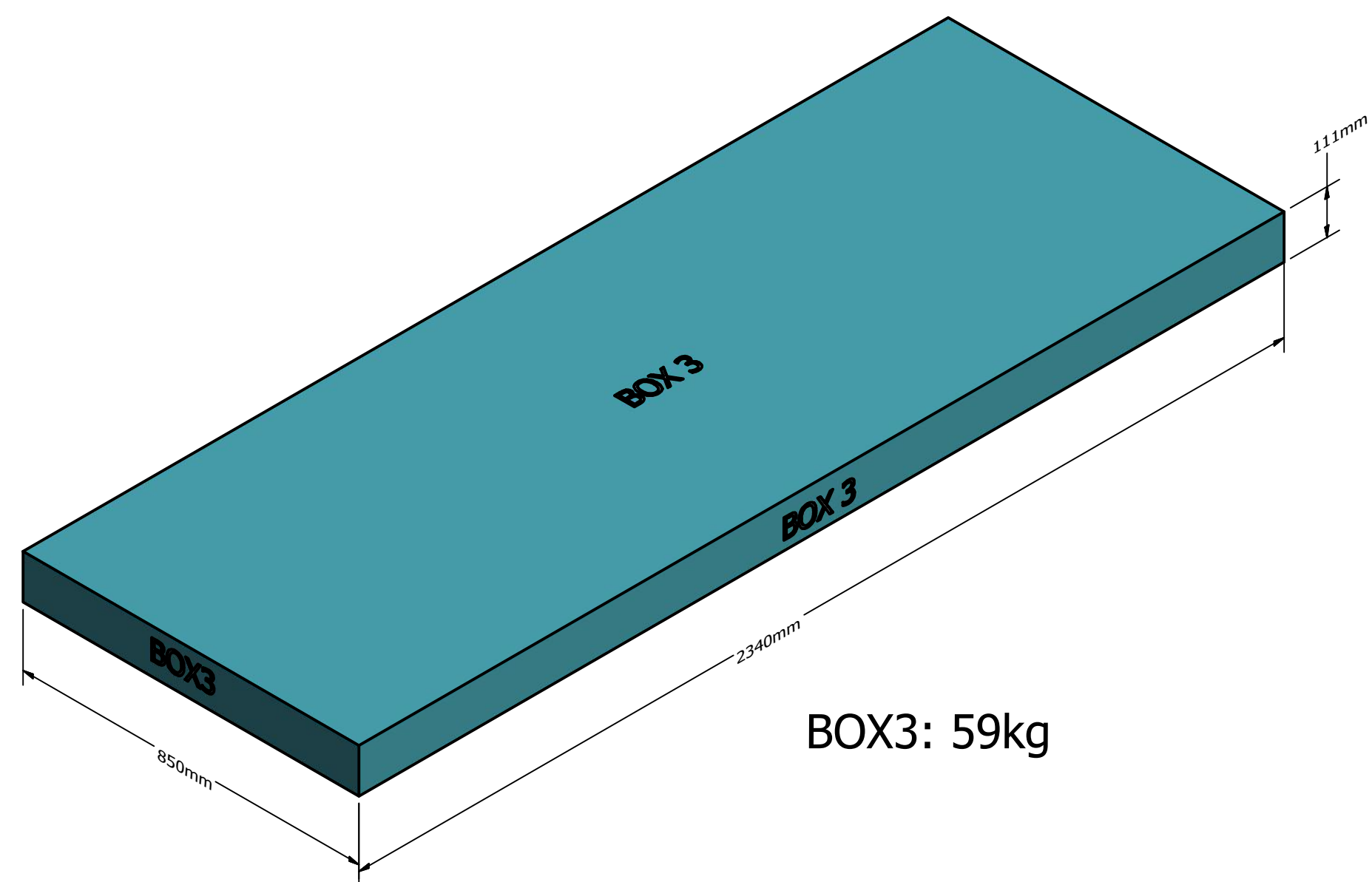

BOX3: 59kg

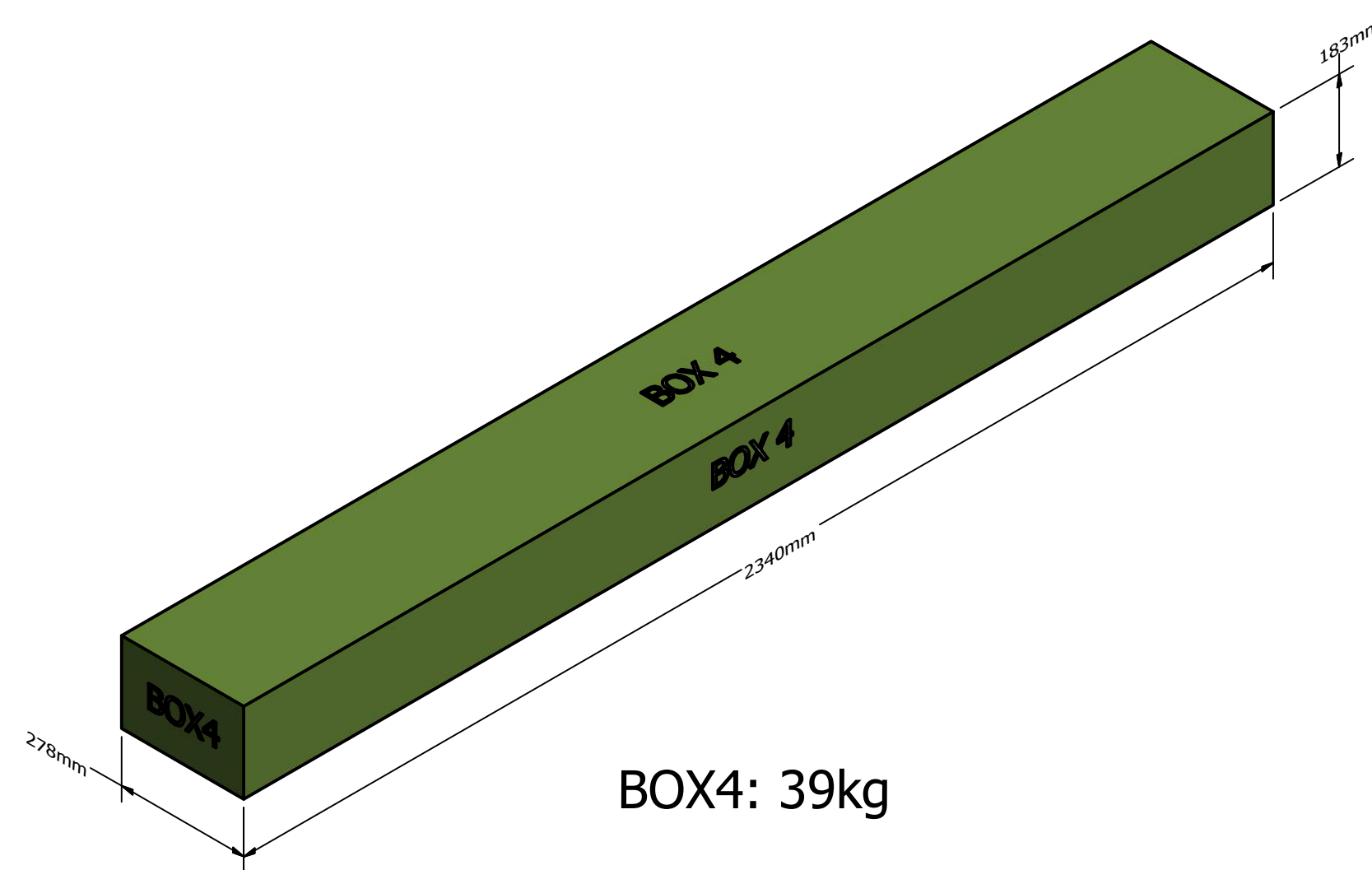

BOX4: 39kg

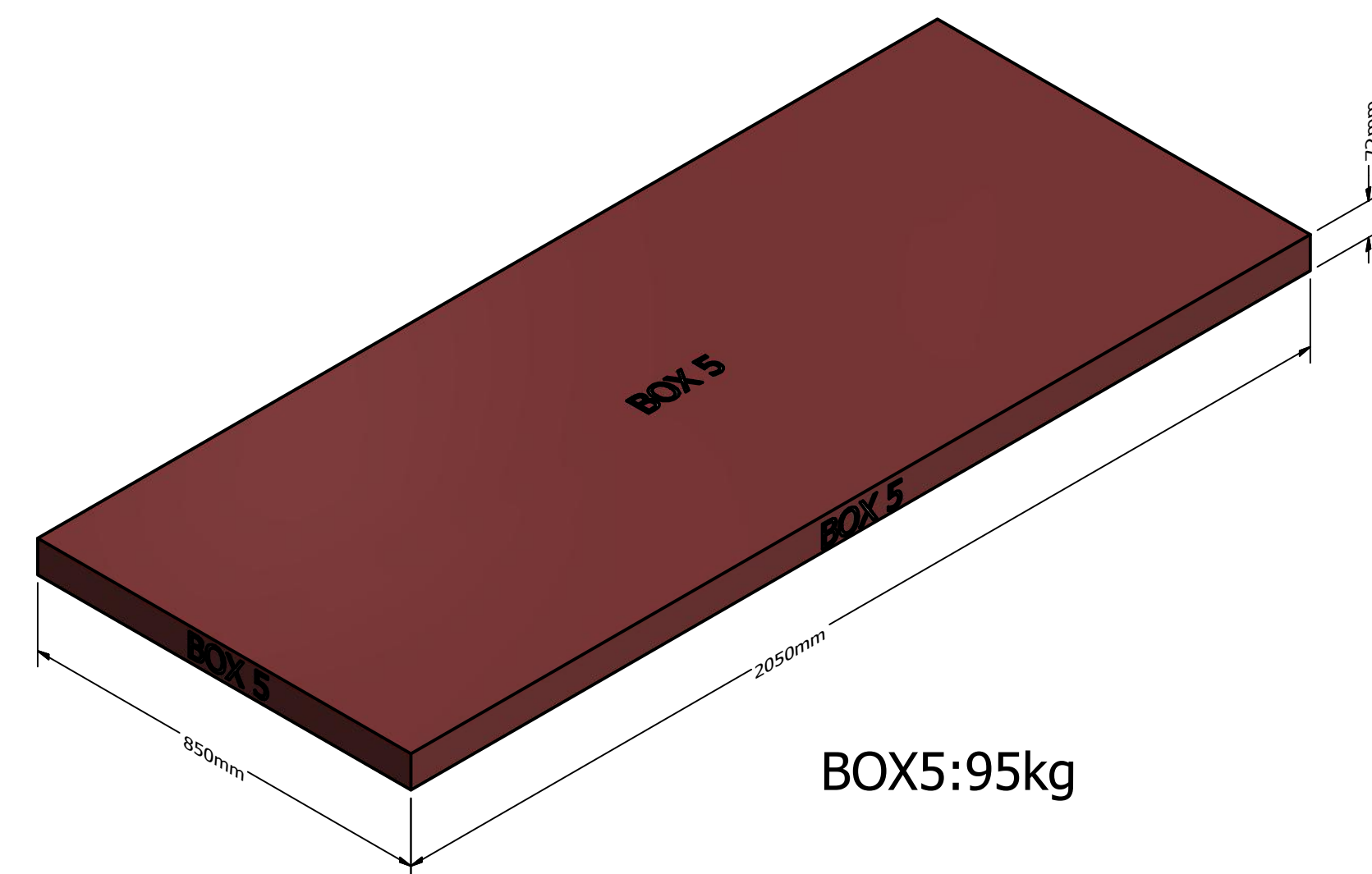

BOX5:95kg

DRAWN Rudy	2019/8/19	TITLE		
CHECKED				
QA				
MFG				
APPROVED		SIZE D	DWG NO Pallet A (详细)	REV
SCALE 1 / 10		SHEET 1 OF 1		