



Z508

9 [229] DIAMETER TOP EXTRA-HEAVY-DUTY DRAIN WITH SEDIMENT BUCKET

SPECIFICATION SHEET

TAG _____

Design and Dimensional Data (inches and [mm]) are Subject to Manufacturing Tolerances and Change Without Notice

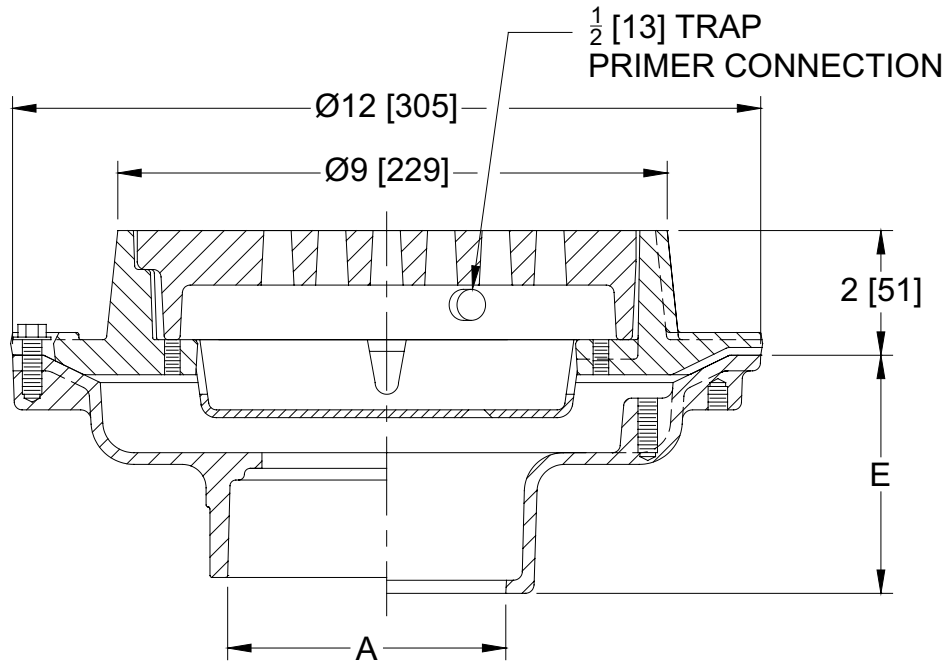

A- Pipe Size In.[mm]	Approx. Wt. Lbs. [kg]	Grate Open Area Sq. In. [cm2]
2, 3, 4 [51, 76, 102]	22 [10]	18 [116]
6 [152]	26 [12]	

ENGINEERING SPECIFICATION: ZURN Z508
 9" [229mm] Diameter top drain, Dura-Coated cast iron body with bottom outlet, seepage pan and combination membrane flashing clamp and frame with integrated trap primer and plug for extra-heavy-duty ductile deep flange slotted grate with sediment bucket.

OPTIONS (Check/specify appropriate options)

PIPE SIZE (ØA)

- 4 [102]
- 4 [102]
- 4 [102]
- 2, 3, 4 [51, 76, 102]
- 6 [152]
- 2, 3, 4 [51, 76, 102]

OUTLET (specify size)

- ___ IC Inside Caulk
- ___ IG Inside Gasket
- ___ IP Threaded
- ___ NH No-Hub
- ___ NH No-Hub
- ___ NL Neo-Loc

'E' BODY HT. DIM.

- 3-3/4 [95]
- 3-3/4 [95]
- 2-3/4 [70]
- 4-3/4 [121]
- 5-1/4 [133]
- 3-9/16 [90]

PREFIXES

- ___ Z D.C.C.I. Body and Top*
- ___ ZN D.C.C.I. Body with Polished Nickel Bronze Top (Add 3/16 [5] to 2 [51] Dim. and 3/4 [20] to 9 [229] Dim.)

SUFFIXES

- | | |
|---|---|
| ___ -AR Acid Resisting Epoxy Coated Cast Iron | ___ -TC Neo-Loc Test Cap Gasket |
| ___ -G Galvanized Cast Iron | (2, 3, 4 [51, 76, 102] NL Bottom Outlet Only) |
| ___ -S Secondary Strainer | ___ -TS Top Secured with Slotted Screws |
| ___ -SA Stabilizer Assy (See Z1036) | ___ -VP Vandal-Proof Secured Top |
| ___ -SC Solid Cover with Lift Handle | ___ -90 90° Threaded Side Outlet Body (4 [102] Size Only) |

* Regularly furnished unless otherwise specified

- ⚠ **WARNING:** Cancer and Reproductive Harm - www.P65Warnings.ca.gov
- ⚠ **ADVERTENCIA:** Cáncer y daño reproductivo - www.P65Warnings.ca.gov
- ⚠ **AVERTISSEMENT:** Cancer et effets néfastes sur la reproduction - www.P65Warnings.ca.gov

Zurn Industries, LLC | Specification Drainage Operation
 1801 Pittsburgh Avenue, Erie, PA 16502, Ph. 855.663.9876

In Canada | Zurn Industries Limited
 7900 Goreway Drive, Unit 10, Brampton, Ontario L6T 5W6, Ph. 877.892.5216

www.zurn.com

Rev.	L
Date:	09/03/25
C.N. No.	147159
Prod. Dwg. No.	Z508