

# Installation and Care Guide

## Diverter Valve

Français, page "Français-1"  
Español, página "Español-1"

1330584-2-A

THE BOLD LOOK  
OF **KOHLER**®

## Tools and Materials



Adjustable  
Wrench



Tape  
Measure



3/32" Hex  
Wrench



Solder

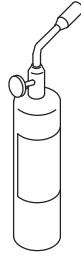

Propane  
Torch

## Before You Begin



**WARNING: Risk of personal injury.** This product is a diverter valve only. Do not use as a shut-off valve. Doing so would allow crossflow between the hot and cold water supplies and create a serious scalding hazard.

- Observe all local plumbing and building codes.
- Shut off the water supply.
- Provide an access panel for all installations.
- Only install this diverter valve to decks with a maximum thickness of 1-1/4" (32 mm).
- Carefully inspect waste and supply tubing for any sign of damage. Replace if needed.
- Remove all internal components of the diverter valve before soldering.** Kohler Co. recommends soldering supply and optional outlet connections to avoid potential leakage.

**NOTE:** Plumbing codes may require that a vacuum breaker be installed in-line to handshowers. Please consult with local plumbing codes. If a vacuum breaker is required, ensure that it is not installed between the handshower high-pressure and interlock hoses.

## Layout

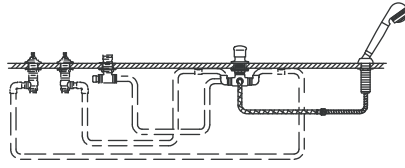
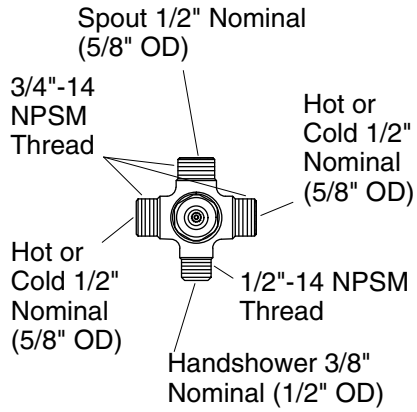

### 1. Diverter Configuration

- The small port is for the supplied handshower hose.
- The port directly across from the small port is for the bath spout. Default flow is through this port.
- The remaining two ports are for the hot and cold water. These connections are interchangeable. If you will only use one inlet supply port, cap the other inlet supply port.

### 2. Lay Out the Components

- Verify the location of the components, and the orientation of all ports.

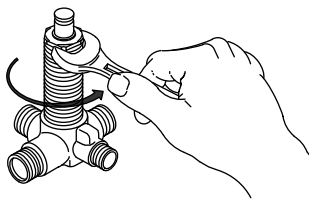
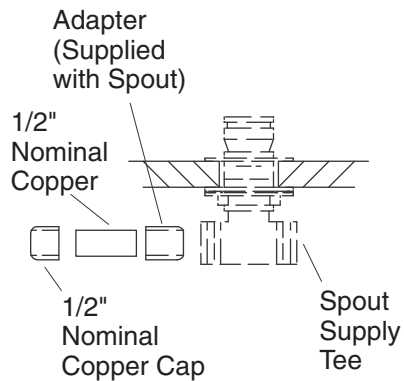

### 3. Preparation

- Provide an access panel for all installations.
- Allow for access to the connection between the shower high-pressure hose and the shower interlock hose.

**NOTE:** For easiest installation, do not install the bath unit until all soldering (except supplies) is complete. Then install the bath and connect the supplies.

- If used, install the bath spout shank at this time according to the spout installation instructions. If possible, do not install the finished trim until all other installations and construction are completed.
- **For spouts with a supply tee:** Add an adapter and a 1/2" copper tube. Sweat solder the connection. Cap to close the extra port.
- Install the valve bodies according to the valve body installation instructions.
- Loosely attach the valve bodies.
- Follow the handle installation instructions to temporarily install the handles. Adjust the valve height before connecting the lines to the diverter valve or supply.
- Use a wrench to loosen the cartridge assembly from the diverter body. Continue to unthread the assembly to remove.
- Set the assembly aside. Protect the seals and O-rings from becoming dirty, damaged, or misaligned.

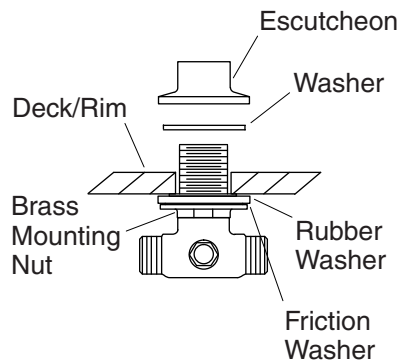

#### 4. Install the Diverter

##### For Finished Deck Installations

- At the diverter install location, drill a 1-1/2" (38 mm) hole.

##### For All Installations

**NOTE:** You may need assistance to align and secure the diverter.

- Thread the mounting nut all the way down onto the diverter body.
- Slide the friction washer and rubber washer over the diverter body, and down to the mounting nut.
- Insert the diverter body through the hole.
- Slide the washer onto the diverter body.
- Thread the escutcheon onto the diverter body until the escutcheon bottoms out on the diverter body. This will allow ample clearance for proper handle function.
- Align the inlets and outlets.
- Handtighten the mounting nut.

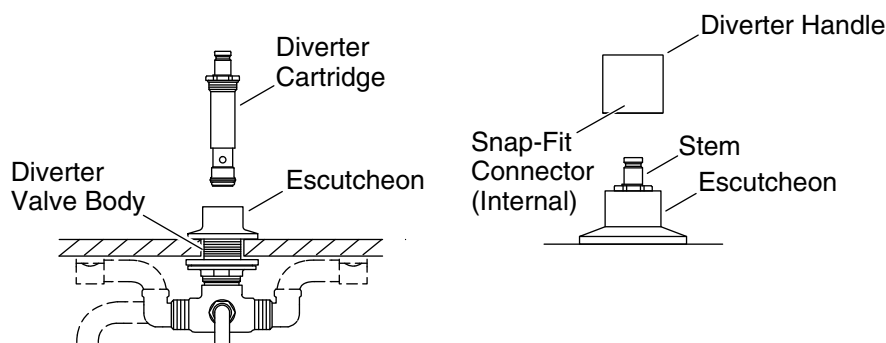

## 5. Complete the Diverter Installation

**CAUTION: Risk of product damage.** Verify that the diverter body is secure before removing the cartridge. If not secured, the process of removing the cartridge may damage the pipe and connections.

**CAUTION: Risk of product damage.** Excessive heat will damage the internal plastic components. Do not apply excessive heat while soldering. Direct the torch flame away from the brass body. Only apply direct heat to the connectors and extensions.

**IMPORTANT!** If there is limited access to the solder connections, or if any other risk of excessive heat being applied to the brass body exists, remove the cartridge before soldering. If you remove the cartridge, protect the seals and O-rings from becoming dirty, damaged, or misaligned.

- If not already removed, remove the diverter cartridge assembly.
- Dry fit all piping and connectors.
- Solder piping for the optional spout or wall shower.
- Connect the hot and cold lines from the valves to the diverter.
- While supporting from below, carefully install and wrench-tighten the cartridge assembly into the diverter body.
- Wrench-tighten the diverter valve mounting nut.
- Install the diverter handle by pressing it firmly onto the stem so it snaps onto the stem with an audible "click."

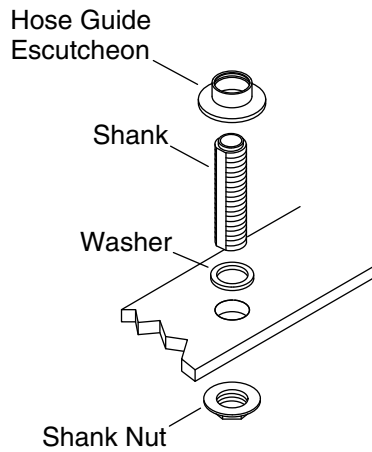

## 6. Install the Hose Guide

### For Deck-Mount Installations

- From the top of the finished deck, drill a 1-1/4" (32 mm) mounting hole.

### For All Installations

- Thread the escutcheon onto the shank.
- Slide the washer onto the shank.
- Insert the shank assembly into the mounting hole.
- Thread the shank nut onto the shank until snug against the underside of the mounting surface.

## 7. Complete the Installation

- Complete the installation of the valve, valve trim, and any other components according to the instructions packed with the product.
- Ensure that all connections are tight.
- Open the drain.
- Turn on the water supply and check for leaks. Repair as needed.
- Open both hot and cold valves, and run water through the spout (if installed) to remove debris. Check for leaks.
- Check the handshower for smooth operation.
- Confirm proper diverter operation.

### **Complete the Installation (cont.)**

- Turn the cold and hot handles OFF and then ON. Verify that the water flow is diverted back to the spout, and that the handshower is OFF.
- Turn the valves to the closed position.

### **Care and Cleaning**

For best results, keep the following in mind when caring for your KOHLER product:

- Use a mild detergent such as liquid dishwashing soap and warm water for cleaning. Do not use abrasive cleaners that may scratch or dull the surface.
- Carefully read the cleaner product label to ensure the cleaner is safe for use on the material.
- Always test your cleaning solution on an inconspicuous area before applying to the entire surface.
- Do not allow cleaners to sit or soak on the surface.
- Wipe surfaces clean and rinse completely with water immediately after cleaner application. Rinse and dry any overspray that lands on nearby surfaces.
- Use a soft, dampened sponge or cloth. Never use an abrasive material such as a brush or scouring pad to clean surfaces.

For detailed cleaning information and products to consider, visit [www.kohler.com/clean](http://www.kohler.com/clean). To order Care & Cleaning information, call 1-800-456-4537.

### **Warranty**

#### **KOHLER® Faucet Lifetime Limited Warranty**

Kohler Co. warrants its Faucets\* manufactured after January 1, 1997, to be leak and drip free during normal residential use for as long as the original consumer purchaser owns his or her home. If the Faucet should leak or drip during normal use, Kohler Co. will, free of charge, mail to the purchaser the cartridge necessary to put the Faucet in good working condition. This warranty applies only to Kohler Faucets installed in the United States of America, Canada or Mexico ("North America").

Kohler Co. also warrants all other aspects of the faucet or accessories

## Warranty (cont.)

("Faucet")\*, (except gold, non-Vibrant®, non-chrome finishes) to be free of defects in material and workmanship during normal residential use for as long as the original consumer purchaser owns his or her home. This warranty applies only to Kohler Faucets installed in North America. If a defect is found in normal residential use, Kohler Co. will, at its election, repair, provide a replacement part or product, or make appropriate adjustment. Damage to a product caused by accident, misuse, or abuse is not covered by this warranty. Improper care and cleaning will void the warranty\*\*. Proof of purchase (original sales receipt) must be provided to Kohler Co. with all warranty claims. Kohler Co. is not responsible for labor charges, installation, or other incidental or consequential costs. In no event shall the liability of Kohler Co. exceed the purchase price of the Faucet.

If the Faucet is used commercially or is installed outside of North America, or if the finish is gold, non-Vibrant or a painted or powder coated color finish, Kohler Co. warrants the Faucet to be free from defects in material and workmanship for one (1) year from the date the product is installed, under Kohler Co.'s standard one-year limited warranty.

If you believe that you have a warranty claim, contact Kohler Co., either through your Dealer, Plumbing Contractor, Home Center or E-tailer, or by writing Kohler Co., Attn.: Customer Care Center, 444 Highland Drive, Kohler, WI 53044, USA. Please be sure to provide all pertinent information regarding your claim, including a complete description of the problem, the product, model number, color, finish, the date the product was purchased and from whom the product was purchased. Also include your original invoice. For other information, or to obtain the name and address of the service and repair facility nearest you, call 1-800-4-KOHLER (1-800-456-4537) from within the USA and Canada, and 001-800-456-4537 from within Mexico, or visit [www.kohler.com](http://www.kohler.com) within the USA, [www.ca.kohler.com](http://www.ca.kohler.com) from within Canada, or [www.mx.kohler.com](http://www.mx.kohler.com) in Mexico.

**KOHLER CO. AND/OR SELLER ARE PROVIDING THESE WARRANTIES IN LIEU OF ALL OTHER WARRANTIES, EXPRESSED OR IMPLIED, INCLUDING BUT NOT LIMITED TO THE IMPLIED WARRANTIES OF MERCHANTABILITY AND FITNESS FOR A PARTICULAR PURPOSE. KOHLER CO. AND/OR SELLER DISCLAIM ALL LIABILITY FOR SPECIAL, INCIDENTAL OR CONSEQUENTIAL DAMAGES. Some states/provinces do not allow limitations of how long an implied warranty lasts or the exclusion or limitation of such damages, so these limitations and exclusions may not apply to you. This warranty gives the consumer specific legal rights. You may also have other rights that vary from**

**Warranty (cont.)**

state/province to state/province.

**This is Kohler Co.'s exclusive written warranty.**

\*Trend<sup>®</sup> faucets, MasterShower<sup>®</sup> tower, BodySpa systems and components; WaterHaven<sup>®</sup> tower, systems and components; Tripoint<sup>®</sup> faucets, Polished Gold, non-Vibrant and painted or powder coated finishes, fittings; all items within the "Fixture Related" section of the Kohler Faucets Price Book, drains, Duostrainer<sup>®</sup> sink strainers, soap/lotion dispensers, Moxie<sup>®</sup> Wireless Speaker; and faucets used in commercial settings, and outside North America, are covered by Kohler Co.'s one-year limited warranty.

\*\*Never use cleaners containing abrasive cleansers, ammonia, bleach, acids, waxes, alcohol, solvents or other products not recommended for chrome. This will void the warranty.