

# ASSEMBLY INSTRUCTION

## MISSION BACK SIDE CHAIR

**A** CHAIR BACK

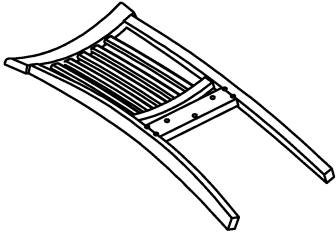

1 pc

**B** WOODEN SEAT



1 pc

**C** FRONT LEG

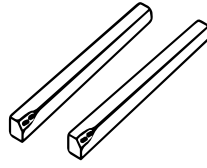

2 pcs

**D** BOLT  
 $\text{Ø } \frac{1}{4}'' \times 75 \text{ mm}$



4 pcs

**E** BOLT  
 $\text{Ø } \frac{1}{4}'' \times 40 \text{ mm}$



3 pcs

**F** HEX NUT  
 $\text{Ø } \frac{5}{16}'' \times 12 \text{ mm}$

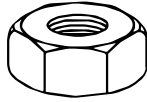

4 pcs

**G** FLAT WASHER  
 $\text{Ø } \frac{5}{16}'' \times 19 \text{ mm}$

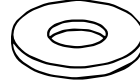

11 pcs

**H** LOCK WASHER  
 $\text{Ø } \frac{5}{16}'' \times 13 \text{ mm}$



11 pcs

**I** ALLEN KEY  
4 mm



1 pc

**J** WRENCH  
12 mm

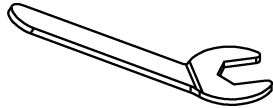

1 pc

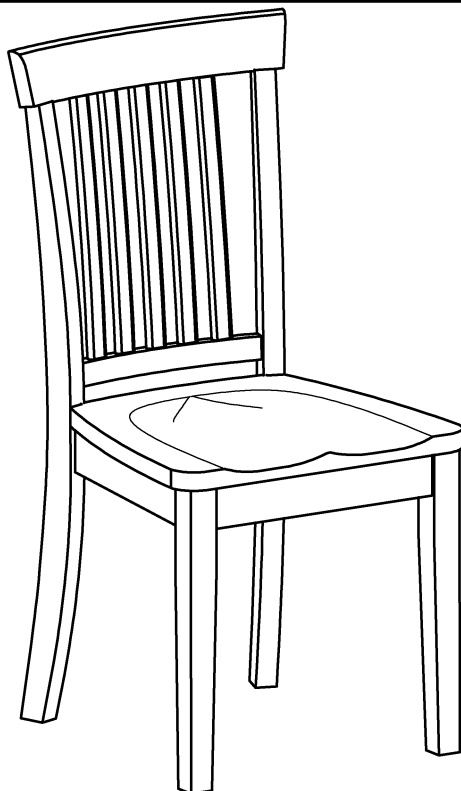

This page lists all the contents included in the box. Please take the time to identify the hardware as well as the individual components to this product. As you unpack and prepare for assembly, place the contents on a carpeted or padded area to protect them from damage.

**1** Attach the Front Leg (C) to Wooden Seat (B) using Flat Washer (G), Lock Washer (H) and Hex Nut (F) by Wrench (J). Do not fully tighten.

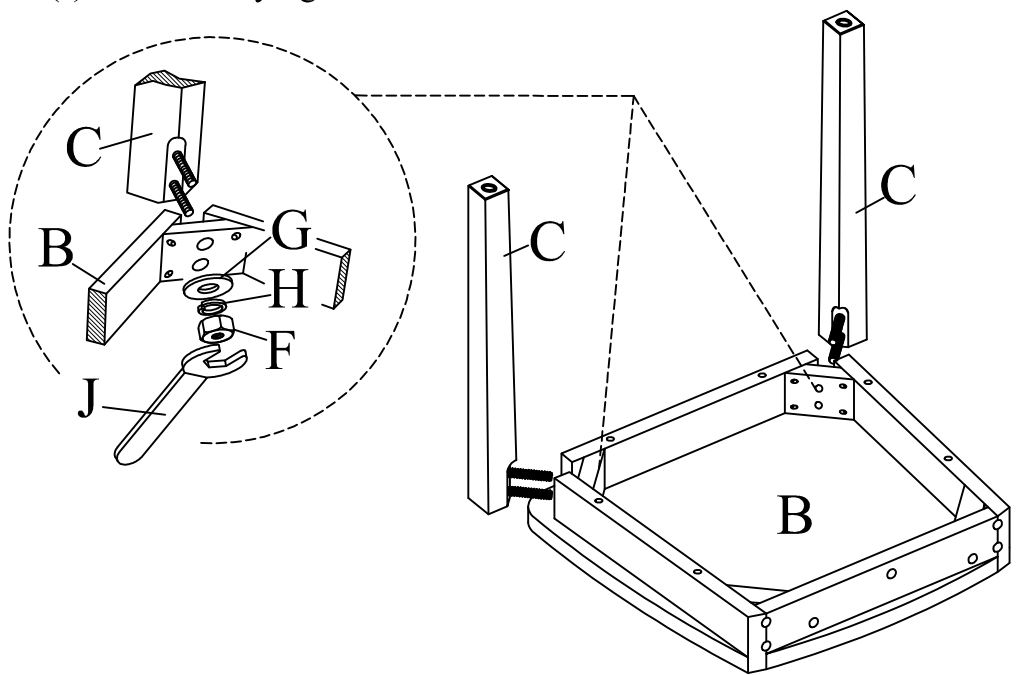

Take the Allen Wrench, and turn the bolts until the legs are secure. **DO NOT TIGHTEN COMPLETELY.** Stop when you feel you are adding force to tighten the bolt.

**2** Attach Wooden Seat (B) to Chair Back (A) assembly by securing the Flat Washer (G), Lock Washer (H) and Bolt (D) on corner. Flat Washer (G), Lock Washer (H) and Bolt (E) onto back rail by using Allen Key (I). Hand tighten only at this moment by using Allen Key (I).

Stand chair up on an even surface and check that it is balanced. If there is a slight wobble, apply downward pressure in the corner where a leg is uneven. Keeping pressure in that corner, tighten all bolts. If balanced, apply downward pressure evenly in the center and tighten all bolts. Do not over-tighten beyond hole depth.

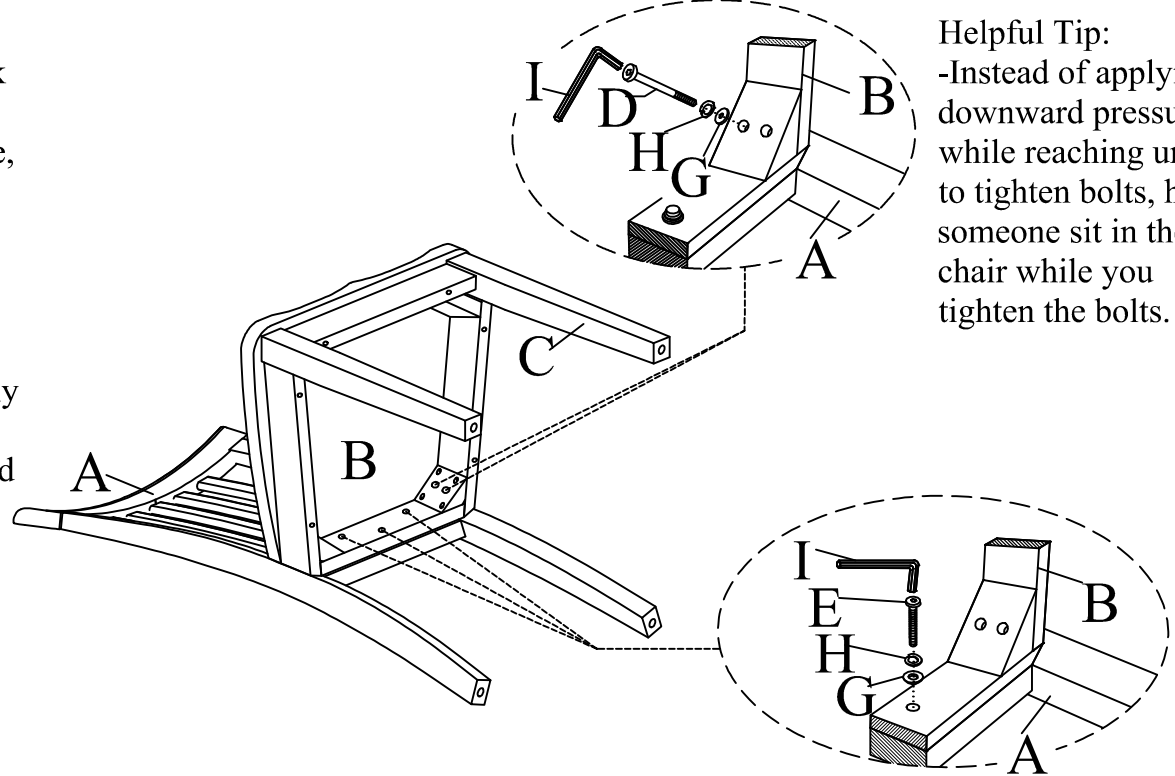

**Helpful Tip:**  
-Instead of applying downward pressure while reaching under to tighten bolts, have someone sit in the chair while you tighten the bolts.

**Cleaning & Care :**  
Treat surface with care. Surface is resistant to scratches but is not scratch resistant. Clean surface with a dry or damp soft cloth. Do not use abrasive cleaners. Hardware may loosen over time. Periodically check that all connections are tight.

# ASSEMBLY INSTRUCTION

## 42" ROUND DINING TABLE

**A** TABLE TOP

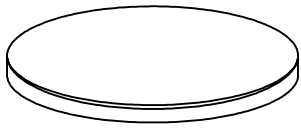

1 pc

**B** PEDESTAL

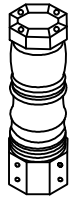

1 pc

**C** MOUNTING PLATE

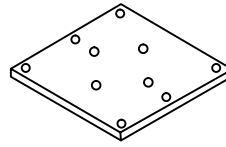

1 pc

**D** LEG WITH LEVELER

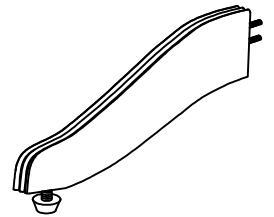

4 pcs

**E** BOLT  
Ø 1/4" x 40 mm



6 pcs

**F** BOLT  
Ø 5/16" x 40 mm



4 pcs

**G** HEX NUT  
Ø 5/16" x 12 mm

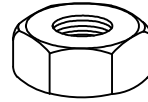

8 pcs

**H** LOCK WASHER  
Ø 5/16" x 13 mm



18 pcs

**I** FLAT WASHER  
Ø 5/16" x 19 mm

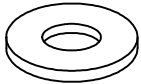

18 pcs

**J** ALLEN KEY  
4 mm



1 pc

**K** WRENCH  
12 mm

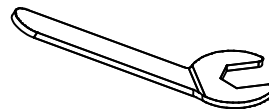

1 pc

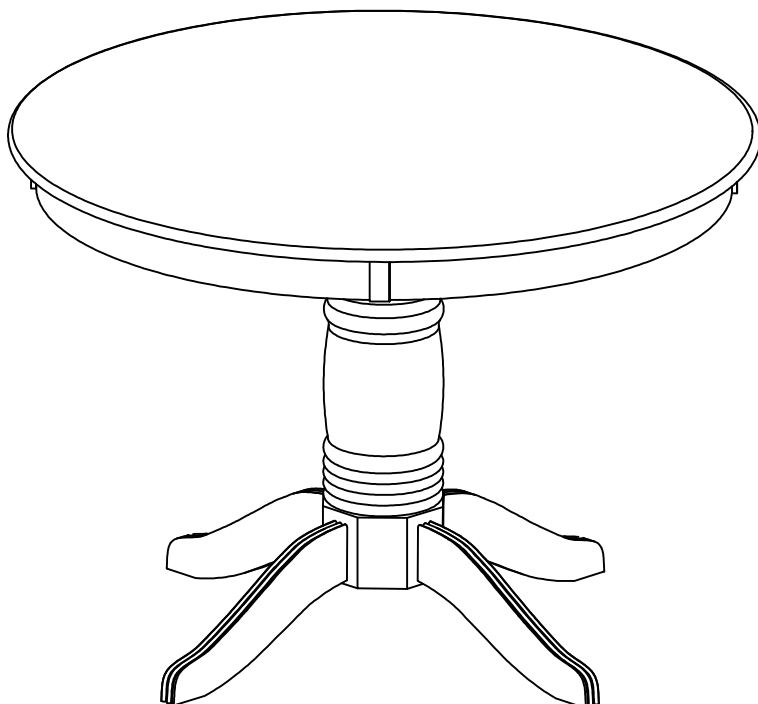

This page lists all the contents included in the box. Please take the time to identify the hardware as well as the individual components to this product. As you unpack and prepare for assembly, place the contents on a carpeted or padded area to protect them from damage.

**1** Attach the Mounting Plate (C) to Pedestal (B) with Flat Washer (I), Lock Washer (H), Bolt (F) and fully tighten with Allen Key (J). Do not over tighten.

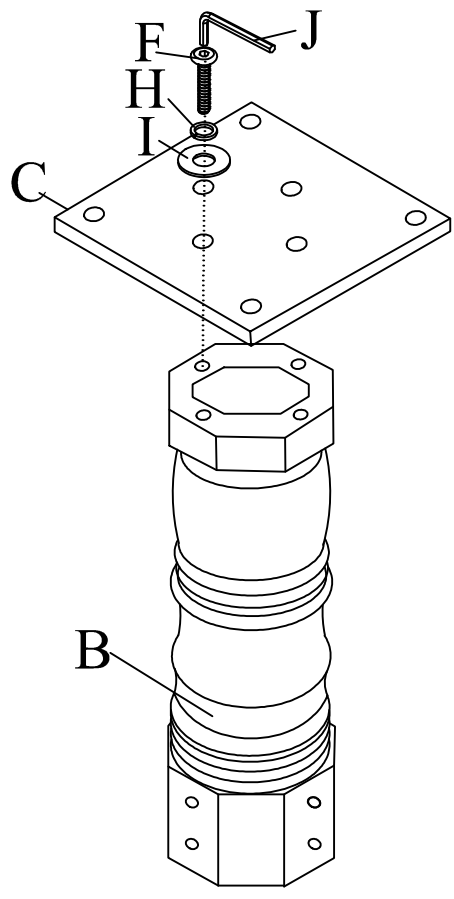

**2** Attach the Mounting Plate (C) to Table Top (A) with Flat Washer (I), Lock Washer (H), Bolt (E) and fully tighten with Allen Key (J). Do not over tighten.

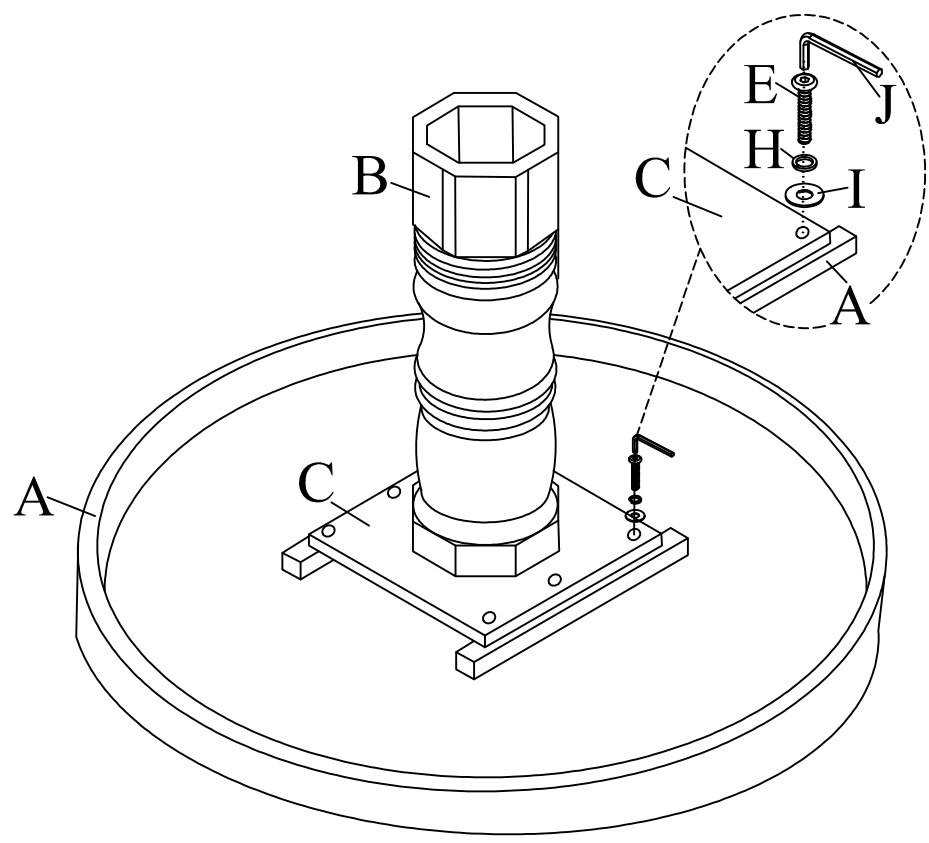

- 3** Attach the Leg With Leveler (D) to Pedestal (B) with Flat Washer (I), Lock Washer (H), Hex Nut (G) and fully tighten with Wrench (K). Do not over tighten.

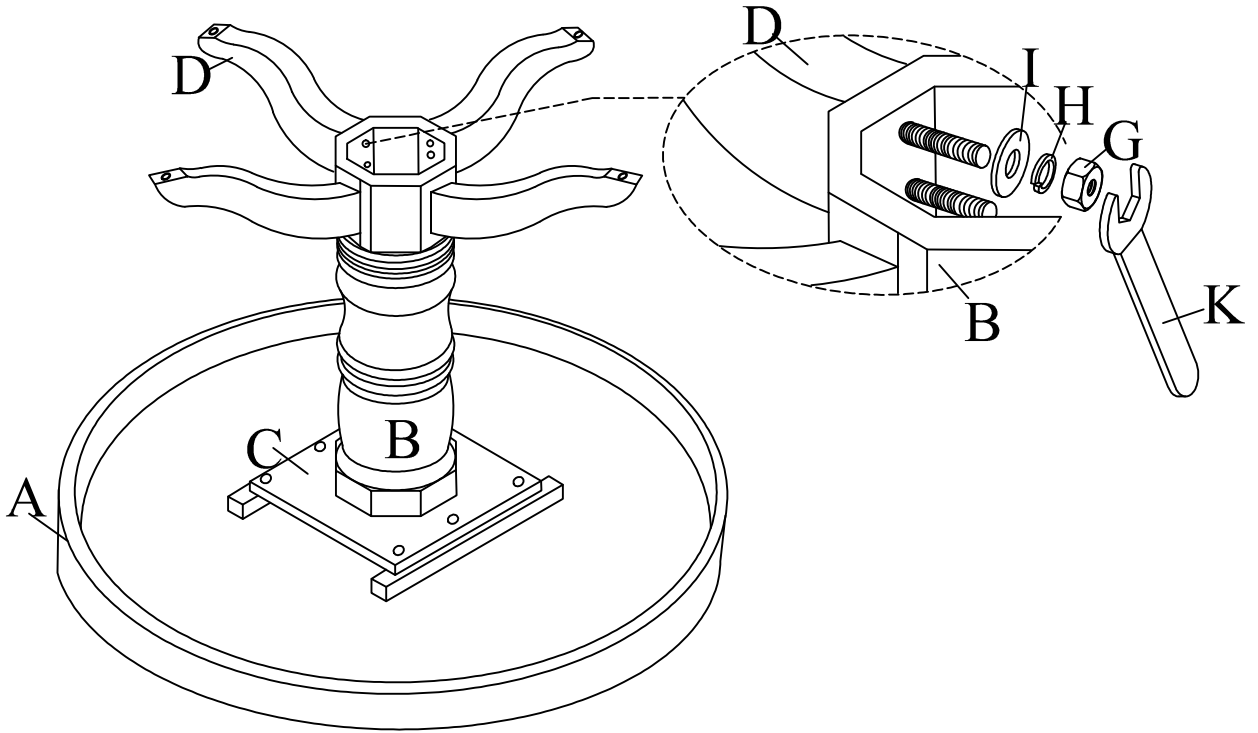

- 4** Turn the Table to upright position, place it on flat surface and adjust the Leveler so that Table is level and does not wobble. Assembly product is now completed.

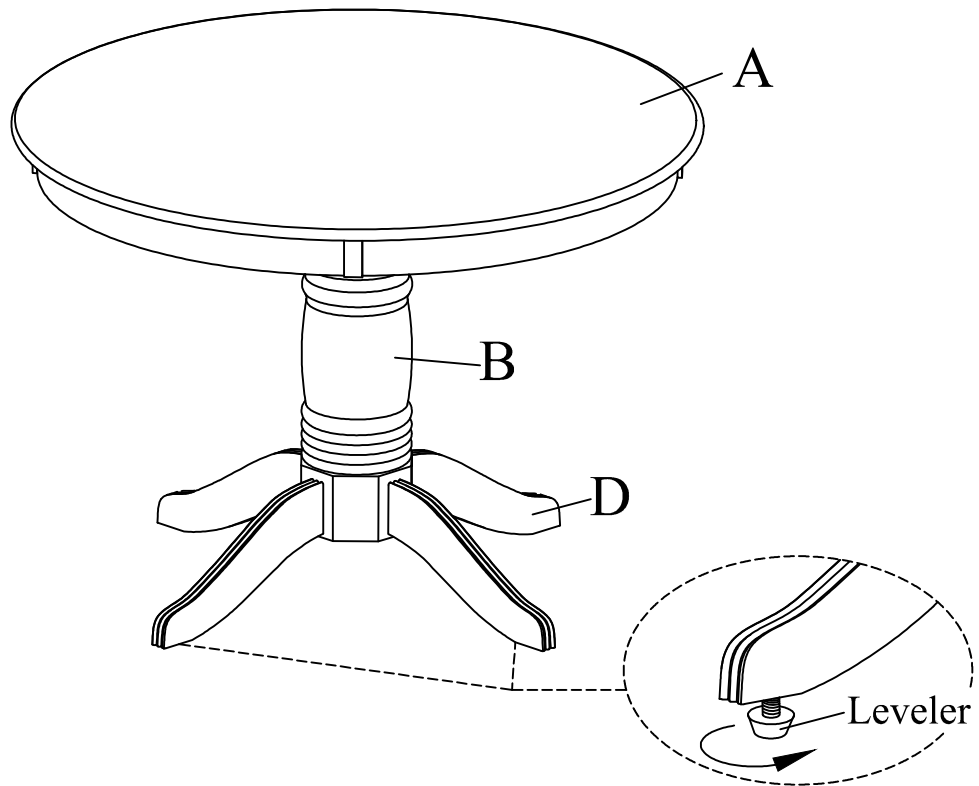

**Cleaning & Care :**

Treat surface with care. Surface is resistant to scratches but is not scratch resistant. Clean surface with a dry or damp soft cloth. Do not use abrasive cleaners. Hardware may loosen over time. Periodically check that all connections are tight.

# ASSEMBLY INSTRUCTION

## 48" L BENCH

**A** BENCH TOP

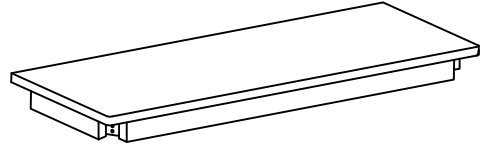

1 pc

**B** BENCH LEG

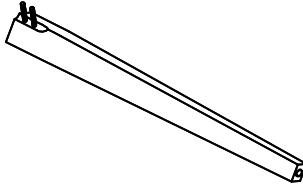

4 pcs

**C** HEX NUT  
Ø 5/16" x 12 mm

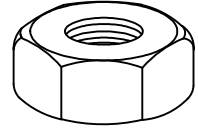

8 pcs

**D** FLAT WASHER  
Ø 5/16" x 19 mm

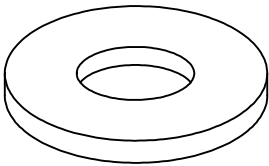

8 pcs

**E** LOCK WASHER  
Ø 5/16" x 13 mm

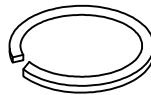

8 pcs

**F** WRENCH  
12 mm

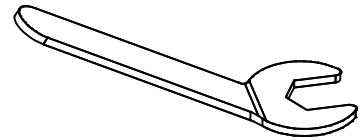

1 pc

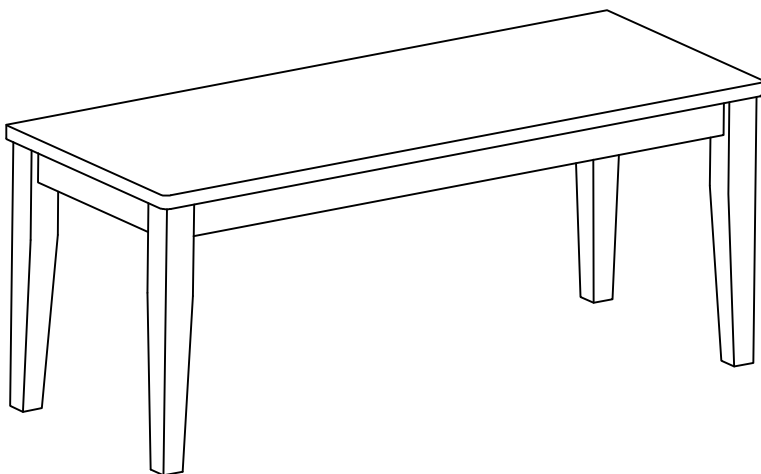

This page lists all the contents included in the box. Please take the time to identify the hardware as well as the individual components to this product. As you unpack and prepare for assembly, place the contents on a carpeted or padded area to protect them from damage.

**1** Place the Bench Top (A) up side down on the floor with a piece of cloth or carpet underneath to prevent from scratching. Attach the Bench Leg (B) to the Bench Top (A) using Flat Washer (D), Lock Washer (E) and Hex Nut (C) by Wrench (F). Do not fully tighten.

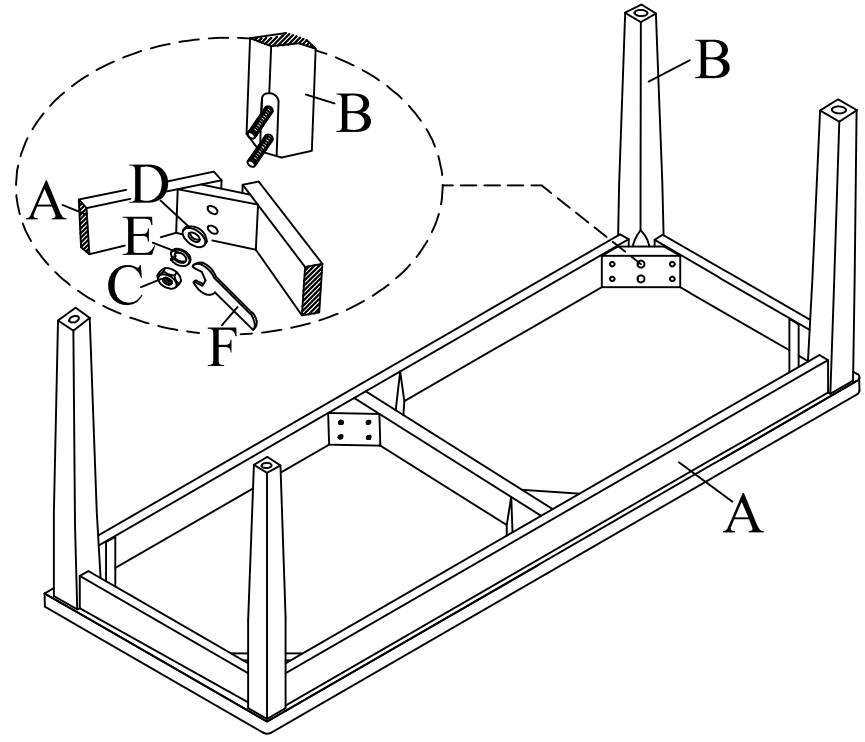

**2** Turn the Bench to upright position, place it on flat surface and adjust legs so that Bench is level and does not wobble. Assembly product is now completed .

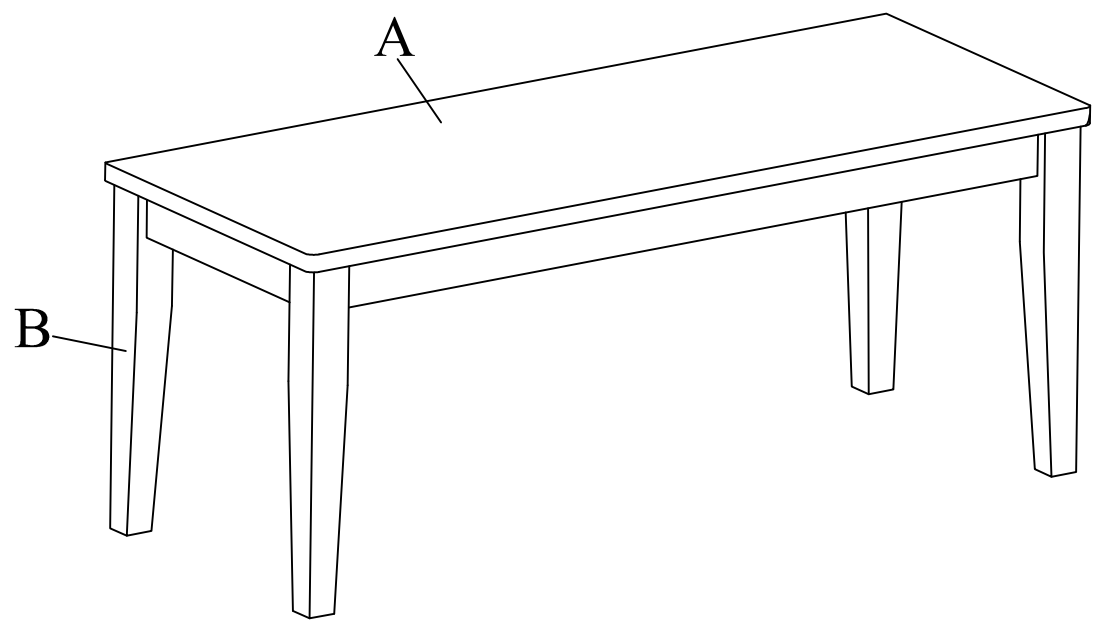

**Cleaning & Care :**  
Treat surface with care. Surface is resistant to scratches but is not scratch resistant. Clean surface with a dry or damp soft cloth. Do not use abrasive cleaners. Hardware may loosen over time. Periodically check that all connections are tight.