













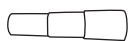

PART Pièce Pieza		Qty. Qte. Ctd.
A		1
B		1
C		2
D		1
E		1
F		1
G		1
H		5
I		1
J		2
K		4
L	 1/4*1-1/2"	4
M	 5/16*1-1/2"	6
N	 5/16*3/4"	3
O	 M8*20mm	4
P		1



ATTENTION / ATTENTION / ATENCION

Make sure all bolts and screws are fully tightened before using chair. Lubricate all moving parts and tighten all bolts/screws every 6 month or whenever needed.

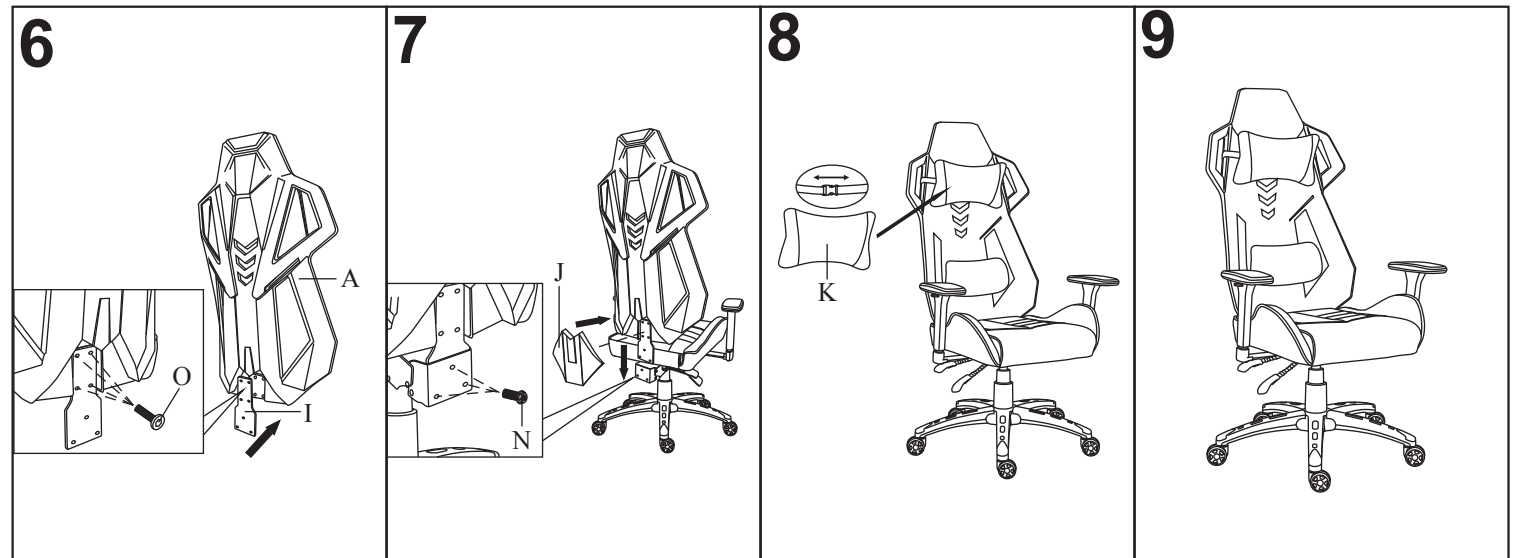
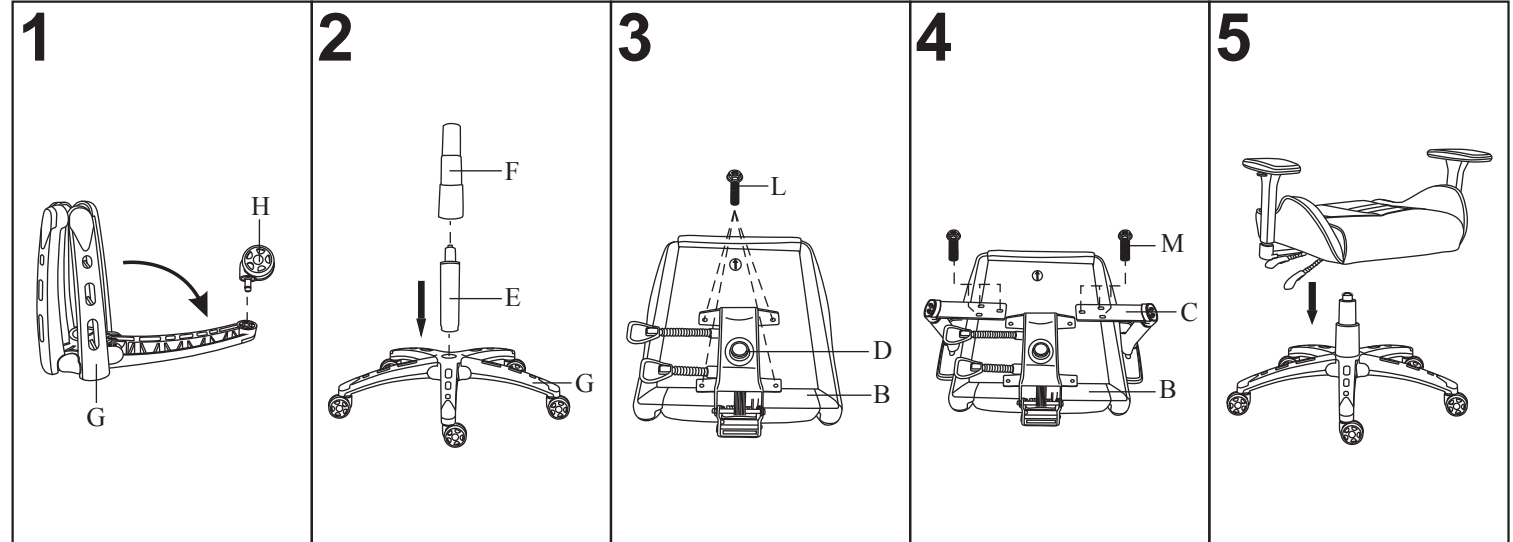
S'assurer que tous les boulons et vis sont serrés à fond avant d'utiliser la chaise. Lubrifier toutes les pièces mobiles et serrer tous les boulons/vis tous les 6 mois ou selon le besoin.

Asegúrese que todos los pernos y tornillos estén completamente apretados antes de usar la silla. Lubrique todas las piezas móviles y apriete todos los pernos/tornillos cada 6 meses o como sea necesario.

▲WARNING / AVERTISSEMENT / ADVERTENCIA

To ensure proper assembly, follow all steps and use all parts. Failure to follow this warning can result in serious injury to yourself or others.

Effectuer toutes les opérations et utiliser toutes les pièces pour être sûr que l'assemblage est correct. L'observation de cet avertissement peut entraîner des blessures graves pour soi ou pour les autres.

Para asegurar un armado correcto, siga todos los pasos indicados y utilice todas las piezas. Si no se observa esta advertencia, se pueden causar lesiones graves a su persona o a los demás.

RSP-200

BACK TILT

Lift the lever to adjust the angle of the back. Release the lever to lock the back angle.

INCLINACIÓN POSTERIOR

Levante la palanca para ajustar el ángulo de la parte posterior. Suelte la palanca para bloquear el ángulo posterior.

INCLINAISON ARRIÈRE

Soulevez le levier pour régler l'angle de l'arrière. Relâchez le levier pour verrouiller l'angle arrière.

SEAT HEIGHT

Lift this lever to adjust the seat height. Release the lever to lock the seat height.

Pull lever outwards to allow the chair to recline. Push lever inwards to lock in the upright position.

ALTURA DE ASIENT

Levante la palanca para ajustar la altura del asiento. Suelte la palanca para trabar la altura del asiento.

Tirez le levier vers l'extérieur pour permettre inclinaison. Poussez le levier pour verrouiller en position verticale.

HAUTEUR DE SELLE

Soulevez ce levier pour régler la hauteur du siège. Relâchez le levier pour verrouiller la hauteur du siège.

Tirar de la palanca hacia el exterior para permitir que la silla reclinable. Empuje hacia dentro la palanca para bloquear en posición vertical.

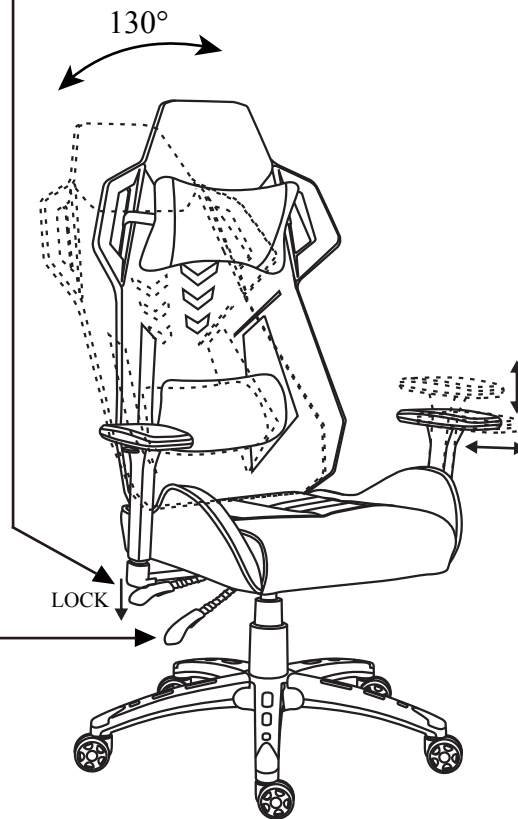

ARM ADJUSTMENT

Raise or lower, go forward or backward to support your forearms.

AJUSTE DEL BRAZO

Levante o baje, avance o retroceda para apoyar sus antebrazos.

AJUSTEMENT ARM

Relevez ou baissez, avancez ou reculez pour supporter vos avant-bras.