



# Schlage **Ascent**

SMART ENTRANCE LEVER

Quick Start Guide

# Parts



## Tools required

- Tape measure
- Pencil
- Level
- Drill
- Drill bit - Ø10mm
- Hole saw - Ø54mm
- Screwdriver (Phillips #2)
- Spade bit - Ø25mm (timber door)
- Hole saw - Ø25mm (metal door)

## Door thickness

- 32mm - 55mm

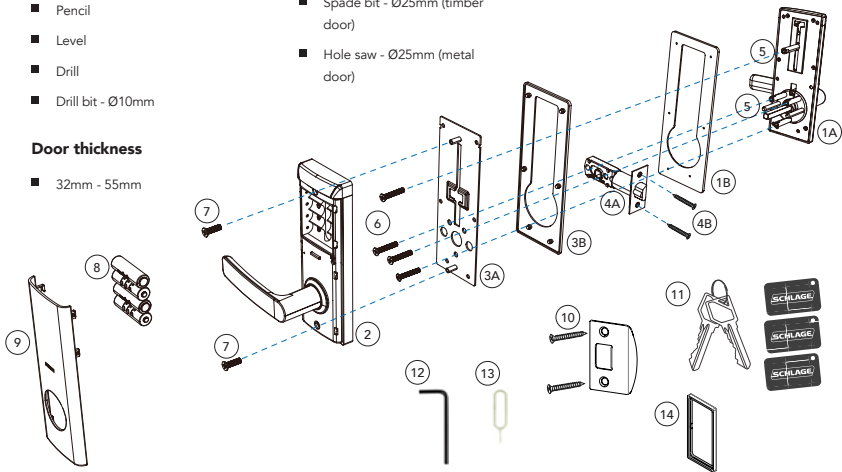

## Components

- 1 A.** External lock body  
**B.** External gasket
- 2.** Internal lock body
- 3. A.** Internal mounting plate  
**B.** Internal gasket
- A.** 60/70mm adjustable deadlatch  
**B.** 2x latch fixing screws
- 4x** Screw standoffs  
**1x** Spindle (7.8x7.8x60)  
**2x** Latch guide posts
- 4x** Mounting plate fixing screws (M5)
- 2x** Internal body fixings (M4)
- 4x** AA alkaline batteries
- 9.** Battery cover
- 10.** Strike plate and fixing screws
- 11.** 2x keys and 3x tags
- 12.** Hex tool for battery compartment
- 13.** Reset pin
- 14.** Latch shroud (use behind latch when installing into an aluminium door)

For more information visit [schlage.co.nz/ascent](http://schlage.co.nz/ascent)

## Fixing pack

Door thickness	Mounting kit	Installation fixings	Deadlatch fixings
32mm - 40mm	4x M5x25mm CSK screw 1x M5xM5x25mm screw standoff with sliding screw 3x M5xM5x25mm screw standoffs	1x 7.8x7.8x60mm square shaft spindle 2x M4x10mm CSK screws 2x M4x32mm latch guide posts 1x M6x12mm replacement handle grub screw 1x Reset pin 1x Hex key 1x Latch shroud	4x M4x20mm CSK screws for wooden door 4x M3.9x16mm CSK screws for aluminium door
41mm - 55mm	4x M5x30mm CSK screw 1x M5xM5x35mm screw standoff with sliding screw 3x M5xM5x35mm screw standoffs		

### External lock body

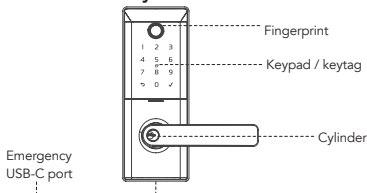

### Internal lock body

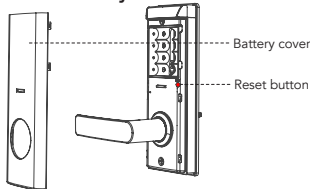

## Installation

### 1. Prepare the door

- Follow the Schlage Ascent smart entrance lever template to prepare your door.
- Latch comes in 60mm backset position. If required, pull latch case to extend to 70mm backset position.
- Mount latch into position.
- Ensure that the spindle hole is square to the door.

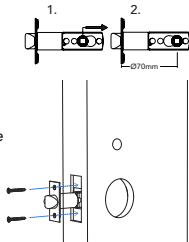

### 2. Prepare jamb and install strike

If jamb preparation is required, we recommend contacting a locksmith for installation.

- Install strike and dust box as provided in box.
- Adjust strike anti-rattle tab to achieve a firmly held and sealed door.

The beveled edge of the latch should face the strike plate so that it will retract automatically.

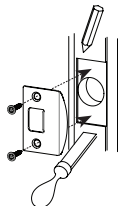

### 3. Handing (as required)

Unfasten retaining grub screw on the external lever and rotate lever 180°. Tighten grub screw.

Unfasten screw located at the back of the internal lock body and rotate lever 180°. Insert screw into opposite hole and tighten.

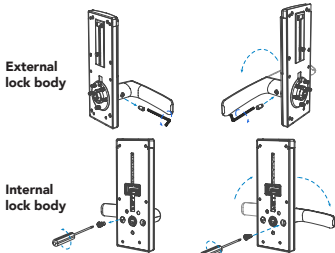

### 4. Assemble fixings

A. Measure door thickness and choose appropriate mounting kit (see label on fixing packs).

#### From 'Installation fixings':

B. Fit the spindle by pressing down the pin and installing as shown.

C. Fit latch guide posts (x2) either side of the spindle and tighten.

#### From 'Mounting kit':

D. Fit screw standoffs (x3) and tighten.

E. Fit screw standoff with sliding screw by aligning flats under screw head with edges of slot.

F. Insert into slot and slide down to position as marked on mounting plate and tighten.

### 4. Assemble fixings cont.

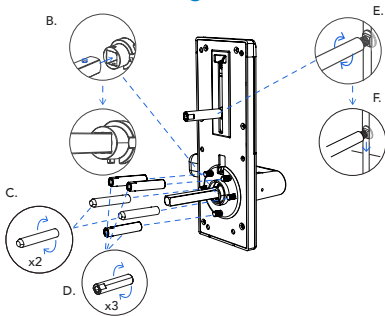

### 5. Position external lock body

A. Ensure the rubber gasket is attached before installation.

B. Position the external body flush against the door, making sure that the cable fits through the door prep hole (as shown) and the spindle and the guide posts go through the latch.

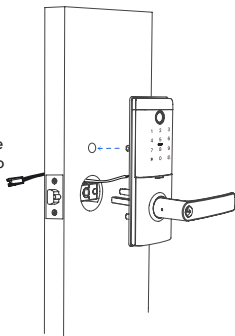

## 6. Position internal lock body

- Ensure the rubber gasket is attached to the mounting plate.
- Install screws from mounting kit through the plate and door and into screw standoffs. Then tighten.
- Remove battery cover from the internal lock body.
- Connect the cable (as shown) ensuring excess is concealed inside the door.
- Align spindle to the spindle hole in the lock body.
- Install the lock body onto the mounting plate, insert screws (as shown) and tighten.

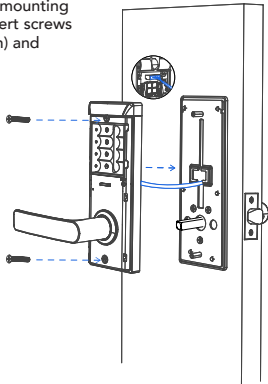
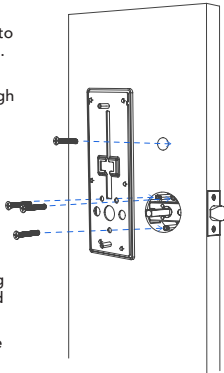

## 7. Install batteries

- Install 4x AA alkaline batteries, ensuring batteries are inserted the correct way.
- Secure the battery cover.

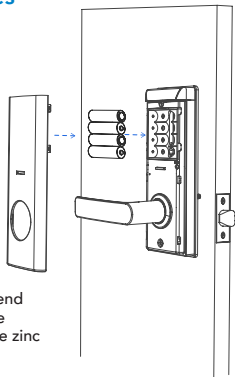

**NOTE:** We recommend using quality alkaline batteries. Do not use zinc carbon batteries.

## 8. Test latch operation

With the door in the open position test lock operation:

- Rotate the external lever, ensure latch **does not** retract.
- Rotate the internal lever, ensure latch **does** retract.

Touch keypad to active keypad and test operation using code 123456✓ (ignore voice prompt during test).

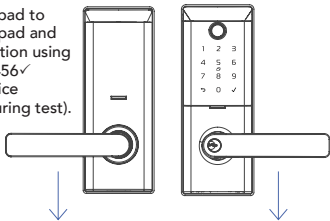

# Pair and programme lock

## Get mobile access with Schlage Breeze

For an enhanced experience and additional functionality, we recommend you download the Schlage Breeze mobile app from the Apple App Store or the Google Play Store.



Apple App Store



Google Play Store

1. Create a user account using your email address (or login if you have an existing account).
2. Ensure Bluetooth is enabled on your phone, tap the keypad of your Schlage Ascent smart entrance lever to activate it.
3. To pair the lock with the app, click on the + and follow the instructions on the app.



# Schlage Breeze app user functions

Within the Schlage Breeze app, users have access to more features than those available on the lock itself. This guide provides information on many of the features available.

## Status of lock

Use the locked and unlocked icons to easily lock or unlock your door, or simply to check the status of the lock (locked or unlocked).



## PIN codes

The Schlage Ascent allows you to store up to 150 PIN codes - either custom, permanent, recurring or scheduled.

Default master PIN code is 123456✓

Master PIN codes must contain 6-11 digits

Custom created codes can contain 4-9 digits

To add a new PIN code, use the Grant Access icon, add PIN code. For a customised PIN code, use the custom feature, add your guest's name, and set your PIN code.

To manage your PIN codes, select Manage Access and update or delete user access as required.

## Virtual keys

When you regularly need to share access to many guests, you can message them PIN code access. This is a great solution for home share properties. Select Grant Access, Invite Breeze User and enter the details for your guest. You can share this virtual key by various options including email or text message.



## Key tags

The Schlage Ascent allows you to store up to 150 key tag credentials. Three key tags are provided with your Schlage Ascent smart entrance lever, additional key tags can be purchased through your local door hardware retailer.

To set up your key tags, select Grant Access, Add Credential, ensure you name your key tag and complete set up of your credential.

To manage your credentials, select Manage Access and update or delete user access as required.

## Auto locking

The Schlage Ascent smart entrance lever default is set with a 5 second auto lock, this can be changed in the Settings, Auto Lock function by selecting a different time delay.



## Passage mode

The lock can be switched to passage mode in the Schlage Breeze app within the Settings function. In this mode, the internal and external lever is unlocked, and you may enter freely. You can either set specific days/times to operate passage mode or disable this feature.

When passage mode is in operation, you may still lock the unit externally by holding the ✓ key for 3 seconds. It will resume passage mode when unlocked via PIN, key tag or key override until the passage mode period completes or the feature is disabled via the Schlage Breeze app.



## Clock

After installation of your lock and registering for the Schlage Breeze app, the clock is automatically set to your local time. The lock has a feature within the Settings function to change to daylight savings, if you use the scheduled PIN code feature, ensure you change to current daylight savings time to ensure the correct time is used by the lock.

## Lock notifications history

To view the audit trail of when the lock was used and by which user, select History. This provides information on your users, timing, or any attempts of adding incorrect PIN codes.



## Lock sound

To enable or disable the lock sound select Settings, Lock Sound. Note, by disabling the sound, both the lock voice prompts and beeps will be disabled.

### Fingerprint access

The Schlage Ascent smart entrance lever allows you to store up to 150 fingerprints.

To set up your fingerprint access, select Grant Access, Add Fingerprint, ensure you name your fingerprint and complete set up.

Your Schlage Ascent smart entrance lever will then prompt you with directions on how to add your fingerprint.

To manage your fingerprint access, select Manage Access and update or delete user access as required.

## Manual programming

### Note for installer

#### Administrator code set up

Once the lock is installed on the door, the lock requires the default admin code to be changed. Refer to manual lock operation on page 8 to change the default admin code and set new PIN code/s.

Once PIN code/s are set, the lock voice command will no longer prompt for the lock to be paired to a mobile device.

#### Note

If the lock is connected to the homeowners Schlage Breeze mobile app, then this step is not required.

## IMPORTANT: Note for homeowner

### Manual factory reset

If your lock was installed by someone other than yourself, we highly recommend you complete a factory reset on the lock to ensure all previously set PIN codes are successfully deleted.

1. Remove the battery cover and using a pointed object, press the reset button for 4 seconds (refer below or to page 2 for the location of the reset button).
2. The lock will prompt to enter a setup code. At this point enter 000✓ on the keypad.
3. The lock will prompt that the reset procedure is complete.
4. The lock is now available to be paired with a mobile device using the Schlage Breeze app.

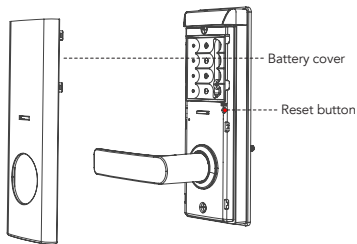



# Manual lock operation

Follow this simple chart if you are manually programming your lock.

Further lock functions are available using the Schlage Breeze app, refer to pages 5-7 for more information.

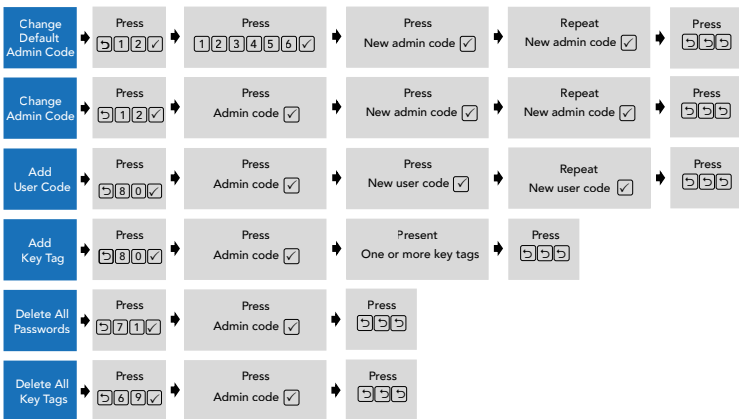

## Hardware specifications

Item	Specifications	Notes
<b>External and internal assemblies</b>	199mm (L) x 76mm (W) x 74mm (D)	Operation temperature: -20°C to 50°C
<b>Battery</b>	AA alkaline battery x 4 (Operation voltage: 4.8 to 6V)	Lasts 6-12 months depending on usage 6 months with Schlage Wi-Fi Bridge (BZ100)

# Schlage Ascent smart entrance lever functions

Refer to the manual lock operation on page 8 for further instructions on manually programming your lock.

## Tips

- To activate and illuminate the keypad, press the ✓ key.
- Always press the ✓ key after entering your PIN code.

## Random PIN code

This security feature allows a user to randomly enter digits before and/or after the PIN code to prevent the user PIN code from being exposed.

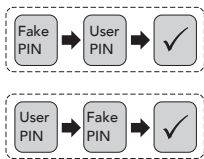

## Tamper alert

The Schlage Ascent smart entrance lever allows for four attempts to correctly input your code, on the fifth incorrect entry the lock alarm will sound. The alarm sounds for 30 seconds, during this time you cannot continue to enter PIN codes. You can however unlock the lock through the Schlage Breeze app which will also turn the lock alarm sound off.

## Low battery notification

The keypad flashes to notify you when the battery is low, with a voice prompt saying, 'Battery low please replace'. Also, while in the Schlage Breeze app, the app will display a low battery notification.

## Emergency power

If your Schlage Ascent smart entrance lever is locked and you require emergency battery power, located on the bottom of the external lock body is a USB-C port. Using a USB-C cable and charged power bank, you can power the lock to regain access as required.

## Warranty conditions

The Schlage Ascent provides a 2 year mechanical and electronic warranty.

Our goods come with guarantees that cannot be excluded under the local consumer law. You are entitled to have the goods repaired or replaced if the goods fail to be of acceptable quality and the failure does not amount to a major failure.

The warranty does not cover any defect or damage which may be caused or partly caused if the goods are not properly maintained, installed or are not suitable to the specified application.

Refer to our website for our finish warranty [www.allegion.co.nz/finisheswarranty](http://www.allegion.co.nz/finisheswarranty).

## Factory default settings

Settings	Factory default
Master PIN code	123456✓
Beeper	Enabled
Wrong code entry limit	5 times
Bluetooth mode	Enabled

Refer to page 7 for instructions on how to complete a factory reset if required.

## Schlage Wi-Fi Bridge (BZ100)

Empower your Schlage Ascent smart entrance lever with Wi-Fi capability. The Schlage Wi-Fi Bridge (BZ100) pairs to your Schlage Ascent smart entrance lever, to provide you with a real-time connection through your smartphone.

Ask your retailer about the Schlage Wi-Fi Bridge (BZ100), sold separately.



## Care and maintenance

### Door furniture

At six (6) monthly intervals, the fixing screws securing the furniture to the door, both surface fix and through fix, should be checked and tightened as required. Loose fitting furniture which fails will not be covered under warranty.

All door furniture should only be wiped clean with a soft damp cloth. A non-abrasive mild household detergent may be used to remove ingrained grime.

### Latch

Care should be taken to ensure the internal components are kept free of dirt and filings during installation as this is the most common cause of malfunction and will not be covered under warranty.



For more information visit  
[schlage.co.nz/ascent](https://www.schlage.co.nz/ascent)

Australia  
1800 098 094  
[info.au@allegion.com](mailto:info.au@allegion.com)  
[www.allegion.com.au](https://www.allegion.com.au)

New Zealand  
0800 477 869  
[nzinfo@allegion.com](mailto:nzinfo@allegion.com)  
[www.allegion.co.nz](https://www.allegion.co.nz)

© 2024 Allegion



PDSC0059