



# P280214

**RIVERSCAPE PLAYHOUSE  
MAISON DE JEUX RIVERSCAPE  
CASA DE JUEGOS RIVERSCAPE**



**CALL US OR GO ONLINE  
APPELÉZ-NOUS OU ALLEZ EN LIGNE  
LLÁMENOS O VISITE NUESTRO SITIO WEB**

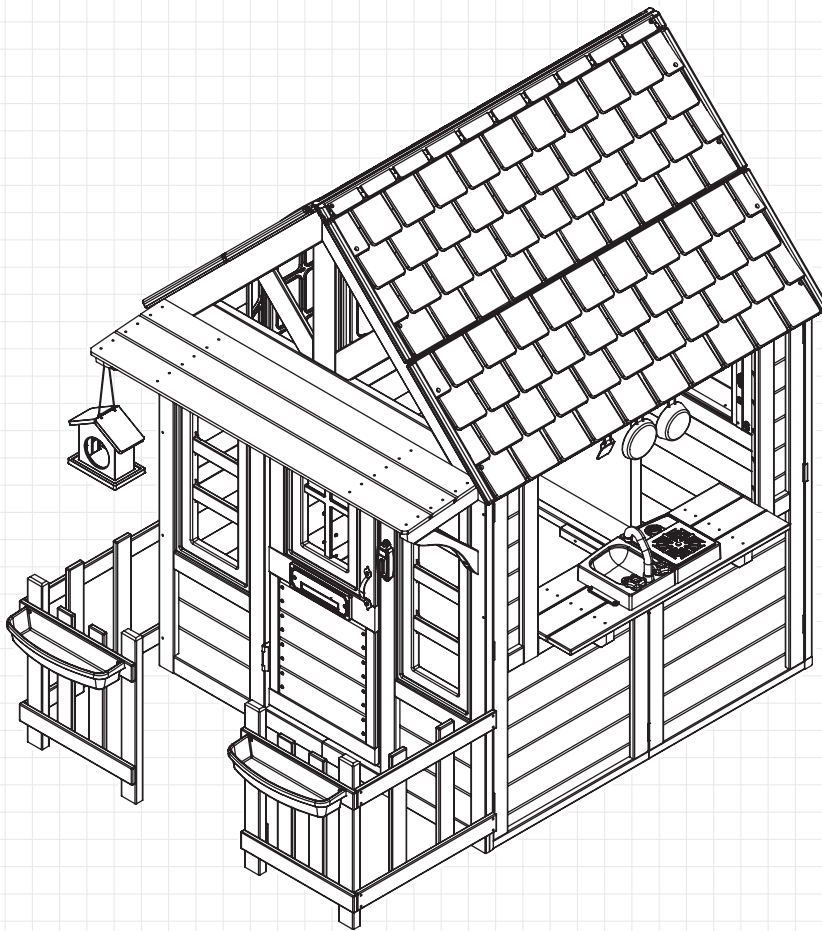

**ASSEMBLY INSTRUCTIONS / INSTRUCTIONS D'ASSEMBLAGE / INSTRUCCIONES DE MONTAJE**

**FOR 24/7 ONLINE PARTS REPLACEMENT / POUR LE  
REPLACEMENT 24/7 DES PIÈCES EN LIGNE / PARA SOLICITUDES  
ONLINE DE PIEZAS DE REPUESTO DE MANERA ININTERRUMPIDA**

**BATCH CODE / CODE DE LOT / CÓDIGO DE LOTE**

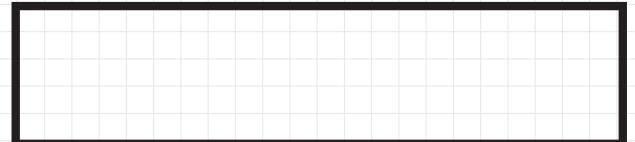

**parts.kidkraft.com**

Backyard Kids, LLC DBA KidKraft  
317 S. Main St.  
Ann Arbor, MI 48104

customerservice@kidkraft.com  
1.800.933.0771  
972.385.0100

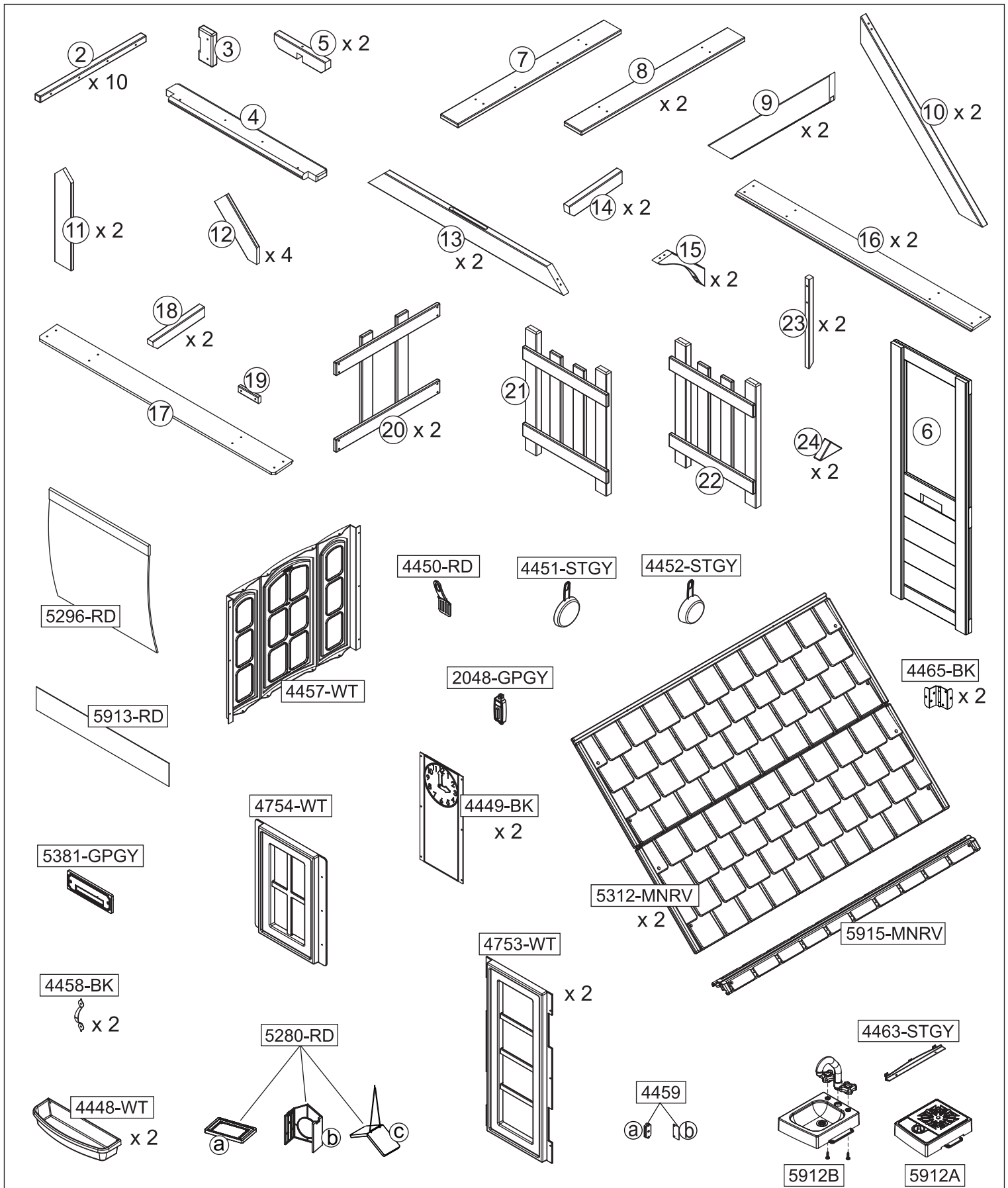

**Parts and Hardware**  
**Pièces et matériel**  
**Partes y Piezas Para Instalación**  
**Teile und Befestigungsmaterial**  
**Parti e componenti meccanici**



**KidKraft**  
MADE FOR MAKE BELIEVE™

parts.kidkraft.com

customerservice@kidkraft.com  
1.800.933.0771  
972.385.0100

If you need to order parts,  
please order below part#

Si necesita pedir piezas, utilice el  
número de pieza indicado a  
continuación para realizar el pedido

Si vous avez besoin de commander  
des pièces, veuillez utiliser le numéro  
de référence ci-dessous.

P-P280214-1A  
P-P280214-1B  
P-P280214-1C  
P-P280214-1D  
P-P280214-1E  
P-P280214-1F  
P-P280214-1G  
P-P280214-1H  
P-P280214-ZZ1  
9323685  
9323687

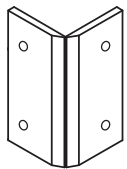
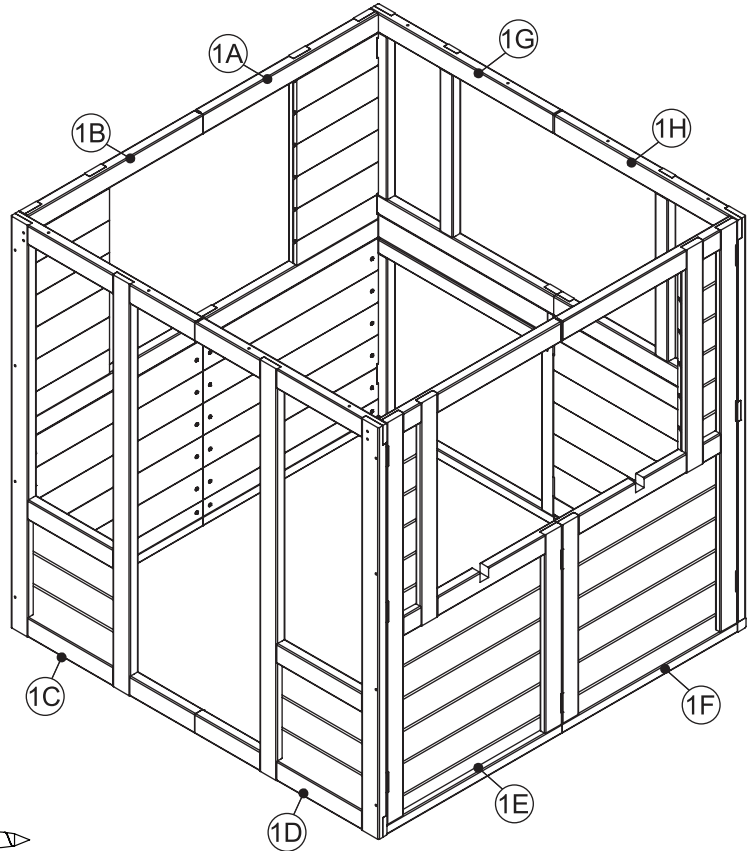



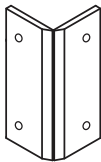





9323687  
(15 Pcs)

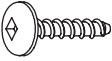

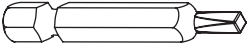
9323685  
(6 Pcs)

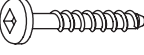

ZZ1  
(84 Pcs)

| <b>A</b>  | <b>x 25</b> | <b>D</b>  | <b>x 9</b>  | <b>G</b>   | <b>x 22</b> | <b>x 1</b>  |
|---|-------------|---|-------------|--|-------------|---|
| <br><b>17 mm</b> |             |                  |             | <br><b>37 mm</b> |             |  |
| <b>B</b>  | <b>x 82</b> | <b>E</b>  | <b>x 70</b> | <b>H</b>   | <b>x 6</b>  |   |
| <br><b>16 mm</b> |             | <br><b>44 mm</b> |             | <br><b>62 mm</b> |             |   |
| <b>C</b>  | <b>x 46</b> | <b>F</b>  | <b>x 4</b>  | <b>I</b>   | <b>x 14</b> |   |
| <br><b>29 mm</b> |             | <br><b>55 mm</b> |             | <br><b>75 mm</b> |             |   |

Parts and Hardware  
Pièces et matériel  
Partes y Piezas Para Instalación  
Teile und Befestigungsmaterial  
Parti e componenti meccanici

All hardware dimensions are approximate.  
Toutes les dimensions du matériel  
sont approximatives.  
Todas las dimensiones de las herramientas  
son aproximaciones.



parts.kidkraft.com

customerservice@kidkraft.com  
1.800.933.0771  
972.385.0100

1

1 x 1

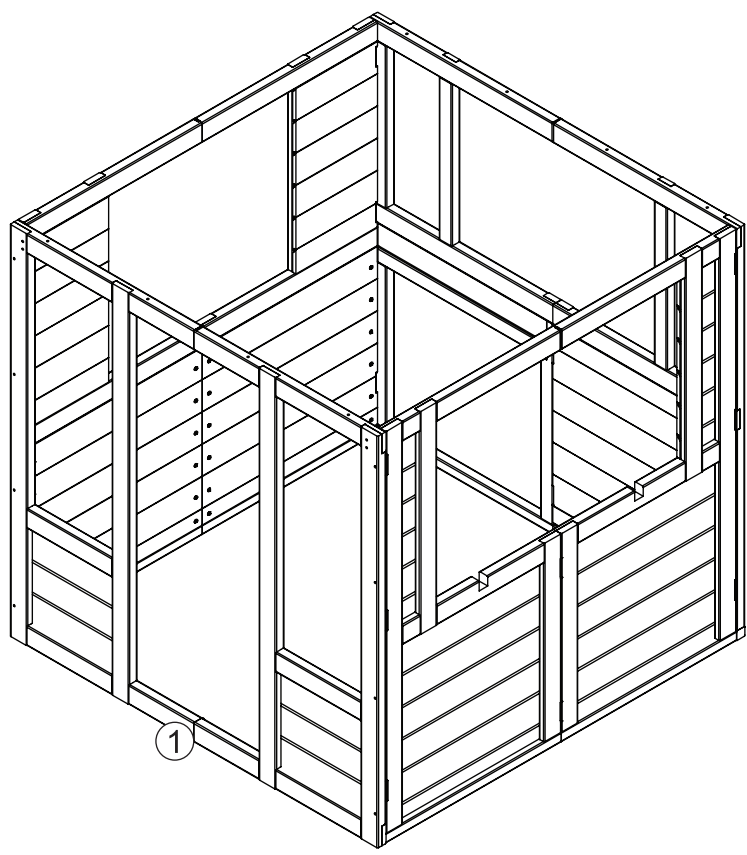
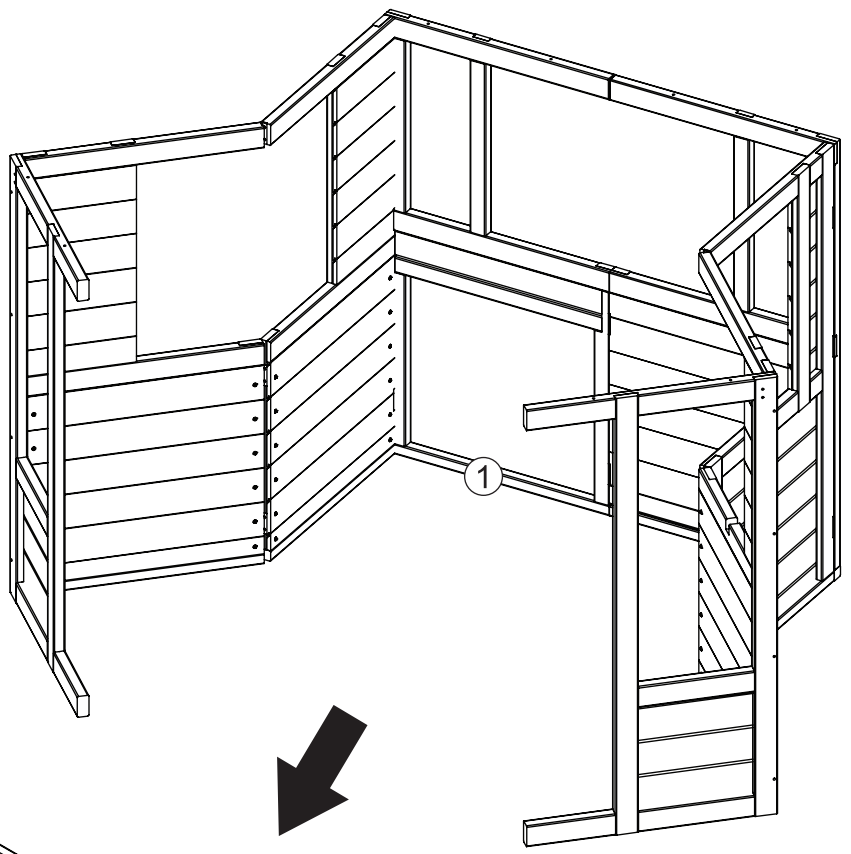
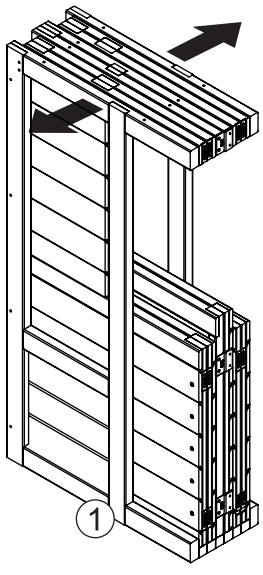

2

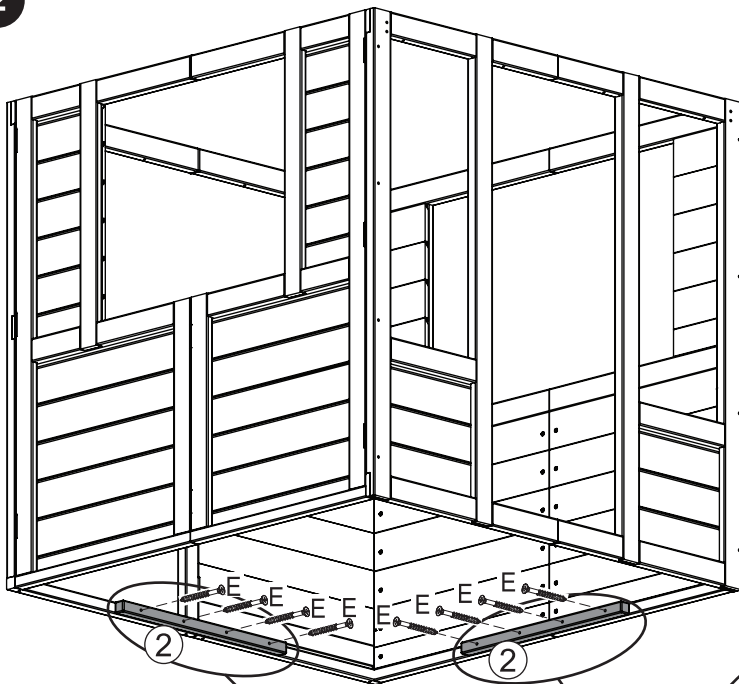

2 x ②

8 x E

Flush  
Aligné  
A ras  
Bündig  
A filo

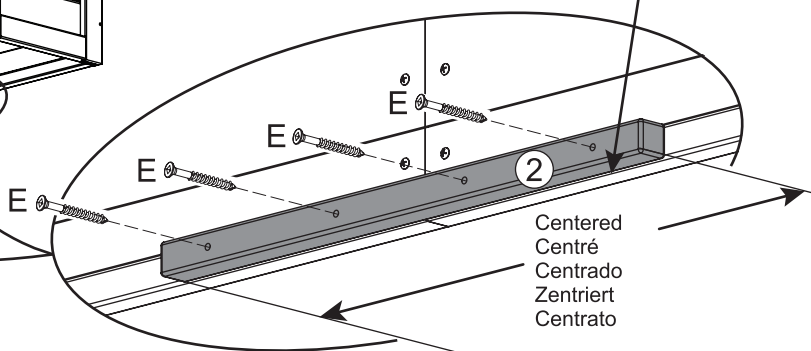

Centered  
Centré  
Centrado  
Zentriert  
Centrato

3

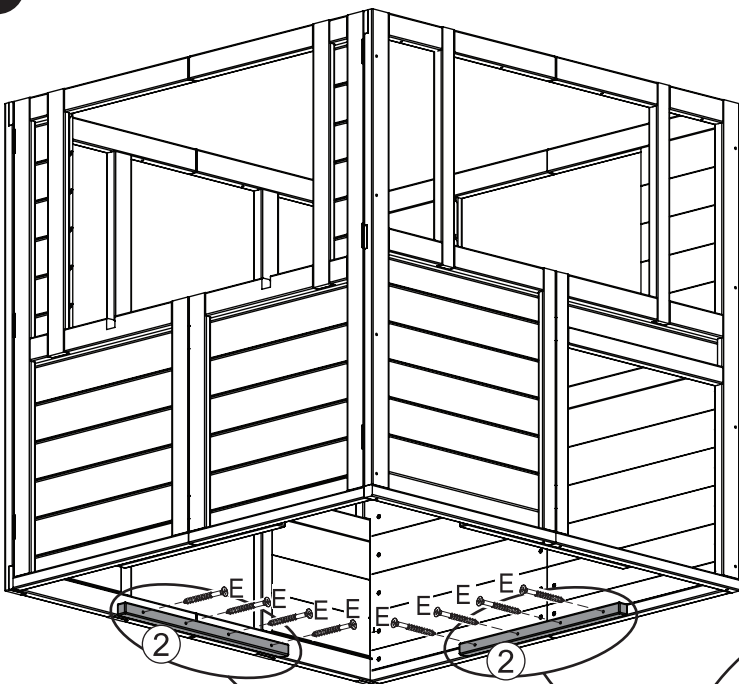

2 x ②

8 x E

Flush  
Aligné  
A ras  
Bündig  
A filo

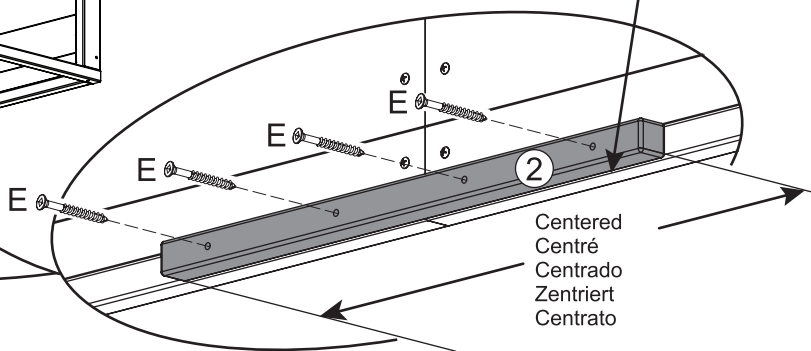

Centered  
Centré  
Centrado  
Zentriert  
Centrato



**KidKraft**  
MADE FOR MAKE BELIEVE™

parts.kidkraft.com

customerservice@kidkraft.com  
1.800.933.0771  
972.385.0100

4

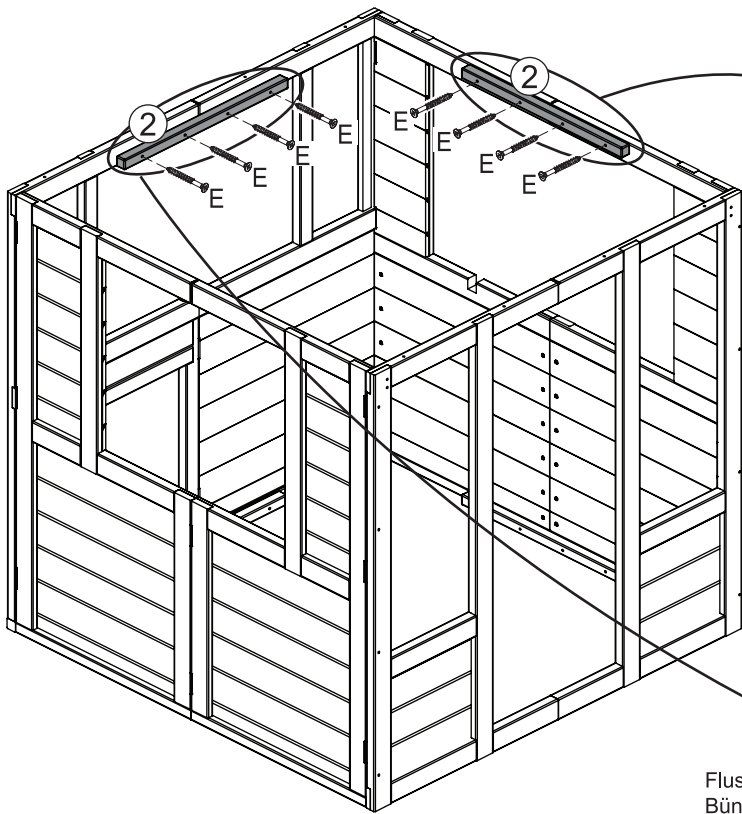

Flush / Aligné / A ras / Bündig / A filo



2 x ②

8 x E

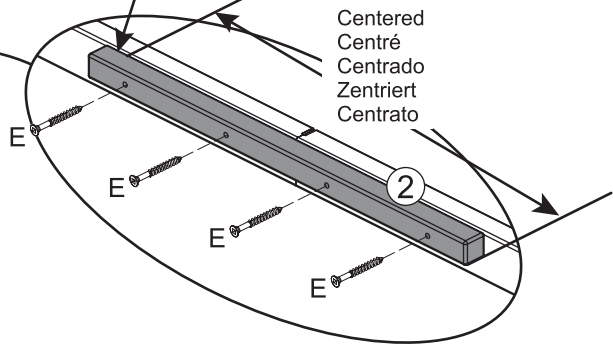

Centered  
Centré  
Centrado  
Zentriert  
Centrato

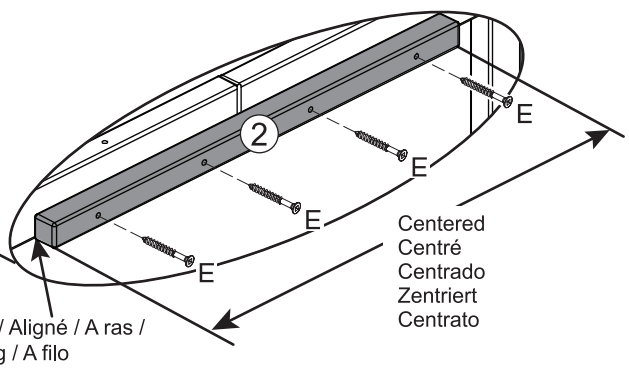

Centered  
Centré  
Centrado  
Zentriert  
Centrato

5

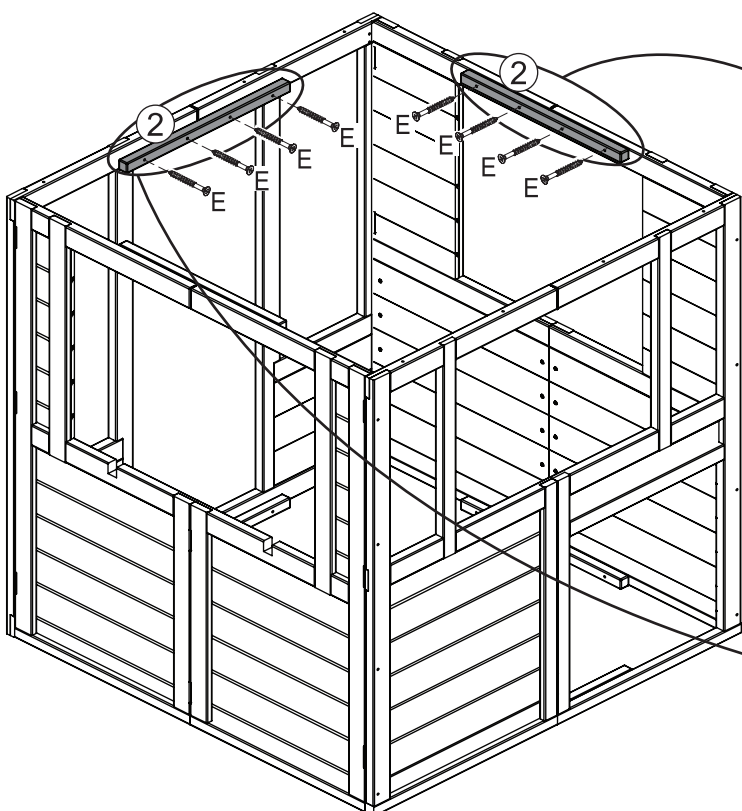

Flush / Aligné / A ras / Bündig / A filo



2 x ②

8 x E

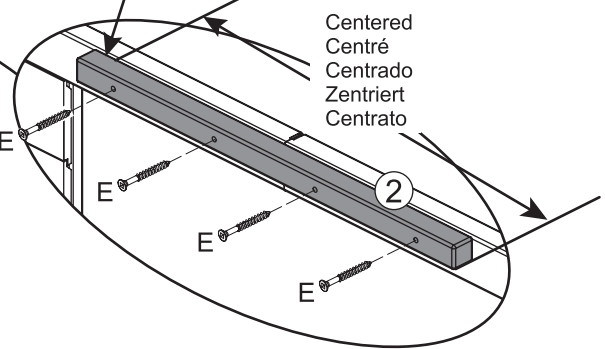

Centered  
Centré  
Centrado  
Zentriert  
Centrato

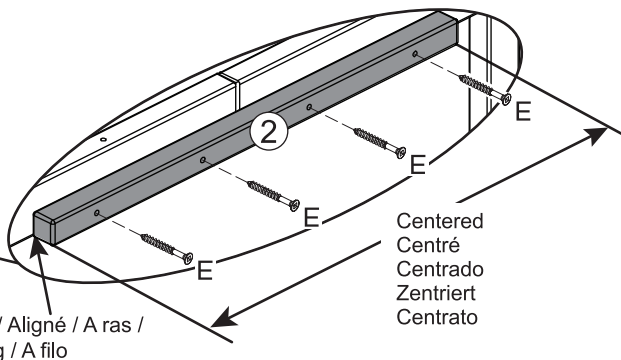

Centered  
Centré  
Centrado  
Zentriert  
Centrato

Flush / Aligné / A ras / Bündig / A filo



parts.kidkraft.com

customerservice@kidkraft.com  
1.800.933.0771  
972.385.0100

6

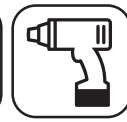

1 x 6

2 x 4465-BK

6 x B

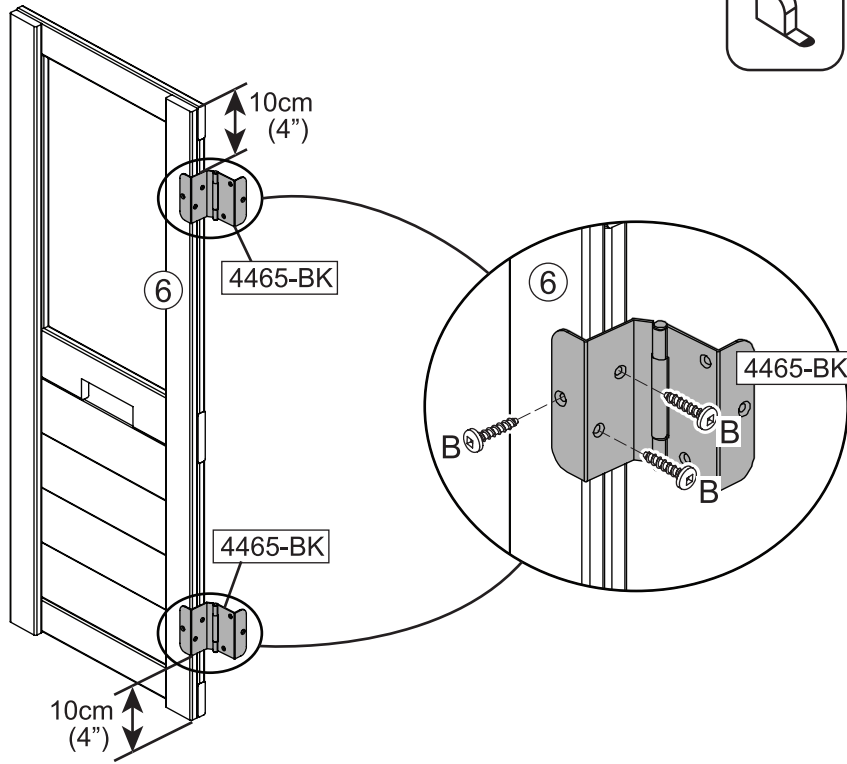

7



6 x B

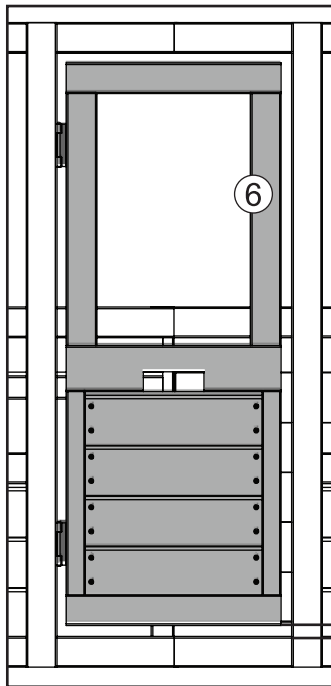
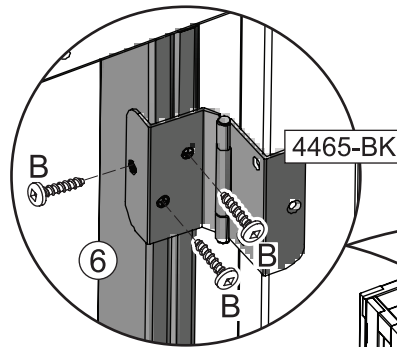

Outside View  
 Vue extérieure  
 Vista exterior  
 Außenansicht  
 Vista dall'esterno

18mm  
 (3/4")

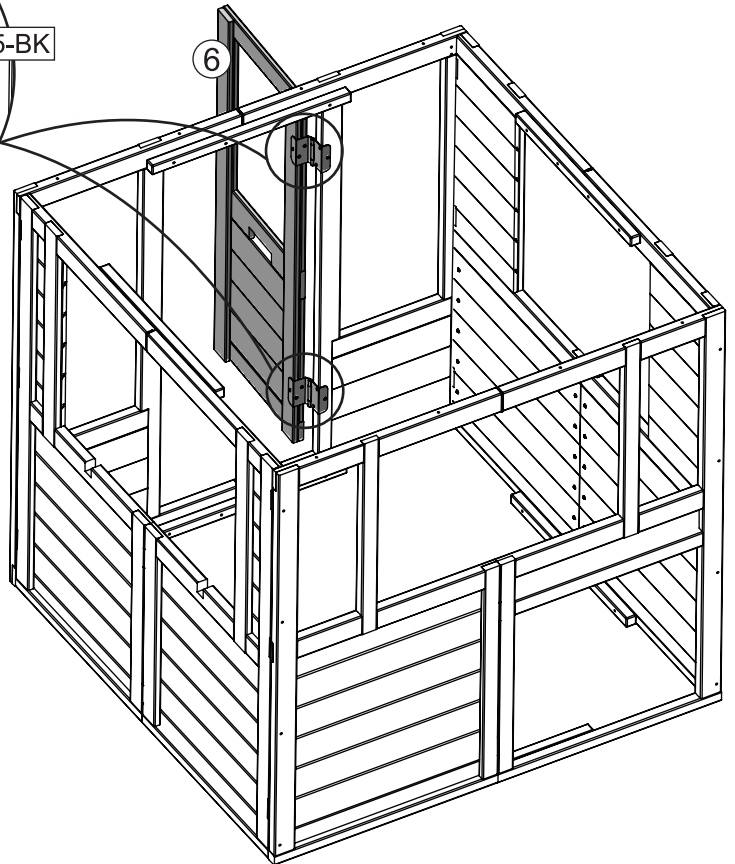

8



8 x E

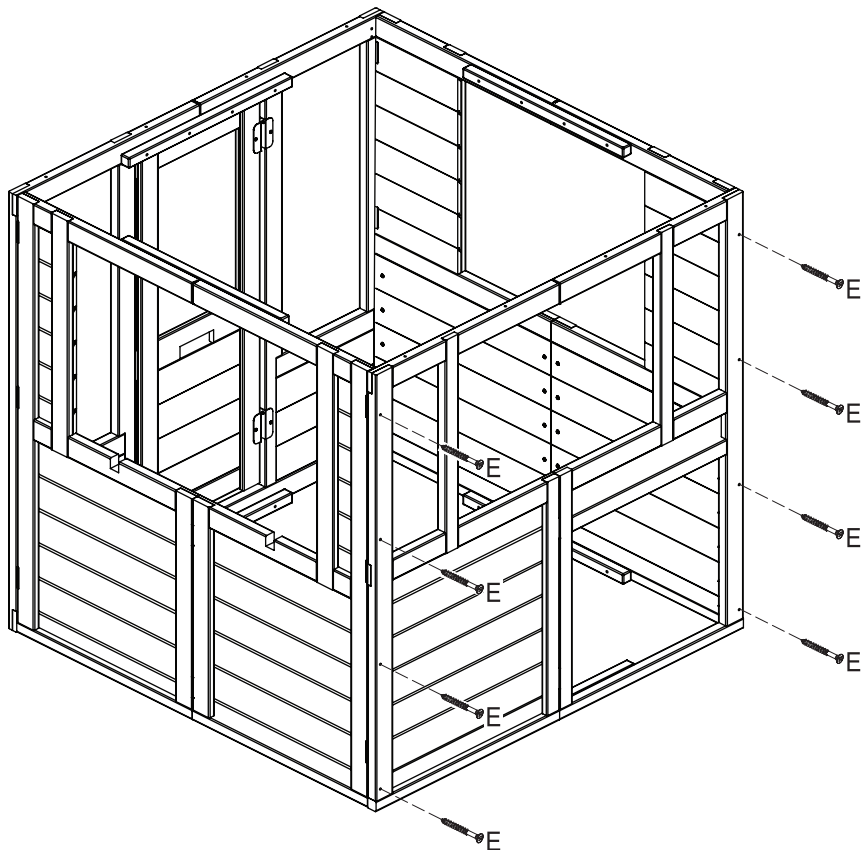

9



8 x E

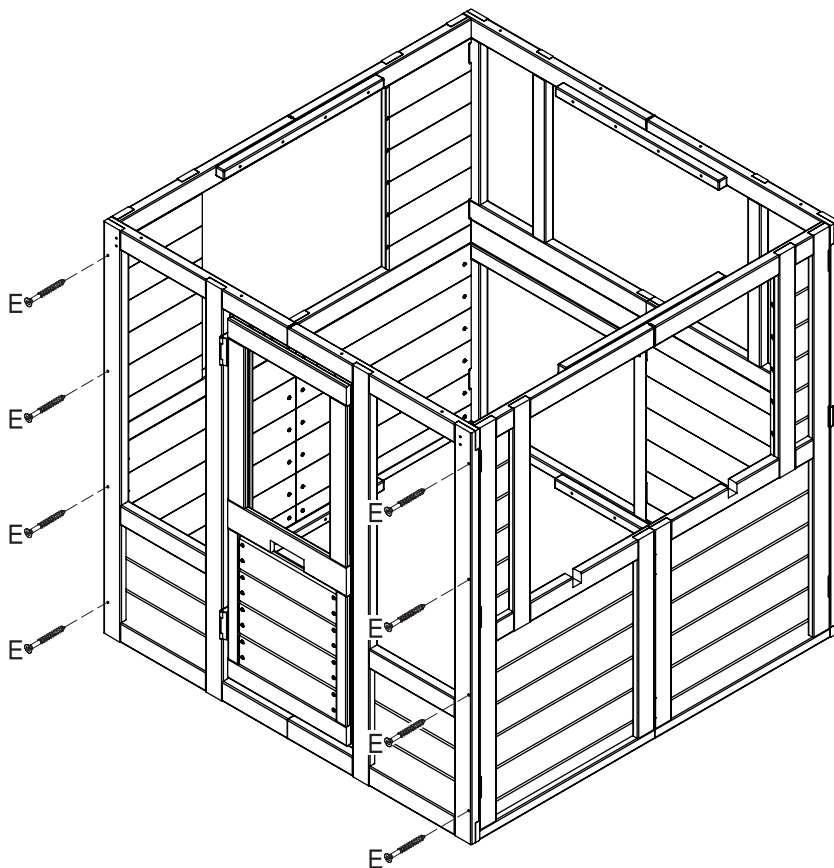

**KidKraft**  
MADE FOR MAKE BELIEVE™

[parts.kidkraft.com](http://parts.kidkraft.com)

[customerservice@kidkraft.com](mailto:customerservice@kidkraft.com)  
1.800.933.0771  
972.385.0100



10

1 x 2048-GPGY

Test the electronics before proceeding with assembly. If you have any issues, please contact customer service.

Tester les pièces électroniques avant de procéder à l'assemblage. Pour tout problème, veuillez contacter le service client.

Prueba los dispositivos electrónicos antes de empezar el montaje. Si tienes algún problema, ponte en contacto con Atención al cliente.

Testen Sie die Elektronik, bevor Sie mit der Montage fortfahren. Kontaktieren Sie bei Problemen bitte den Kundenservice.

Testare le parti elettroniche prima di procedere con il montaggio. In caso di problemi, contattare il servizio clienti.

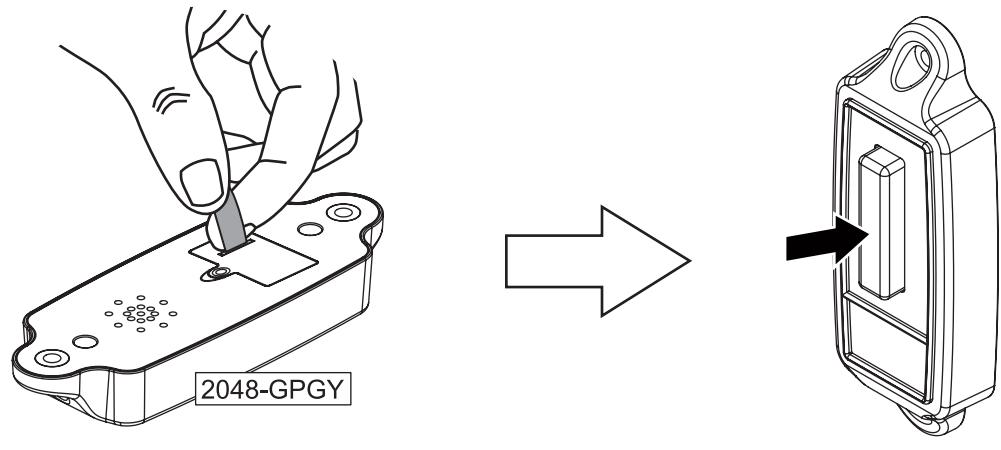

11

2 x B

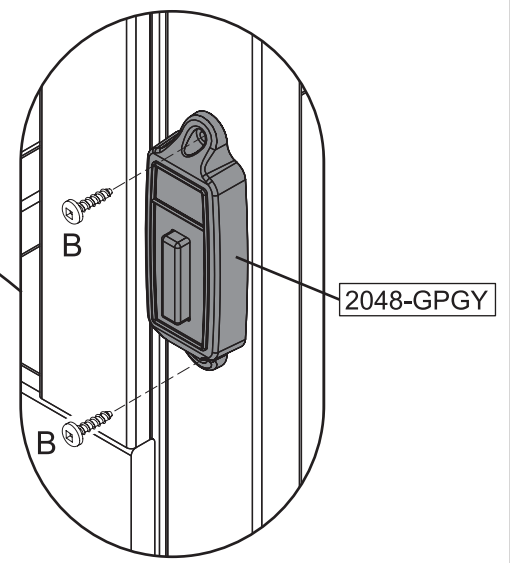
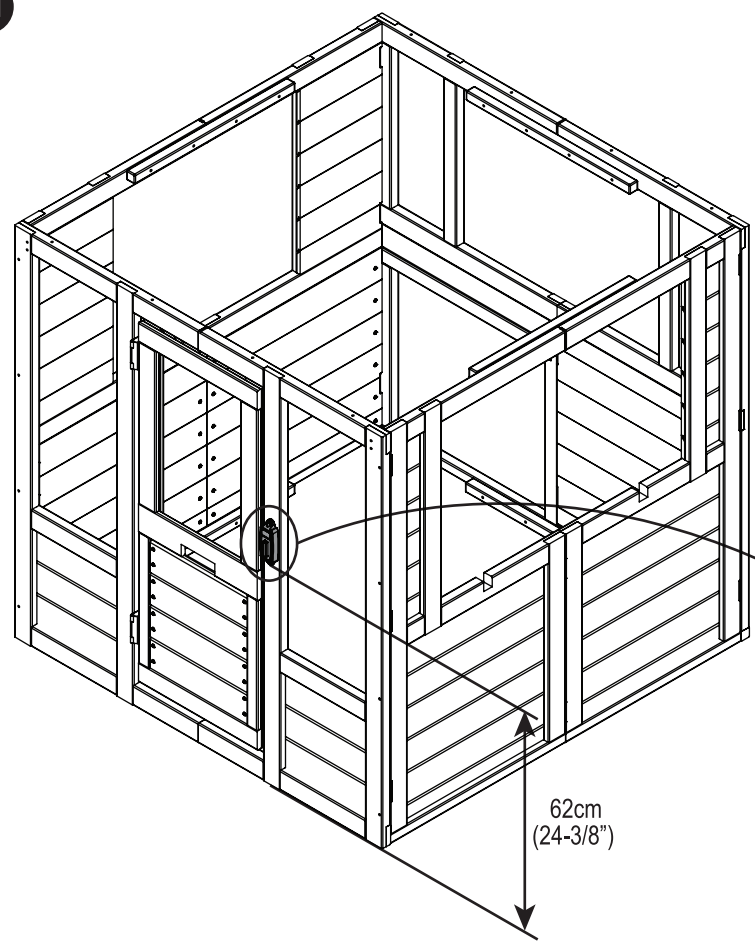
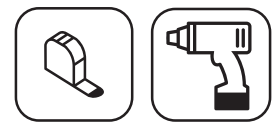

12



1 x 5381-GPGY

2 x B

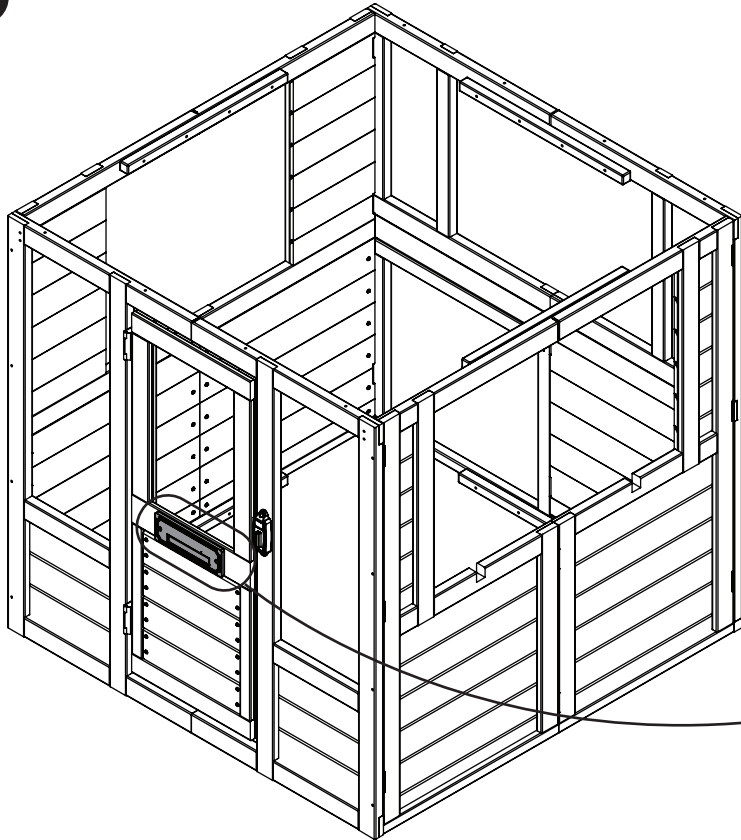

Center horizontally  
Centrer horizontalement  
Centrar horizontal  
Horizontal zentrieren  
Centrare orizzontalmente

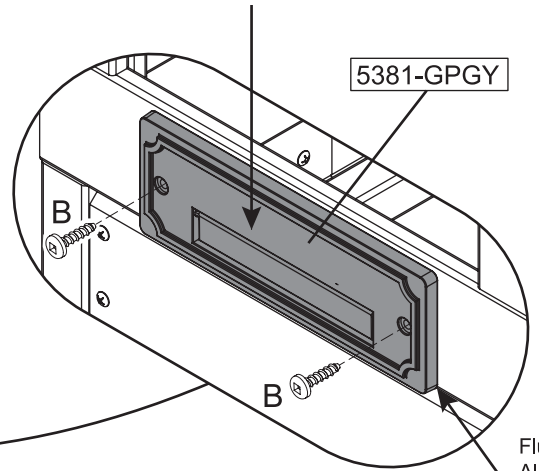

Flush  
Aligné  
A ras  
Bündig  
A filo

13



1 x 4458-BK

2 x B

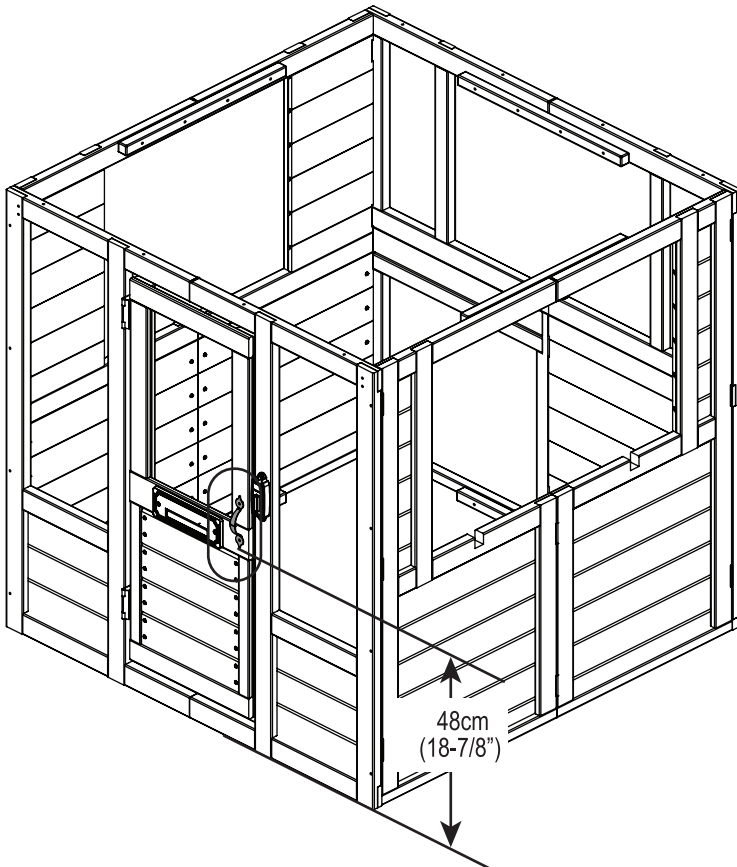

48cm  
(18-7/8")

4458-BK

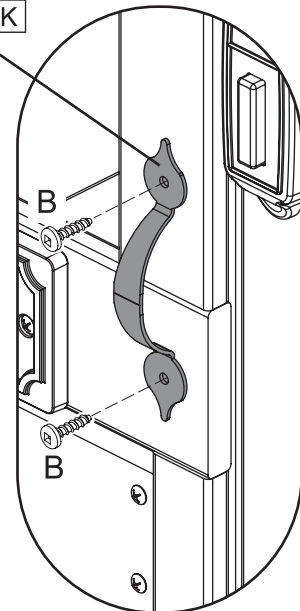

14

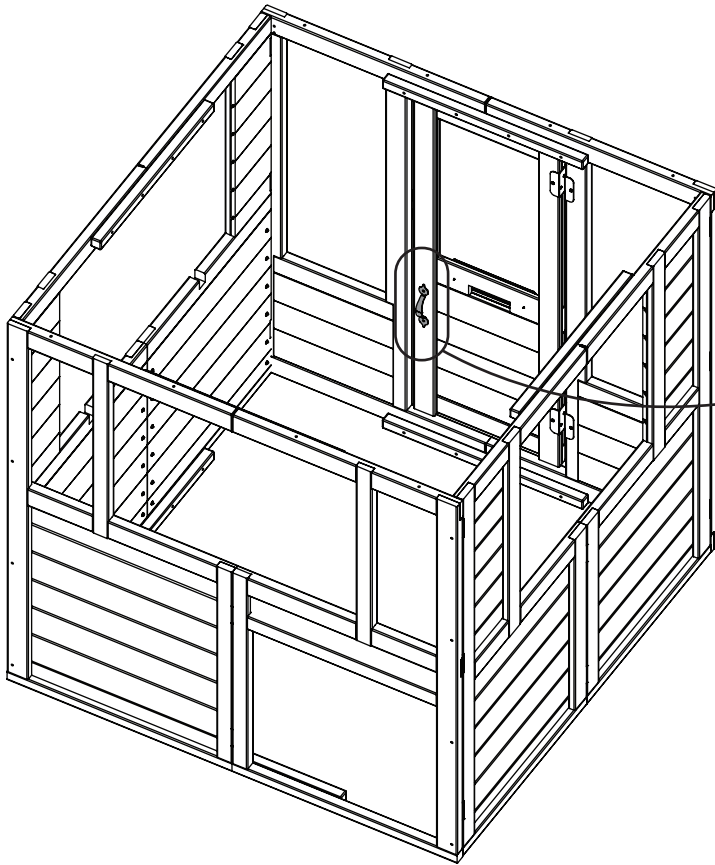

4458-BK

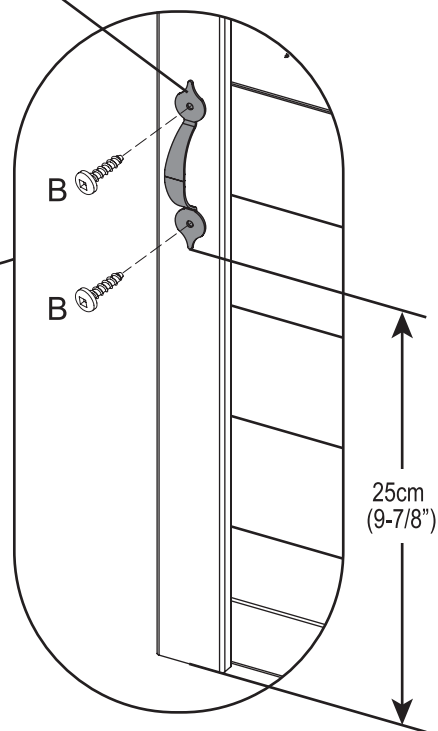

1 x 4458-BK

2 x B



15

Note: 4459-b is flush with door edge  
 Remarque : 4459-b est aligné avec le bord de la porte  
 Nota: 4459-b está a ras del borde de la puerta  
 Hinweis: 4459-b liegt bündig an der Türkante an  
 Nota: 4459-b è a filo del margine della porta



1 x 4459-b

2 x B

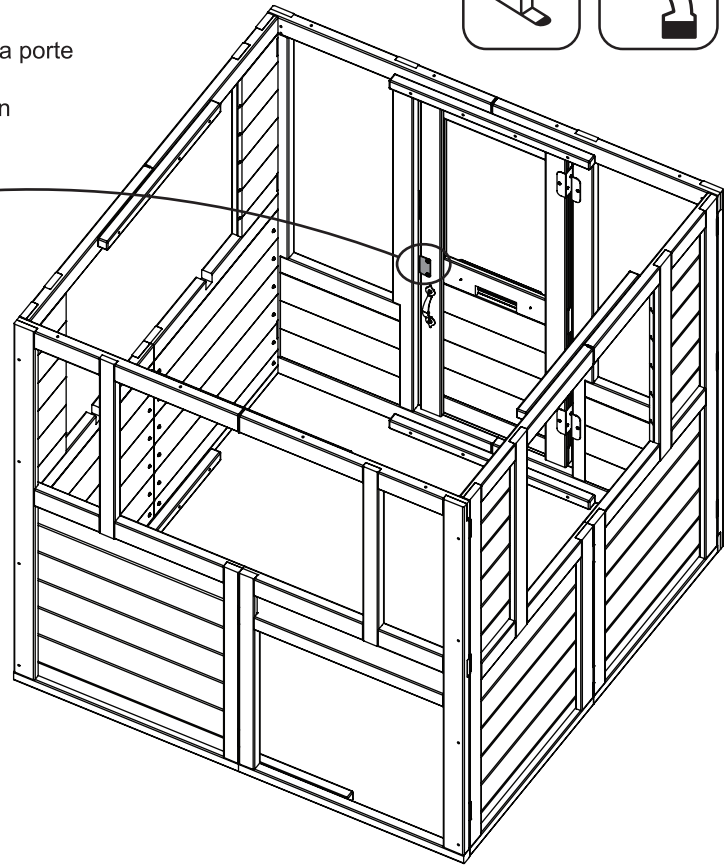
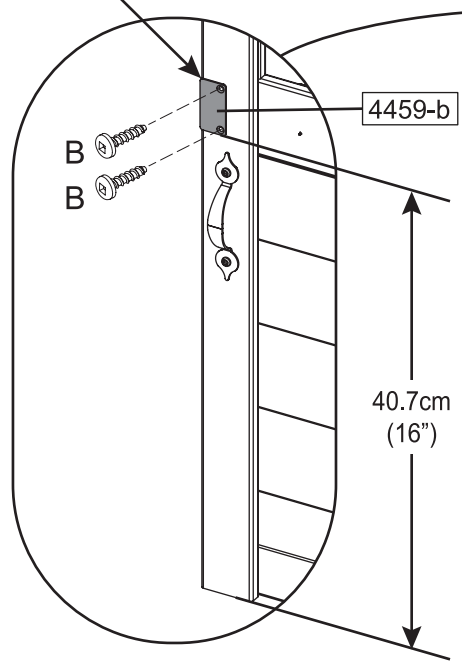

16

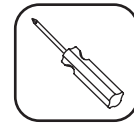

1 x ③

1 x 4459-a

2 x C

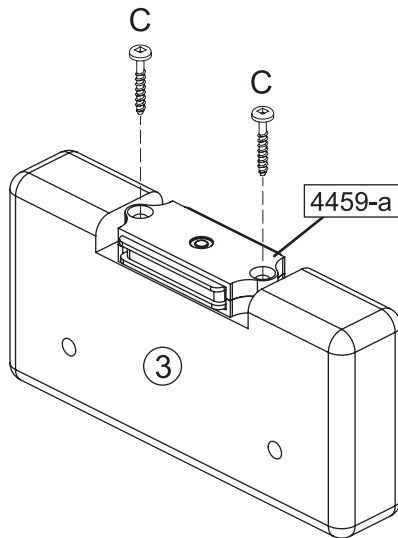

**Important: Use a hand held screw driver and DO NOT over tighten.**

**Important : Utiliser un tournevis manuel et ne PAS TROP serrer.**

**Importante: Use un destornillador de mano y no atornille en exceso.**

**Wichtig: Verwenden Sie einen Schraubenzieher und achten Sie darauf, die Schrauben NICHT zu fest anzuziehen.**

**Importante: usare un cacciavite a mano e NON serrare troppo.**

17



2 x G

Note: Close door and vertically center 4459-a to 4459-b to assemble.

Remarque : Fermer la porte et centrer verticalement 4459-a sur 4459-b pour réaliser l'assemblage.

Nota: Cierre la puerta y centre verticalmente 4459-a con 4459-b para el montaje.

Hinweis: Zum Zusammenbauen die Tür schließen und 4459-a vertikal an 4459-b zentrieren.

Nota: chiudere la porta e centrare verticalmente da 4459-a a 4459-b per assemblare.

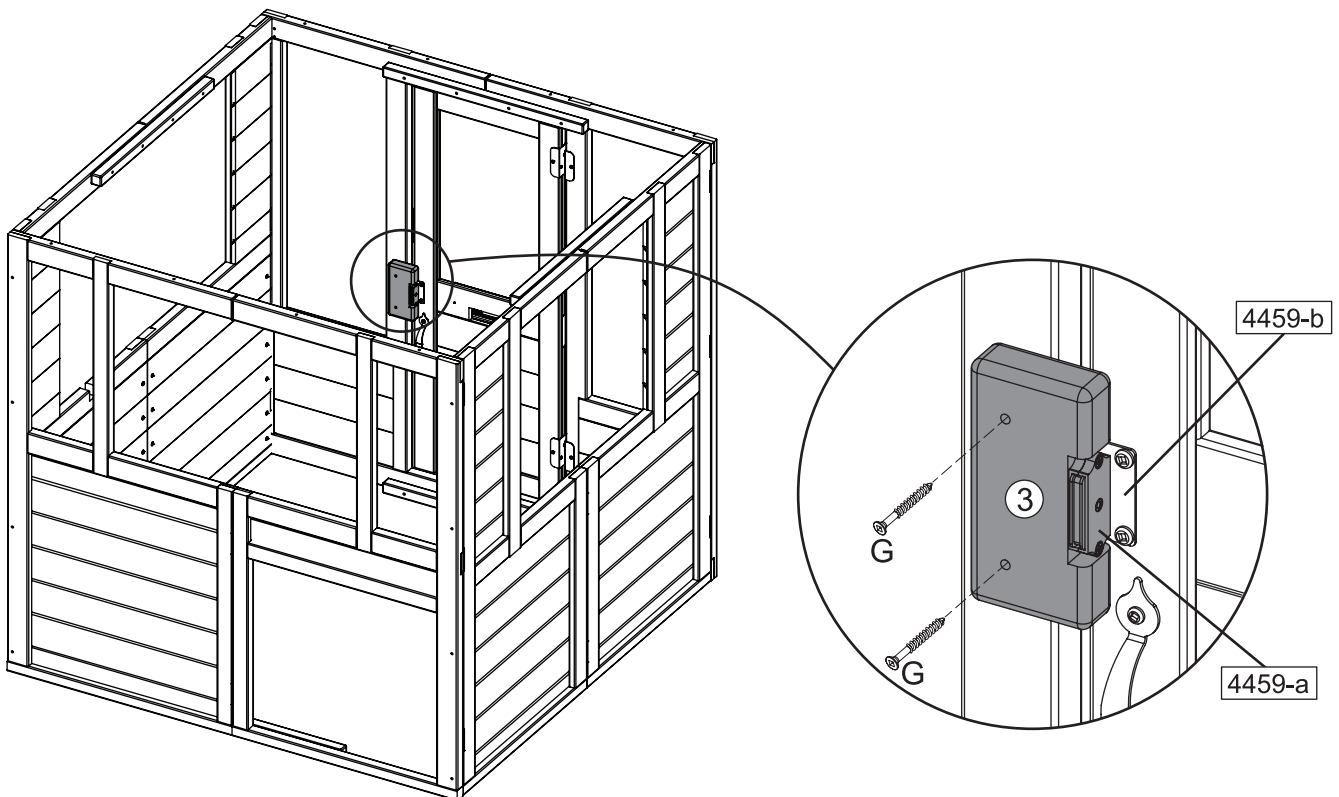

18



1 x 4754-WT

6 x B

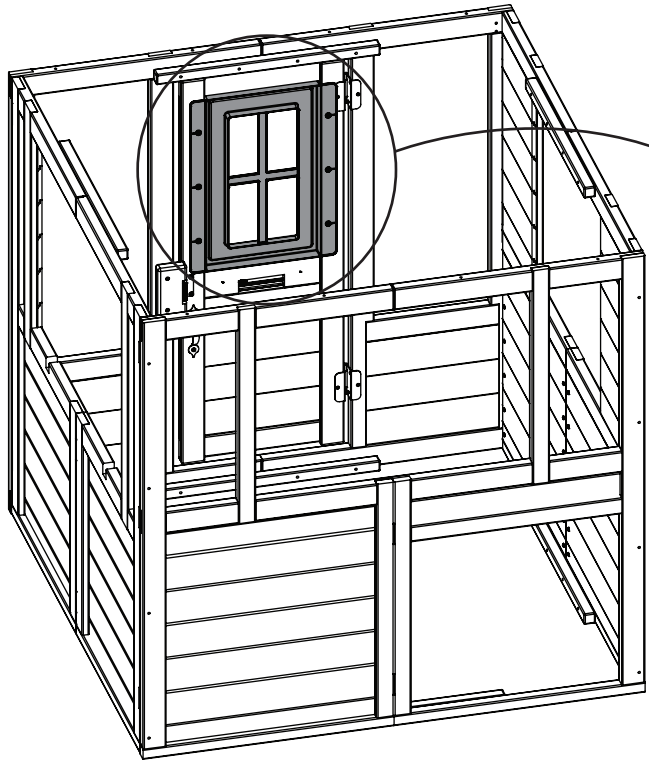

4754-WT

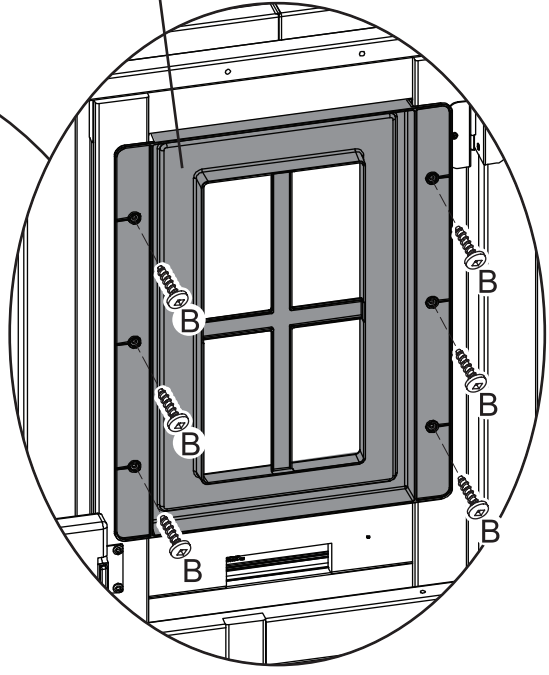

19



1 x 4457-WT

8 x B

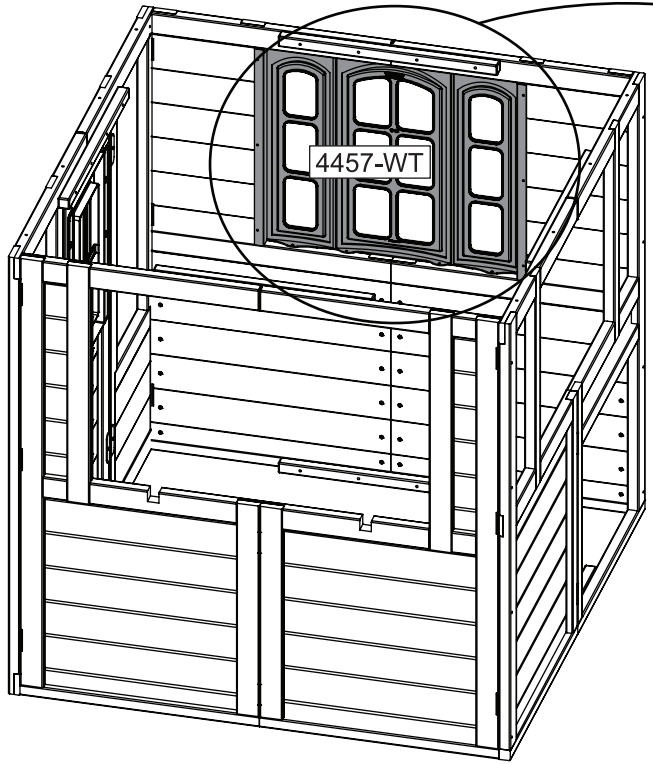

4457-WT

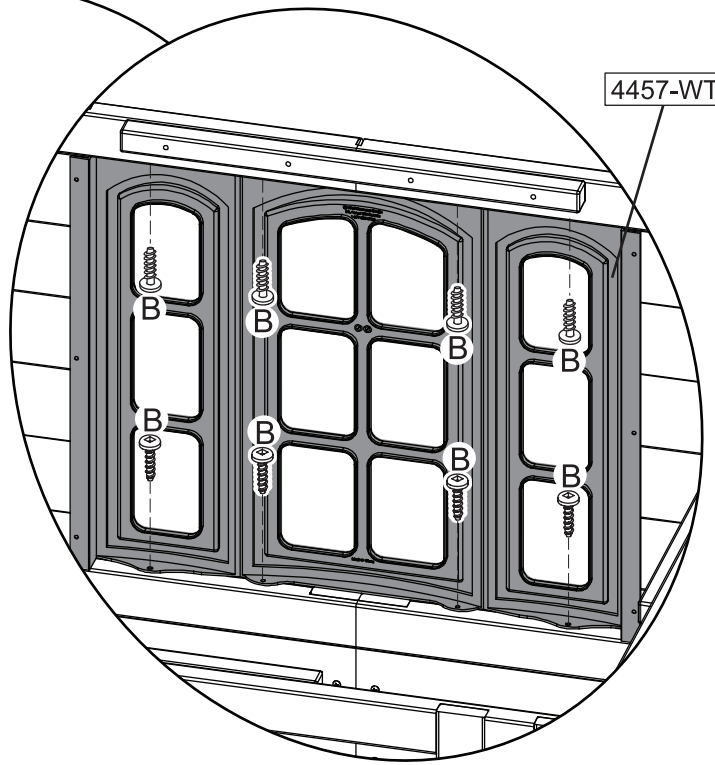

4457-WT

20

6 x B

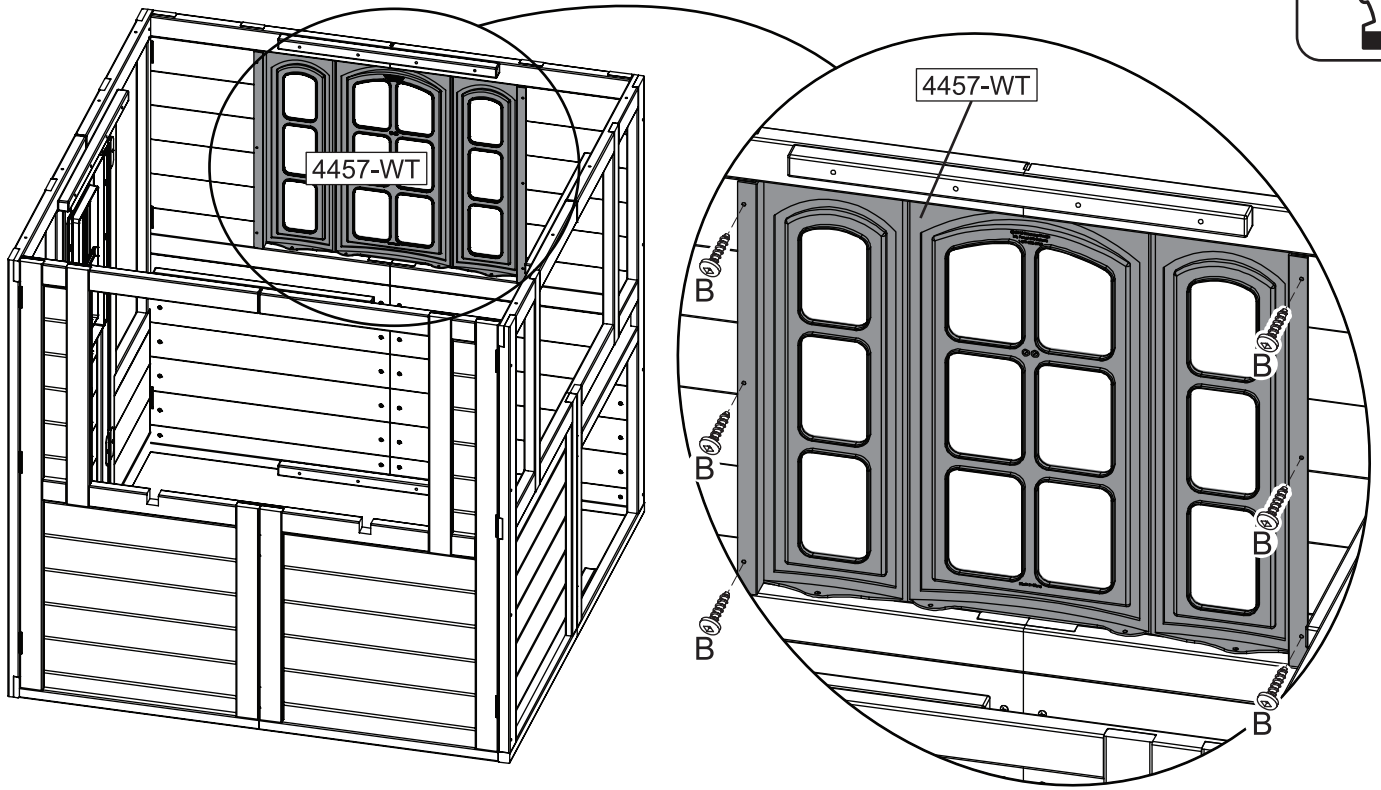

21

1 x ②

4 x E

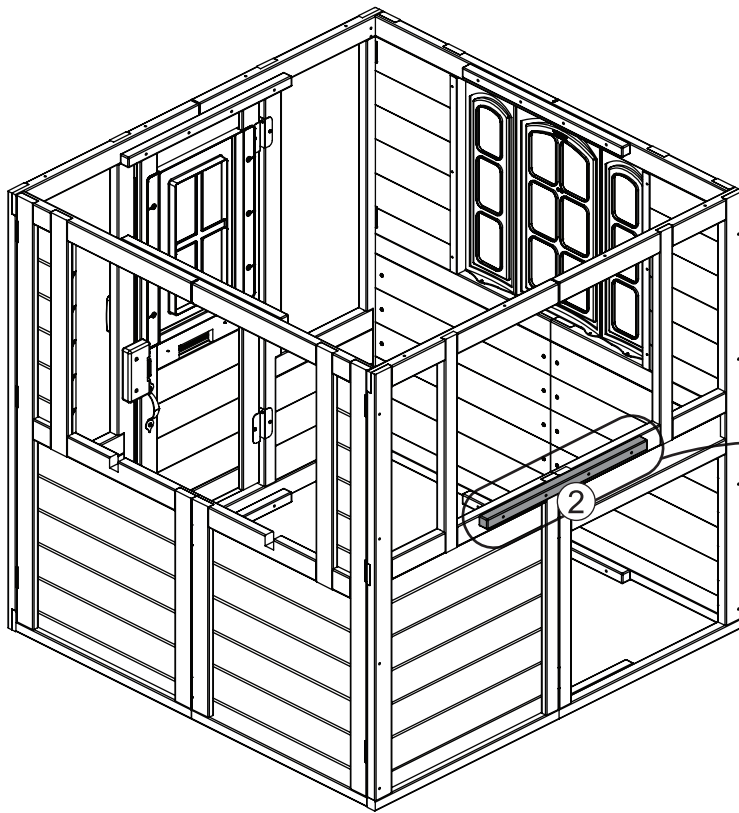

Note: Centered and Flush to edge  
 Remarque : Centré et aligné avec le bord  
 Nota: Centrado y a ras del borde  
 Hinweis: Zentriert und bündig an der Kante anliegend  
 Nota: centrato e a filo del margine

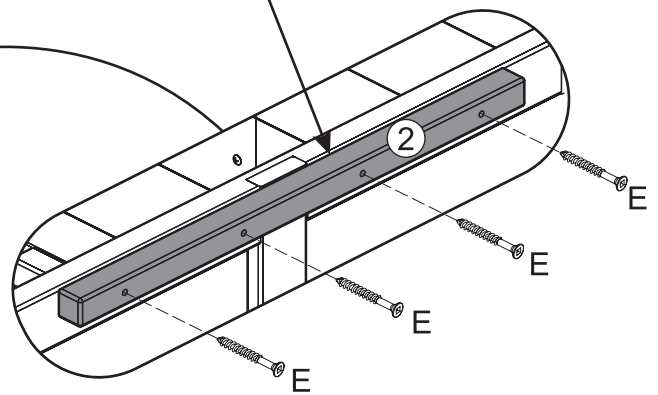

22



1 x 4

4 x E

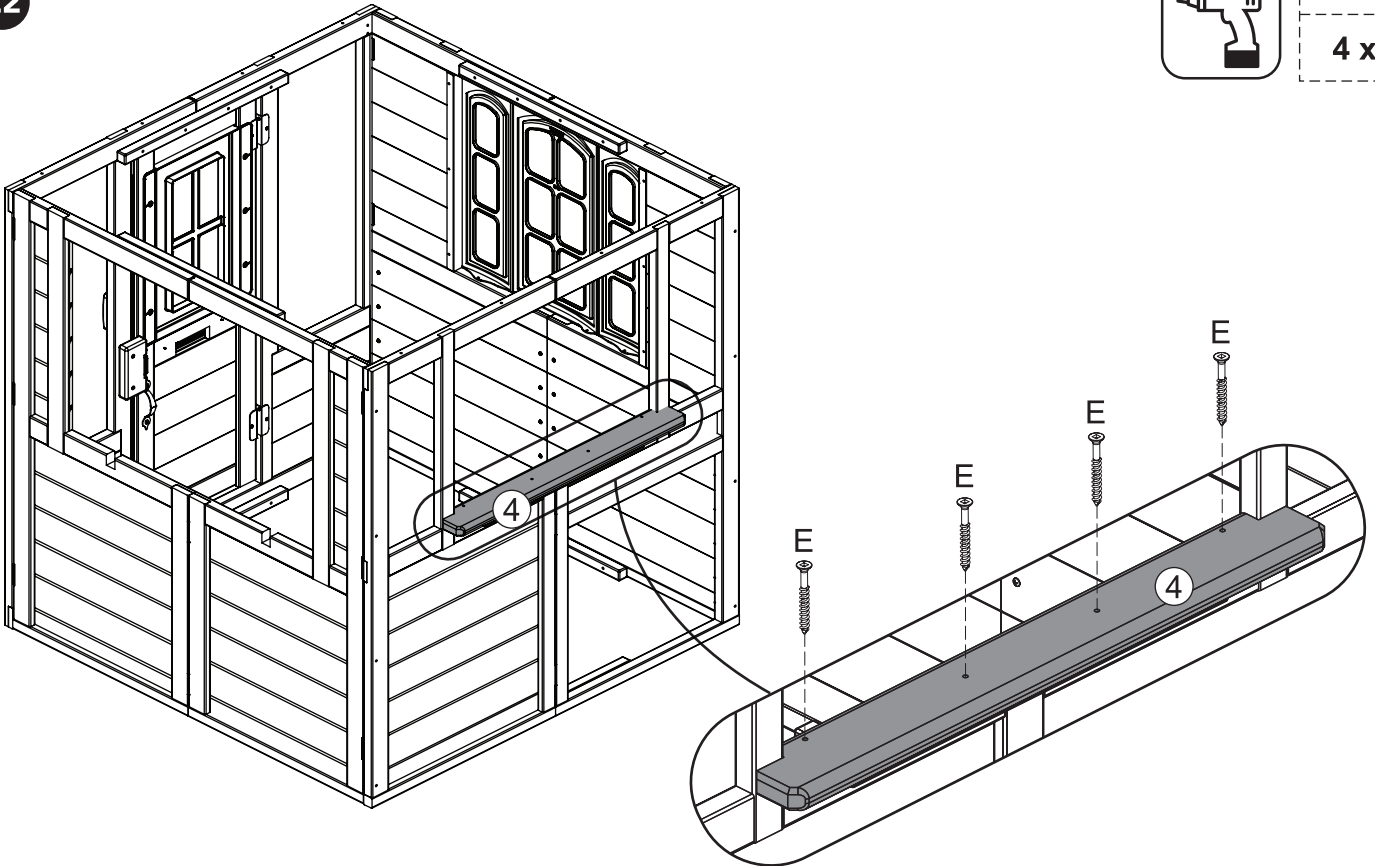

23

Note: Flush. Center horizontally to opening.  
Remarque : Aligné. Centrer horizontalement sur l'ouverture.  
Nota: A ras. Centrar horizontalmente con la abertura.  
Hinweis: Bündig. Horizontal an der Öffnung zentrieren.  
Nota: a filo. Centrare orizzontalmente all'apertura.

1 x 5296-RD

4 x B  
4 x D

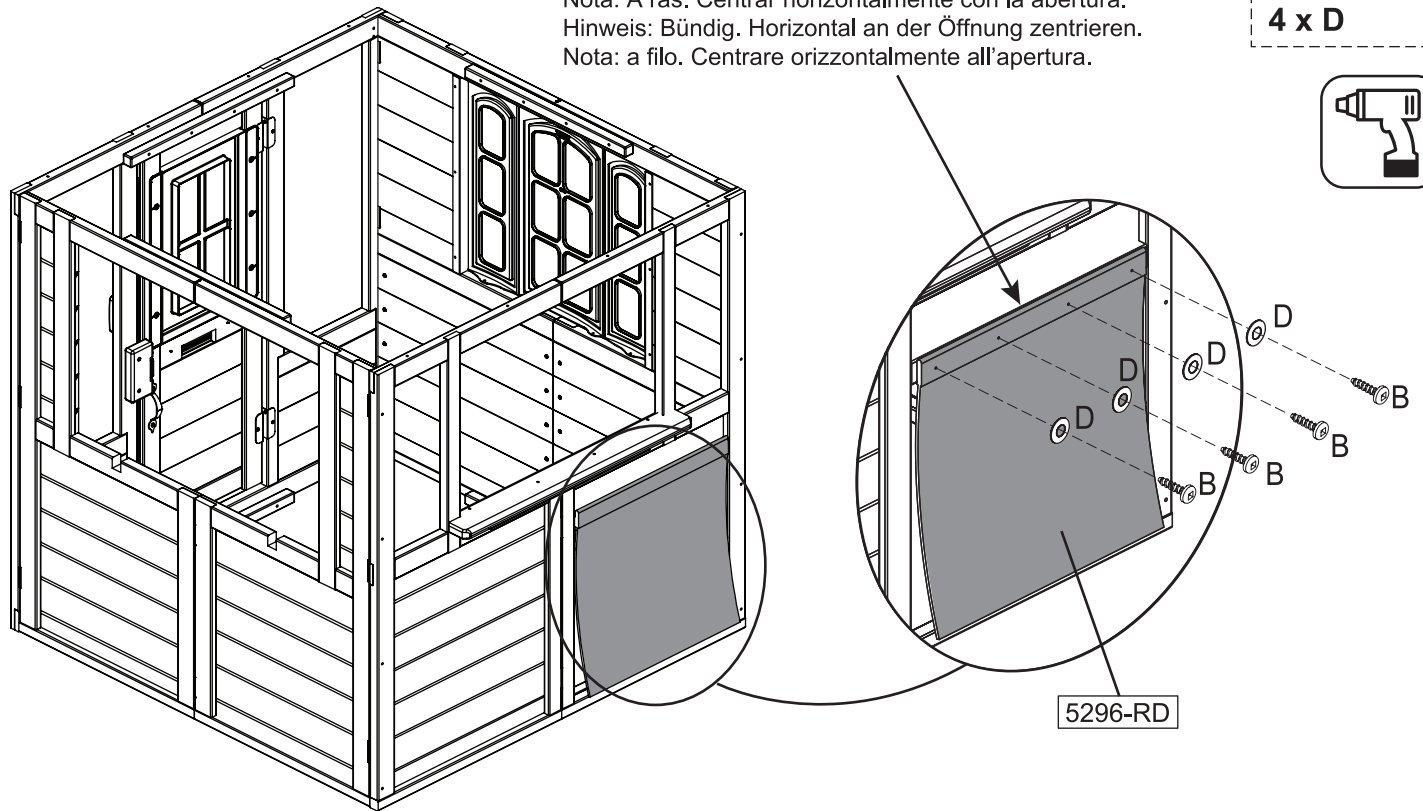

parts.kidkraft.com

customerservice@kidkraft.com  
1.800.933.0771  
972.385.0100

24

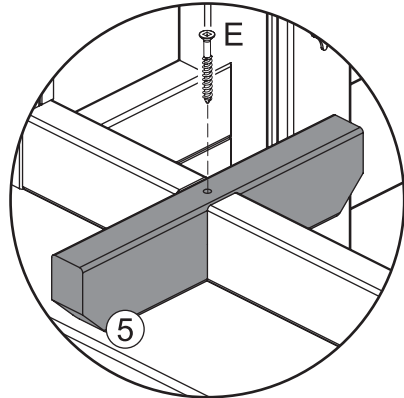
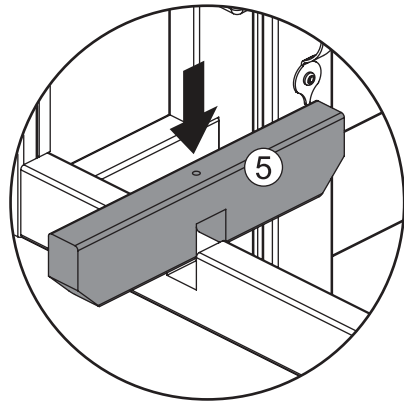
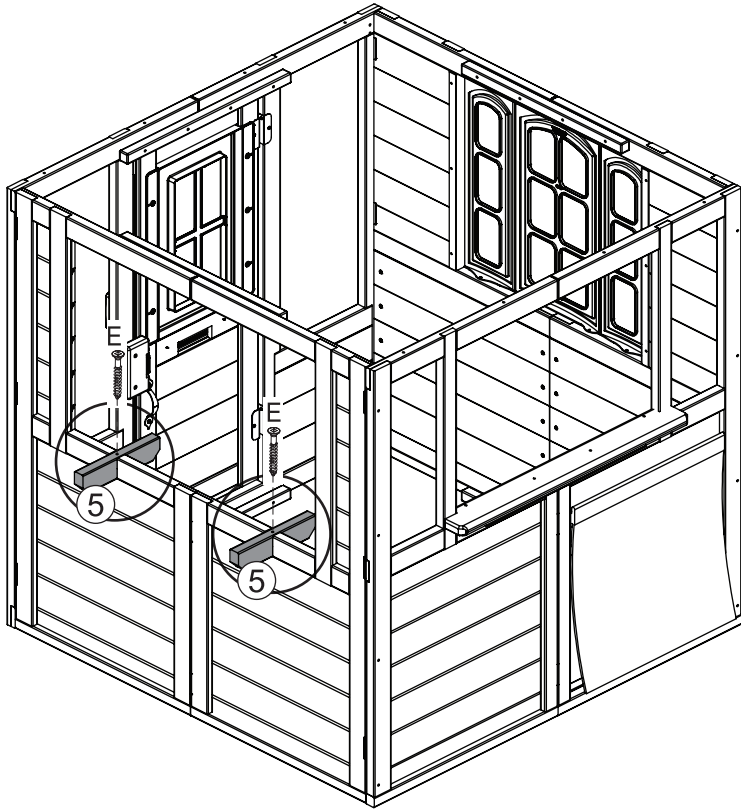

2 x 5

2 x E



25

Note: Centered and Flush to edge  
 Remarque : Centré et aligné avec le bord  
 Nota: Centrado y a ras del borde  
 Hinweis: Zentriert und bündig an der Kante anliegend  
 Nota: centrato e a filo del margine

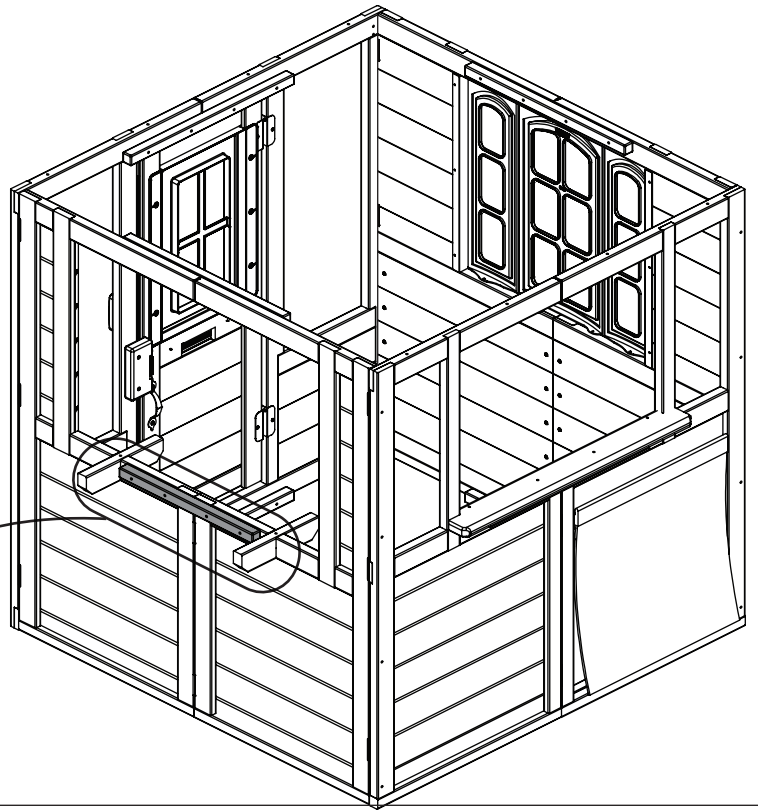
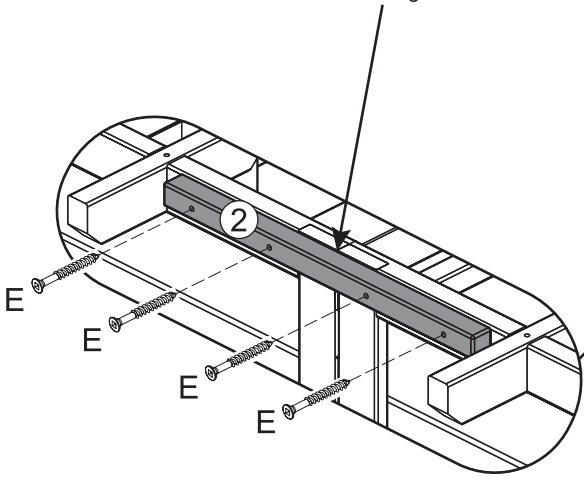

1 x 2

4 x E



26



1 x 7

6 x C

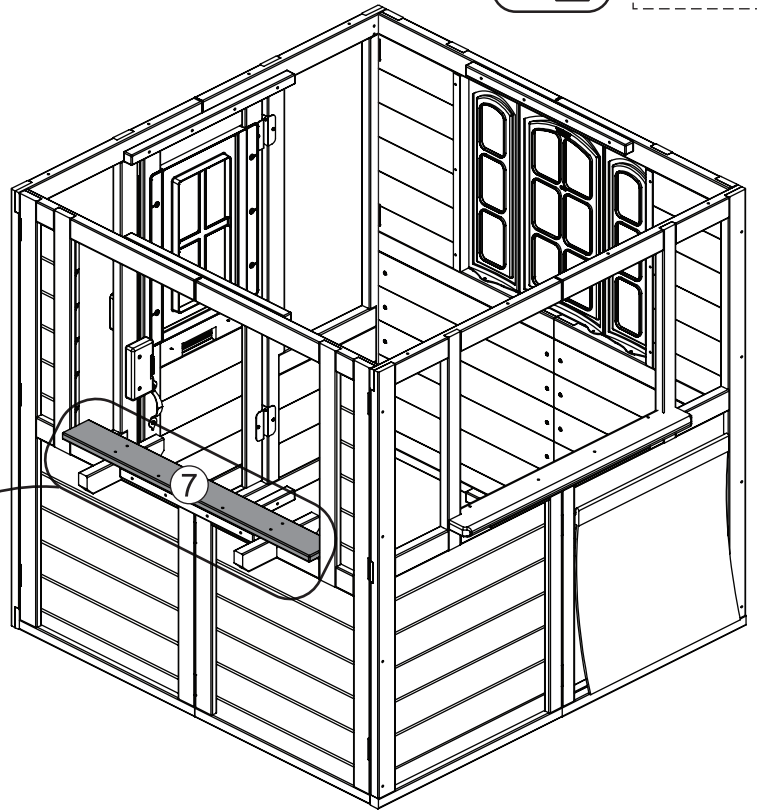
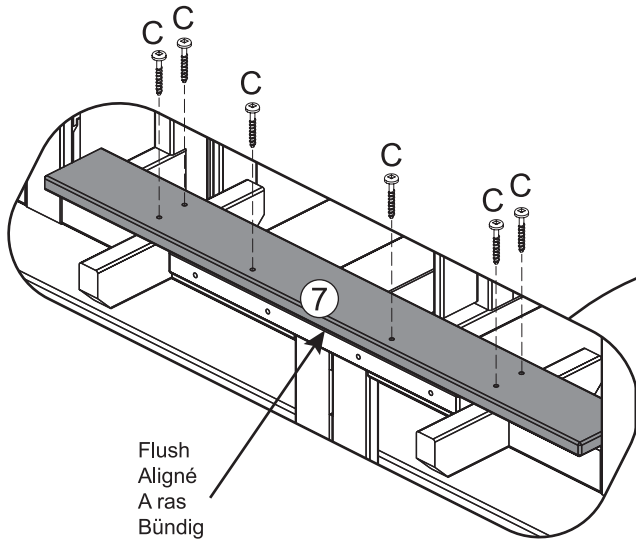

27



2 x 8

8 x C

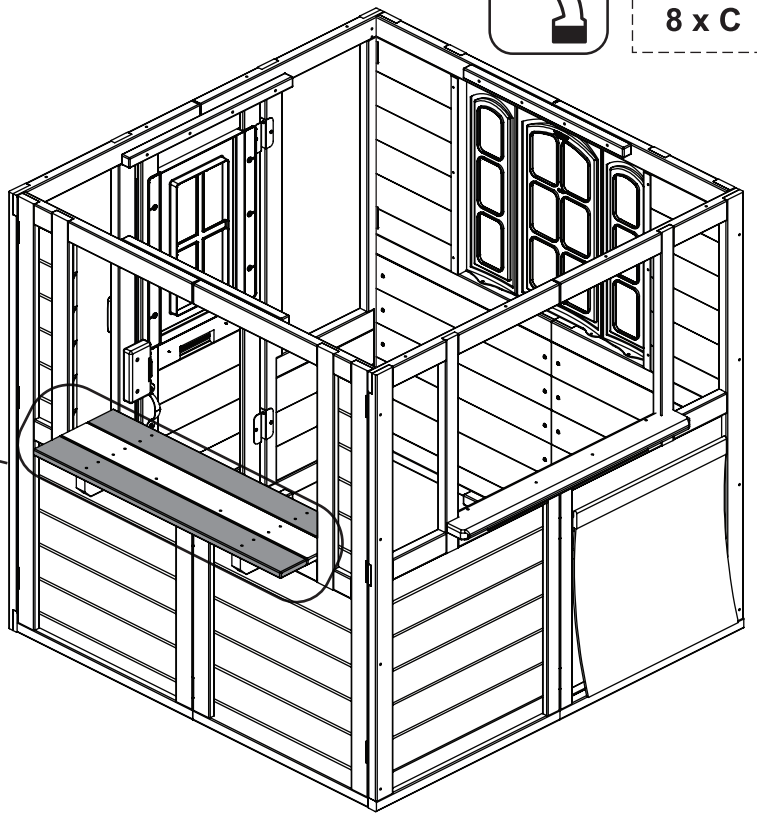
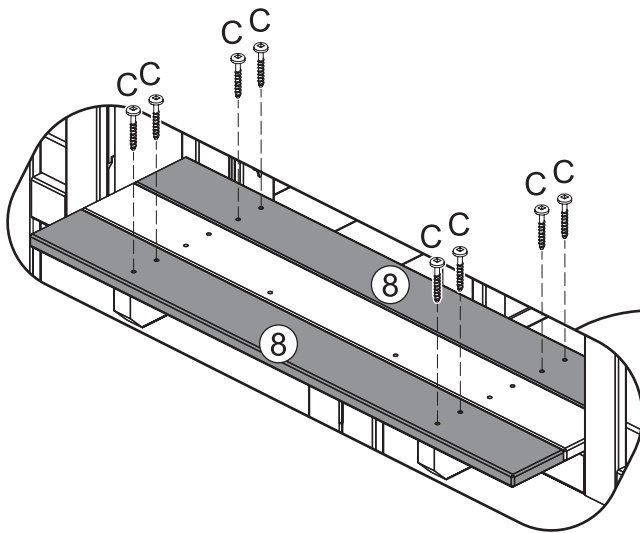

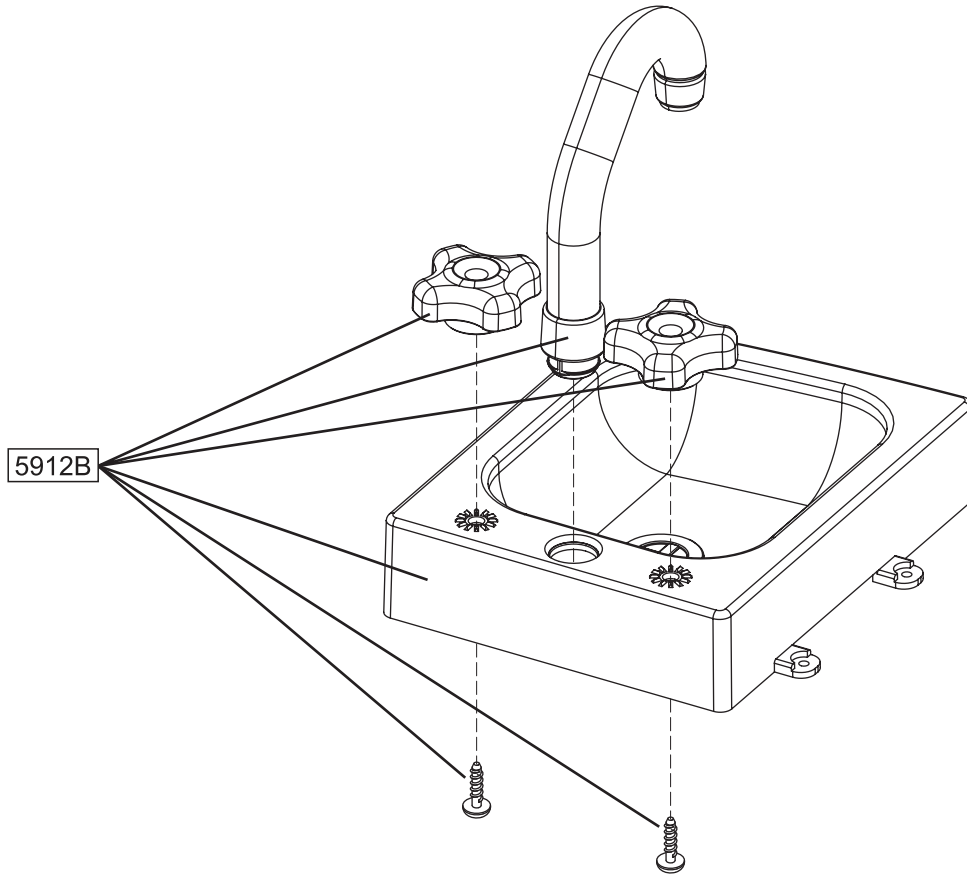
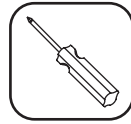

**Important: Use a hand held screw driver and DO NOT over tighten.**

**Important : Utiliser un tournevis manuel et ne PAS TROP serrer.**

**Importante: Use un destornillador de mano y no atornille en exceso.**

**Wichtig: Verwenden Sie einen Schraubenzieher und achten Sie darauf, die Schrauben NICHT zu fest anzuziehen.**

**Importante: usare un cacciavite a mano e NON serrare troppo.**

29



1 x 5912A

6 x B

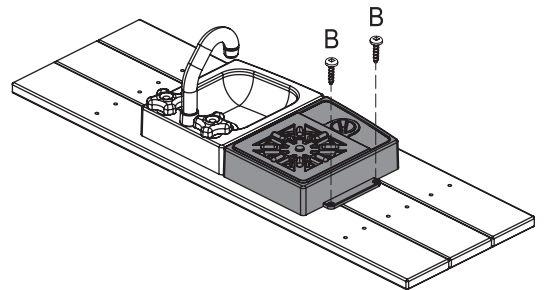
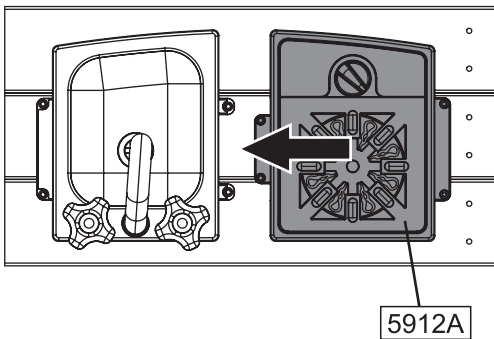
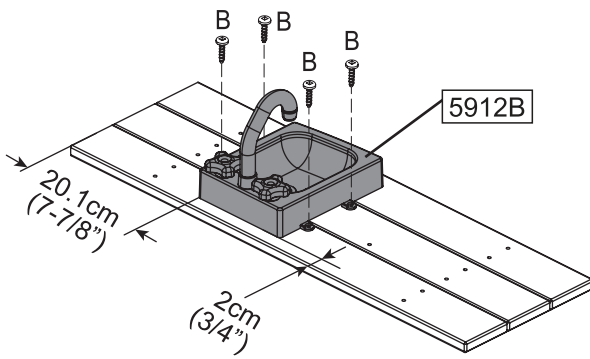
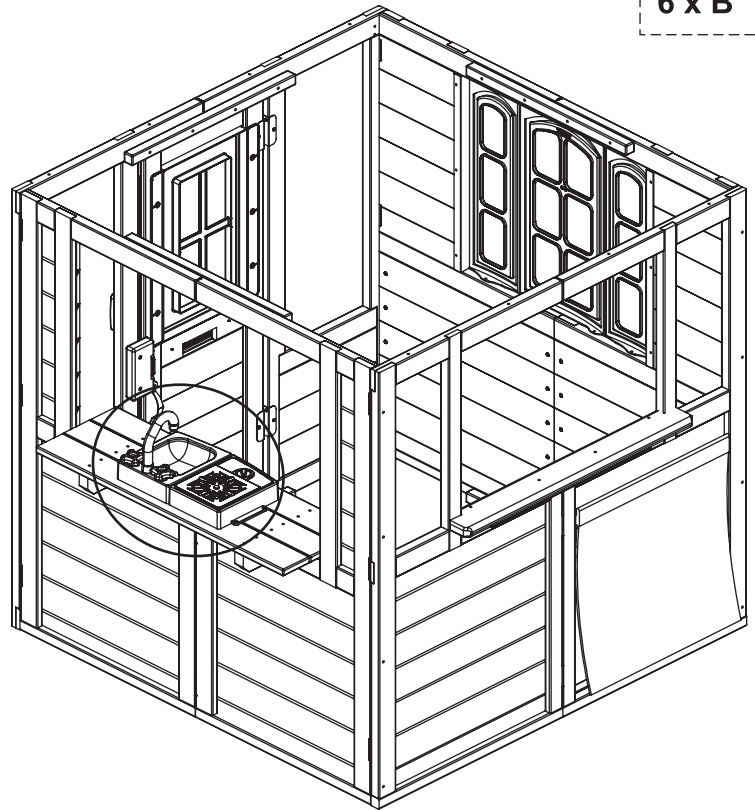

30



1 x 4463-STGY

2 x B

Note: Flush and centered  
Remarque : Aligné et centré  
Nota: A ras y centrado  
Hinweis: Bündig und zentriert  
Nota: a filo e centrato

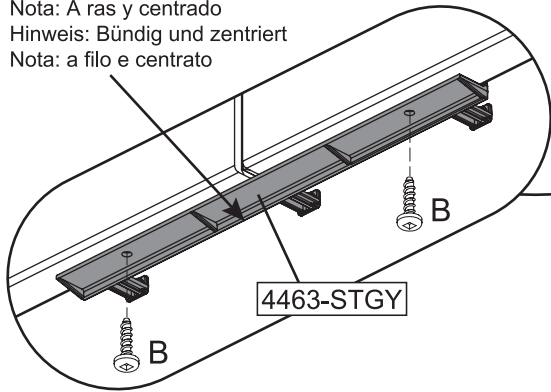

4463-STGY

Underneath View / Vue de dessous / Vista inferior /  
Unteransicht / Vista dal basso

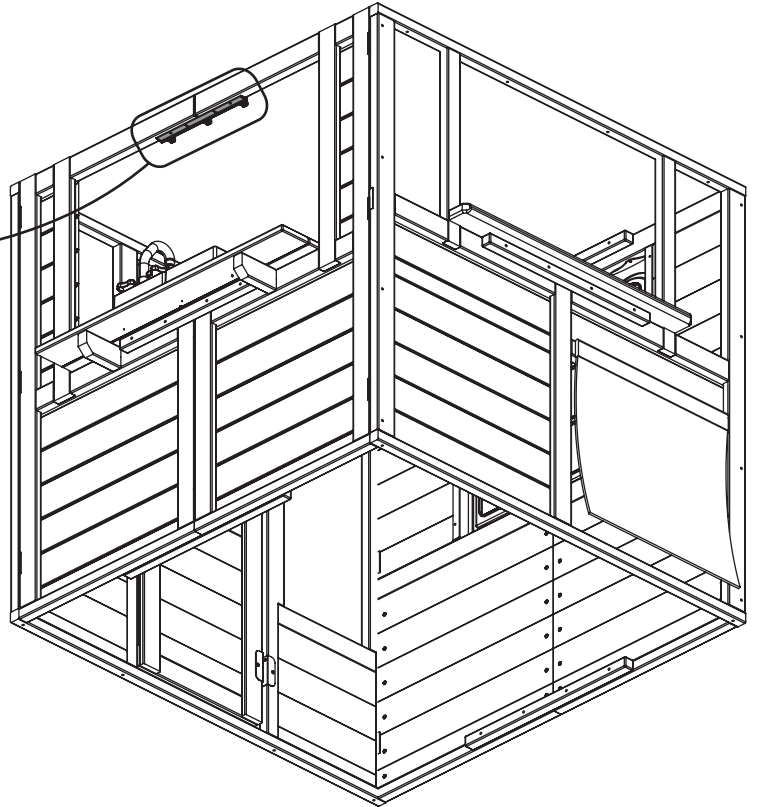

31



2 x 9

2 x 10

2 x H

2 x I

Complete this step twice  
Répétez cette étape deux fois  
Repita este paso dos veces  
Wiederholen Sie diesen Schritt zweimal  
Eseguire questo passaggio due volte

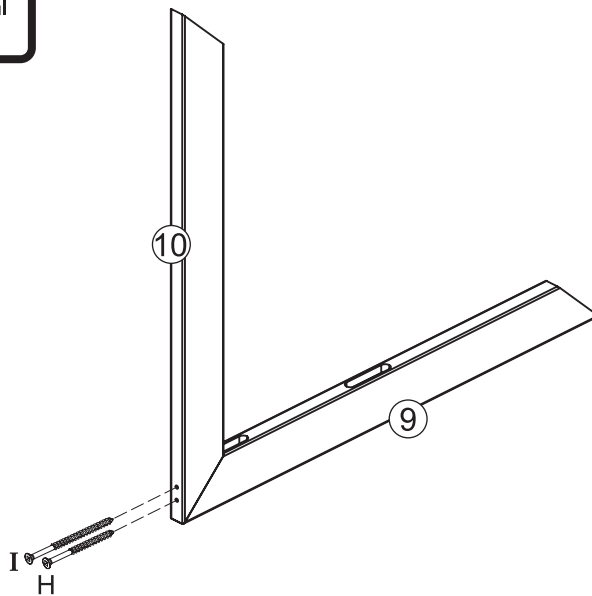

32

Complete this step twice  
Répétez cette étape deux fois  
Repita este paso dos veces  
Wiederholen Sie diesen Schritt zweimal  
Eseguire questo passaggio due volte

2 x 11  
4 x 12

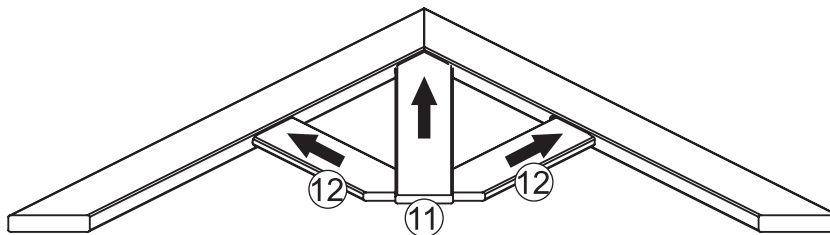

33

Complete this step twice  
Répétez cette étape deux fois  
Repita este paso dos veces  
Wiederholen Sie diesen Schritt zweimal  
Eseguire questo passaggio due volte

2 x 13

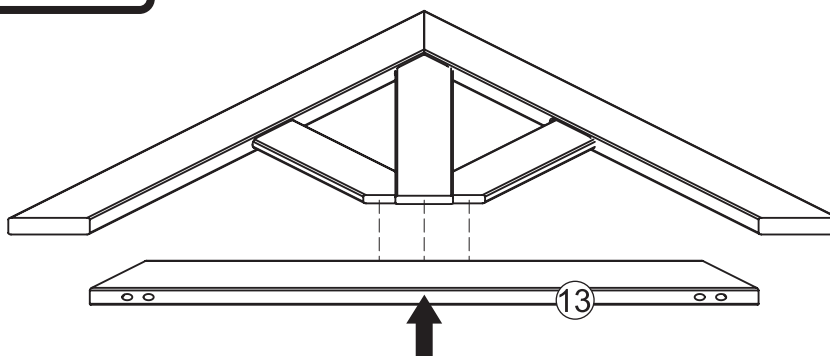

34

Complete this step twice  
Répétez cette étape deux fois  
Repita este paso dos veces  
Wiederholen Sie diesen Schritt zweimal  
Eseguire questo passaggio due volte



4 x H  
4 x I

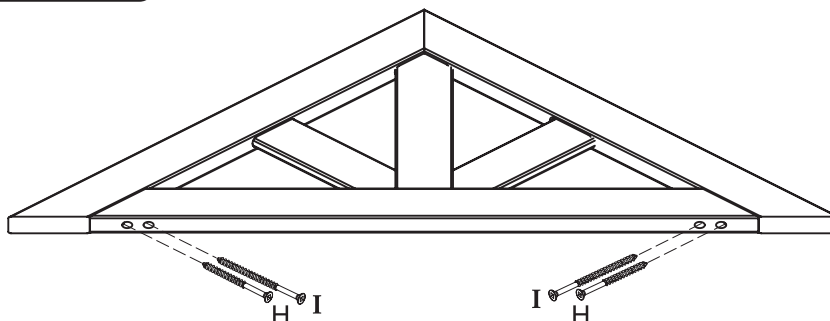

35



4 x I

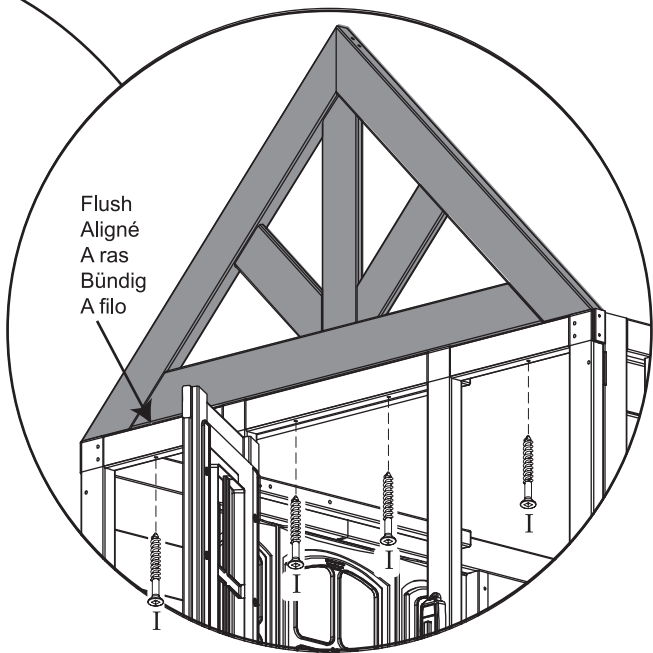
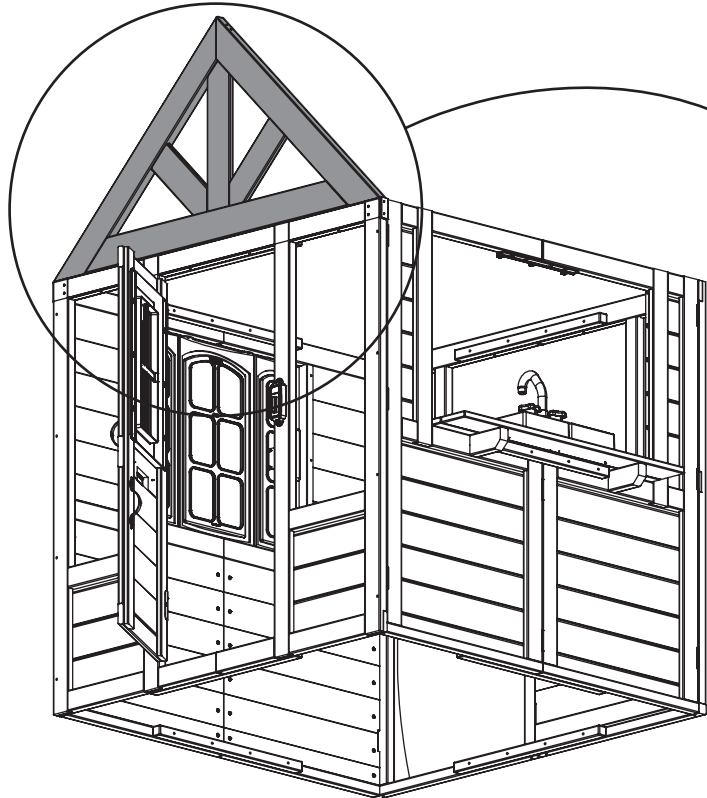

36



4 x I

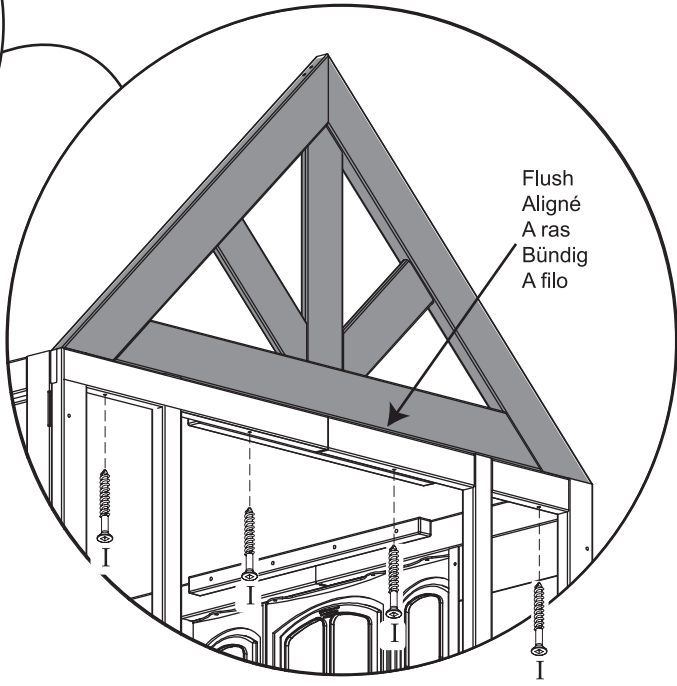
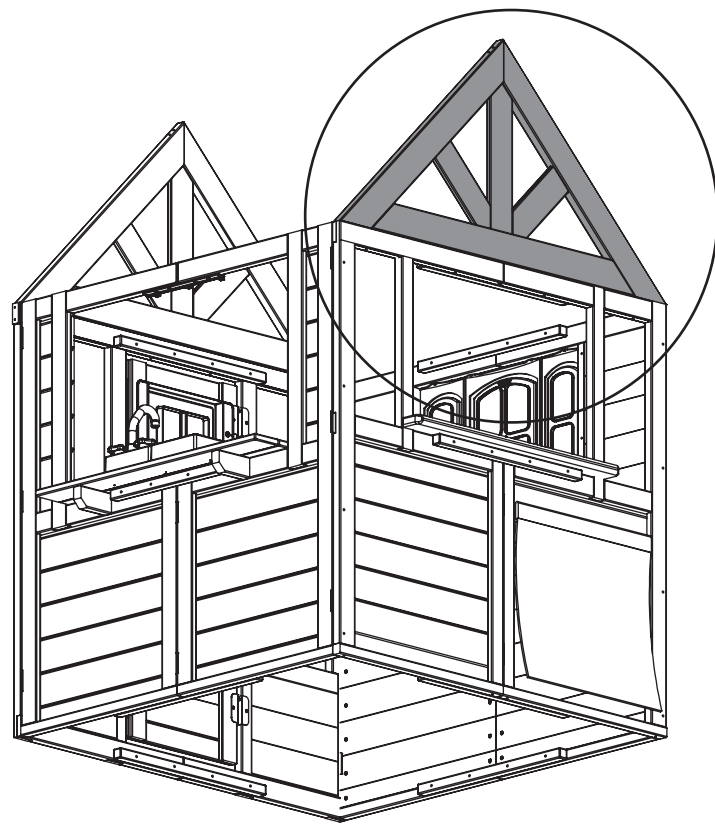

parts.kidkraft.com

customerservice@kidkraft.com  
1.800.933.0771  
972.385.0100

37

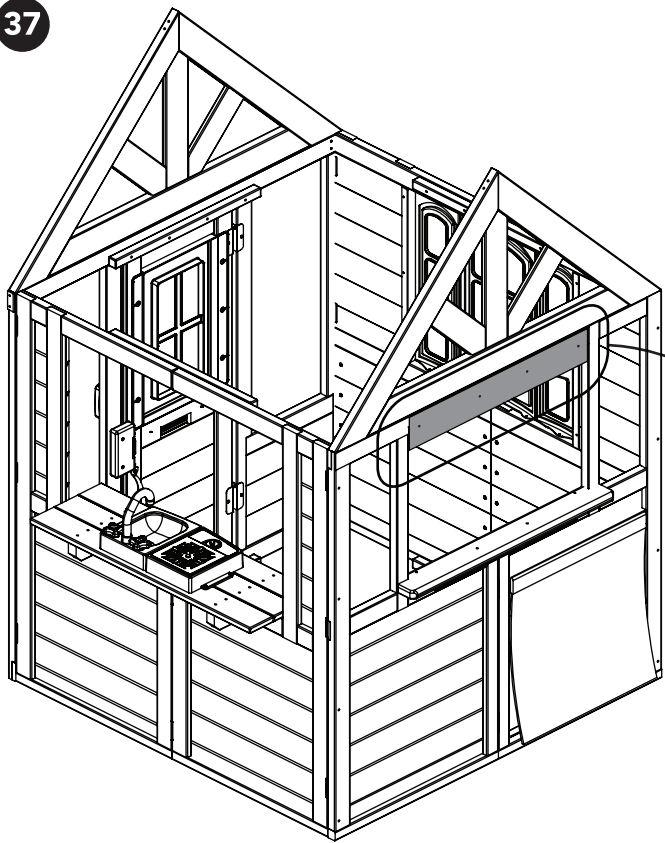

1 x 5913-RD

4 x B  
4 x D

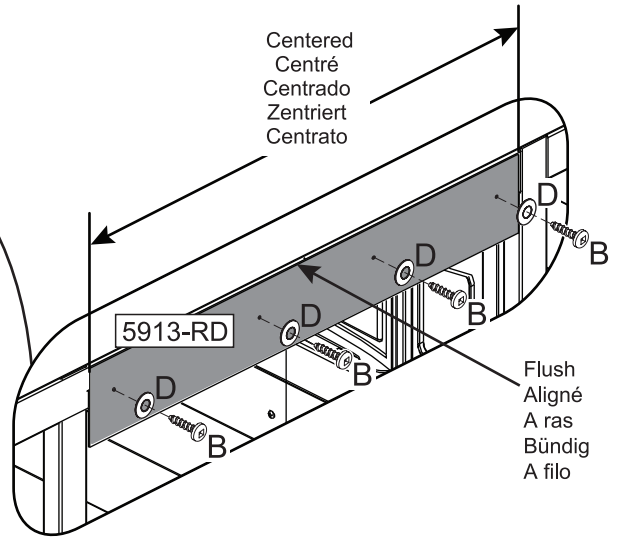

Centered  
Centré  
Centrado  
Zentriert  
Centrato

Flush  
Aligné  
A ras  
Bündig  
A filo

38

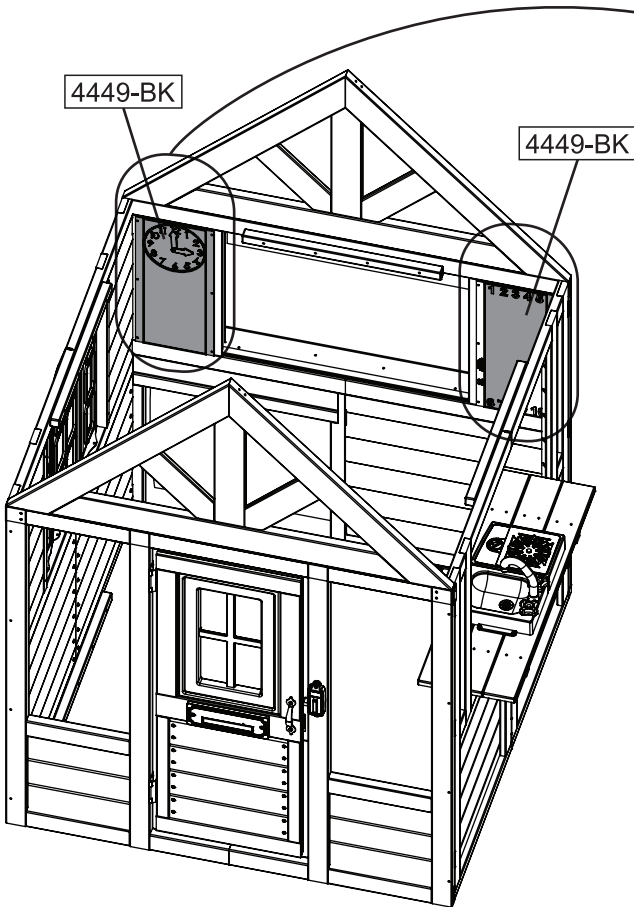

4449-BK

4449-BK

2 x 4449-BK

12 x B

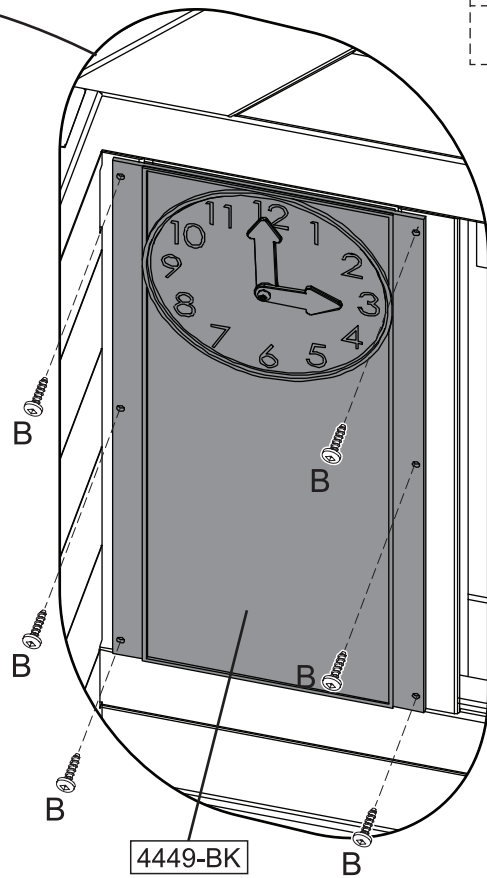

4449-BK

B

39

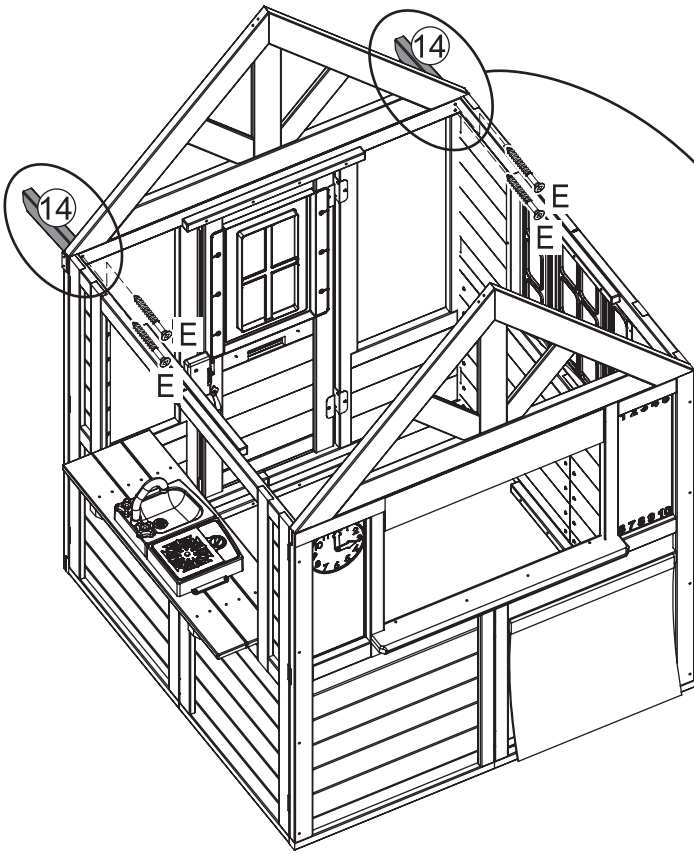

Flush  
Aligné  
A ras  
Bündig  
A filo



2 x 14

4 x E

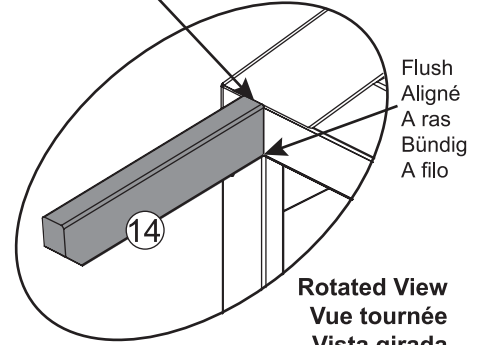

Flush  
Aligné  
A ras  
Bündig  
A filo

Rotated View  
Vue tournée  
Vista girada  
Gedrehte Ansicht  
Nuovo orientamento

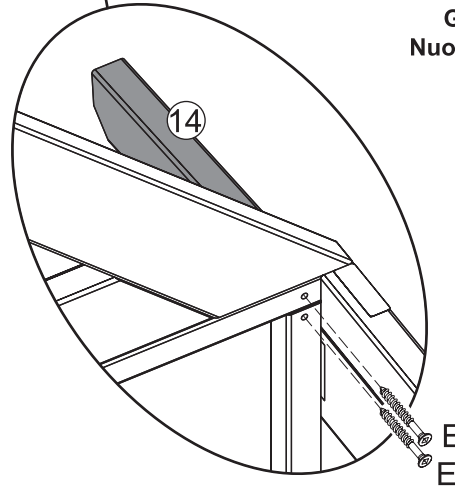

40

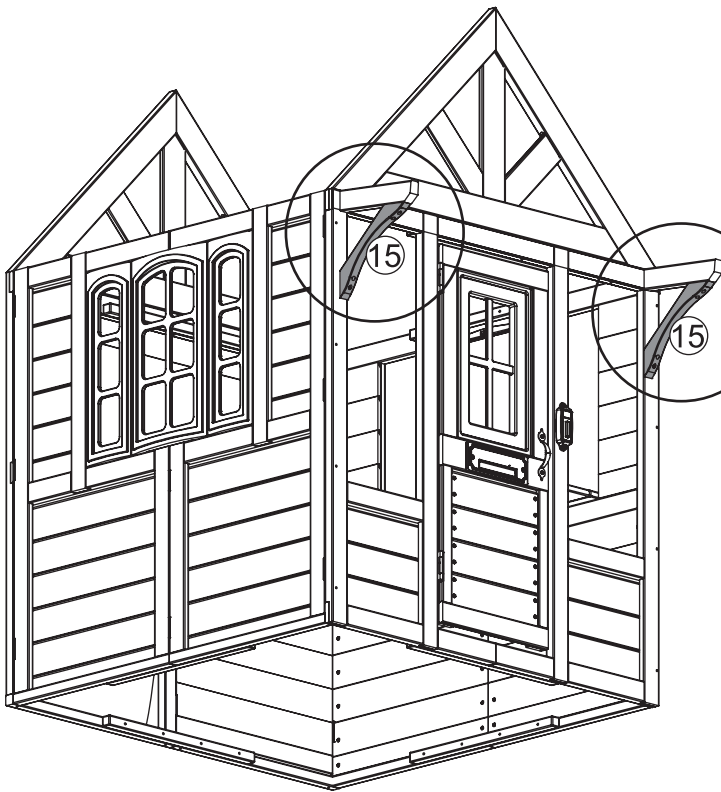

2 x 15

4 x E

4 x F

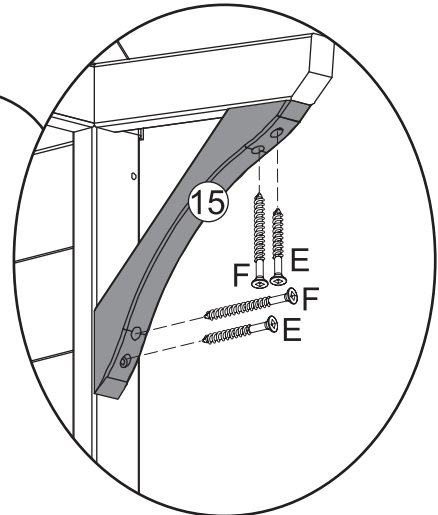



41

Note: Center panels horizontally across parts 14.  
 Remarque : Centrer les panneaux horizontalement sur les parties 14.  
 Nota: Centre los paneles horizontalmente a través de las piezas 14.  
 Hinweis: Platten horizontal an Teil 14 zentrieren.  
 Nota: centrare i pannelli orizzontalmente sulle parti 14.

2 x 16

1 x 17

12 x A

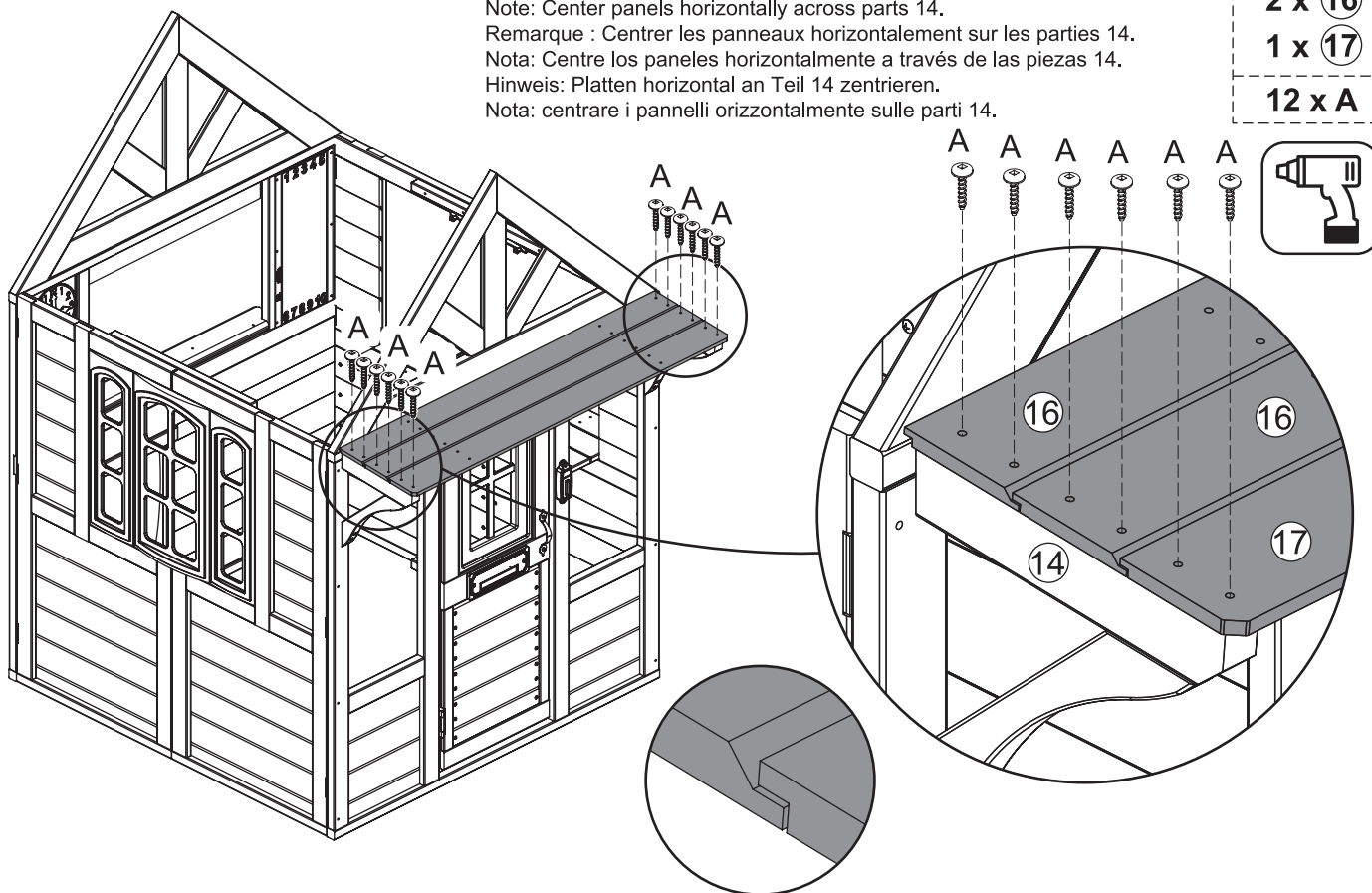

42

Note: Center part 18 horizontally to thru holes on parts 16, 17.  
 Remarque : Centrer la partie 18 horizontalement par rapport aux trous  
 traversants des parties 16 et 17.  
 Nota: Centre la pieza 18 horizontalmente con los orificios en las piezas 16 y 17.  
 Hinweis: Teil 18 horizontal an den Bohrungen der Teile 16 und 17 zentrieren.  
 Nota: centrare la parte 18 orizzontalmente sui fori delle parti 16 e 17.

2 x 18

12 x A

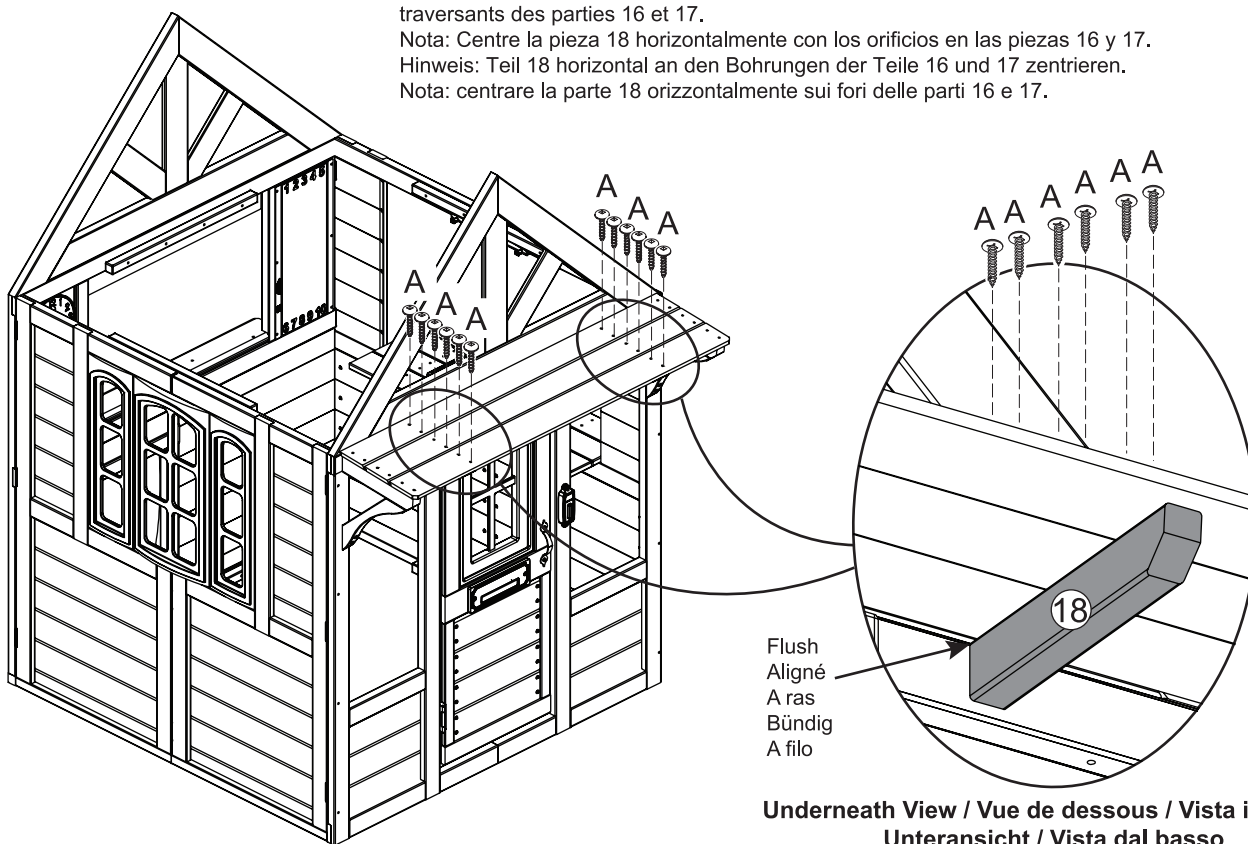

43

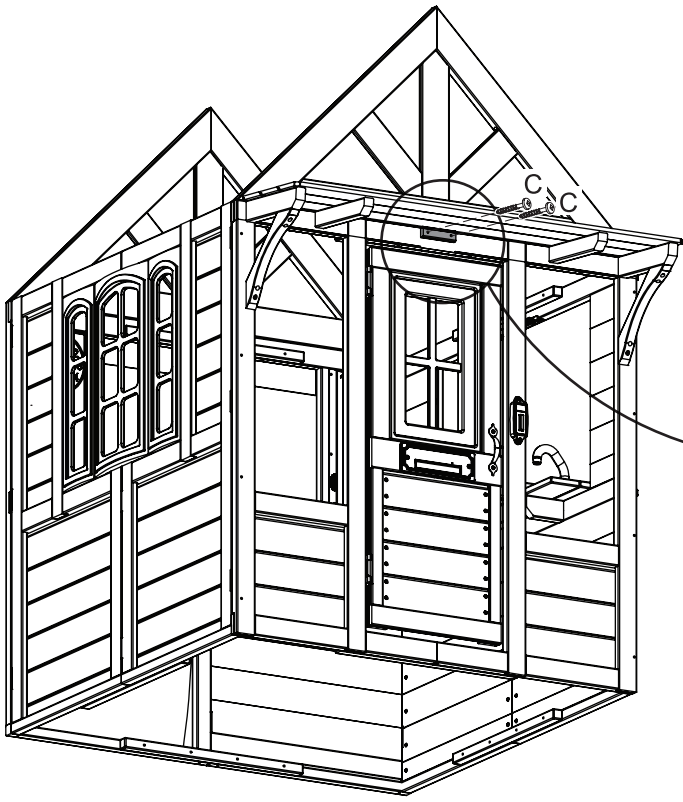

Flush  
Aligné  
A ras  
Bündig  
A filo

1 x 19

2 x C

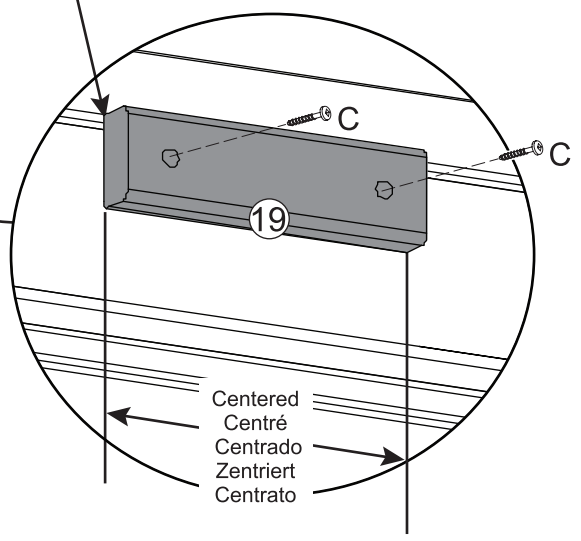

Centered  
Centré  
Centrado  
Zentriert  
Centrato

44

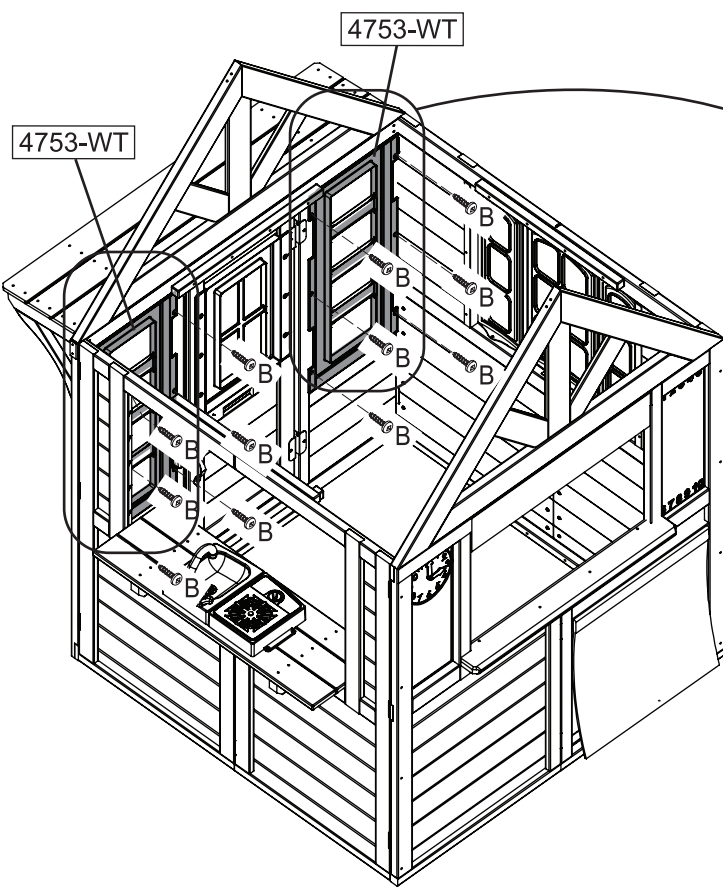

2 x 4753-WT

12 x B

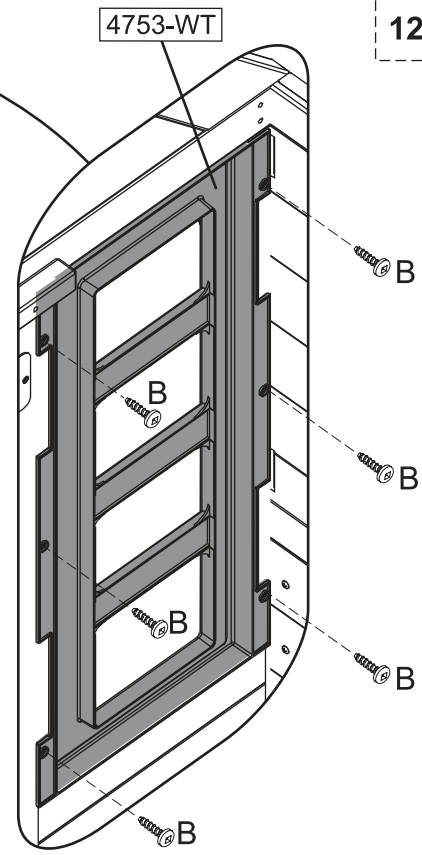

parts.kidkraft.com

customerservice@kidkraft.com  
1.800.933.0771  
972.385.0100

45

1 x 5915-MNRV

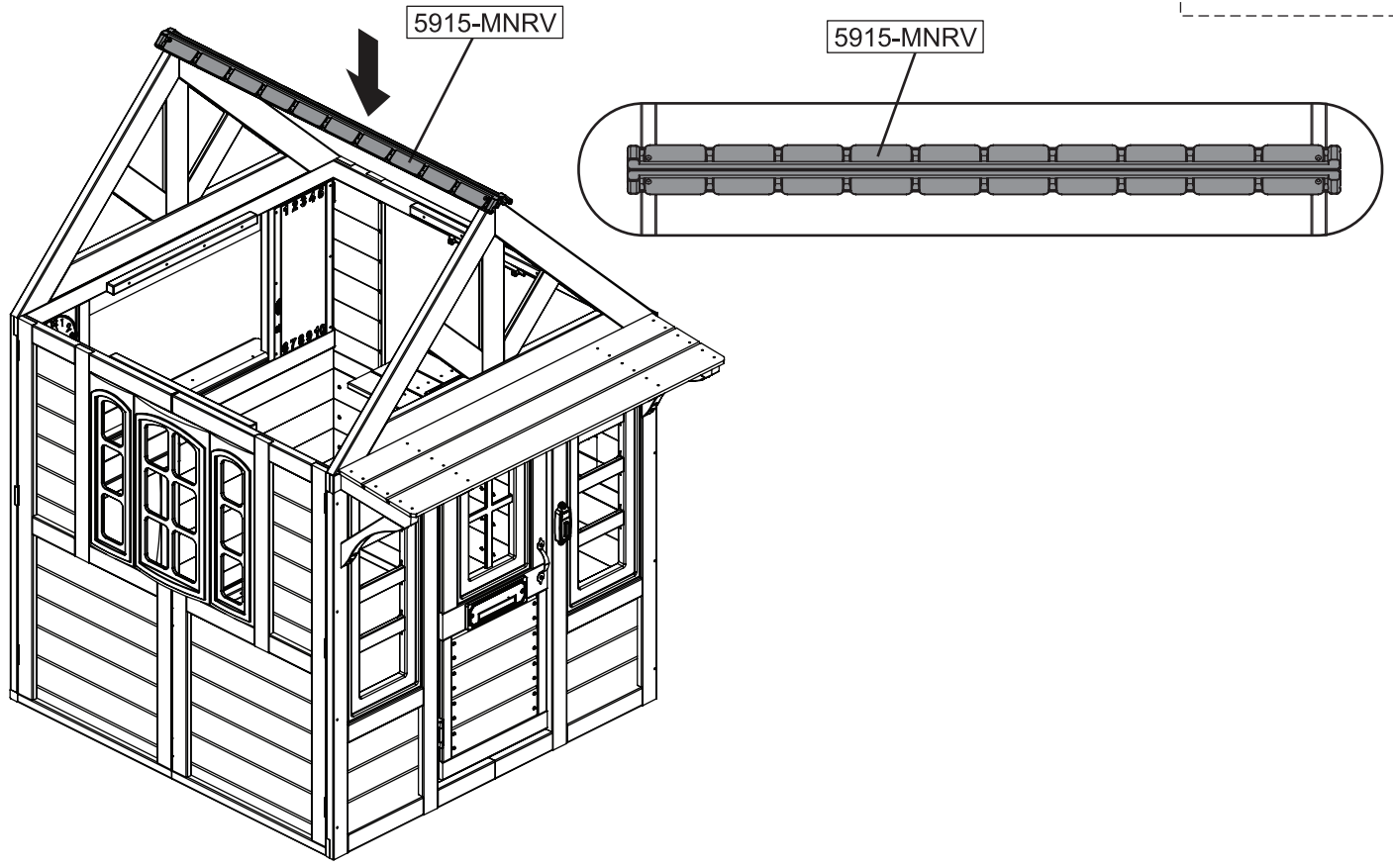

46

1 x 5312-MNRV

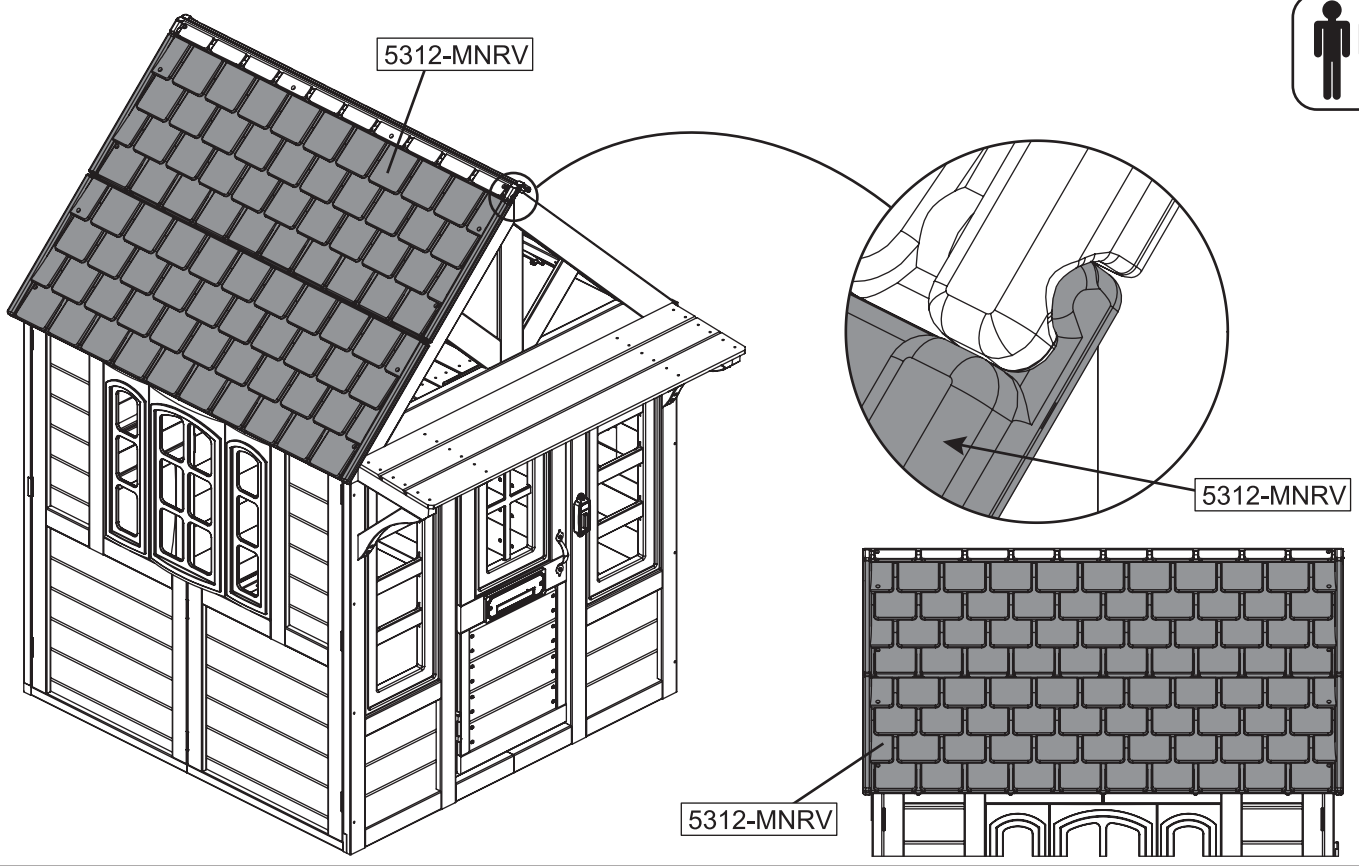

47

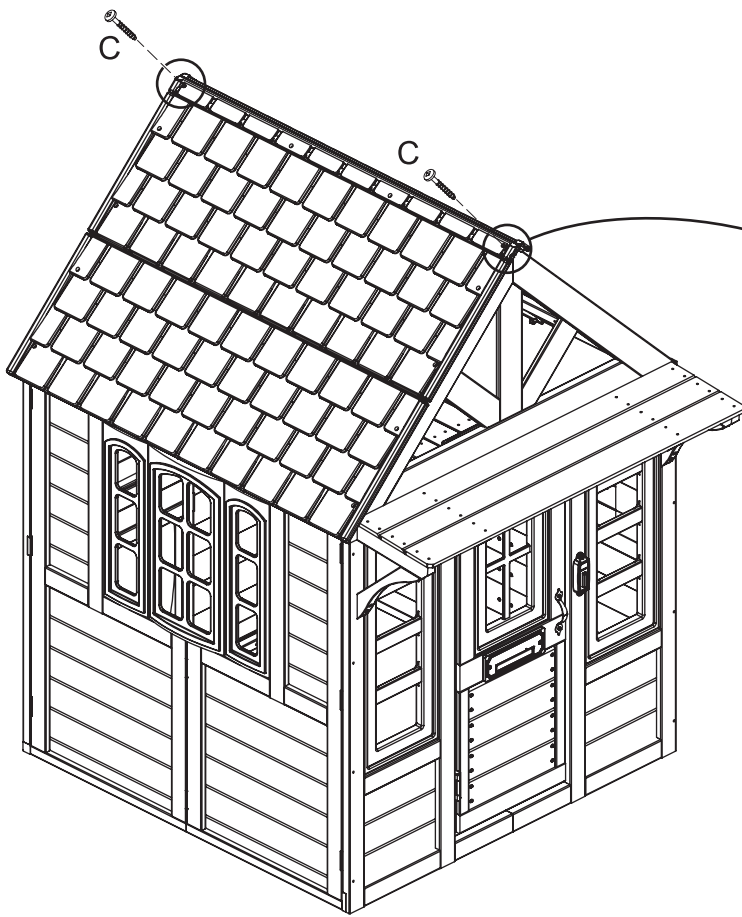

2 x C



5915-MNRV

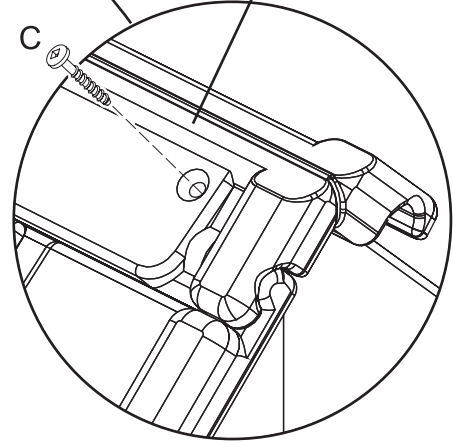

48

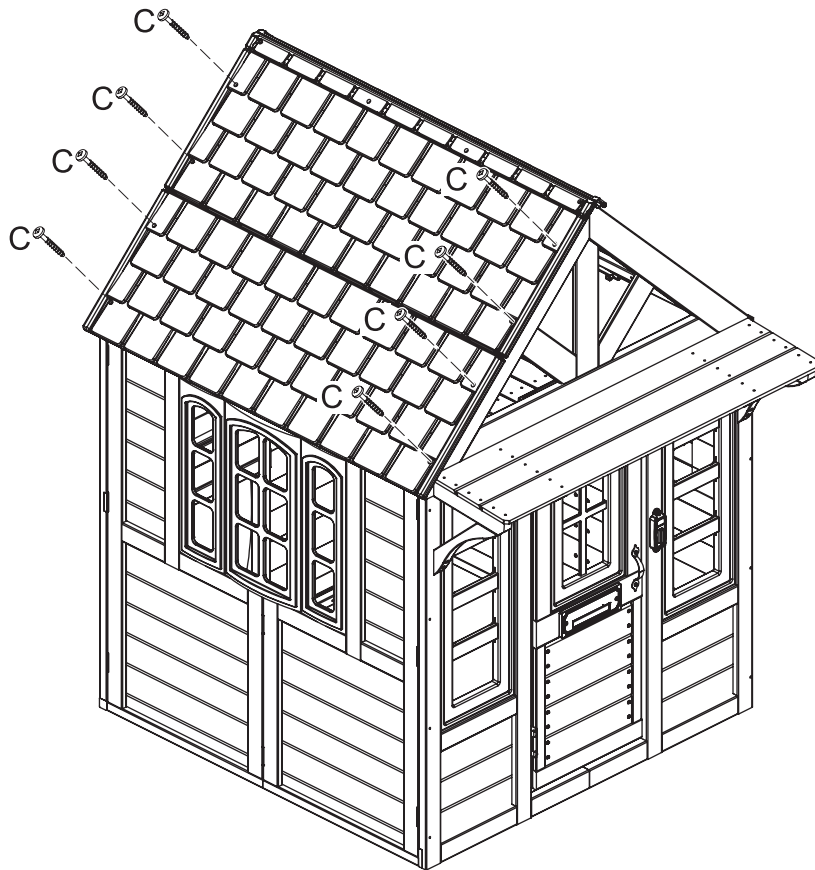

8 x C



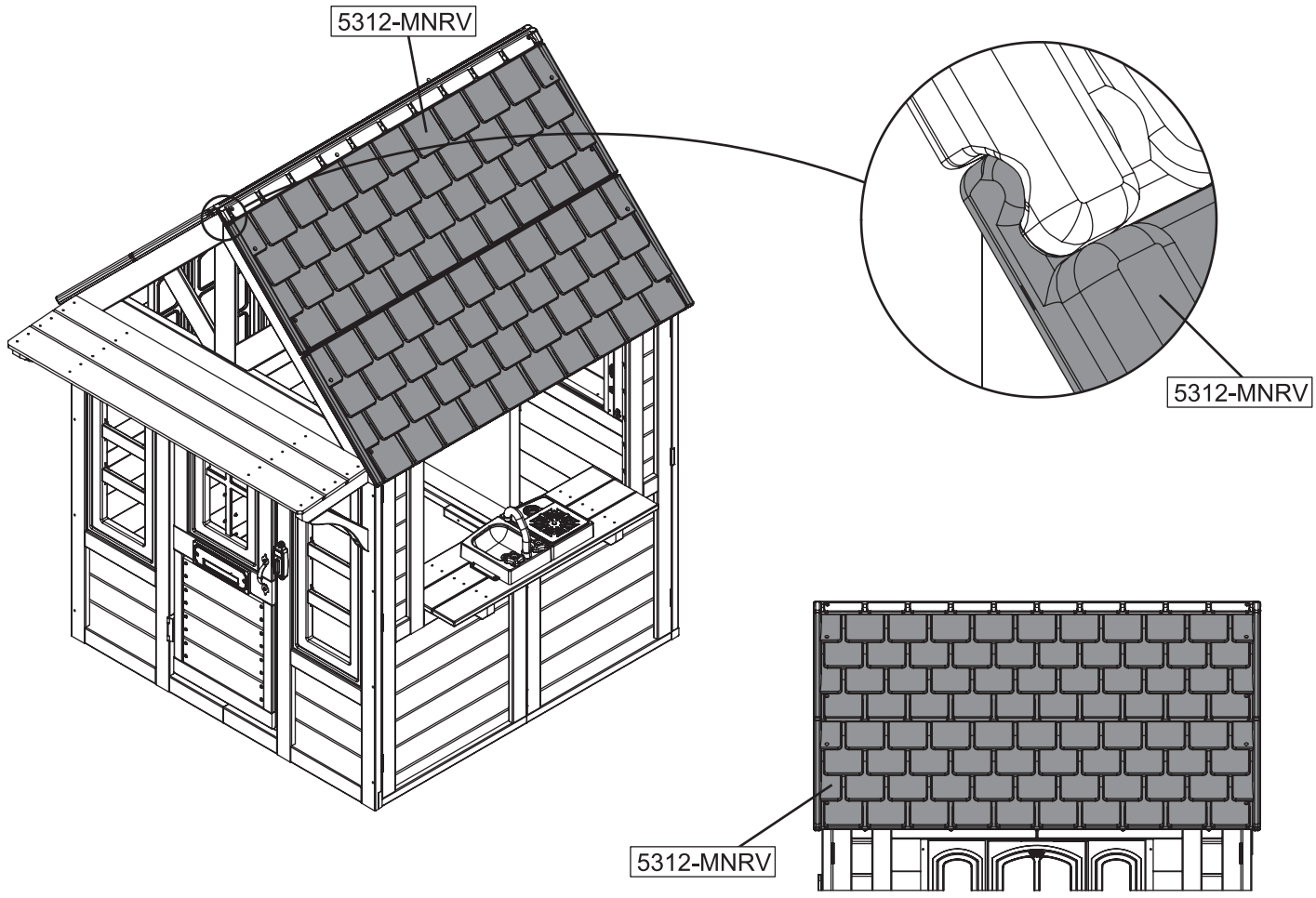

50

2 x C

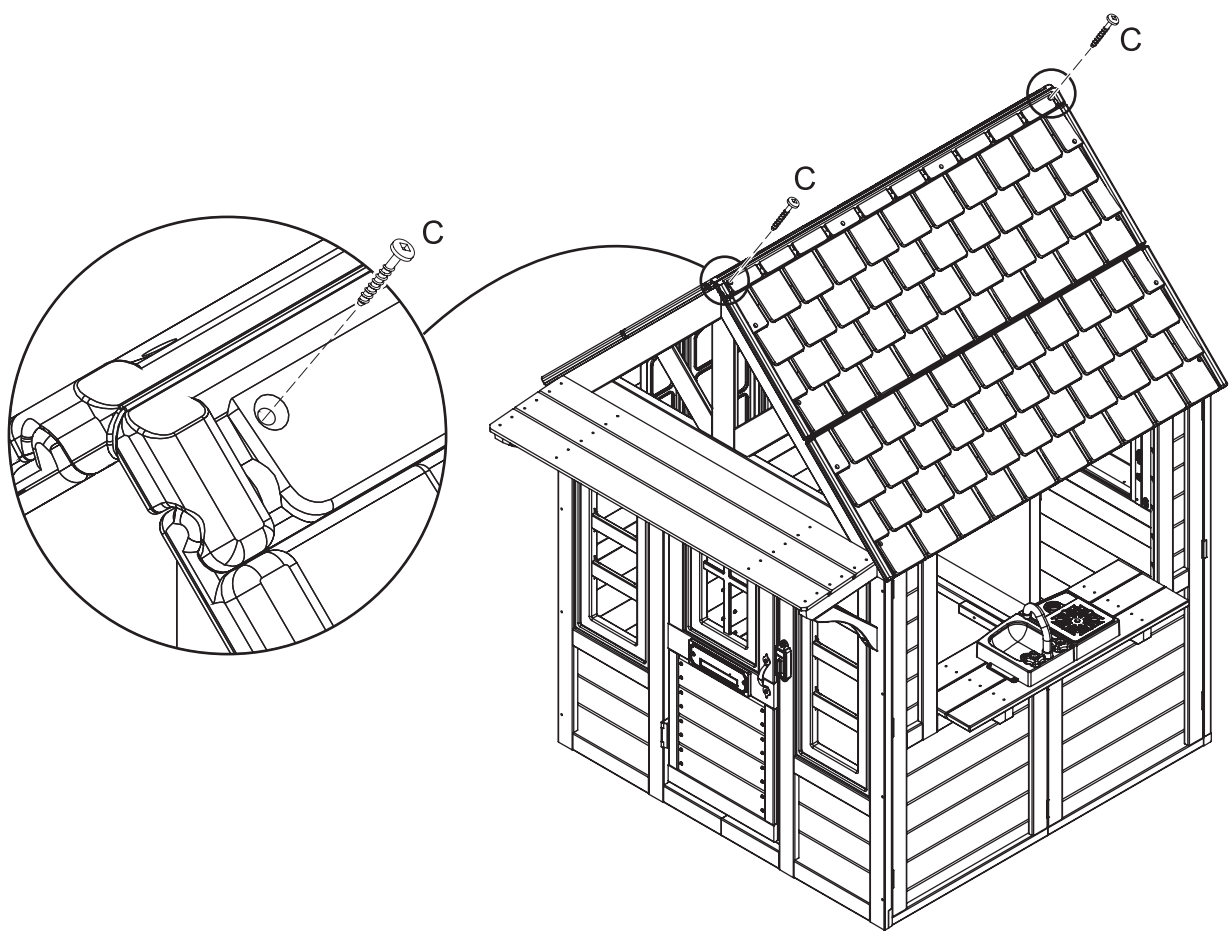

51

8 x C

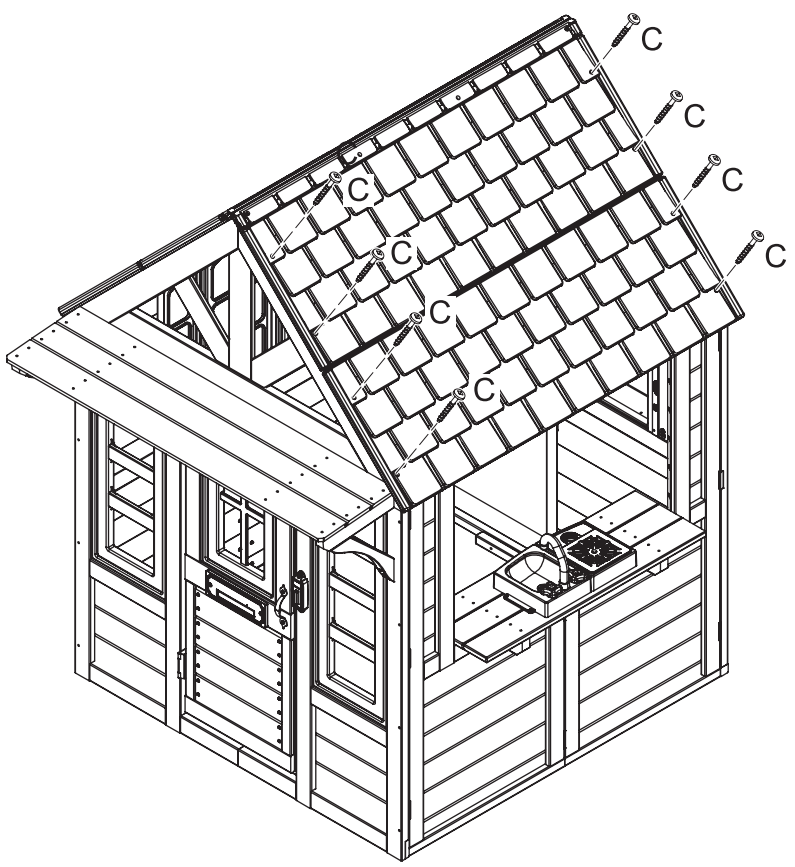

parts.kidkraft.com

customerservice@kidkraft.com  
 1.800.933.0771  
 972.385.0100

52



2 x 24

4 x C

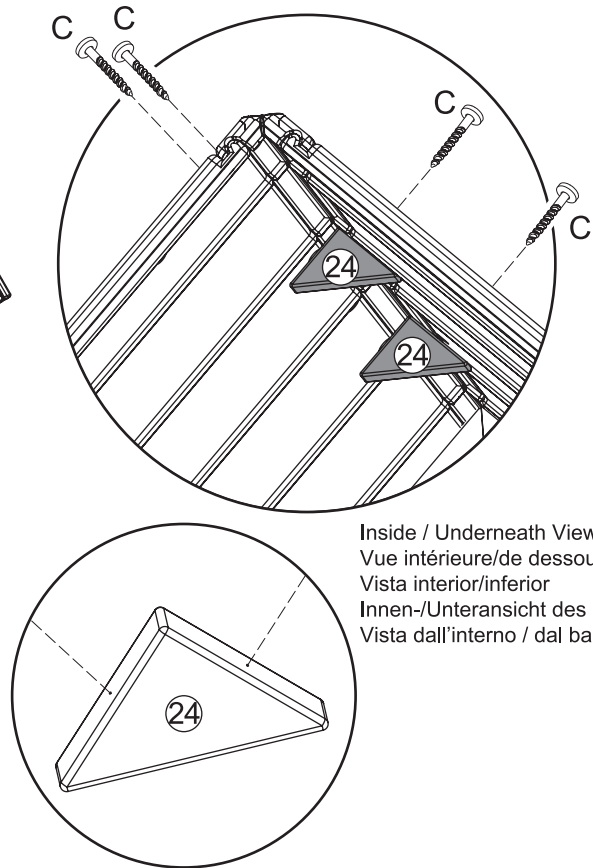
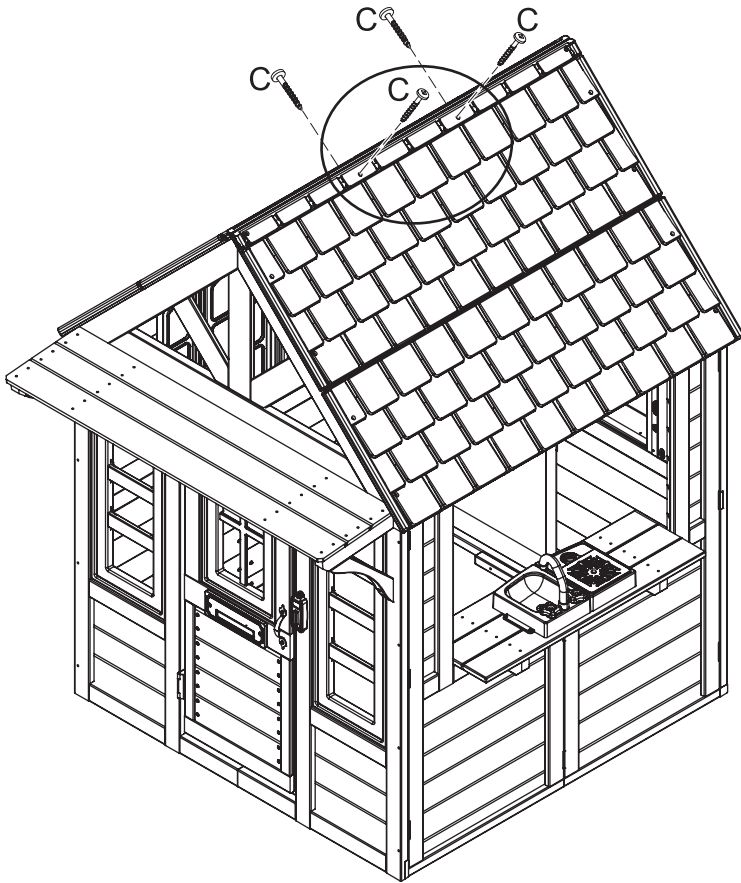

Inside / Underneath View  
Vue intérieure/de dessous  
Vista interior/inferior  
Innen-/Unteransicht des Spielhauses  
Vista dall'interno / dal basso

53

- 1 x 4450-RD
- 1 x 4451-STGY
- 1 x 4452-STGY

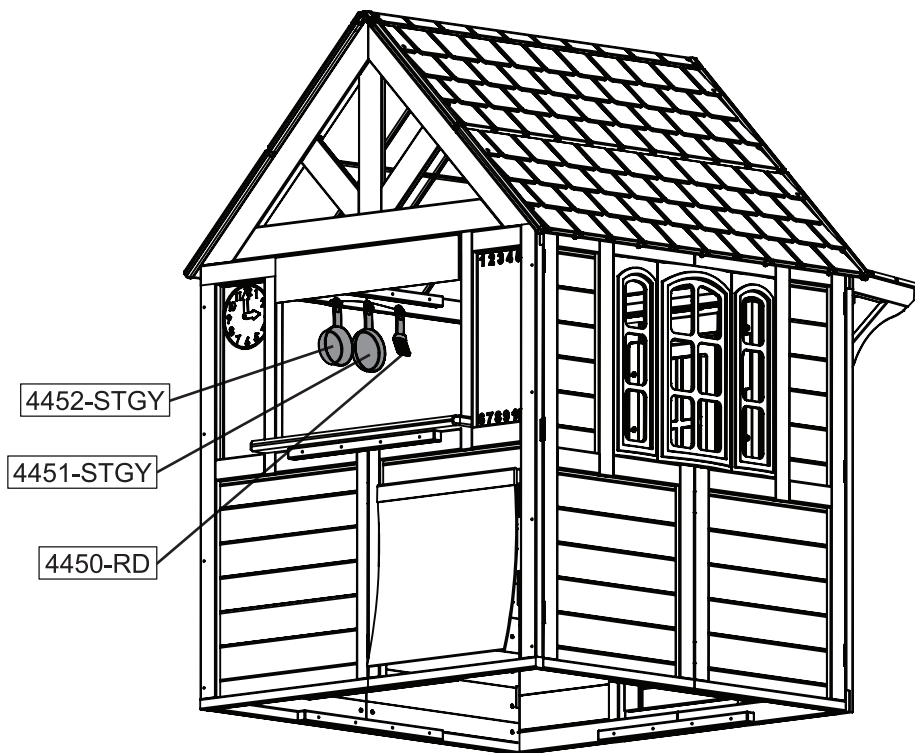

54



- 1 x 20
- 1 x 21
- 4 x G

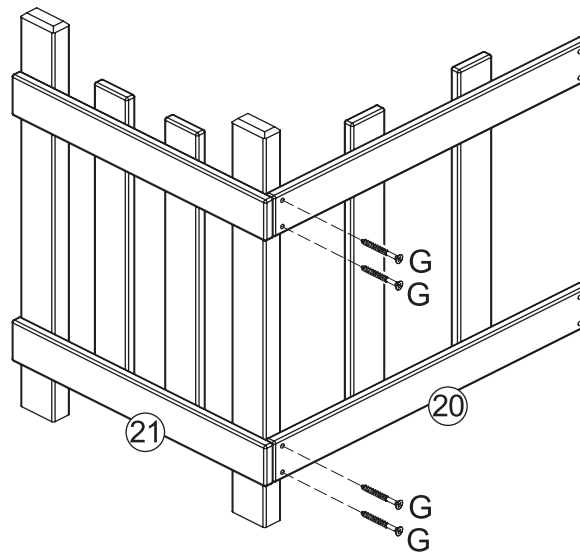

55



- 1 x 20
- 1 x 22
- 4 x G

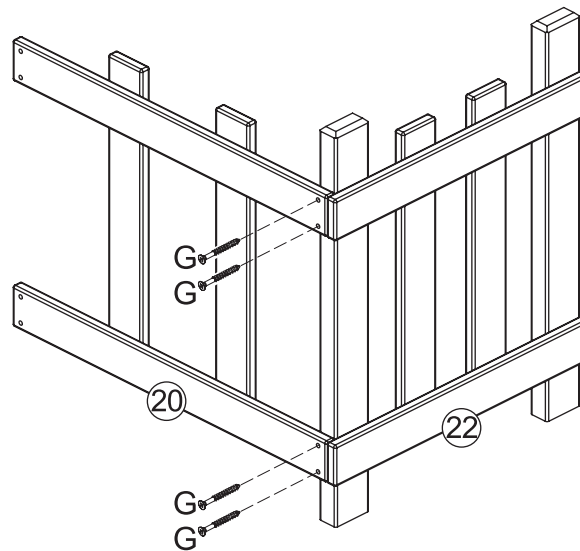



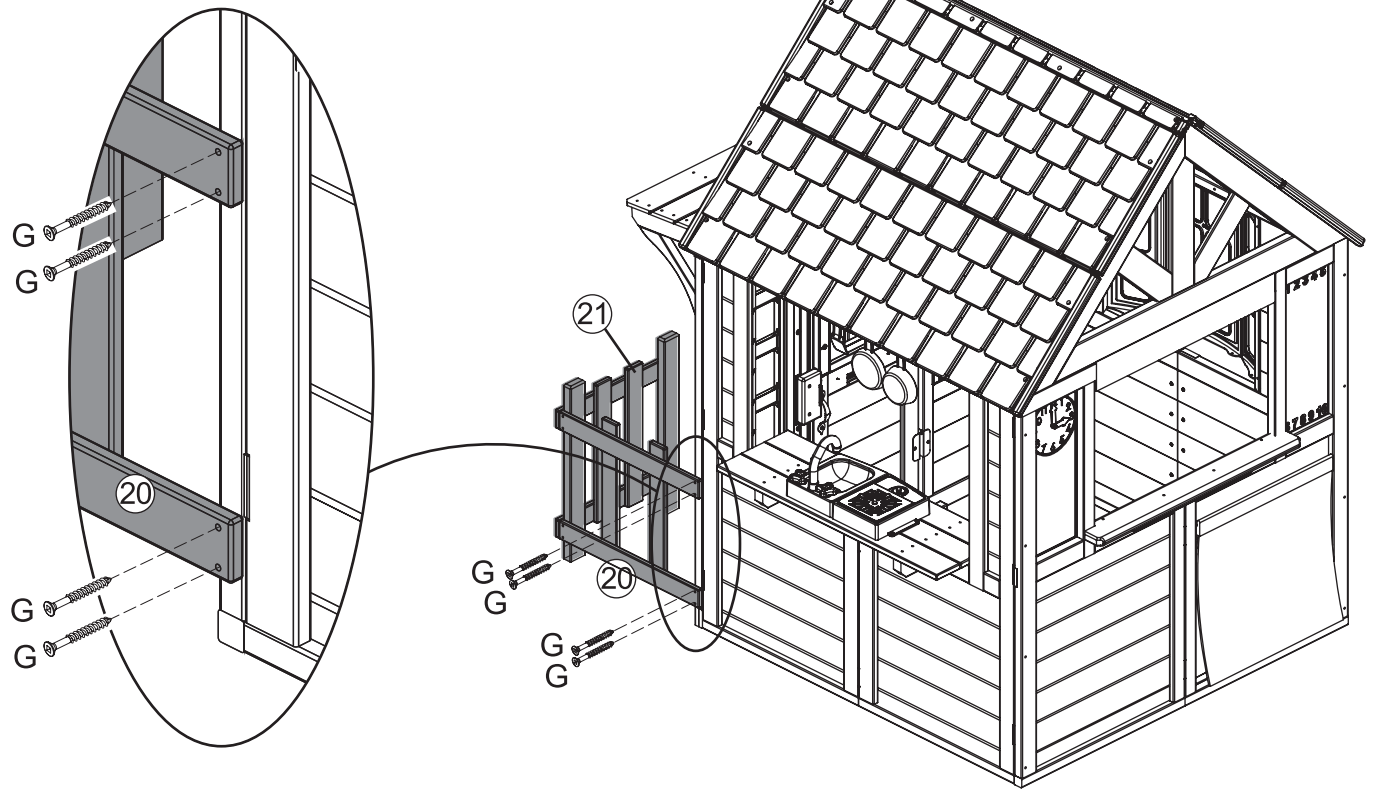
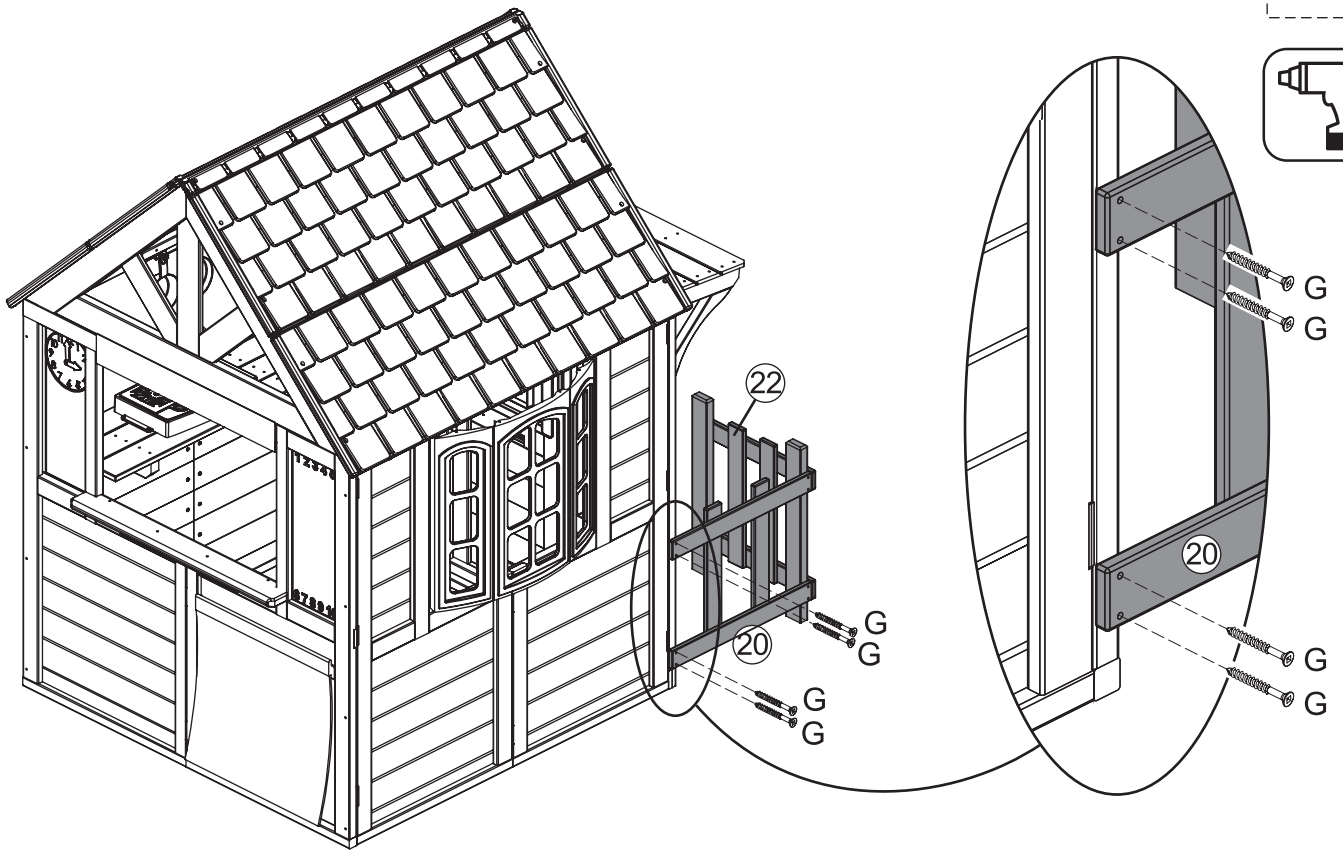

57

2 x 4448-WT

4 x C

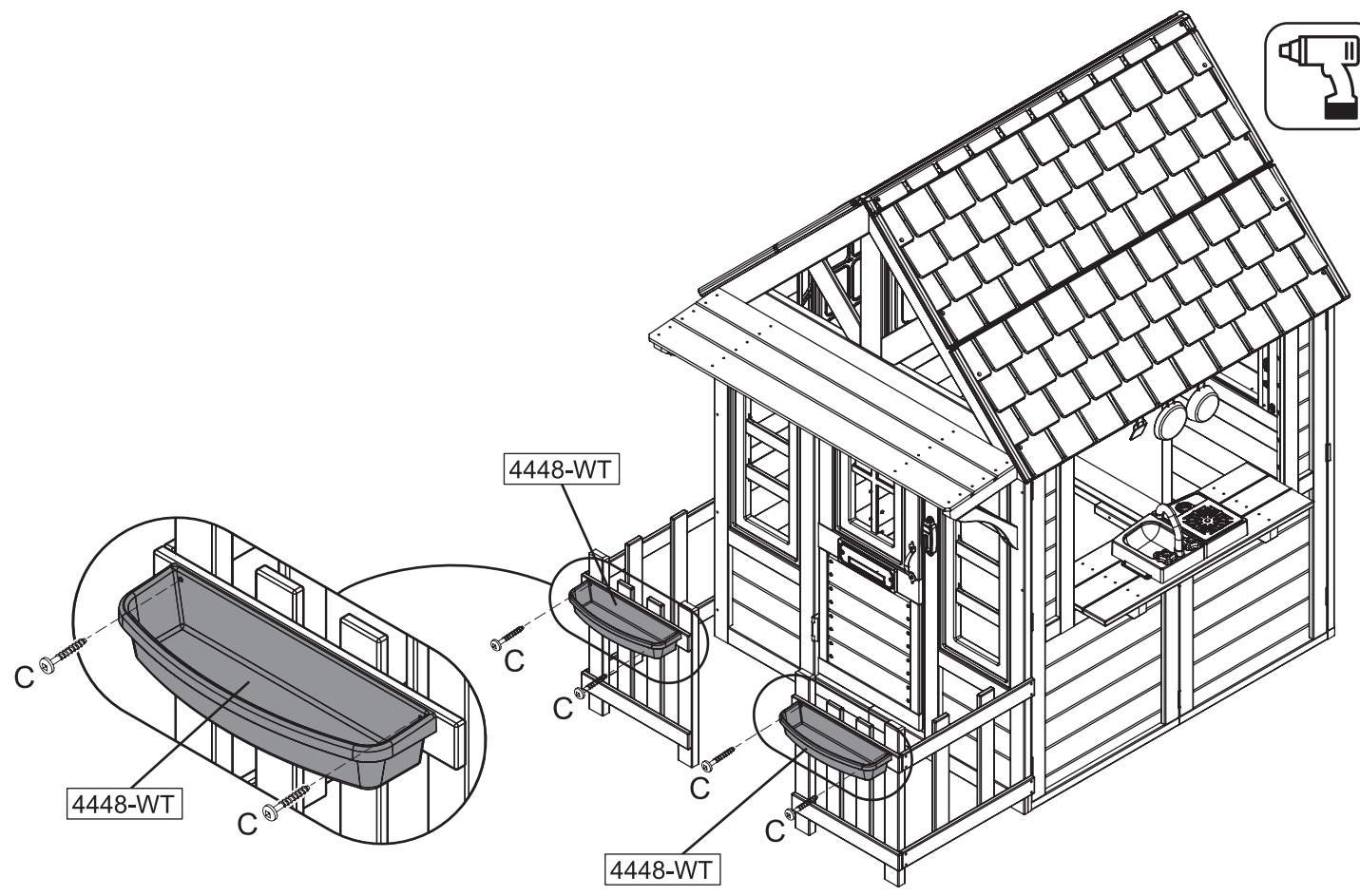

58

1 x 5280-RD-a

1 x 5280-RD-b

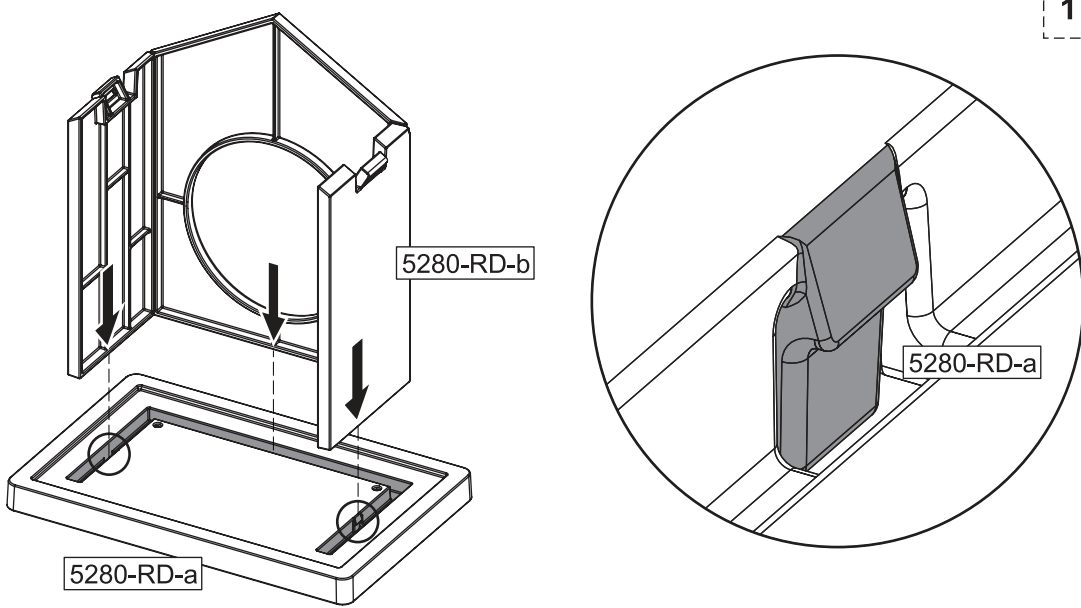

parts.kidkraft.com

customerservice@kidkraft.com  
1.800.933.0771  
972.385.0100

59

1 x 5280-RD-c

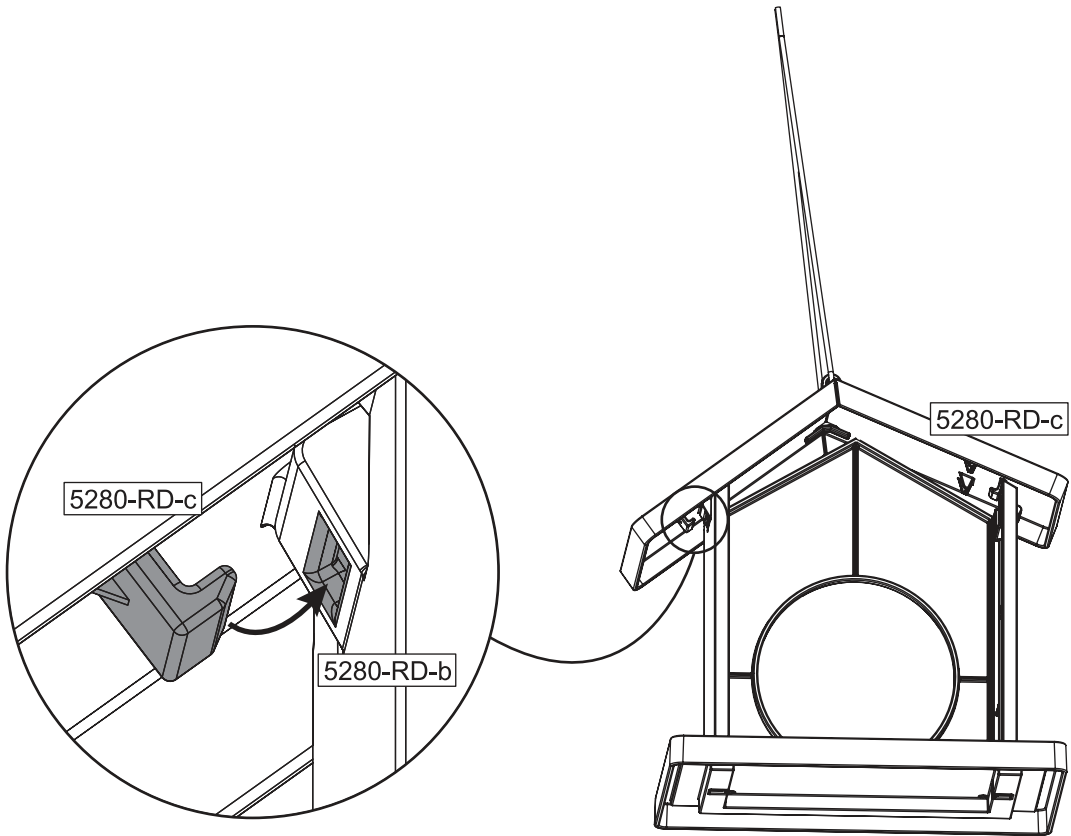

60

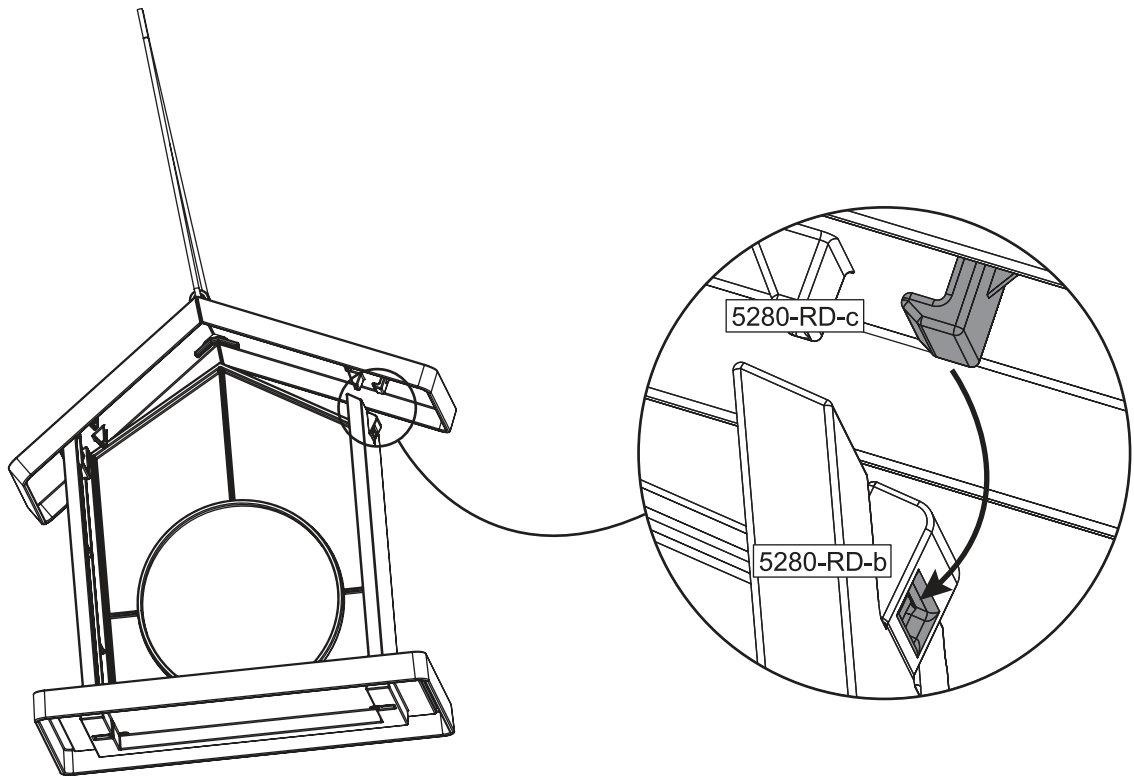

61

1 x A  
1 x D

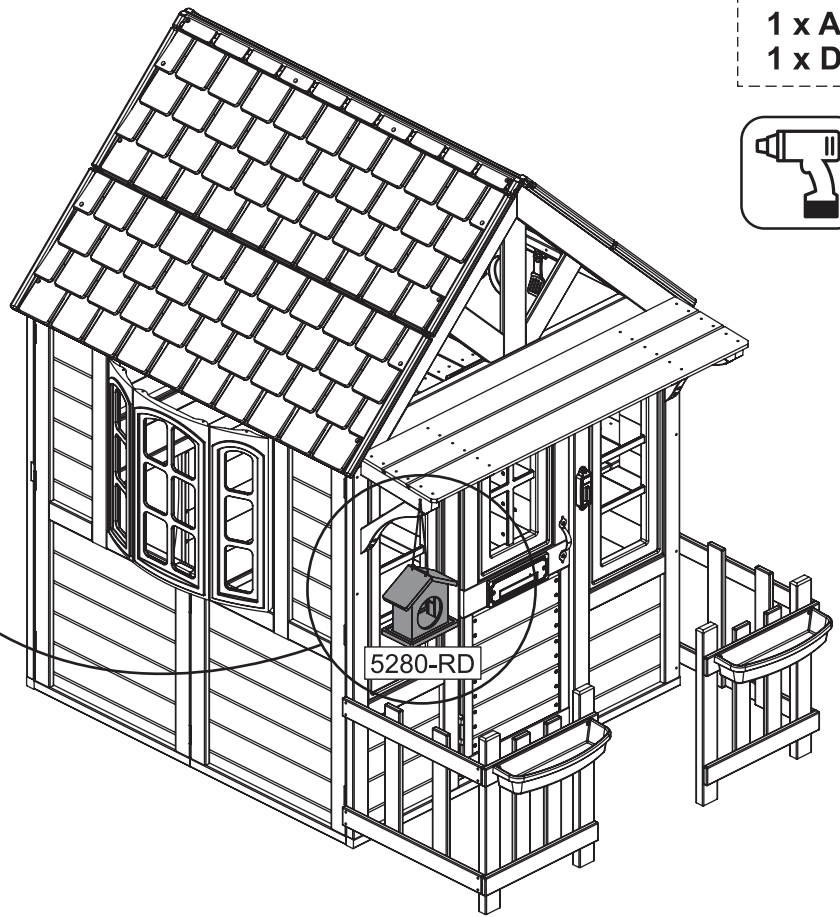
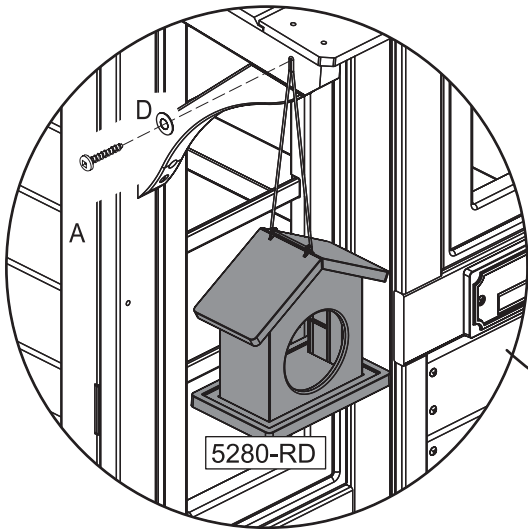

62

2 x 23

4 x G

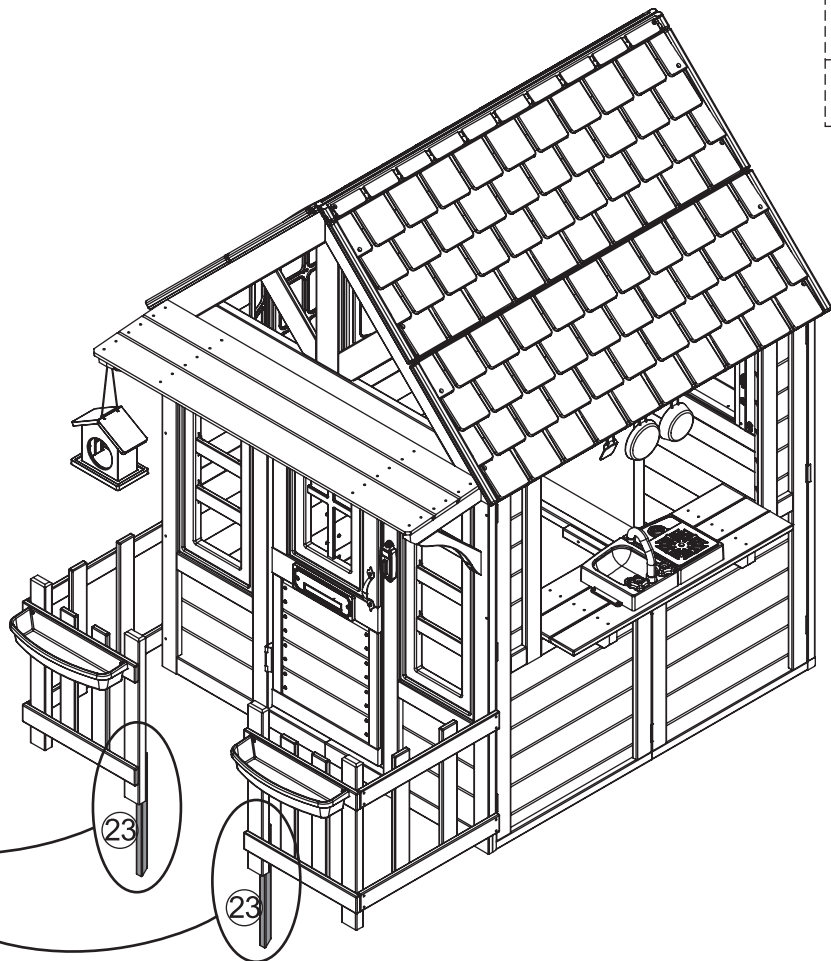
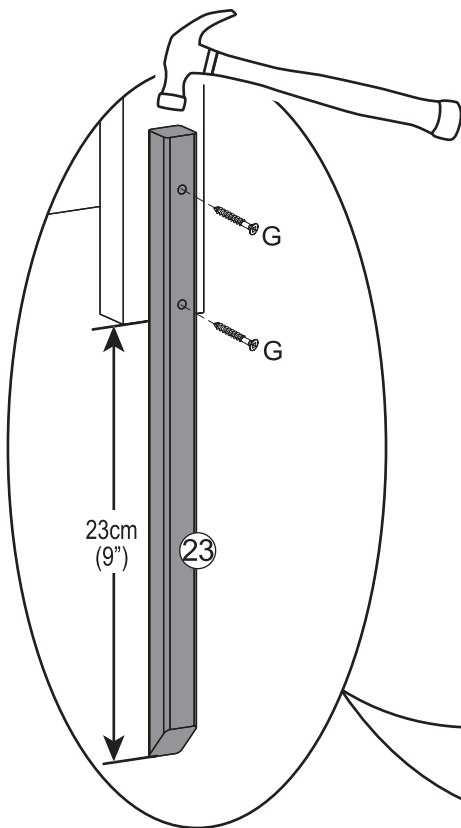

**Battery Replacement Guide**  
**Guide de remplacement de batterie**  
**Guía para cambiar las baterías**  
**Anleitung zum Ersetzen der Batterien**  
**Guida per sostituire la batteria**

**A1**

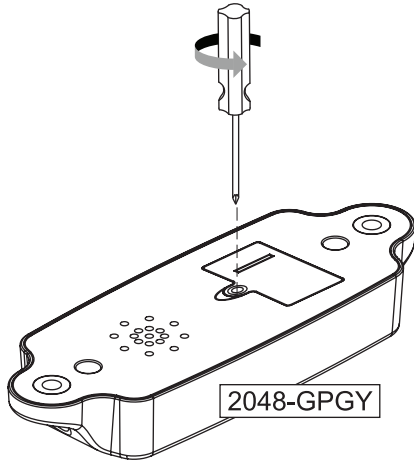

**A2**

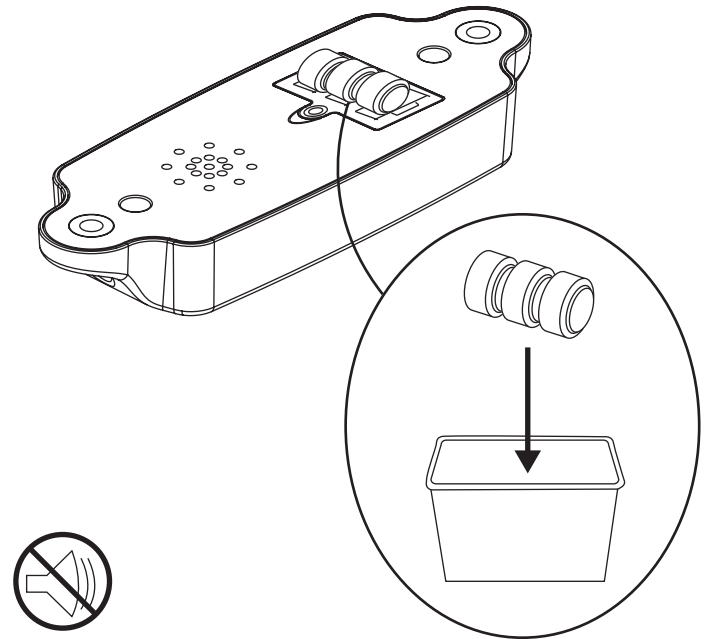

**A3**

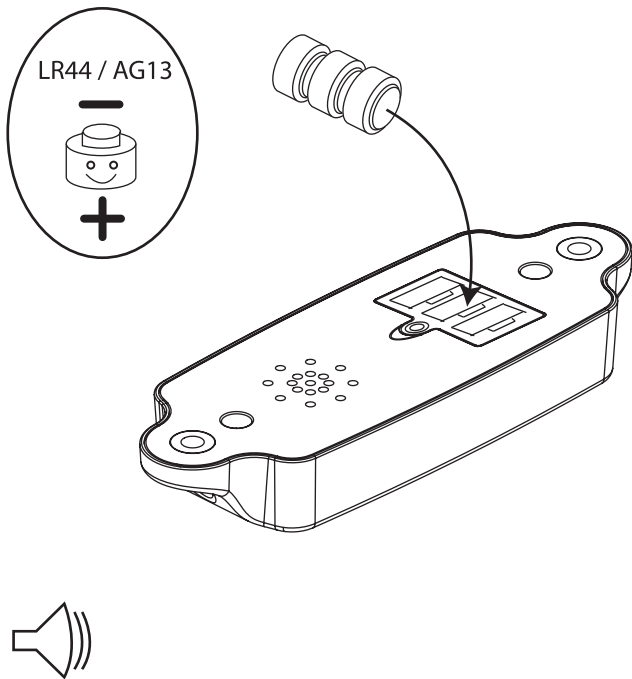

**A4**

