

Product Specifications

5.0 Gallon Round Tight Head with Swing Handle

Product Uses

Liquid Products

Product Codes

Container: **RND Series**

Description: 5.0G Round Tighthead

Features

UN Rating: 1H1/Y1.8/100
 Nominal capacity: 5.0 USG / 18.9L
 Maximum capacity: 5.3 USG / 20.1 L
 Tare weights: 2.65 lbs. / 1.2 kgs.

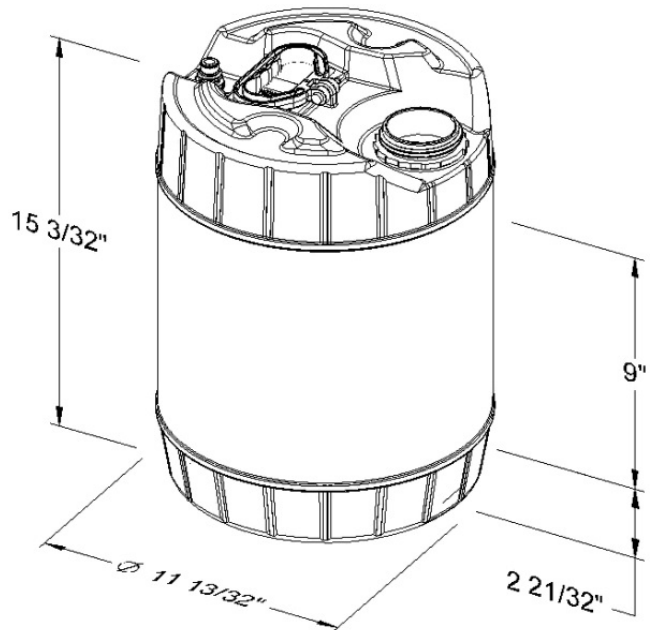

Colors

Standard: White, Black, Blue and Natural
 Custom: Available at manufacturer's discretion

Decorating Options

Maximum Label Area:
 Circumference: 35-13/16" x 8-3/4" H
 See Salesperson for Options

Shipping Data

Qty. per floor spot:
 Gross Weight (lbs./kgs)*:
 Length (in./cm.):
 Width (in./cm.):
 Height (in./cm.):

Containers

84
 227 / 103
 45.6 / 116
 34.2 / 87
 109 / 276

Filled Containers

Refer to BWAY document # ETS-CD-1002
 for storage and shipping recommendations.

Estimated truckload quantity of 2,520 containers**

Notes: *Weight does not include pallet / packaging
 **Truckload quantity based on 53' trailer

Materials

FDA approved materials
 Resin: Body: High-Density Polyethylene (HDPE)
 Handle/Pin: High-Density Polyethylene (HDPE)

Optional Carrying Handle

Swing Handle with Pin

DISTRIBUTED BY:



REF NO.:

DWG31942

DESCRIPTION:

5 Gallon HDPE Round TH Pail, with Optional Swing Handle, With Vent

DISCLAIMER

THIS INFORMATION IS PROVIDED AS A GENERAL GUIDE, INCLUDING DIMENSIONS. IT IS THE CUSTOMER'S RESPONSIBILITY TO SELECT THE PROPER CONTAINER FOR PRODUCT AND APPLICATION COMPATIBILITY.