



## Ceiling Fan Installation Manual



93099665\_D

**P250002**

# Limited Lifetime Warranty

Progress Lighting fan motors are warranted to the original purchaser to be free of electrical and/or mechanical defects for so long as the original purchaser owns the fan. Pull chain switches, reverse switches, capacitors and metal finishes are warranted to be free from defects in materials or workmanship for a period of 1 year from the date of purchase. Warping of wooden or plastic blades is not covered by this warranty nor is corrosion and/or deterioration of any finishes for fans installed within ten miles of any sea coast. Extended warranties for ENERGY STAR® qualified products may apply.

Progress Lighting ceiling fans with built-in LED light sources, when properly installed and under normal conditions of use, are warranted to be free from defects in material and workmanship which cause the light sources to fail to operate in accordance with the specifications for (i) five (5) years from the date of purchase on the LED Light modules and electrical components for fans used in single family residences, and (ii) three (3) years from the date of purchase on the LED Light modules and electrical components for fans used in multi-family or commercial applications. LED bulbs supplied by Progress Lighting carry no warranty other than manufacturer's warranty. Non-LED bulbs carry no warranty.

With proof of purchase, the original purchaser may return the defective fan to the place of purchase during the first 30 days for replacement. After 30 days, the original purchaser MUST contact Progress Lighting at (864) 678-1000 for repair or replacement which shall be determined in Progress Lighting's sole discretion and shall be purchaser's sole and exclusive remedy.

Labor and Shipping Excluded. This warranty does not cover any costs or fees associated with the labor (including, but not limited to, electrician's fees) required to install, remove, or replace a fan or any fan parts.

This warranty shall not apply to any loss or damage resulting from (i) normal wear and tear or alteration, misuse, abuse or neglect, or (ii) improper installation, operation, repair or maintenance by original purchaser or a third party, including without limitation improper voltage supply or power surge, use of improper parts or accessories, unauthorized repair (made or attempted) or failure to provide maintenance to the fan.

THE FOREGOING WARRANTIES STATE PROGRESS LIGHTING'S ENTIRE WARRANTY OBLIGATION AND ORIGINAL PURCHASER'S SOLE AND EXCLUSIVE REMEDY RELATED TO SUCH PRODUCTS. PROGRESS LIGHTING IS NOT RESPONSIBLE FOR DAMAGES (INCLUDING INDIRECT, SPECIAL, INCIDENTAL OR CONSEQUENTIAL), DUE TO PRODUCT FAILURE, WHETHER ARISING OUT OF BREACH OF WARRANTY, BREACH OF CONTRACT, OR OTHERWISE. THIS WARRANTY IS GIVEN IN LIEU OF ALL OTHER WARRANTIES, WHETHER EXPRESSED OR IMPLIED, INCLUDING THOSE OF MERCHANTABILITY, FITNESS FOR A PARTICULAR PURPOSE OR NONINFRINGEMENT.

Some states do not allow limitations on how long an implied warranty lasts or the exclusion or limitations of incidental or consequential damages, so the above limitations and exclusions may not apply to you. This warranty gives you specific rights and you may have other rights which vary from state to state.

Date Purchased \_\_\_\_\_

Store Purchased \_\_\_\_\_

Model No. \_\_\_\_\_

Serial No. \_\_\_\_\_

Vendor No. \_\_\_\_\_ 109226

785247230464

785247230471

UPC  785247230488



Safety Rules.....	1.
Unpacking Your Fan .....	2.
Installing Your Fan .....	3.
Installing the Light Kit.....	9.
Installing the Fan without the Light Kit (optional) .....	10.
Operating Your Transmitter .....	12.
Care of Your Fan .....	13.
Troubleshooting .....	14.
Specifications .....	15.

## *Table of Contents*

1. To reduce the risk of electric shock, insure electricity has been turned off at the circuit breaker or fuse box before beginning.
2. All wiring must be in accordance with the National Electrical Code and local electrical codes. Electrical installation should be performed by a qualified licensed electrician.
3. **WARNING:** To reduce the risk of electrical shock and fire, do not use this fan with any solid-state fan speed control device.
4. **WARNING:** To reduce the risk of fire, electric shock, or personal injury, mount to outlet box marked "Acceptable for Fan Support of 15.9 kg (35 lbs.) Or Less" and use mounting screws provided with the outlet box. Most outlet boxes commonly used for the support of light fixtures are not acceptable for fan support and may need to be replaced. Due to the complexity of the installation of this fan, a qualified licensed electrician is strongly recommended.
9. To avoid personal injury or damage to the fan and other items, be cautious when working around or cleaning the fan.
10. Do not use water or detergents when cleaning the fan or fan blades. A dry dust cloth or lightly dampened cloth will be suitable for most cleaning.
11. After making electrical connections, spliced conductors should be turned upward and pushed carefully up into the outlet box. The wires should be spread apart with the grounded conductor and the equipment-grounding conductor on one side of the outlet box.
12. Electrical diagrams are for reference only. Light kits that are not packed with the fan must be cUL Listed and marked suitable for use with the model fan you are installing. Switches must be cUL General Use Switches. Refer to the Instructions packaged with the light kits

**WARNING**

TO REDUCE THE RISK OF FIRE, ELECTRIC SHOCK OR PERSONAL INJURY, MOUNT FAN TO OUTLET BOX MARKED ACCEPTABLE FOR FAN SUPPORT.

**WARNING**

TO REDUCE THE RISK OF PERSONAL INJURY, DO NOT BEND THE BLADE ARMS (ALSO REFERRED TO AS BRACKETS) DURING ASSEMBLY OR AFTER INSTALLATION. DO NOT INSERT OBJECTS IN THE PATH OF THE BLADES.

5. The outlet box and support structure must be securely mounted and capable of reliably supporting a minimum of 35 lbs (15.9 kg) or less. Use only cUL-listed outlet boxes marked **FOR FAN SUPPORT**.
6. The fan must be mounted with a minimum of 7 ft (2.1m) clearance from the trailing edge of the blades to the floor.
7. To operate the reverse function on this fan, press the reversing button while the fan is running.
8. Avoid placing objects in the path of the blades.

**NOTE**

READ AND SAVE ALL INSTRUCTIONS!

# *1. Safety Rules*

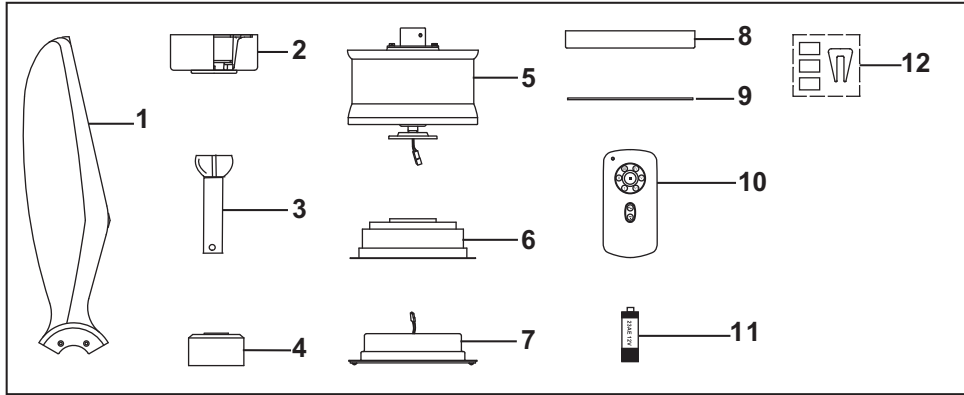

Unpack your fan and check the contents. You should have the following items:

- |                          |                                   |
|--------------------------|-----------------------------------|
| 1. Fan blades (3)        | 7. 18 Watt LED light kit assembly |
| 2. Canopy assembly       | 8. Decorative ring                |
| 3. Ball/downrod assembly | 9. Metal light cover              |
| 4. Coupling cover        | 10. Remote control                |
| 5. Fan motor assembly    | 11. 12V MN21/A23 battery          |
| 6. Mounting plate        | 12. Balancing kit                 |

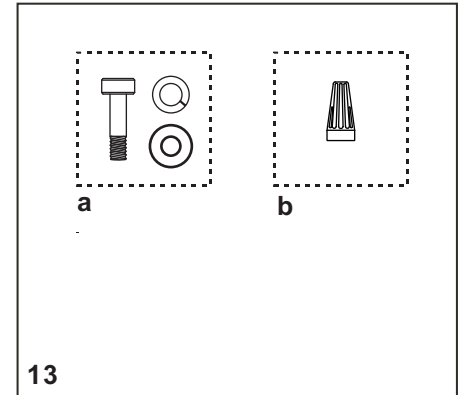

13

13. Loose parts bag containing:
- a. Blade attachment hardware**  
(7 screws, 7 lock washers,  
7 flat washers)
  - b. Mounting hardware**  
Wire nuts (3)

## *Unpacking Your Fan 2.*

## Tools Required

Phillips screw driver, straight slot screw driver, adjustable wrench, step ladder, and wire cutters.

## Mounting Options

If there isn't an existing cUL listed mounting box, then read the following instructions. Disconnect the power by removing fuses or turning off circuit breakers.

Secure the outlet box directly to the building structure. Use appropriate fasteners and building materials. The outlet box and its support must be able to fully support the moving weight of the fan (at least 35 lbs). Do not use plastic outlet boxes.

### WARNING

TO REDUCE THE RISK OF FIRE, ELECTRIC SHOCK, OR OTHER PERSONAL INJURY, MOUNT FAN ONLY TO AN OUTLET BOX MARKED ACCEPTABLE FOR FAN SUPPORT AND USE THE MOUNTING SCREWS PROVIDED WITH THE OUTLET BOX. OUTLET BOXES COMMONLY USED FOR THE SUPPORT OF LIGHTING FIXTURES MAY NOT BE ACCEPTABLE FOR FAN SUPPORT AND MAY NEED TO BE REPLACED. CONSULT A QUALIFIED ELECTRICIAN IF IN DOUBT.

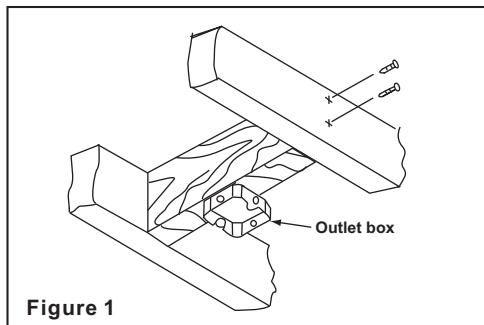

Figure 1

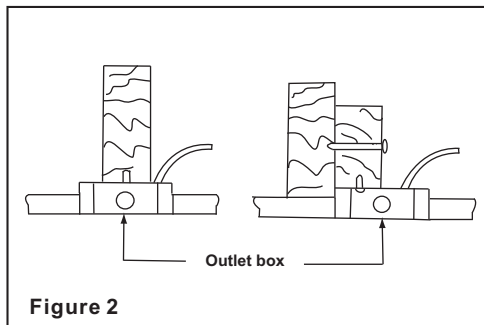

Figure 2

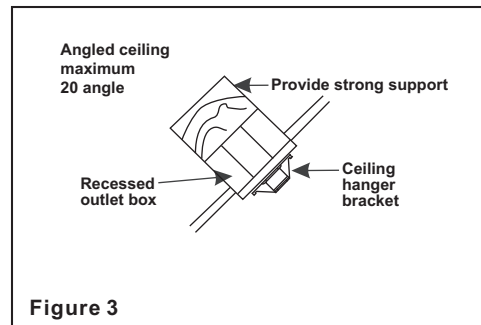

Figure 3

**Note:** You may need a longer downrod to maintain proper blade clearance when installing on a steep, sloped ceiling.

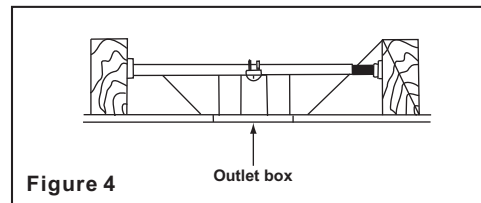

Figure 4

To hang your fan where there is an existing fixture but no ceiling joist, you may need an installation hanger bar as shown in Figure 4 (available at your Progress Lighting Retailer).

# 3. Installing Your Fan

## Hanging the Fan

**REMEMBER** to turn off the power. Follow the steps below to hang your fan properly:

**Step 1.** Remove the decorative canopy bottom cover from the canopy by turning the cover counter clockwise.(Fig. 5)

**Step 2.** Remove the mounting bracket from the canopy by removing the 1 of 2 screws from the bottom of the mounting bracket and loosening the other one a half turn from the screw head. Next, turn the canopy counter clockwise to removing the mounting bracket from the canopy. (Fig. 5)

**Step 3.** Pass the 120-volt supply wires through the center hole in the ceiling hanger bracket as shown in Fig. 6.

**Step 4.** Secure the hanger bracket to the ceiling outlet box with the screws and washers provided with your outlet box.

**Step 5.** Remove the hanger pin, lock pin and set screws from the top of the motor assembly. (Fig. 7)

**Step 6.** Route the safety cable and wires exiting from the top of the fan motor through the collar cover, canopy cover, canopy and then through the ball / downrod. (Fig. 7)

**Step 7.** Align the holes at the bottom of the downrod with the holes in the collar on top of the motor housing (Fig. 7). Carefully insert

the hanger pin through the holes in the collar and downrod. Be careful not to jam the pin against the wiring inside the downrod. Insert the locking pin through the hole near the end of the hanger pin until it snaps into its locked position, as noted in the circle inset of Fig. 7.

**WARNING**  
FAILURE TO PROPERLY INSTALL  
LOCKING PIN AS NOTED IN STEP 7  
COULD RESULT IN FAN LOOSENING AND  
POSSIBLY FALLING.

**Step 8.** Tighten two set screws on top of the fan motor firmly. (Fig. 7)

**Step 9.** Place the downrod ball into the hanger bracket socket.

**Step 10.** Secure the safety cable to the building structure with a wood screw. (wood screw not supplied)

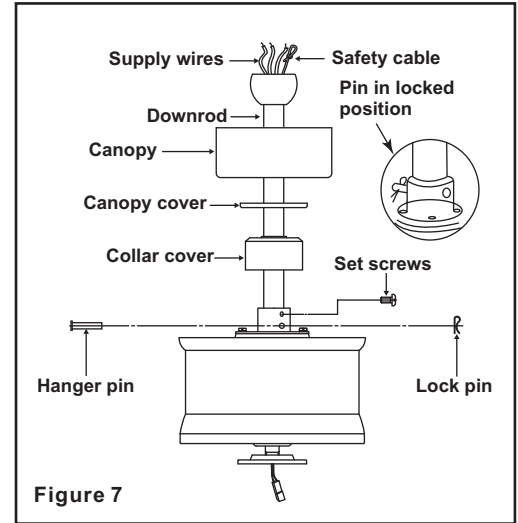
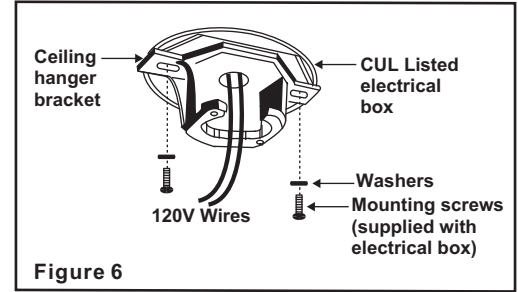
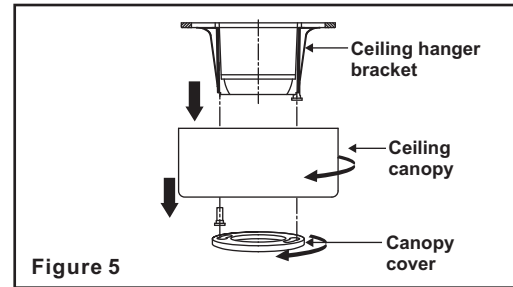

# Make the Electric Connections

**WARNING:** To avoid possible electrical shock, be sure electricity is turned off at the main fuse box before wiring.

**Step 1.** Motor to House Supply Wires Electrical Connections: Connect the WHITE wire (Neutral) from the outlet box to the WHITE wire marked "AC in N" from the motor. (Fig. 8)

**Step 2.** Connect the BLACK wire (Hot) from the outlet box to the BLACK wire marked "AC in L" from the motor. (Fig. 8)

Secure all wire connections with the plastic wire nuts provided.

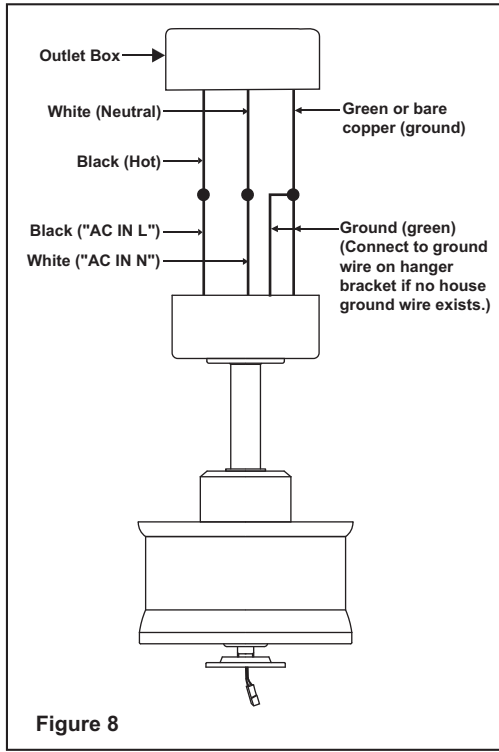

## Finishing the Installation

**Step 1.** Tuck connections neatly into ceiling outlet box.

**Step 2.** Slide the canopy up to mounting bracket and place the key hole on the canopy over the screw on the mounting bracket, turn canopy until it locks in place at the narrow section of the key holes. (Fig. 9)

**Step 3.** Align the circular hole on canopy with the remaining hole on the mounting bracket, secure by tightening the two set screws. Note: Adjust the canopy screws as necessary until the canopy and canopy cover are snug.

### WARNING

Make sure the notch on the hanging bracket properly sits in the groove in the hanger ball before attaching the canopy to the bracket by turning the housing until it drops into place.

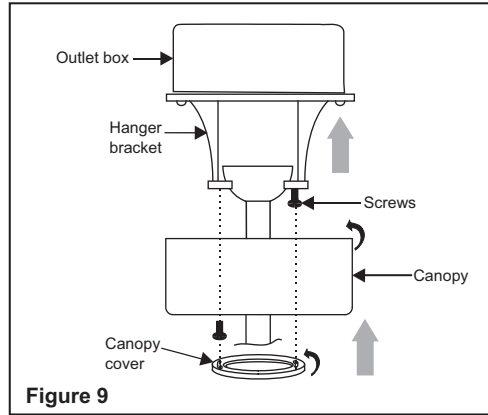

# Attaching the Fan Blades

Fasten the blade assembly to the motor using the screws, lock washers and flat washers provided. Be sure to tighten all screws. (Figure 10)

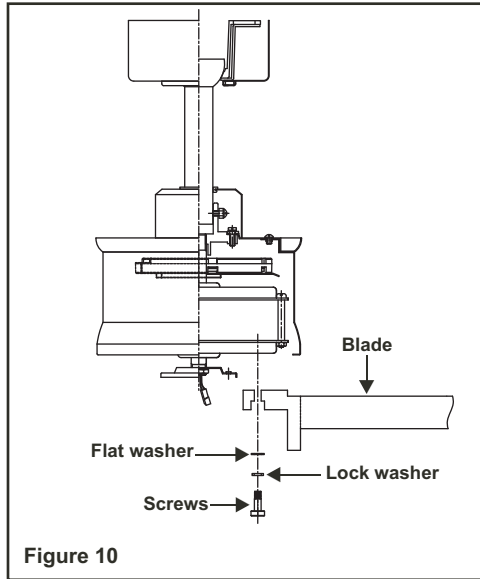

# Blade Balancing

All blades are grouped by weight. Because natural woods vary in density, the fan may wobble even though the blades are weighed equally.

The following procedure should correct most fan wobbling problems. Check after each step.

1. Check that all blade and blade arm screws are secure.
2. Most fan wobbling problems are caused when blade levels are unequal. Check this level by selecting a point on the ceiling above the tip of one of the blades. Measure this distance as shown in Figure 11. Rotate the fan until the next blade is positioned for measurement. Repeat for each blade. The distance deviation should be equal within 1/8".
3. Use the enclosed Blade Balancing Kit if the blade wobble is still noticeable.
4. If the blade wobble is still noticeable, interchanging two adjacent (side by side) blades can redistribute the weight and possibly result in smoother operation.

**WARNING**  
TO REDUCE THE RISK OF PERSONAL INJURY, DO NOT BEND THE BLADE HOLDERS WHILE INSTALLING, BALANCING THE BLADES, OR CLEANING THE FAN. DO NOT INSERT FOREIGN OBJECTS BETWEEN ROTATING FAN BLADES.

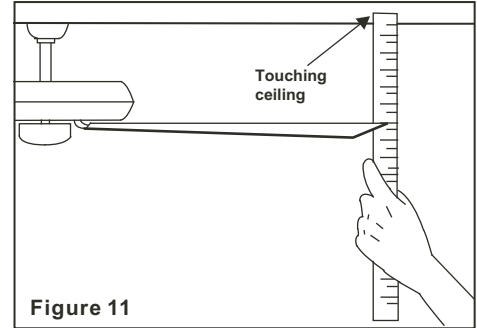

# Installing the Mounting Plate

Step 1. Remove 1 of the 3 screws from the mounting ring and loosen the other 2 screws. (Do not remove)

Step 2. Place the key holes on the mounting plate over the 2 screws previously loosened from the mounting ring, turn mounting plate until it locks in place at the narrow section of the key holes. Secure by tightening the 2 screws previously loosened and the one previously removed. (Fig. 12)

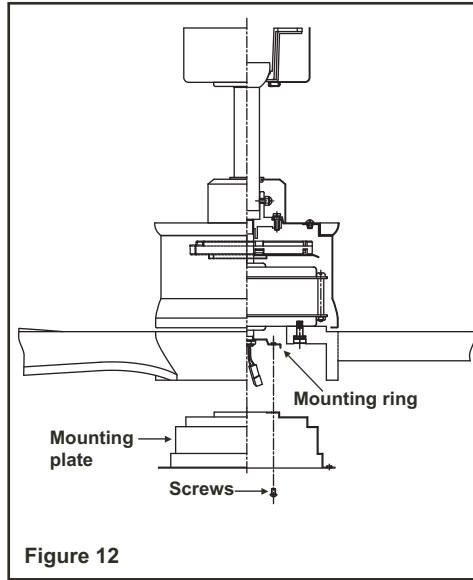

**CAUTION:** Before starting installation, disconnect the power by turning off the circuit breaker or removing the fuse at fuse box. Turning power off using the fan switch is not sufficient to prevent electric shock.

**NOTE:** If you do not wish to install the light kit, skip steps 9 and proceed to step 10.

1. Remove the 2 screws from the mounting plate.
2. While holding the LED light kit under the fan motor assembly, make the 2-pin wire connections: (Fig. 13)
  - White to white
  - Black to blue
3. Place the LED light kit to the mounting plate. Align the mounting holes with the holes in the light kit and mounting plate, and fasten using the two screws previously removed. (Fig. 13)

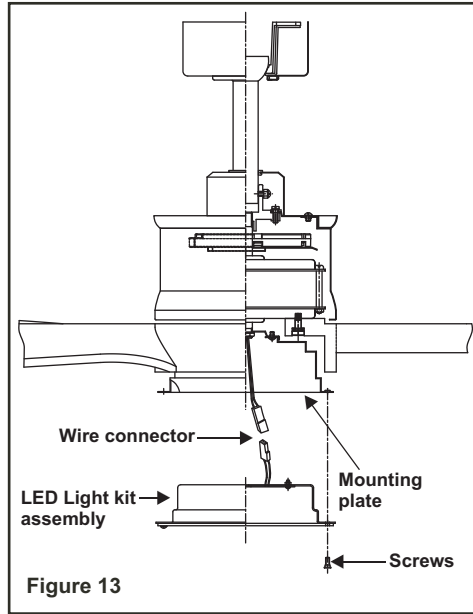

4. Slide the decorative ring up to light kit assembly and place the key hole on the decorative ring over the two screw on the light kit, turn decorative ring until it locks in place at the narrow section of the key holes. (Fig. 14)

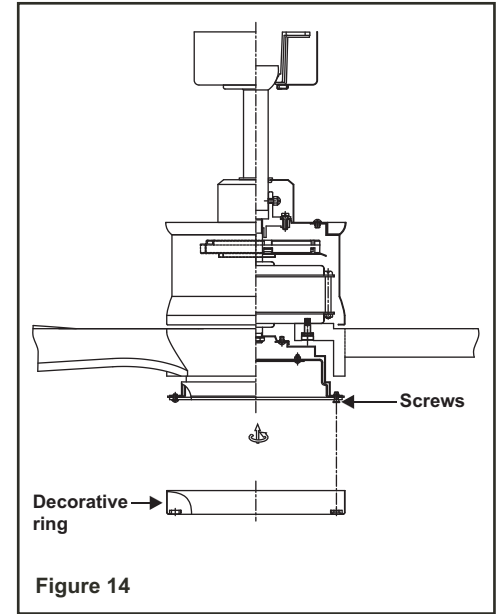

## *9. Installing the Light Kit*

**NOTE:** The metal light cover included with your fan is an option to replace the plastic shade for the light in the event that you prefer not to use the light feature of your fan.

1. Disassemble the plastic shade from the LED light kit. You can keep the plastic shade for future use. (Fig. 15)

2. Installing metal light cover to the LED light kit with the two screws previously removed. (Fig. 15)

3. Remove the 2 screws from the mounting plate. (Fig. 16)

4. Place the LED light kit to the mounting plate. Align the mounting holes with the holes in the light kit and mounting plate, and fasten using the two screws previously removed. (Fig. 16)

5. Slide the decorative ring up to light kit assembly and place the key hole on the decorative ring over the two screw on the light kit, turn decorative ring until it locks in place at the narrow section of the key holes. (Fig. 16)

**NOTE:** Do Not connect the 2-pin wire connectors before installing the metal light cover.

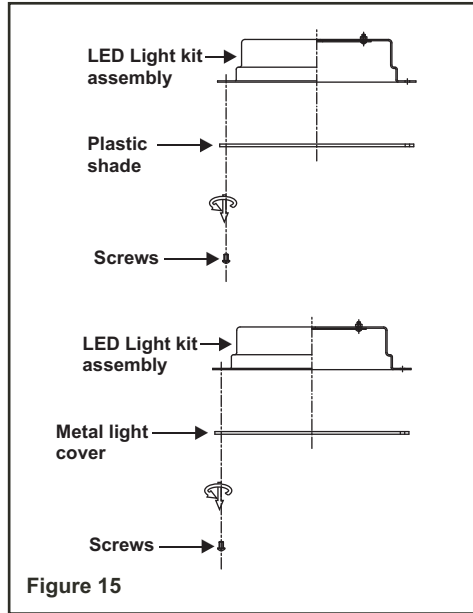

Figure 15

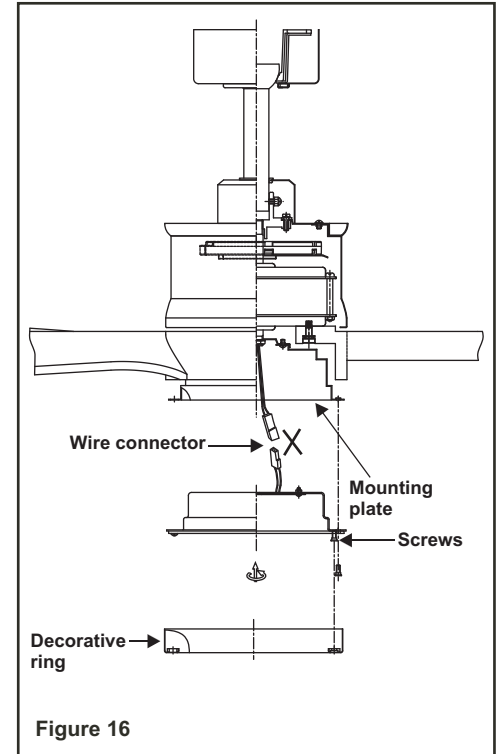

Figure 16

*Installing the Fan without the Light Kit (optional) 10.*

## Installing the battery

Install a 12V MN21/A23 battery (included) into the remote control. To prevent damage to the remote control, remove the battery if not used for long periods. (Fig. 17)

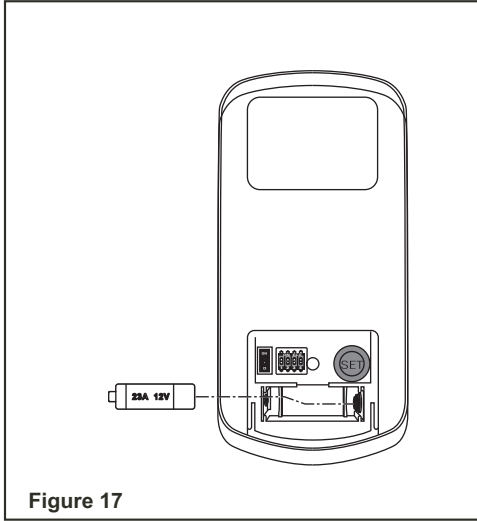

Figure 17

### Remote Control Button Definitions:

These six buttons are used to set the fan speed as follows:

I = minimum speed

II = low speed

III = medium low speed

IV = medium speed

V = medium high speed

VI = high speed

■ button: Turns the fan off.

⊙ button: Controls fan direction.

☀ button: Controls light. Switch the “D” and “ON” dip switch on the back of transmitter to decide the light in “ON/OFF” or “Dimmable” condition.

Your DC brushless motor is equipped with an automatically learned type remote control. There are no frequency switches on the receiver; the receiver unit will automatically scan the frequency from the remote control if any changes are made. The frequency settings on the transmitter should be changed **ONLY in case of interference or if a second or more ceiling fans with the same type of control system are installed in the same structure.**

### Setting the Remote Control

Follow the below steps to set the remote control:

The auto learning function will only mandate within 60 seconds when turning the fan’s AC power ON.

a) Select desired frequency from the transmitter. The dip switches can be set to 16 different combinations. (Fig. 19)

b) From the back of the transmitter, with the fan’s power off, restore power to the fan. Press and hold “SET” button for about 5 seconds and release. If optional light kit is installed, the light kit will flash twice and the signal light on the hand held transmitter will come on when the button is pressed. The fan has completed the pairing process with the remote control and is ready for use. (Fig. 19)

**NOTE:** If the self calibration test failed, turn the AC power off; restore power and process the self calibration test again.

**NOTE:** During self calibration test, the remote is non-functional.

**NOTE:** The learning frequency function and self calibration test will continue to retain the last set frequency and calibration set even when the AC power is shut off. If the frequency is changed the self calibration test will occur again.

“D” and “ON” dip switch:

1. The “ON” selection is the light dimmable selection and is to be used with all bulbs except for CFL bulbs. The “D” selection is the light ON only (no dimming function) and is to be used with CFL bulbs as CFL bulbs in most cases cannot be used with dimming controllers. (Fig. 19)

# 11. Operating Your Transmitter

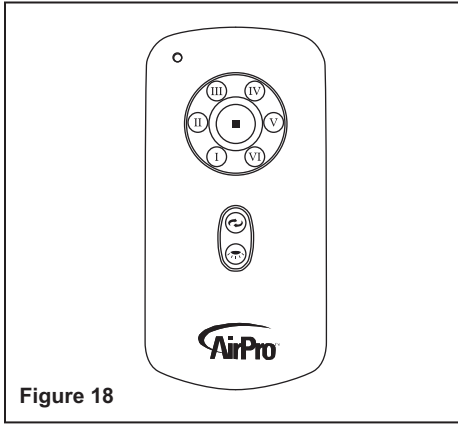

Figure 18

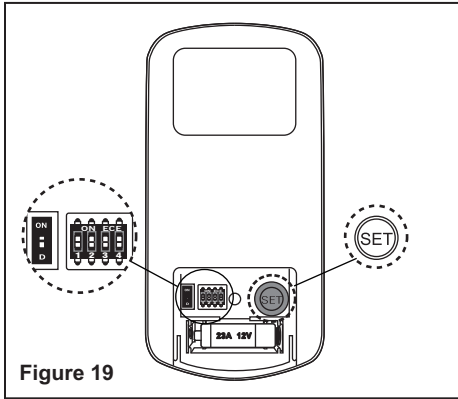

Figure 19

This receiver provides the following protective function:

1. Lock Rotor Position: The DC motor has a built-in safety against a stalled or locked rotor condition (stalled blade rotation). If there is an obstruction or fault with the motor, the current monitoring function will automatically turn power off to the motor after 30 seconds. Remove the obstruction and turn the AC power off. Restore power and re-start fan motor.
2. Over 80W protection: When the receiver detects motor power consumption which is greater than 80W, the receiver power will be stopped and operation will immediately discontinue. Wait for 5 seconds and then turn the receiver power back on.

Speed settings for warm or cool weather depend on factors such as the room size, ceiling height, number of fans and so on.

**NOTE:** To operate the reverse function on this fan, press the reverse button while the fan is running.

Warm weather - (Forward) A downward airflow creates a cooling effect as shown in Fig. 20. This allows you to set your air conditioner on a warmer setting without affecting your comfort.

Cool weather - (Reverse) An upward airflow moves warm air off the ceiling area as shown in Fig. 21. This allows you to set your heating unit on a cooler setting without affecting your comfort.

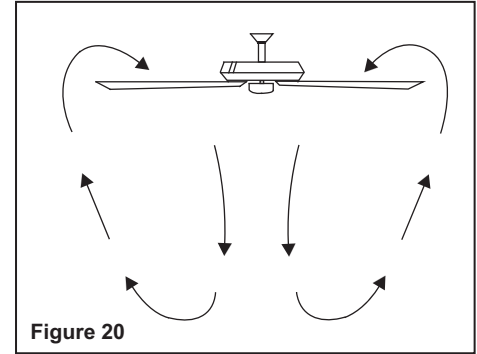

Figure 20

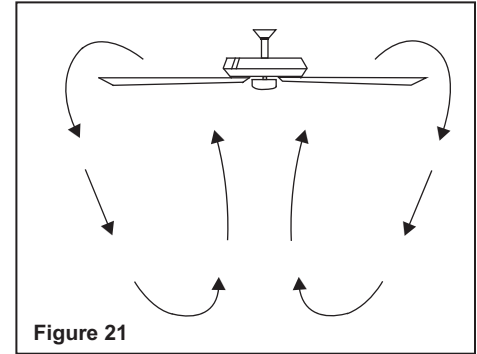

Figure 21

Here are some suggestions to help you maintain your fan

1. Because of the fan's natural movement, some connections may become loose. **Check the support connections, brackets, and blade attachments twice a year.** Make sure they are secure. **(It is not necessary to remove fan from ceiling.)**

2. Clean your fan periodically to help maintain its new appearance over the years. Use only a soft brush or lint-free cloth to avoid scratching the finish. The plating is sealed with a lacquer to minimize discoloration or tarnishing. Do not use water when cleaning. This could damage the motor, or the wood, or possibly cause an electrical shock.

3. You can apply a light coat of furniture polish to the wood blades for additional protection and enhanced beauty. Cover small scratches with a light application of shoe polish.

4. **There is no need to oil your fan.** The motor has permanently lubricated bearings.

**IMPORTANT**  
MAKE SURE THE POWER IS OFF AT THE  
ELECTRICAL PANEL BOX BEFORE YOU  
ATTEMPT ANY REPAIRS. REFER TO THE  
SECTION "MAKING ELECTRICAL  
CONNECTIONS"

## *13. Care of Your Fan*

## Problem

## Solution

Fan will not start.

1. Check circuit fuses or breakers.
2. Check line wire connections to the fan and switch wire connections in the switch housing.  
**CAUTION:** Make sure main power is off.
3. Check to make sure the dip switches from the transmitter and receiver are set to the same frequency.

Fan sounds noisy.

1. Make sure all motor housing screws are snug.
2. Make sure the screws that attach the fan blade bracket to the motor hub is tight.
3. Make sure wire nut connections are not rubbing against each other or the interior wall of the switch housing.  
**CAUTION:** Make sure main power is off.
4. Allow a 24-hour "breaking-in" period. Most noise associated with a new fan disappear during this time.
5. If using an optional light kit, make sure the screws securing the glassware are tight. Check that light bulb is also secure.
6. Some fan motors are sensitive to signals from solid-state variable speed controls. If you have installed this type of control, choose and install another type of control.
7. Make sure the upper canopy is a short distance from the ceiling. It should not touch the ceiling.

Remote control malfunction

1. Do not connect the fan with wall mounted variable speed control (s).
2. Make sure the dip switches are set correctly.

*Troubleshooting 14.*

Fan Size	Speed	Volts	Amps	Watts	RPM	CFM	N.W.	G.W.	C.F.
60"	Low	120	0.07	3.31	51	1954.66	14.11 lbs	17.26 lbs	2.31'
	High	120	0.43	31.45	165	7047.29			

These are approximate measures. They do not include Amps and Wattage used by the light kit.

This device complies with part 15 of the FCC Rules. Operation is subject to the following two conditions: (1) This device may not cause harmful interference, and (2) this device must accept any interference received, including interference that may cause undesired operation.

**Warning:** Changes or modifications to this unit not expressly approved by the party responsible for compliance could void the user's authority to operate the equipment.

**NOTE:** This equipment has been tested and found to comply with the limits for a Class B digital device, pursuant to Part 15 of the FCC Rules. These limits are designed to provide reasonable protection against harmful interference in a residential installation. This equipment generates, uses and can radiate radio frequency energy and, if not installed and used in accordance with the instructions, may cause harmful interference to radio communications.

However, there is no guarantee that interference will not occur in a particular installation. If this equipment does cause harmful interference to radio or television reception, which can be determined by turning the equipment off and on, the user is encouraged to try to correct the interference by one or more of the following measures:

- Reorient or relocate the receiving antenna.
- Increase the separation between the equipment and receiver.
- Connect the equipment into an outlet on a circuit different from that to which the receiver is connected.
- Consult the dealer or an experienced radio/TV technician for help.

## *15. Specifications*

©2020 Progress Lighting, Inc.  
701 Millennium Blvd.,  
Greenville, SC 29607  
All Rights Reserved