

**SO DARLING DOLLHOUSE  
MAISON DE POUPÉE SI CHÉRIE  
CASA DE MUÑECAS TAN QUERIDA**



CALL US OR GO ONLINE  
APPELEZ-NOUS OU ALLEZ EN LIGNE  
LLÁMENOS O VISITE NUESTRO SITIO WEB

**⚠ WARNING:**  
CHOKING HAZARD - Small parts.  
Not for children under 3 years.

**⚠ ATTENTION :**  
RISQUE DE SUFFOCATION -  
Petites pièces - ne convient pas  
aux enfants de moins de 3 ans.

**⚠ ADVERTENCIA:**  
PELIGRO DE ASFIXIA - Incluye  
piezas pequeñas. No apto para  
niños menores de 3 años.

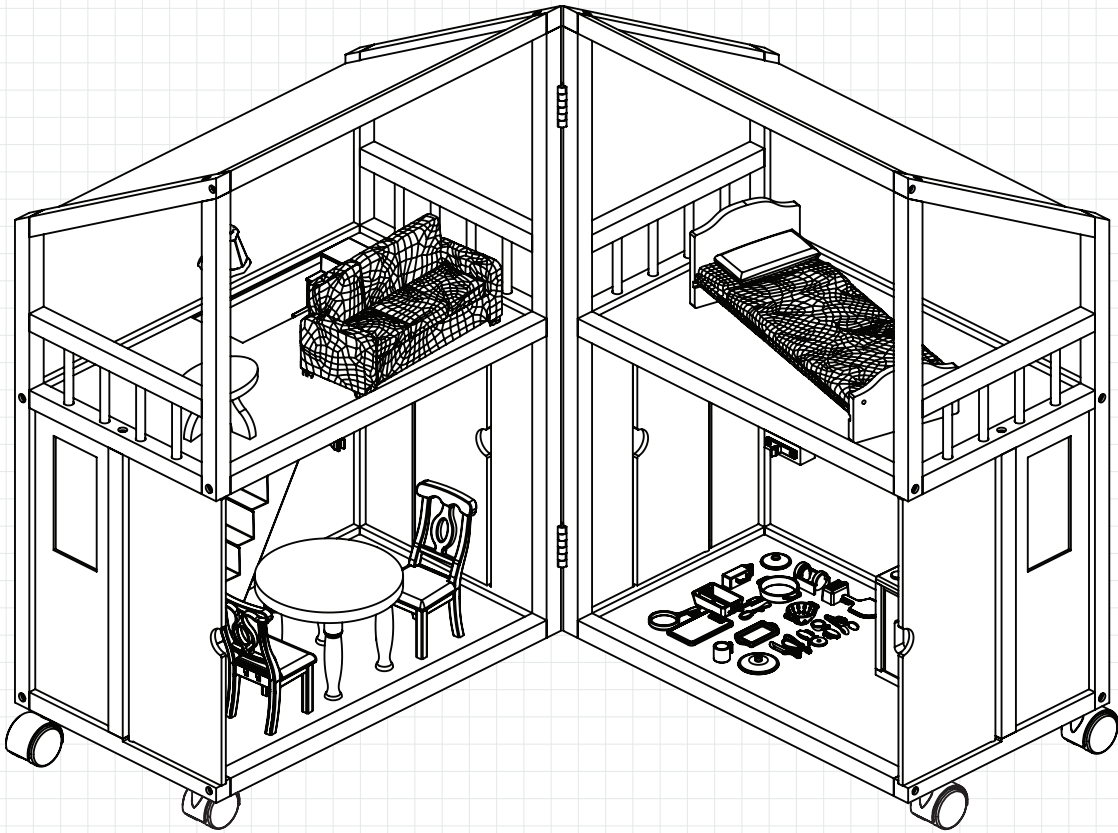

Ages 3+; Assembly time 1 - 1.5 hours  
Âgés 3+; Temps de montage 1 à 1.5 heures  
Edades 3+; Tiempo de montaje de 1 a 1.5 horas

REV 07/16/2024

**ASSEMBLY INSTRUCTIONS / INSTRUCTIONS D'ASSEMBLAGE / INSTRUCCIONES DE MONTAJE**

**FOR 24/7 ONLINE PARTS REPLACEMENT / POUR LE  
REPLACEMENT 24/7 DES PIÈCES EN LIGNE / PARA SOLICITUDES  
ONLINE DE PIEZAS DE REPUESTO DE MANERA ININTERRUMPIDA**

**parts.kidkraft.com**

KidKraft, Inc.  
4630 Olin Road  
Dallas, Texas 75244  
USA

customerservice@kidkraft.com

1.800.933.0771  
972.385.0100

**parts.kidkraft.eu**

KidKraft Netherlands BV  
Barbara Strozziiaan 101-201, 1083 HN  
Amsterdam, The Netherlands

europecustomerservice@kidkraft.com

**BATCH CODE / CODE DE LOT / CÓDIGO DE LOTE**

We do our very best to ensure accuracy in every order, but occasionally we miss something. That's why our warranty covers every single part of your new product for 90 days after purchase.

Nous faisons de notre mieux pour assurer l'exactitude dans chaque commande, mais parfois nous manquons quelque chose. C'est pourquoi notre garantie couvre chaque partie de votre nouveau produit pendant 90 jours après l'achat.

Hacemos nuestro mejor esfuerzo para asegurar la precisión en cada orden, pero a veces se nos olvida algo. Por este motivo, nuestra garantía cubre cada parte de su nuevo producto por los próximos 90 días después de su compra.

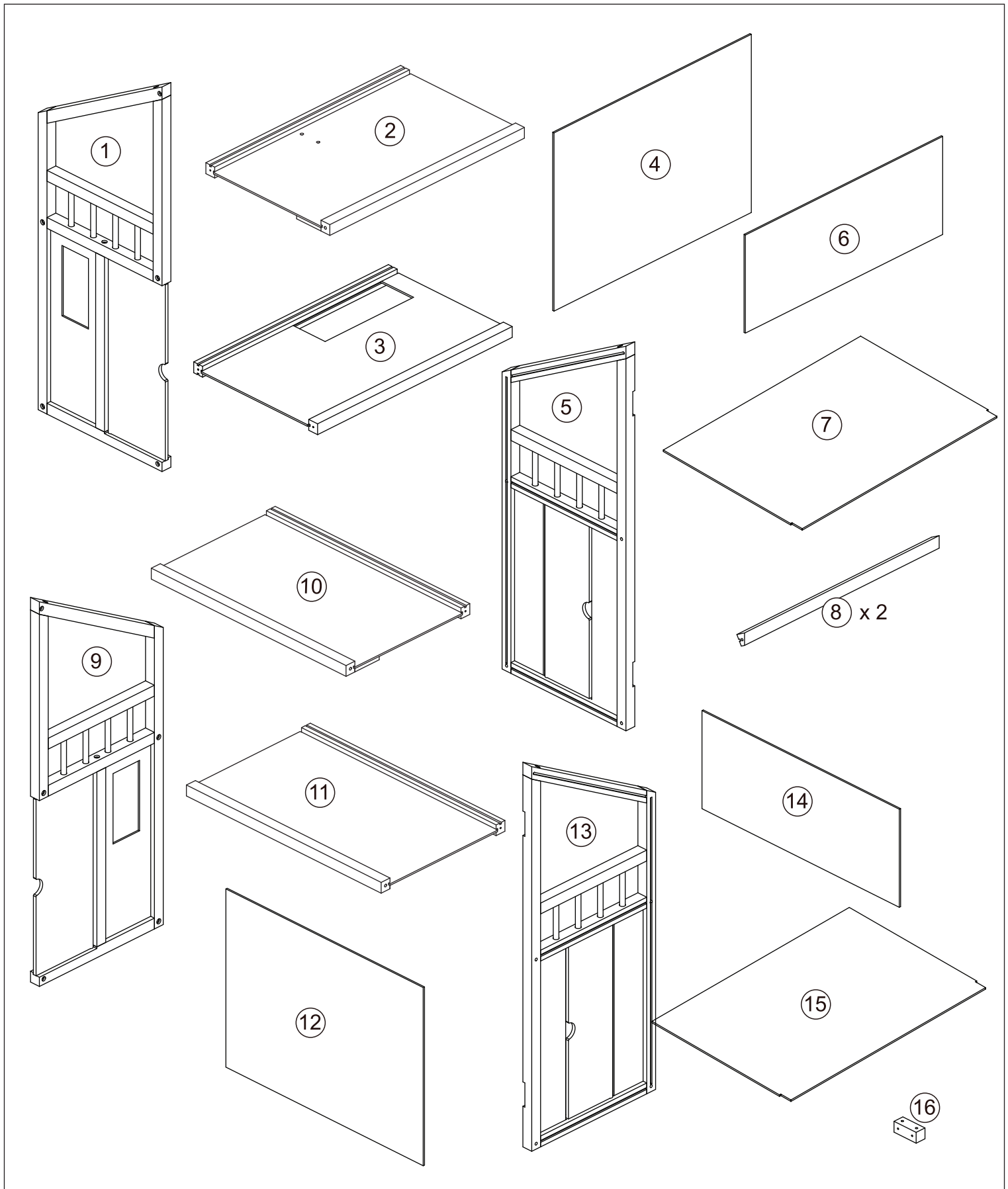





**Parts and Hardware**  
**Pièces et matériel**  
**Partes y Piezas Para Instalación**  
**Teile und Befestigungsmaterial**  
**Parti e componenti meccanici**

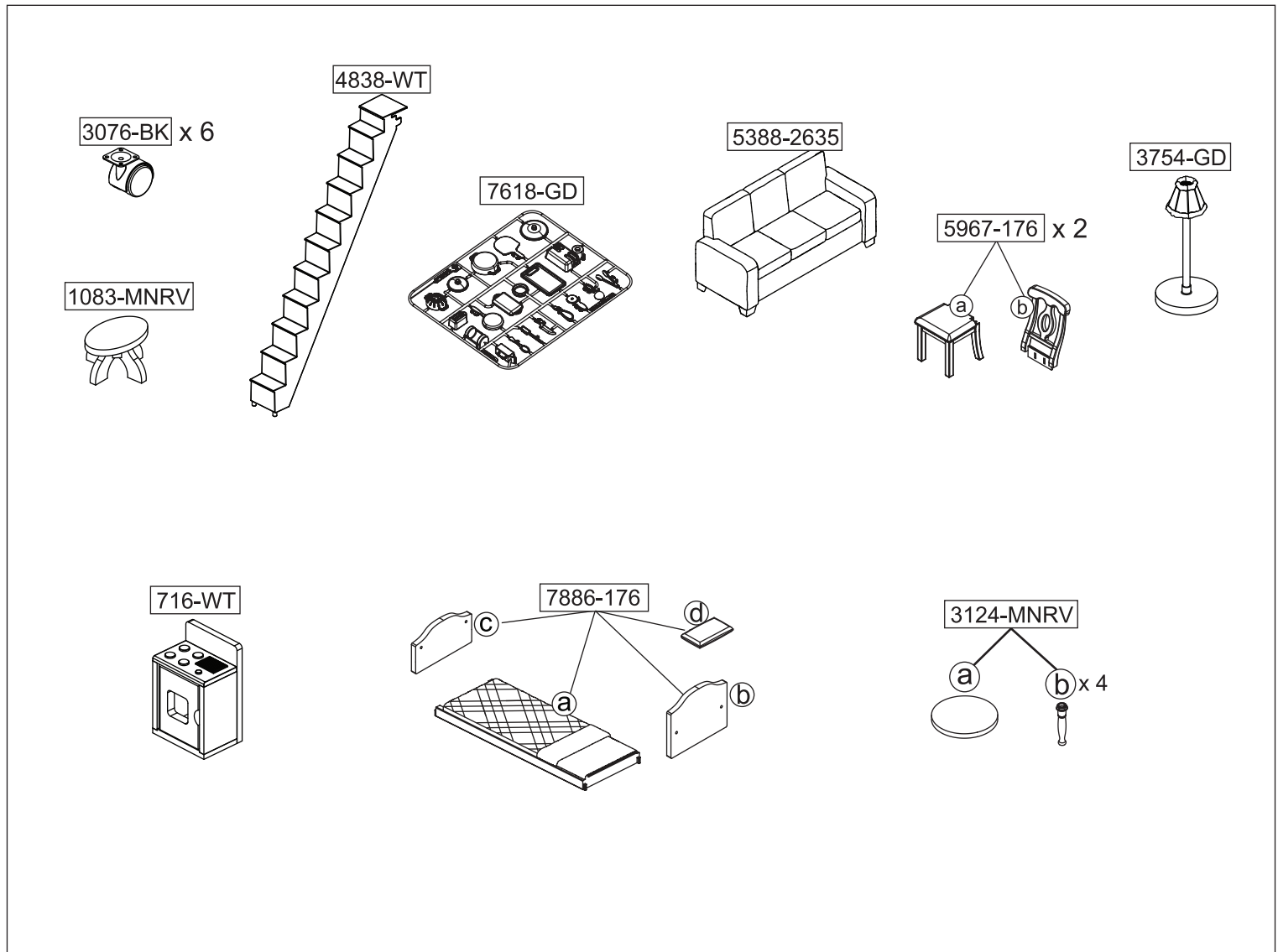

[parts.kidkraft.com](http://parts.kidkraft.com)

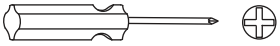
[customerservice@kidkraft.com](mailto:customerservice@kidkraft.com)  
 1.800.933.0771  
 972.385.0100

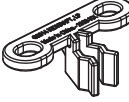

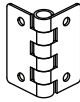
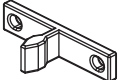
<b>A</b>	<b>x 20</b>	<b>C</b>	<b>x 32</b>	<b>E</b>	<b>x 1</b>	<b>Tool required:</b> <b>Outils requis :</b> <b>Herramientas necesarias:</b> <b>Benötigtes Werkzeug:</b> <b>Attrezzi necessari:</b>   <b>Phillips® screwdriver</b> <b>Tournevis Phillips®</b> <b>Destornillador Phillips®</b> <b>Kreuzschraubenzieher</b> <b>Cacciavite Phillips®</b>
						
<b>B</b>	<b>x 6</b>	<b>D</b>	<b>x 2</b>	<b>F</b>	<b>x 1</b>	
						
<b>38 mm</b>		<b>12 mm</b>				
<b>22 mm</b>						

Parts and Hardware  
 Pièces et matériel  
 Partes y Piezas Para Instalación  
 Teile und Befestigungsmaterial  
 Parti e componenti meccanici

All hardware dimensions are approximate.  
 Toutes les dimensions du matériel  
 sont approximatives.  
 Todas las dimensiones de las herramientas  
 son aproximaciones.



1

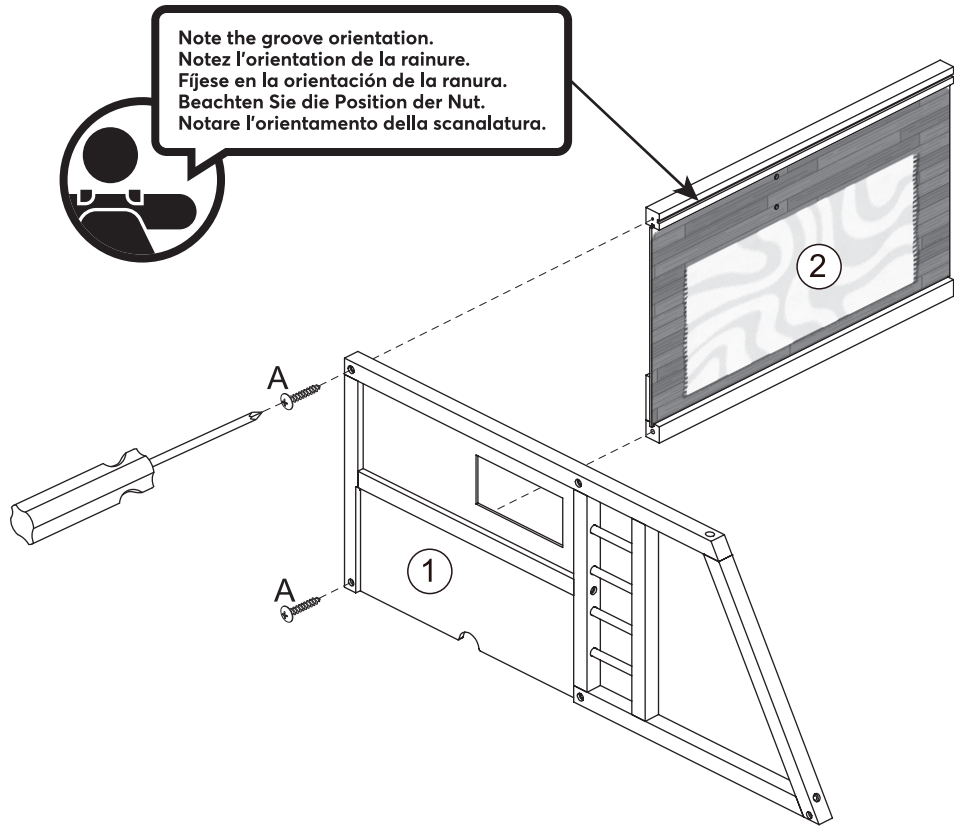

2

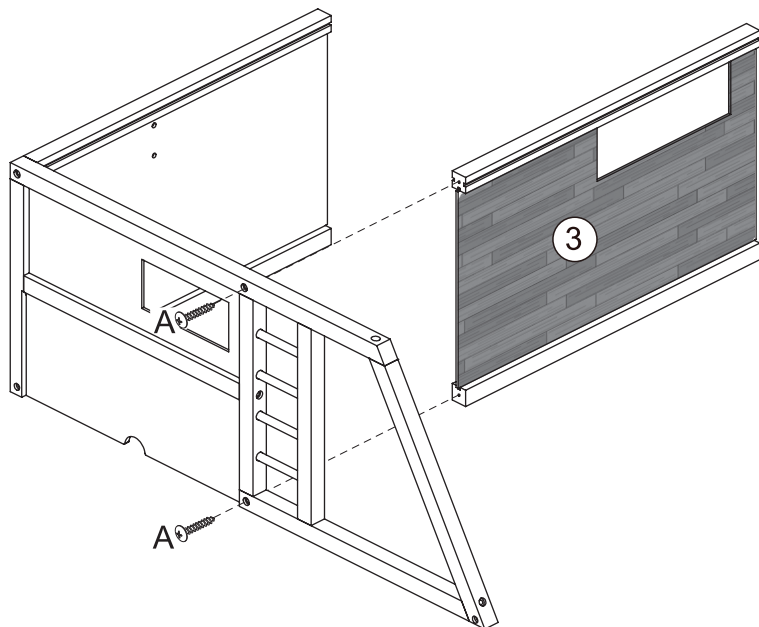

3

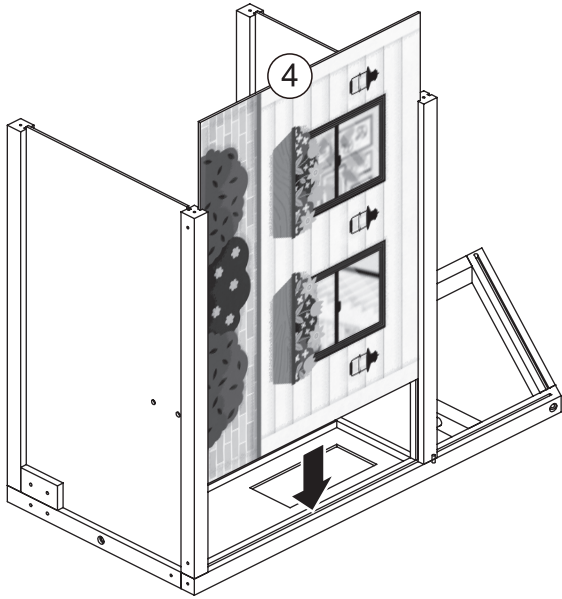

4

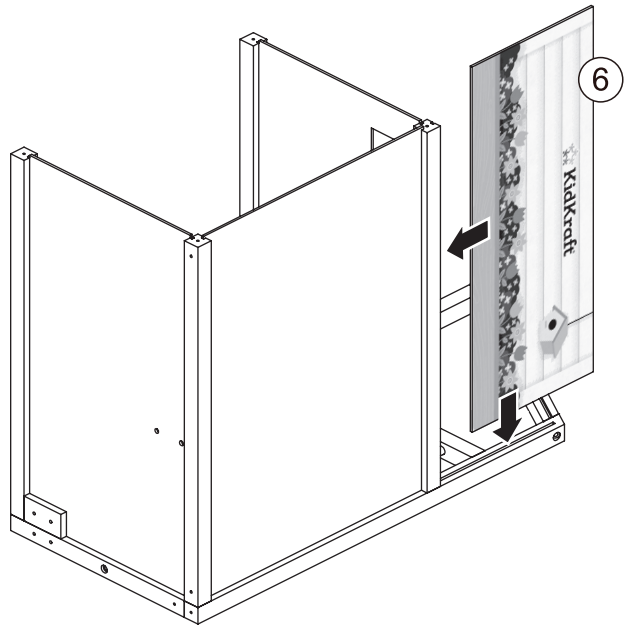

5

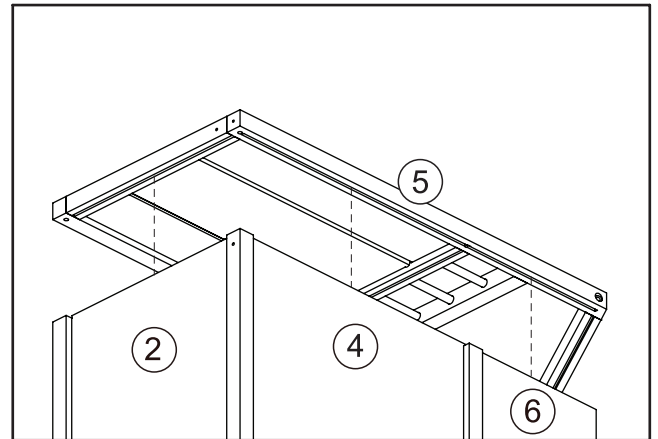
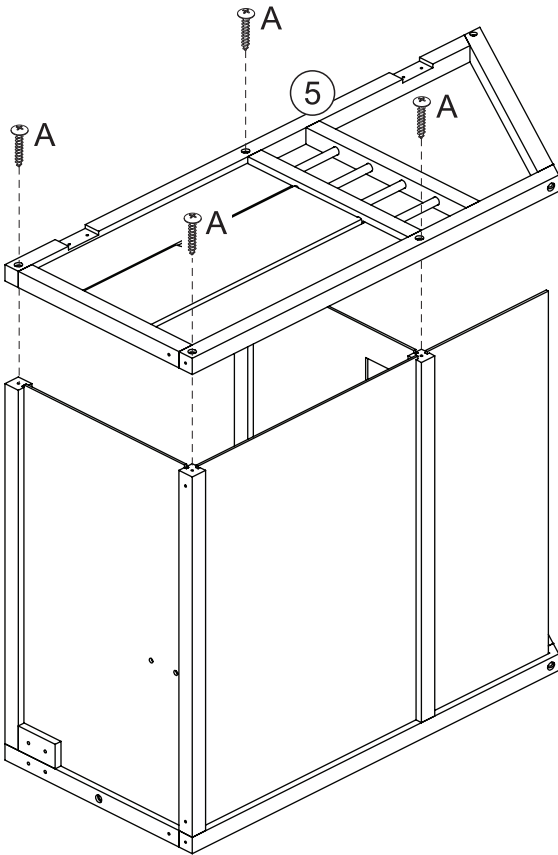

Underneath View  
 Vue de dessous  
 Vista inferior  
 Unteransicht  
 Vista dal basso

6

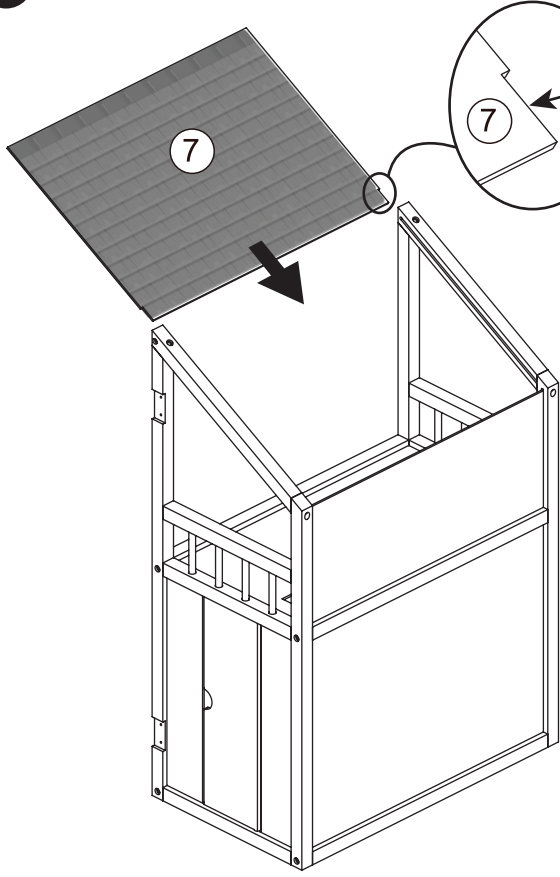

Note orientation of notch  
 Notez l'orientation de l'entaille  
 Tenga en cuenta la orientación de la muesca  
 Ausrichtung der Kerbe beachten  
 Prestare attenzione all'orientamento della scanalatura

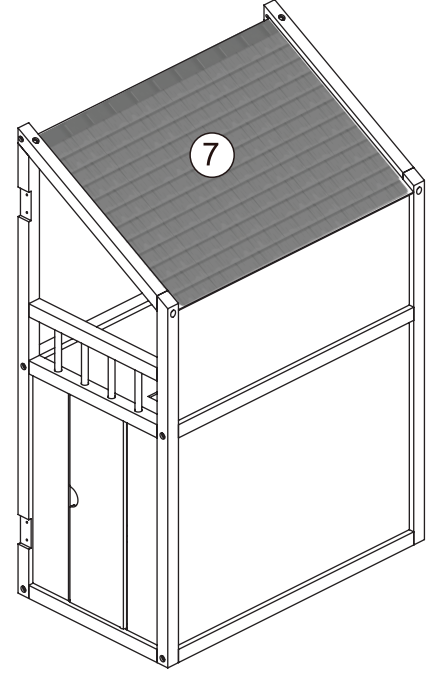
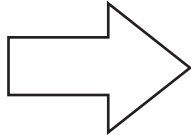

7

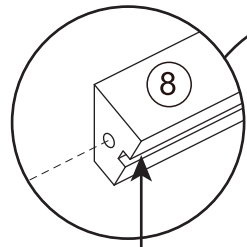

Note the groove orientation.  
 Notez l'orientation de la rainure.  
 Fijese en la orientación de la ranura.  
 Beachten Sie die Position der Nut.  
 Notare l'orientamento della scanalatura.

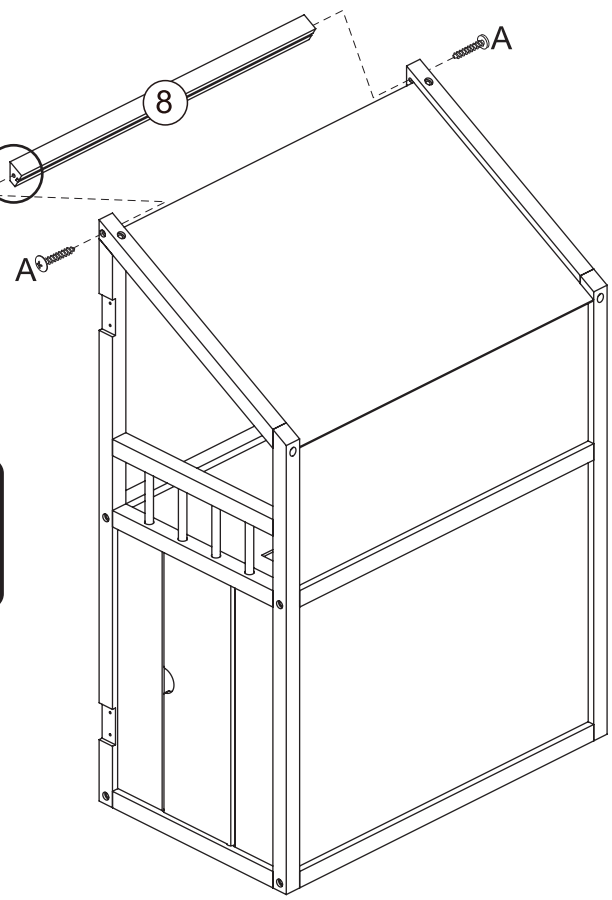

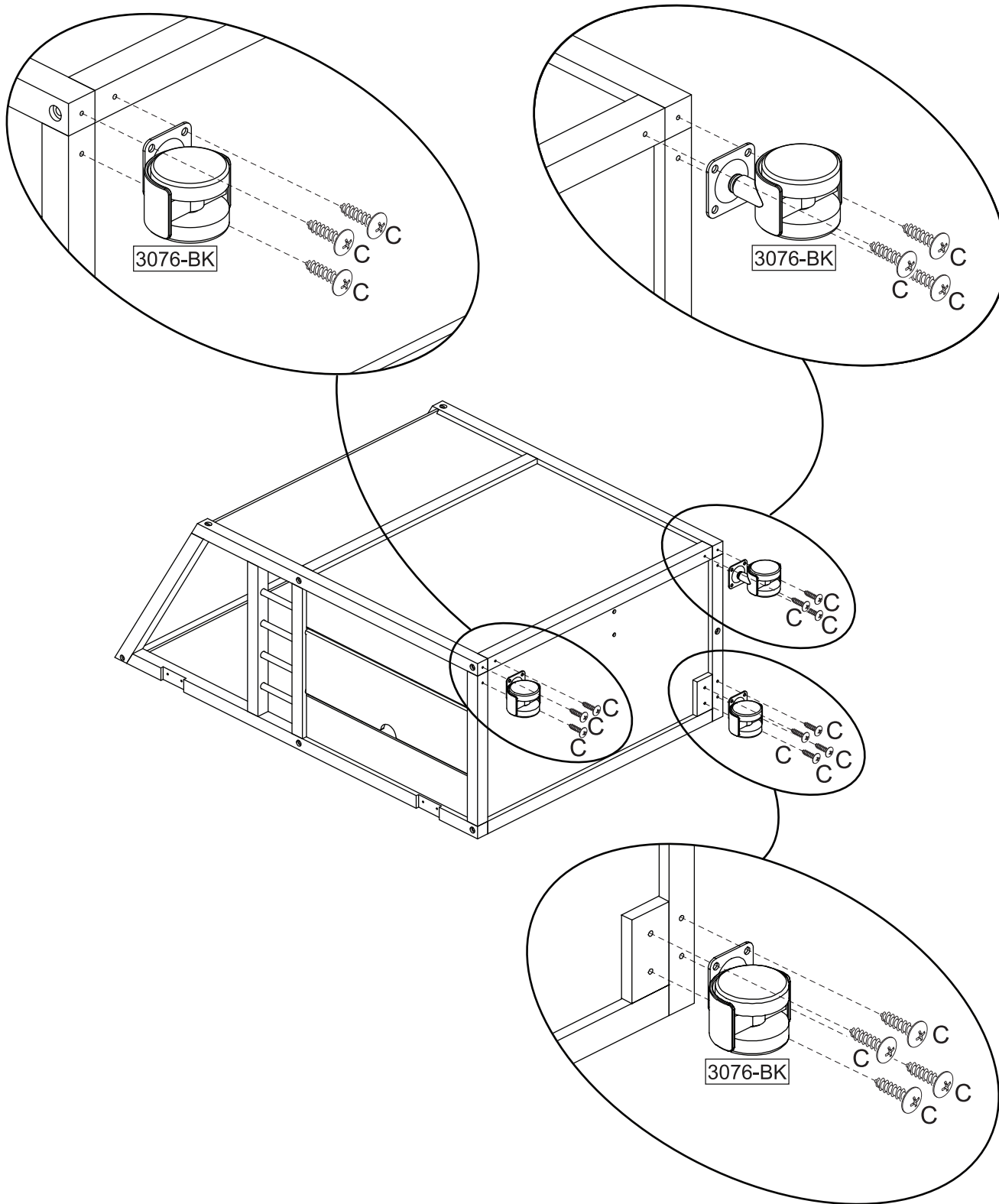

9

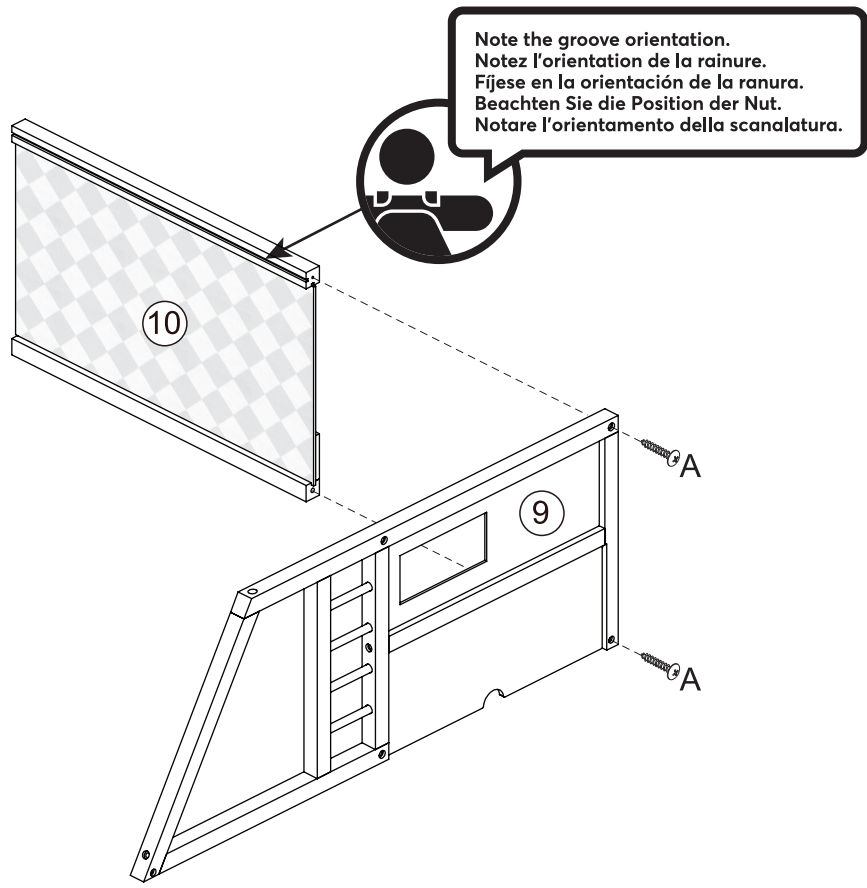

10

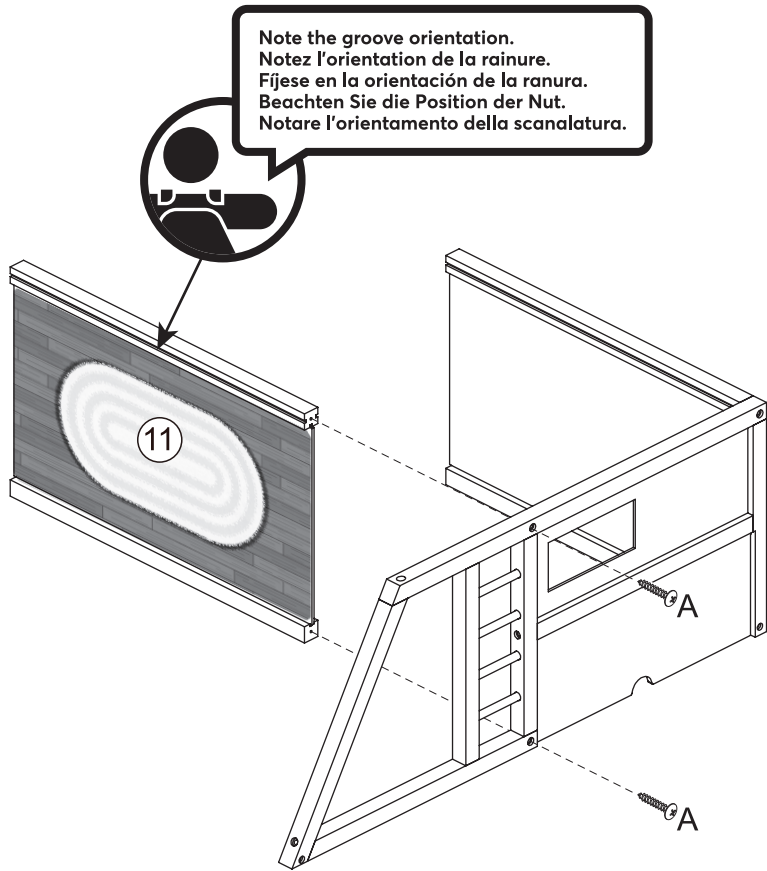



11

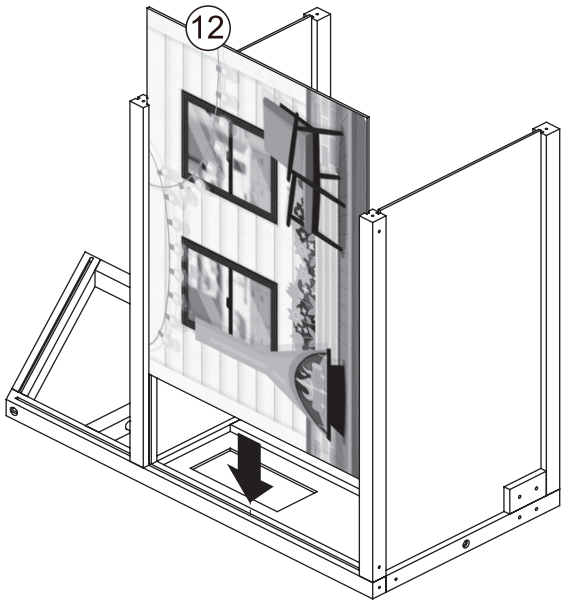

12

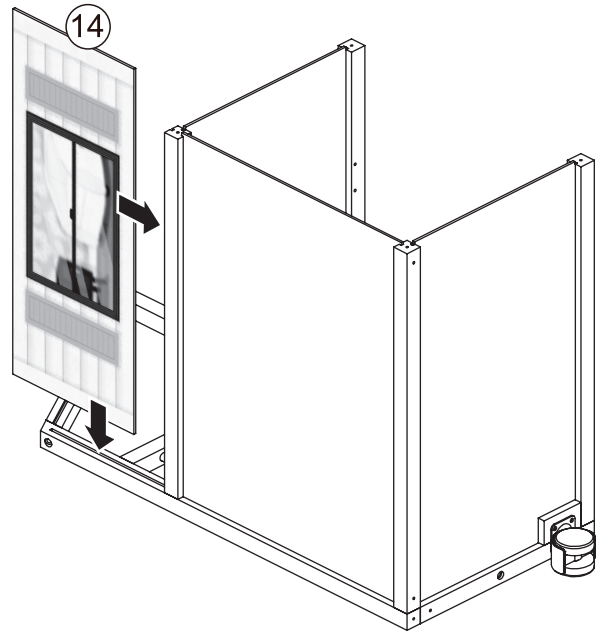

13

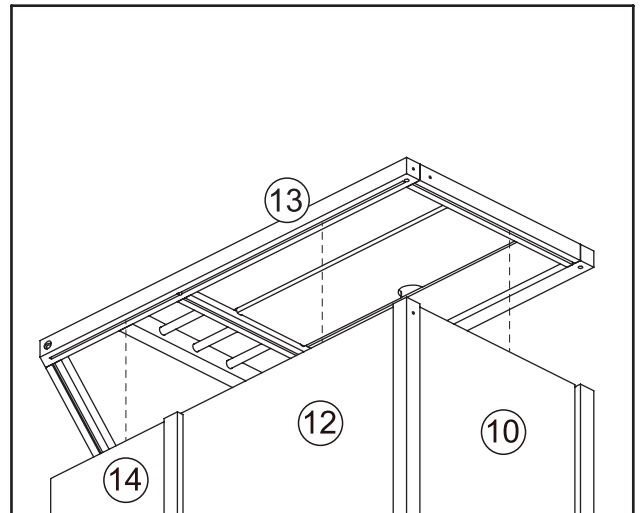
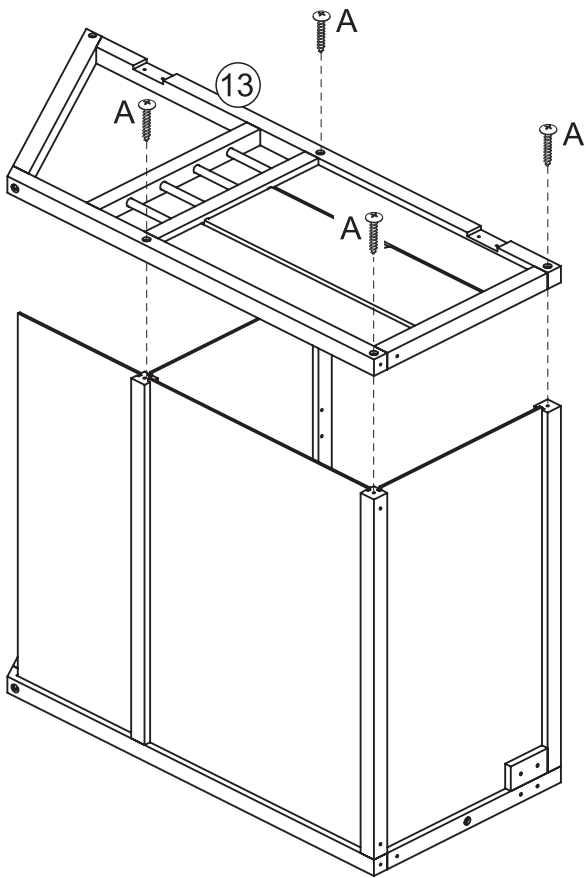

Underneath View  
 Vue de dessous  
 Vista inferior  
 Unteransicht  
 Vista dal basso



14

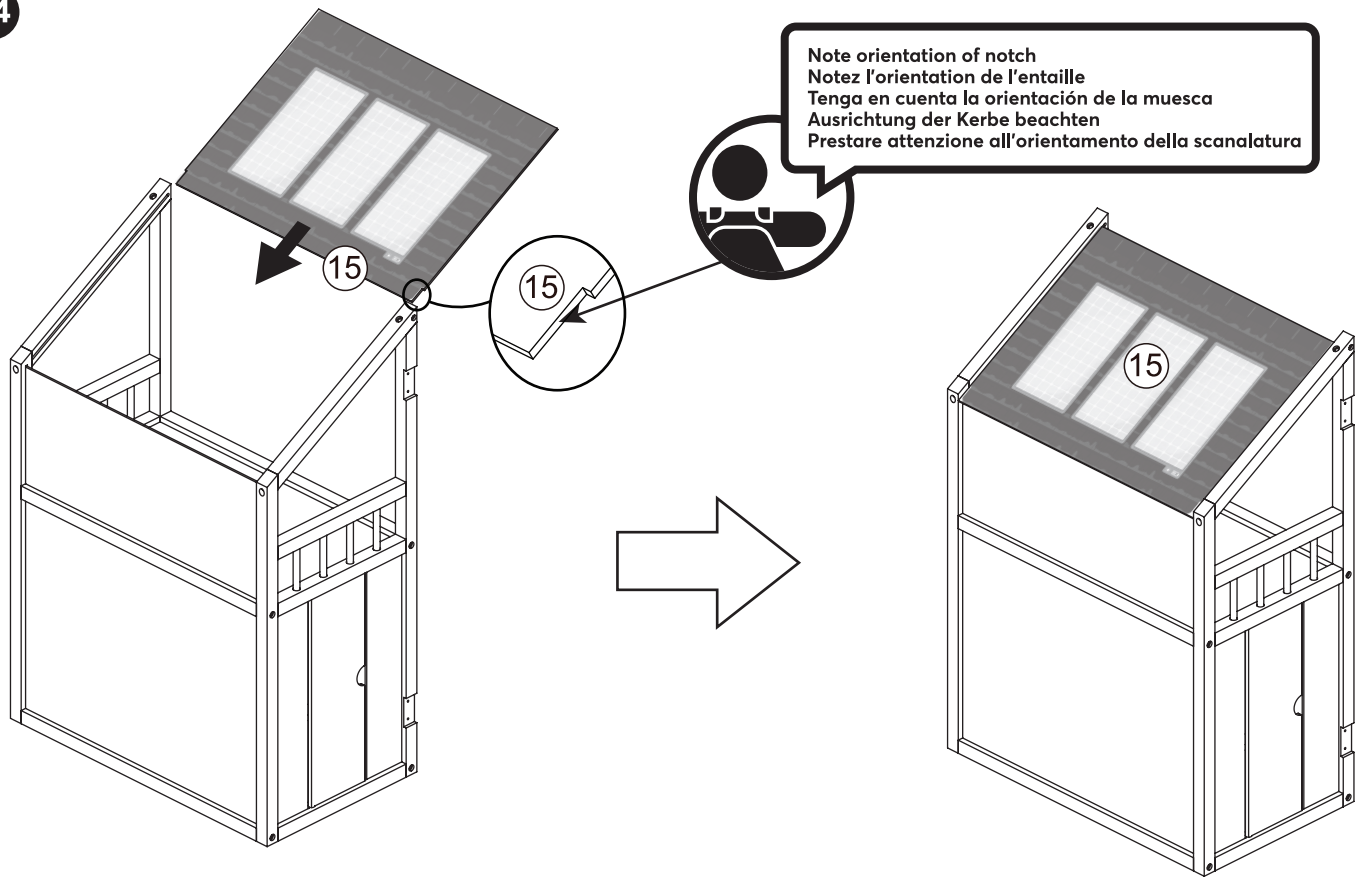

15

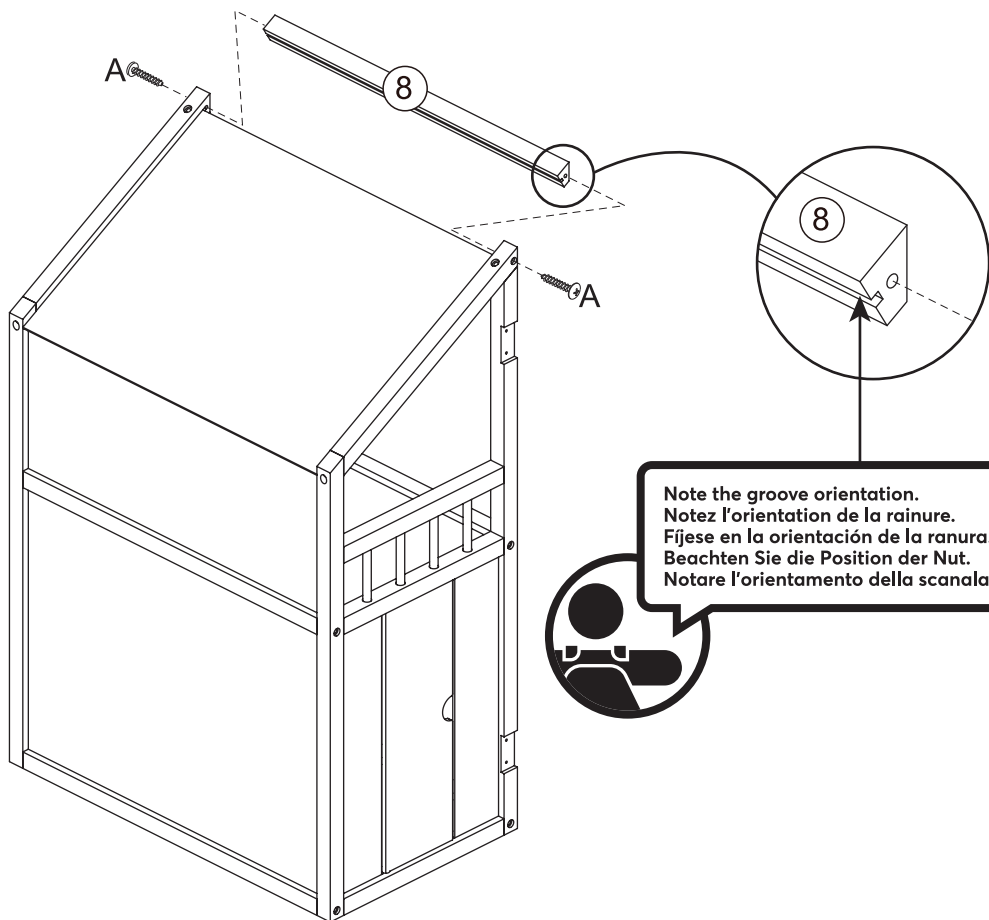

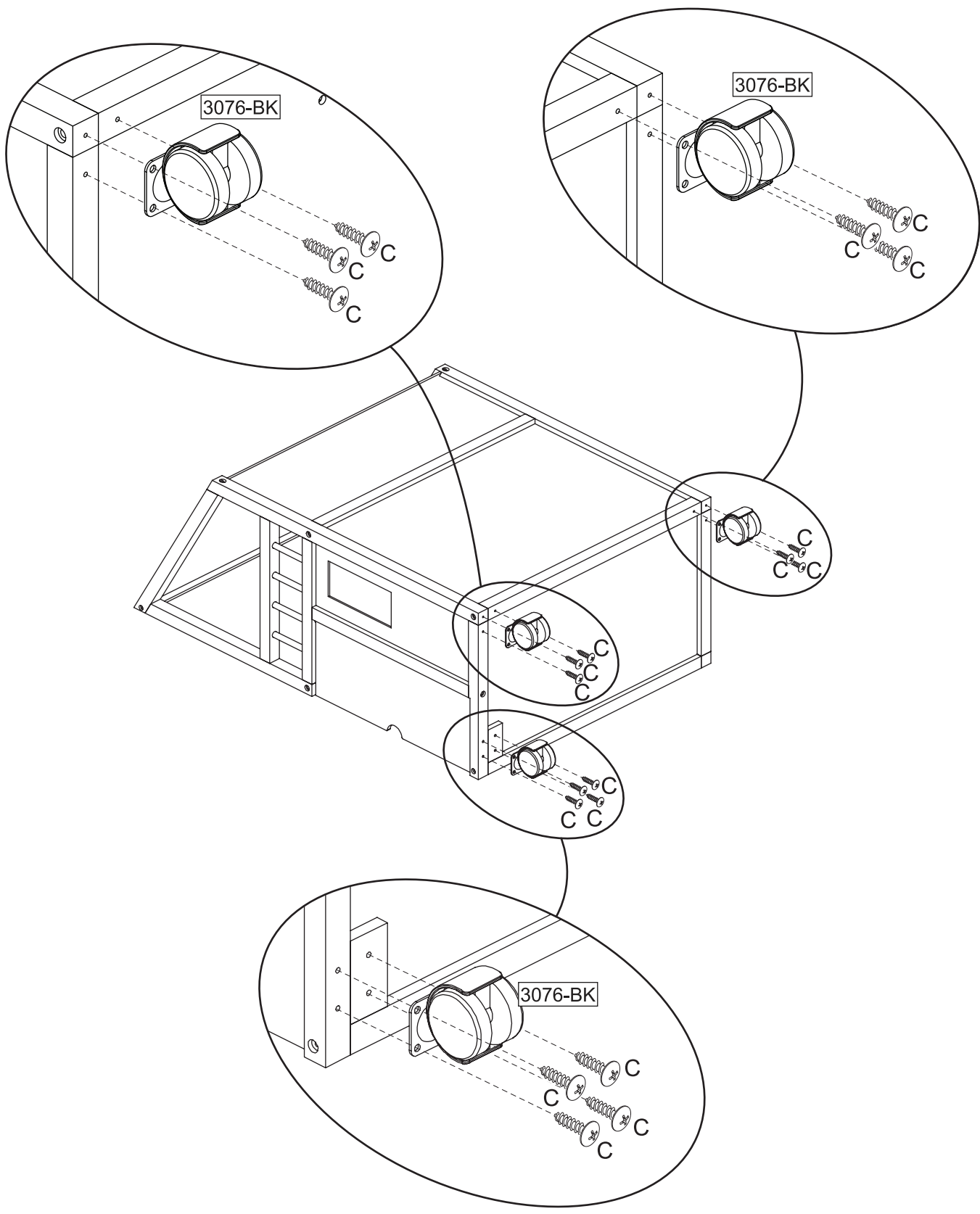

17

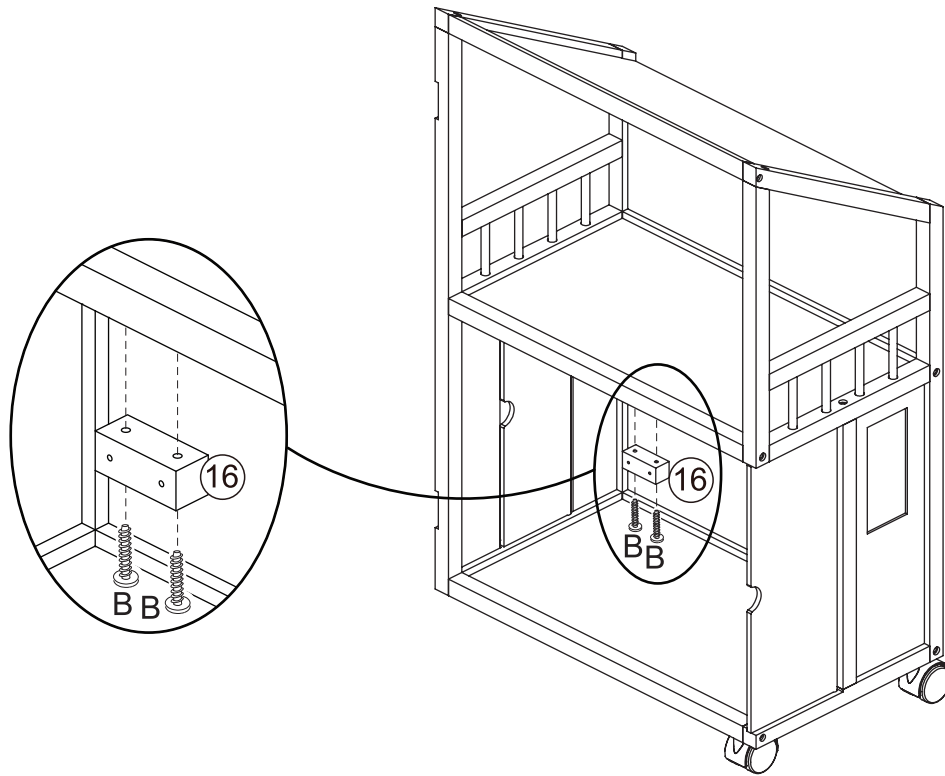

18

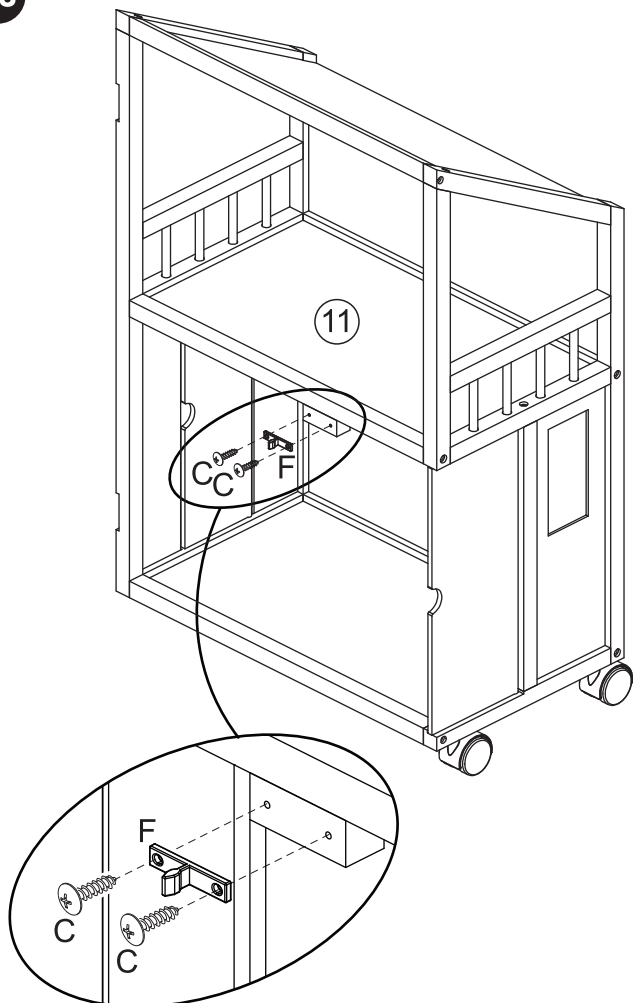

19

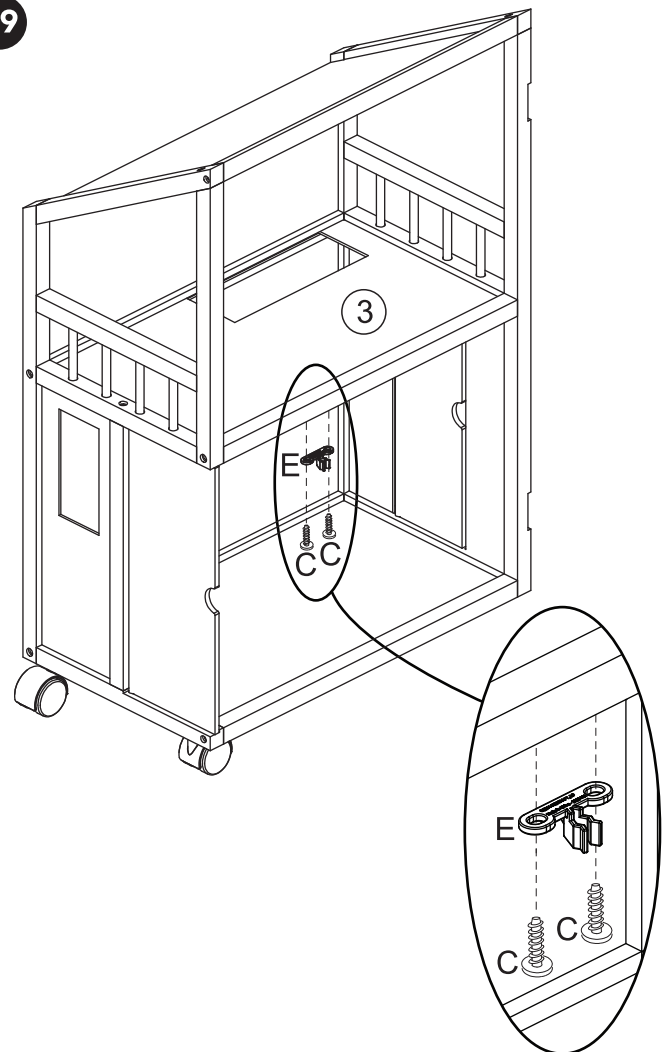

20

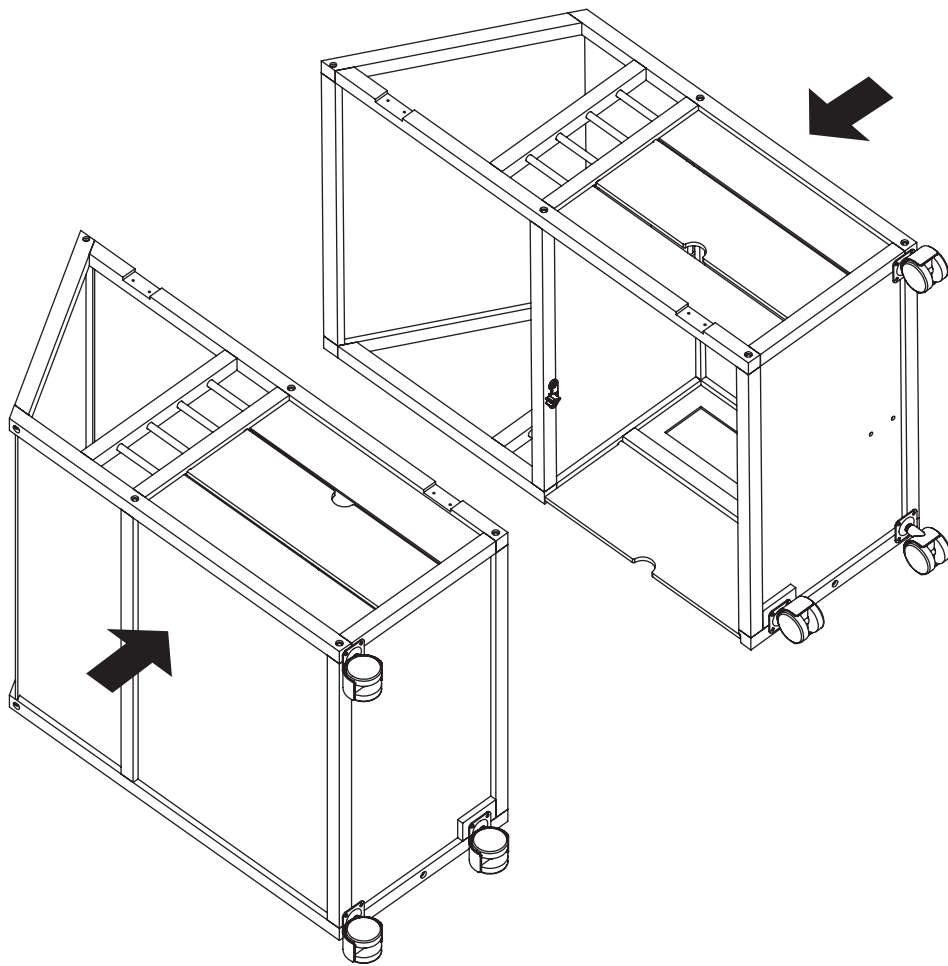

21

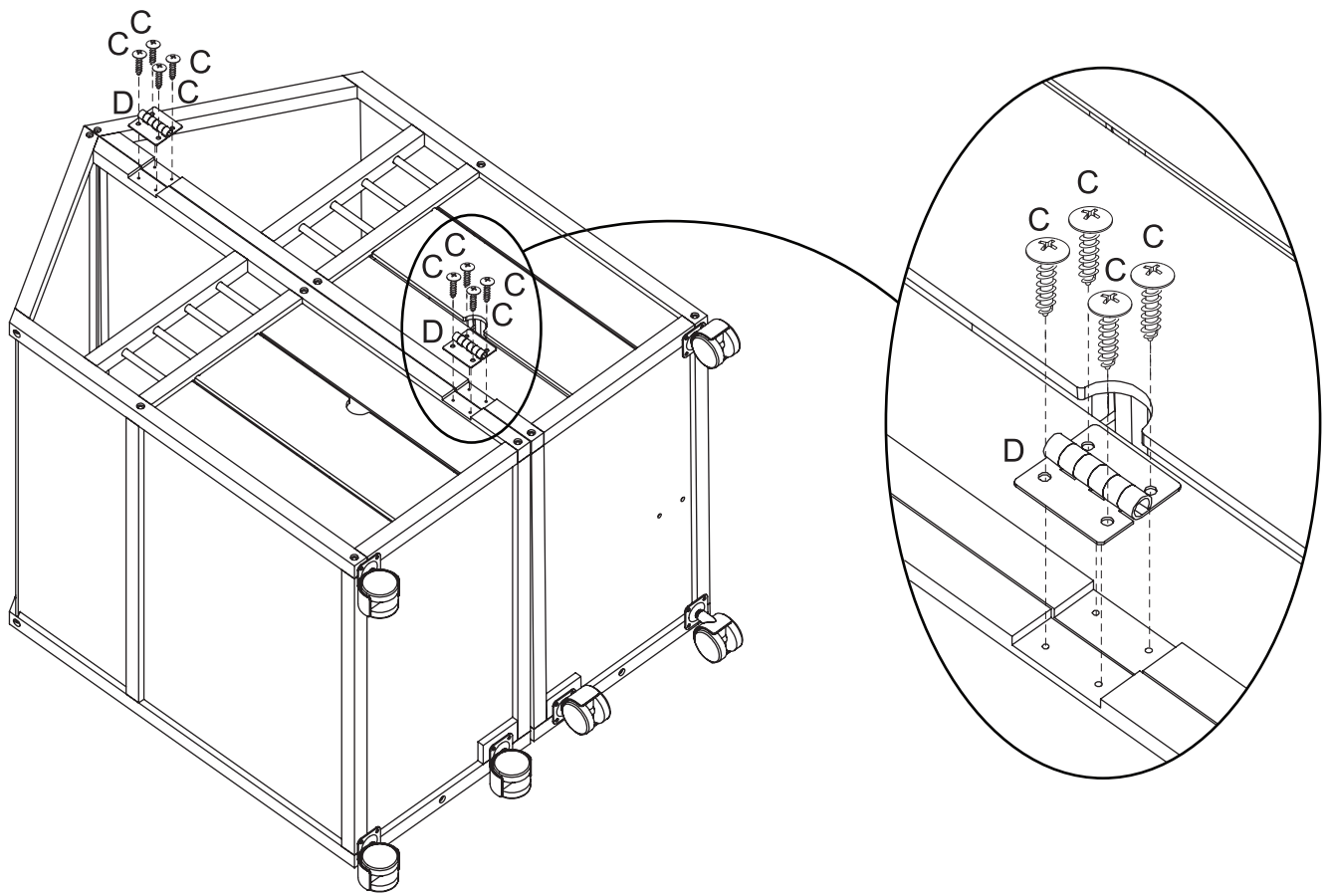

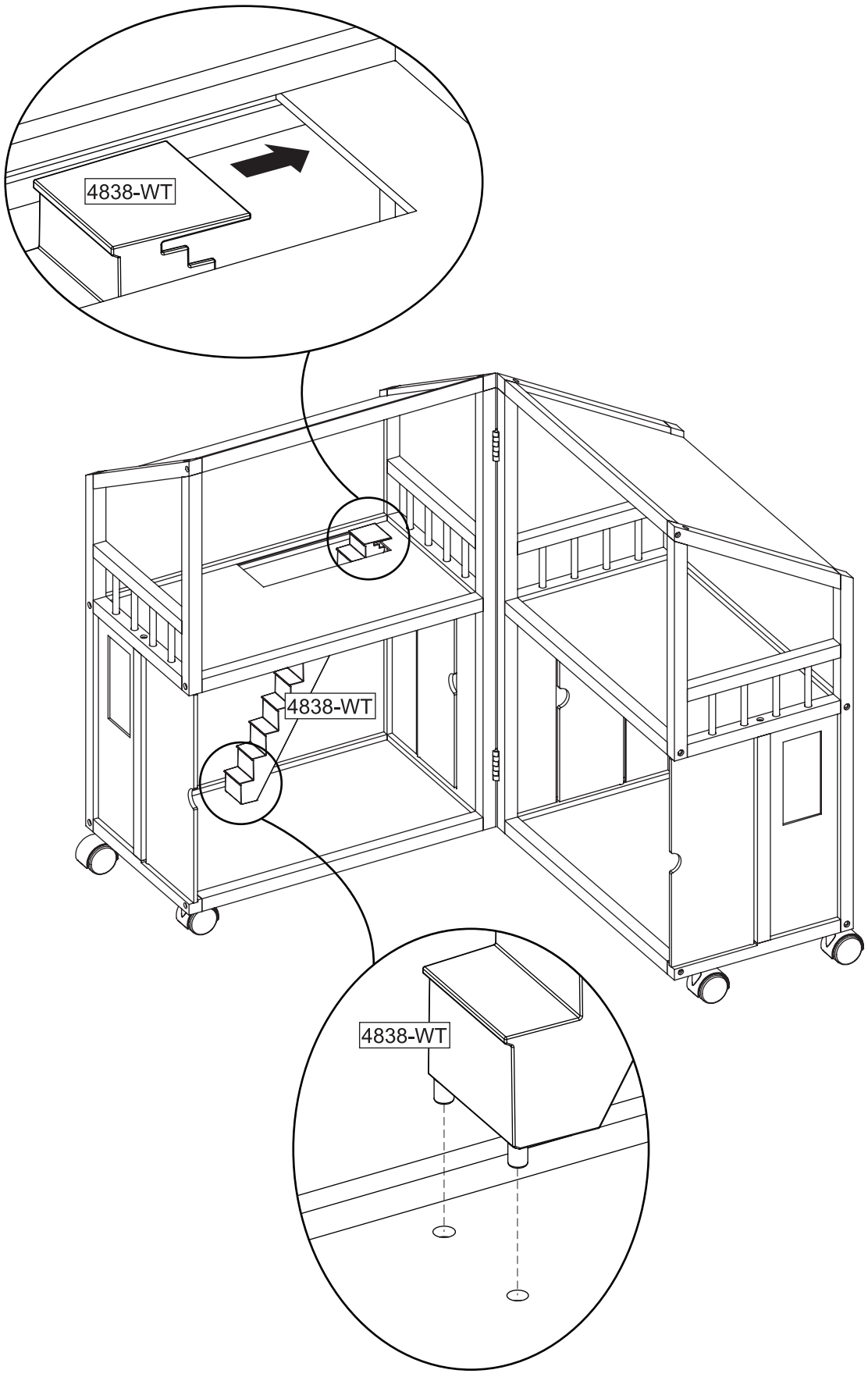

23

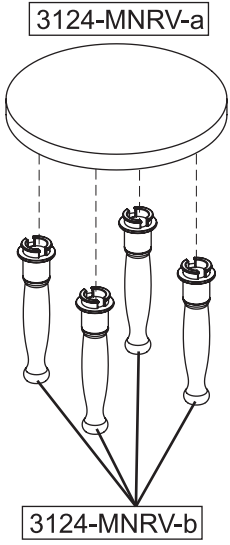

24

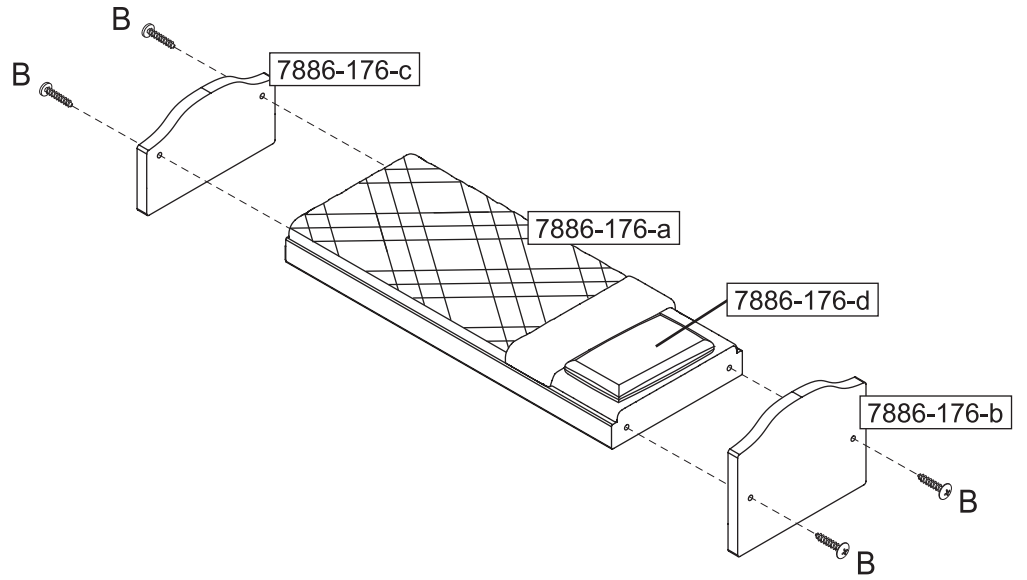

25 x 2

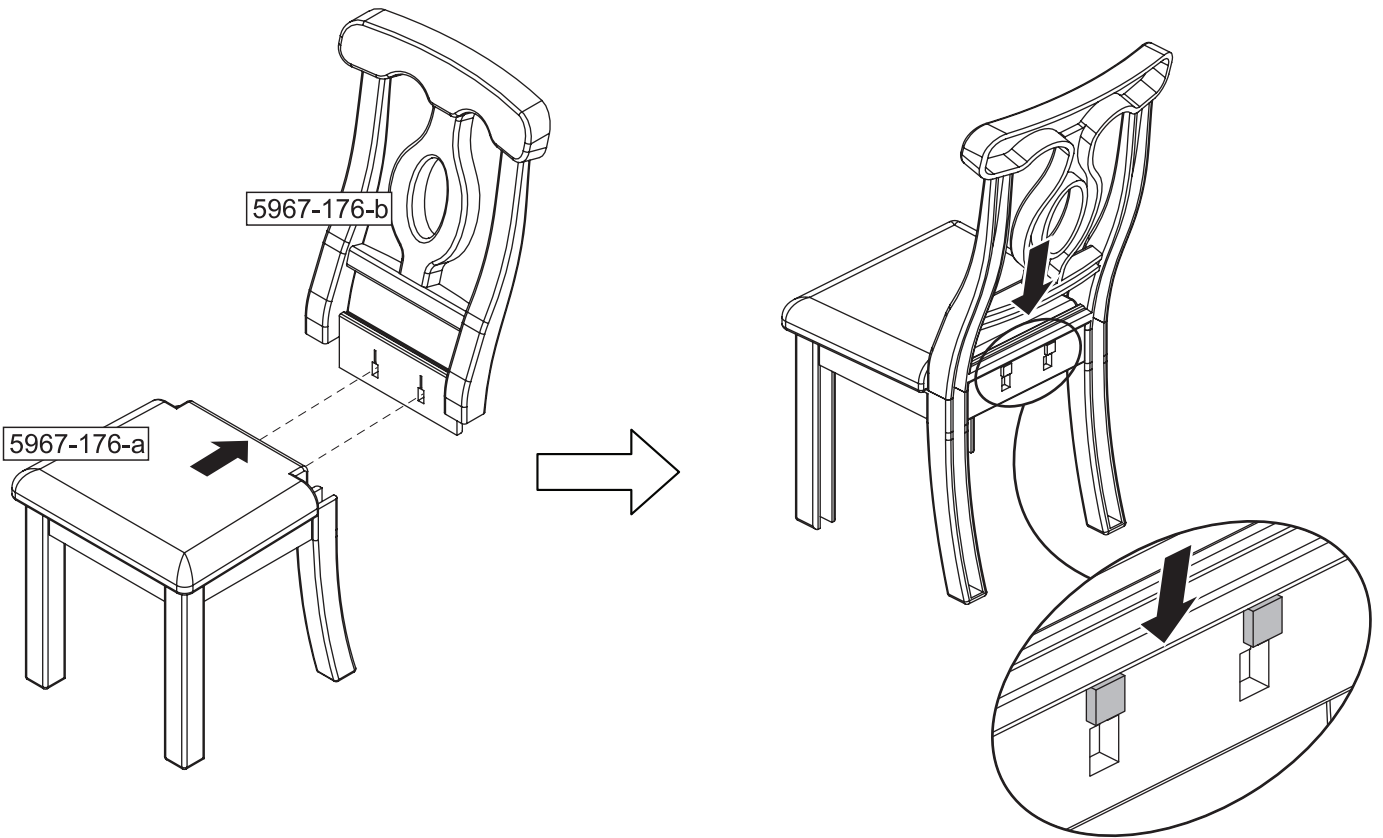

26

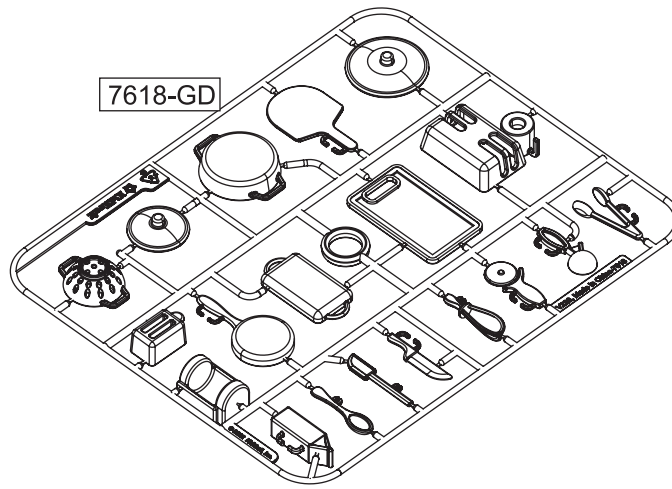

**ADULTS:** Fully remove parts from frame and discard the frame. File down any sharp points before giving parts to child.

**ADULTES :** Retirez entièrement les pièces du cadre et jetez le cadre. Limez toutes les parties pointues avant de donner les pièces à l'enfant.

**ADULTOS:** Retire completamente las piezas del marco y deseche el marco. Lime las puntas afiladas antes de dar las piezas al niño.

**ERWACHSENE:** Entfernen Sie die Teile vollständig vom Rahmen und entsorgen Sie den Rahmen.

Feilen Sie alle scharfen Stellen ab, bevor Sie die Teile an Ihr Kind weitergeben.

**ADULTI:** Rimuovere completamente le parti dal telaio e gettare il telaio. Limare eventuali punti taglienti prima di consegnare i pezzi al bambino.



27

Test the electronics before proceeding with assembly. If you have any issues, please contact customer service.  
 Tester les pièces électroniques avant de procéder à l'assemblage. Pour tout problème, veuillez contacter le service client.  
 Prueba los dispositivos electrónicos antes de empezar el montaje. Si tienes algún problema, ponte en contacto con Atención al cliente.  
 Testen Sie die Elektronik, bevor Sie mit der Montage fortfahren. Kontaktieren Sie bei Problemen bitte den Kundenservice.  
 Testare le parti elettroniche prima di procedere con il montaggio. In caso di problemi, contattare il servizio clienti.

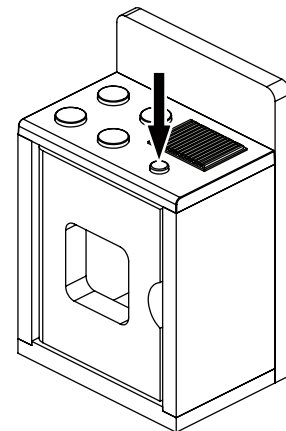
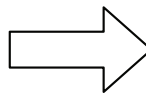
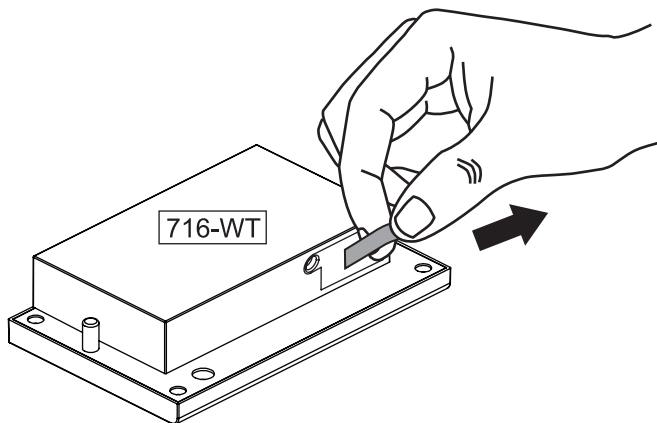



**Battery Replacement Guide**  
**Guide de remplacement de batterie**  
**Guía para cambiar las baterías**  
**Anleitung zum Ersetzen der Batterien**  
**Guida per sostituire la batteria**

**A1**

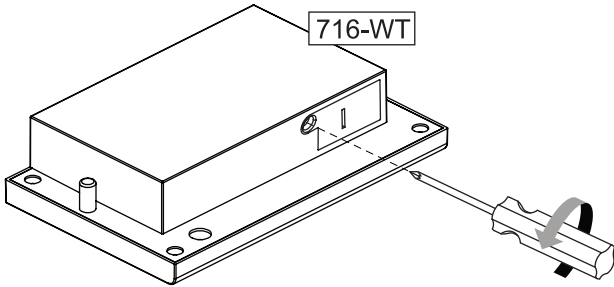

**A2**

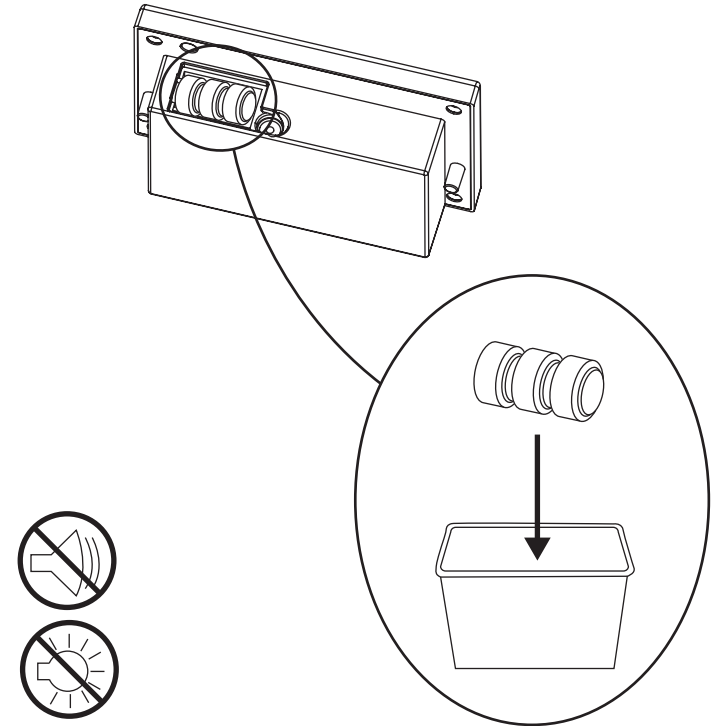

**A3**

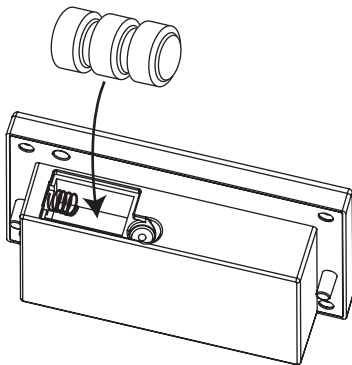
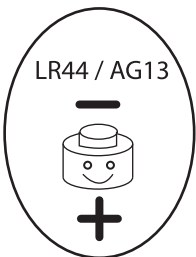

**A4**

