

ADJUSTMENT SETTING #3
CLOSE IN 1 SECOND

12 ADJUSTMENT POSITIONS
FROM FULL TO OFF

DETAIL Y
SCALE 2.000

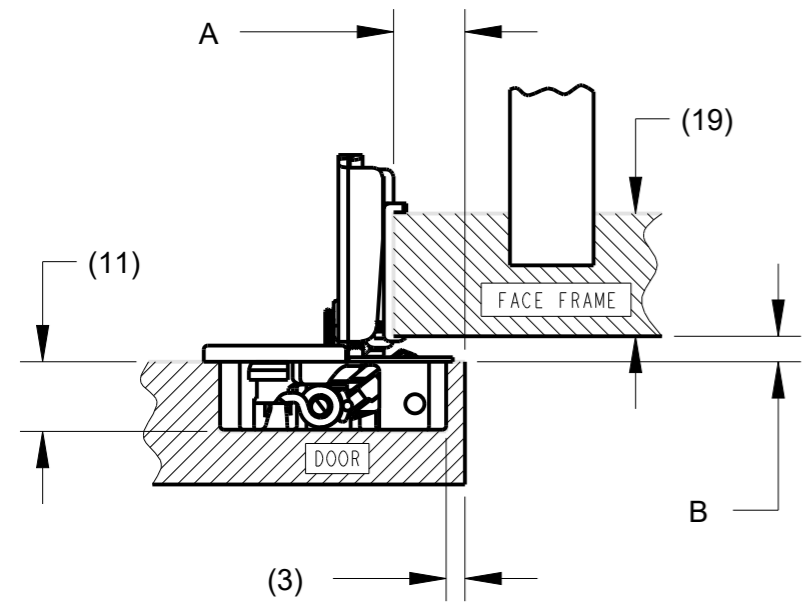

FINISHED GOODS TABLE			
HR ITEM NUMBER	PRODUCT DESCRIPTION	A	B
9390ADJ	9390 HINGE, 1/2" OVERLAY, COMPACT ADJUSTABLE SOFT-CLOSE, WITHOUT DOWELS	12.7	5.1
9390-2-000ADJ	9390 HINGE, 1/2" OVERLAY, COMPACT ADJUSTABLE SOFT-CLOSE, WITH DOWELS	12.7	5.1
9394-000ADJ	9394 HINGE, 1-1/4" OVERLAY, COMPACT ADJUSTABLE SOFT-CLOSE, WITH DOWELS	31.8	5.1



HARDWARE RESOURCES RESERVES THE RIGHT TO CHANGE SPECIFICATIONS WITHOUT NOTICE. IN CASE OF A DISCREPANCY, ACTUAL PART GEOMETRY SUPERSEDES THIS DOCUMENT.

THE INFORMATION CONTAINED WITHIN THIS DRAWING IS THE SOLE PROPERTY OF HARDWARE RESOURCES INC. ANY REPRODUCTION IN PART OR WHOLE WITHOUT WRITTEN PERMISSION OF HARDWARE RESOURCES INC. IS PROHIBITED.

DOCUMENT STATUS Released	
UNLESS OTHERWISE SPECIFIED DIMENSIONS ARE IN MILLIMETERS (MM)	
MATERIAL STEEL	FINISH ZINC PLATE
THIRD ANGLE PROJECTION	DATE 19MAY2022

DESCRIPTION		
9390 HINGE, COMPACT ADJUSTABLE SOFT-CLOSE		
DRAWING NUMBER 9390_ADJUSTABLE		REV B
SIZE A3	SCALE 1.000	SHEET 1 / 1