

DEPRESSED THREAD
AT SEAMS

SIGHT "H" @ "E"

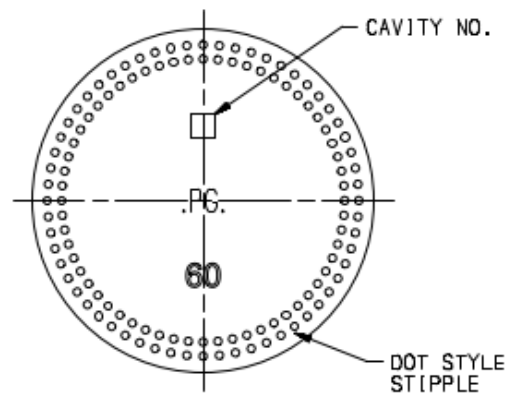
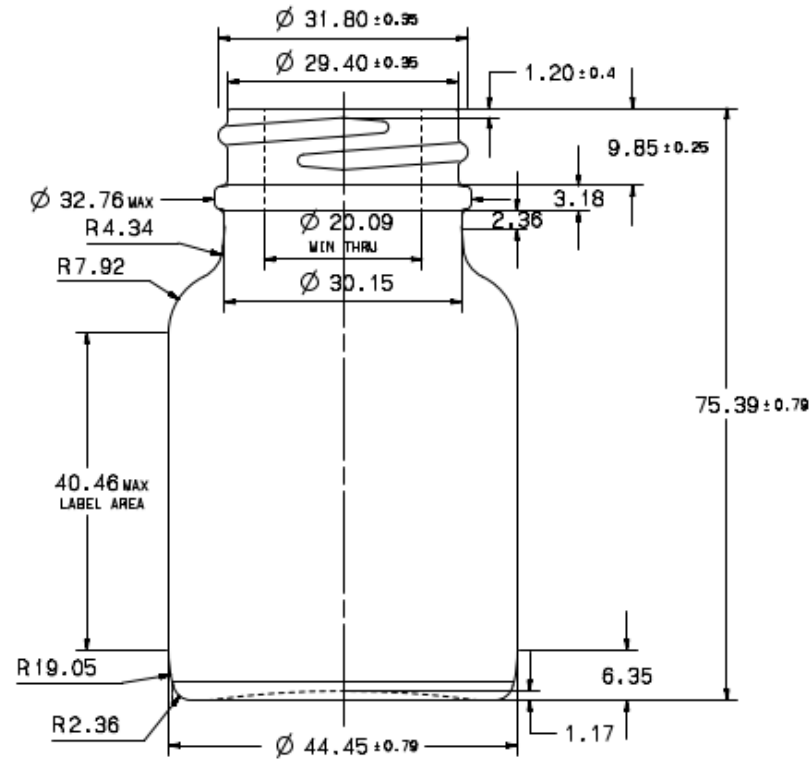

		TYPE & COLOUR	THROUGH BORE (min)		
		III & AMBER	20.09		
OFC. (ml)	FILLING CAP.(ml)	WEIGHT (g)	NECK FINISH		
67-73	----	70.79 ± 15	GPI 400-33mm-405 C/R		

DISCLAIMER

This specification does not relieve the customer of their ultimate responsibility for the determination of the appropriate container. It is the customer's responsibility to select the appropriate packaging based upon all information at their disposal including the specific application, regulatory compliance, product compatibility and shipping requirements. WE HEREBY DISCLAIM AND EXCLUDE ANY EXPRESS OR IMPLIED WARRANTIES, INCLUDING WITHOUT LIMITATION THE IMPLIED WARRANTIES OF MERCHANTABILITY AND FITNESS FOR A PARTICULAR PURPOSE.

DISTRIBUTED BY:



REF NO.:

DWG32036

DESCRIPTION:

60 cc Glass Wide Mouth Packer, 38 mm

Primary / Secondary Packaging Specification

Product : 60 ML W/M PACKER

PGL Ref #	GKXXXXA	GKXXXXB	GKXXXXC	GKXXXXD	GKXXXXE	UOM	BOX SIZE	445 X 330 X 248	mm		
Component Per Set	BOX	PARTITION	TRAY	PLATE	SLEEVE		PARTITION SIZE	NA	mm		
	1	0	3	0	0		TRAY SIZE	425 X 318 X 76	mm		
Number of Plies	3	0	3	0	0	No.	PLATE SIZE	NA	mm		
							SLEEVE SIZE	NA	mm		
Type of Material	KRAFT	NA	KRAFT	NA	NA		PACKING ARRENGMENT	09x08x03 = 216 PCS / BOX			
Type of Flute	C	NA	C	NA	NA		Remarks: GLASS TO GLASS TRAYS IN A CARTON NECKS UP 8 ROWS OF 9 PCS., 72 BOTTLES PER TRAY, 3 TRAYS PER CARTON CARTONS TO BE PALLETIZED RIGHT SIDE UP 1. TIER SHEETS : PLACE ONE CHIPBOARD TIER SHEET ON PALLET AND ONE ON TOP OF LOAD. (TOP TIER SHEET NOT NEEDED IF USING THE BAGGER) 2. SIDE PROTECTOR (CORNER BOARDS) : USE SIDE & TOP EDGE PROTECTORS AT CORNERS INSIDE. BOTTOM OF PROTECTORS TO BE EVEN WITH THE TOP OF THE PALLET. 3. BAGGER : SHRINK WRAP BAG AROUND ENTIRE LOAD INCLUDING PALLET. WHEN BAGGER IS NOT AVAILABLE, USE THE FOLLOWING ALTERNATIVE WRAPPING METHOD 4. ALTERNATIVE WRAPPING STRETCH WRAP : USE AUTOMATIC STRETCH WRAP MACHINE. USE APPROPRIATE GAUGE WRAP FOR TALL PALLET. STRETCH WRAP. (3 WRAPS ON TOP & 3 WRAPS ON BOTTOM OF LOAD). STRETCH WRAP LOAD TO PALLET. STRETCH WRAP ENTIRE PALLET. 5. STRAPS : USE AUTOMATIC STRAPPING TOOL. 2 VERT. STRAPS LONGWAY 5" FROM EACH EDGE. 2 VERTICAL STRAP SHORTWAY 5" FROM EACH EDGE. LOAD TO BE STRAPPED TO THE PALLET WITH ALL VERTICAL STRAPS.				
Length - (ID)	445	0	425	0	0	+/-3 mm					
Width - (ID)	330	0	318	0	0	+/-3 mm					
Height - (ID)	248	0	76	0	0	+/-3 mm					
Weight of Component	485	0	145	0	0	gms	Bottle Weight in gram	70.79	Box Net Weight	15.29	kg
Burst Factor	GOLDEN HRCT 150x3	NA	GOLDEN HRCT 150x3	NA	NA		Bottle Height in mm	75.39	Box Gross Weight	16.26	kg
Paper GSM		NA		NA	GSM		Bottles / Box	216	Layer / Box	7	Nos.
Bursting Strength	26 ECT	NA	26 ECT	NA	NA	kg/sq.cm	Pallet Type	'48x40 HT'	Pallet Weight	15	kg
Moisture Content	8	NA	8	NA	NA	%	Palletized Details				
Type of the Joint	PASTED	NA	PASTED	NA	NA		Container Type	40 FT HC OCEAN CONTAINER	UOM	40 FT HC OCEAN CONTAINER	UOM
Configuration Length x Width	09x08x03	NA	09x08x01	NA	NA	L X W	Layers / Pallet	8	Nos.	8	Nos.
Bottles / Box	216	NA	72	NA	NA	No.	Total Layers / Pallet	56	Nos.	56	Nos.
INSTRUCTIONS : 1. CARTON : RSC SW 150#-C-FLUTE NOTE: BOTTOM FLAPS TO BE CUT BACK 1/16". EXTENDED GLUE TAB SLANT CUT AND CRUSHED. HEAVY SCORE LINES. 2. CARTON SEALING INSTRUCTIONS : TOP SEALED PS TAPE - BOTTOM PS TAPE OR AUTO TAPE MACHINE . 3. CARTON PRINTING : SEE CARTON SPEC FOR PRINTING INFORMATION . 4. TRAY : TRAY RIGID SW 150#-B-FLUTE NOTE:BOARD MUST BE GOOD QUALITY. DIE CUT BLANKS NOTE:GLUE TABS ON THE LONG FLAP SIDE, PERFORATE ALL FOLDS AND CORNERS FOR EASY FOLD DOWN - CORRUGATIONS LONGWAY. .							Qty / Pallet	12096	Nos.	12096	Nos.
							Pallet Net Weight Approx -	1888	LB	856	Kg
							Pallet Gross Weight Approx -	2057	LB	933	Kg
							Total Pallet Height Approx -	88	Inch	2234	mm
							Pallet / Container -	20	Nos.	20	Nos.
							Box / Container -	1120	Nos.	1120	Nos.
							Qty / Container -	241920	Nos.	241920	Nos.
							Net Weight -	37762	LB	17.13	Tons
							Gross Weight -	41145	LB	18.66	Tons

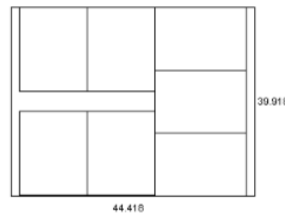
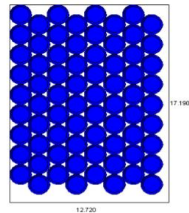
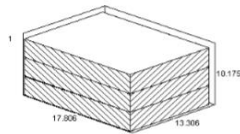
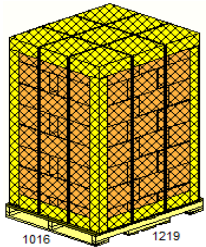

DISCLAIMER

This specification does not relieve the customer of their ultimate responsibility for the determination of the appropriate container. It is the customer's responsibility to select the appropriate packaging based upon all information at their disposal including the specific application, regulatory compliance, product compatibility and shipping requirements. WE HEREBY DISCLAIM AND EXCLUDE ANY EXPRESS OR IMPLIED WARRANTIES, INCLUDING WITHOUT LIMITATION THE IMPLIED WARRANTIES OF MERCHANTABILITY AND FITNESS FOR A PARTICULAR PURPOSE.

DISTRIBUTED BY:



REF NO.:

DWG32036

DESCRIPTION:

60 cc Glass Wide Mouth Packer, 38 mm