

BLACK DIAMOND®

Project Name: _____

Location: _____

Item #: _____

Qty: _____

Black Diamond 5-Burner Freestanding Gas Deep Fryer, 60 lb Oil Capacity, 105K BTU, in Stainless Steel

BDGF-ES60-NG



The Black Diamond 5-Burner Freestanding Gas Deep Fryer delivers high-performance frying with a robust 60 lb oil capacity, making it ideal for busy commercial kitchens seeking efficiency and reliable output. Featuring durable stainless steel construction and cast iron burners, it provides rapid heat-up, consistent cooking, and simple cleaning. Manual controls allow for precise temperature adjustment, while enhanced safety features like automatic shut off give operators peace of mind. This fryer supports natural gas use and a sturdy freestanding installation—all backed by the manufacturer's reliable warranty coverage.

FEATURES AND CONSTRUCTION

- Best-in-class, energy-efficient design with Energy Star Certification
- Heavy-duty stainless steel body and fry tank with cast iron burners enhance durability and simplify cleaning
- Delivers a total of 105,000 BTU output for rapid preheat and efficient cooking cycles
- Features five robust cast iron burners engineered for even heat distribution
- Manual control knobs allow precise adjustment of frying temperatures
- Operates efficiently on natural gas for dependable commercial performance
- Freestanding installation with 4 casters enables stability and flexible kitchen placement
- Manual ignition with automatic shut off for enhanced user safety and reliable startup
- Set up for use with natural gas (NG)

INCLUDED COMPONENTS

- (4) Casters
- (2) Baskets
- (1) Basket Support Rack
- (1) Basket Hanging Plate
- (1) Oil Drainage Extension Pipe

TEMPERATURE

Overall Temperature (Fahrenheit):

- Minimum: 200° - Maximum: 400°F

FRYER ACCESSORIES (OPTIONAL)

- Stainless Steel Cover
- Joiner Strips
- Splash Guard
- Fryer baskets available in a variety of sizes

3RD PARTY APPROVALS



WARRANTY (USA / CANADA)

One (1) Year Limited Warranty on Parts and Labor, Five (5) Year Warranty on Stainless Steel Fry Tank

Contact us for details at 1.877.368.2797





Black Diamond 5-Burner Freestanding Gas Deep Fryer

BDGF-ES60-NG

FRONT

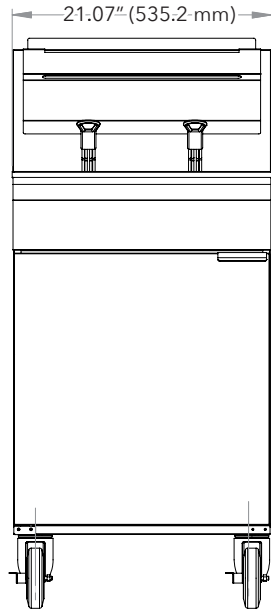

SIDE

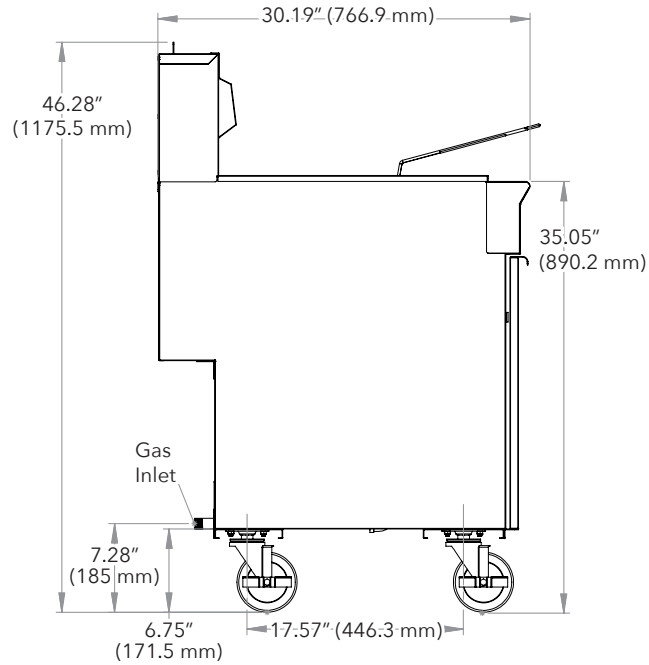

TOP

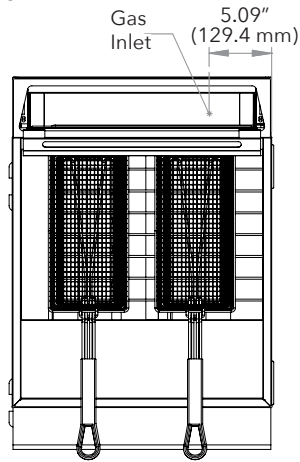

Gas

Capacity (lbs. of oil)	Temperature Range (Fahrenheit)	BTU / Hour	Assembled Dimensions (in)	Item Weight (lbs)	Shipping Weight (lbs)
60 lb	200° - 400°	105000	30.19" x 21.07" x 46.28"	176.4	205.1

ADDITIONAL INFORMATION

- Electricity not needed.
- Liquid Propane (LP) or Natural Gas (NG) units available. Field convertible from LP to NG and vice versa.
- Minimum supply pressure is 4" W.C. for natural gas and 10" W.C. for propane.
- Gas powered appliances must always be indoors, under an approved exhaust system with grease removal filters and a fire protection system.

Due to periodic changes in designs, methods, procedures, policies and regulations, the specifications contained in this document are subject to change without notice. While we exercise good faith efforts to provide information that is accurate, we are not responsible for errors or omissions in information provided or conclusions reached as a result of using the specifications. By using the information provided, the user assumes all risks in connection with such use.