

SEE DECORATION DETAIL

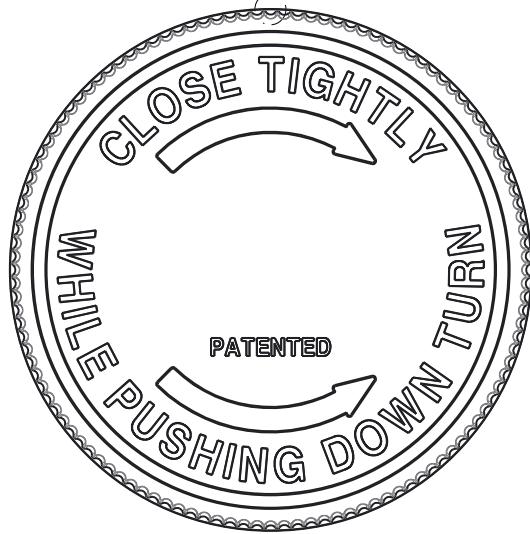

NOTES:

DIAMETERS TO BE TAKEN AS AVERAGE
6 TPI THREAD CONSTRUCTION

SEE DRAWING QIM-500-A105 FOR
SPECIAL FINISH CONSIDERATIONS

SUGGESTED APPLICATION TORQUE:
13-19 IN-LBS (1.5-2.1 N-M)

CAVITY NUMBER TO APPEAR ON INSIDE
TOP SURFACE OF BOTH OUTER AND
INNER CLOSURES

ENGLISH DIMENSIONS IN INCHES
METRIC DIMENSIONS IN (mm)

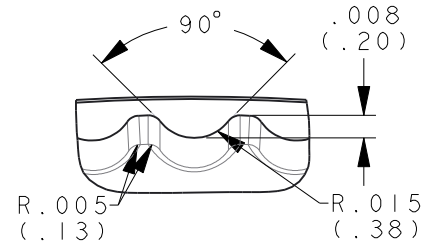
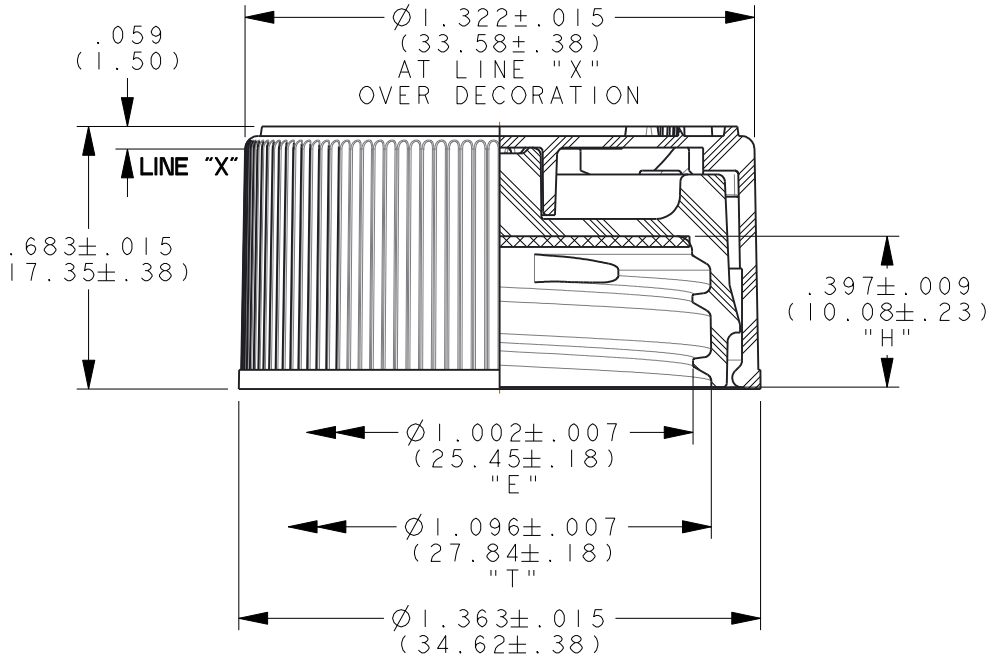

DECORATION DETAIL

REFERENCE ONLY
SCALE 15:1

120 EQUALLY
SPACED CUTS

Weights

Outer Cover w/ Text	2.4 g
Inner Closure	2.3 g

DISCLAIMER

THIS INFORMATION IS PROVIDED AS A GENERAL GUIDE, INCLUDING DIMENSIONS. IT IS THE CUSTOMER'S RESPONSIBILITIES TO SELECT THE PROPER CONTAINER FOR PRODUCT AND APPLICATION COMPATIBILITY.

DISTRIBUTED BY:



REF NO.:

DWG31035

DESCRIPTION:

28-400 PP Child Resistant Cap with F217 Liner

- This data sheet describes F-217® products
- This product is a three-ply co-extruded liner consisting of a foamed Low Density Polyethylene (LDPE) core sandwiched between two layers of solid Low Density Polyethylene

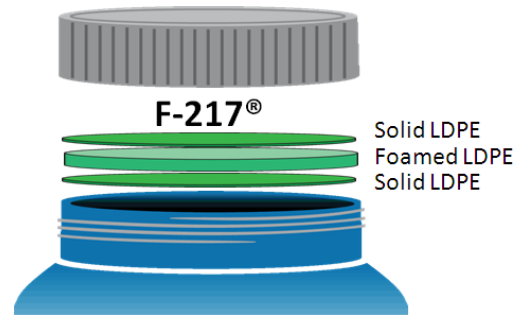

Typical Product Attributes

Construction

Structure	Solid LDPE / Foamed LDPE / Solid LDPE	Solid LDPE / Foamed LDPE / Solid LDPE
Color	White or as Specified	White or as Specified
Density		
for 20 ~ 30 mil (0,51 ~ 0,76 mm)	0,48 ± 0,03 g / cm ³	30 ± 2 lbs / ft ³
for 35 ~ 125 mil (0,89 ~ 3,18 mm)	0,40 ± 0,03 g / cm ³	25 ± 2 lbs / ft ³
Thickness Tolerance		
for 20 ~ 60 mil (0,51 ~ 1,52 mm)	± 0,127 mm	± 5 mil
for 65 ~ 90 mil (1,65 ~ 2,29 mm)	± 0,178 mm	± 7 mil
for 95 ~ 125 mil (2,41 ~ 3,18 mm)	± 0,254 mm	± 10 mil
Available Width		
for 20 ~ 60 mil (0,51 ~ 1,52 mm)	22,2 ~ 1016,0 mm	7/8 ~ 40 inch
for 65 ~ 125 mil (1,65 ~ 3,18 mm)	25,4 ~ 228,6 mm	1 ~ 9 inch
Width tolerance	± 1,6 mm	± 1/16 inch

Regulatory Compliance

FDA Compliance	21 CFR 177.1520 (Olefin Polymers) 21 CFR 177.1210 (Closures with Sealing Gaskets for Food Containers) 21 CFR 175.300 (Resinous and Polymeric Coatings)
Drug Master File (DMF)	2434
Other Compliances	USFDA Food Allergen Guidelines; California Proposition 65 Labeling Requirements; Limitations of Heavy Metals in Packaging per CONEG & EU 94/62/EC, Article 11

400 PP Child Resistant Push & Turn

Product Information Sheet

Product Description

This 28 mm push-and-turn child-resistant closure offers enhanced safety and usability. Designed with a fine-ribbed sidewall for better grip and text top opening instructions for optimal user experience. Features a modified buttress, or “M” style, thread profile for more precise closure-to-bottle thread contact. Available with a standard liner. Suited for the healthcare, nutraceuticals, beauty and personal care, and many other markets.



Features and Benefits

- Child-resistant and senior-friendly
- Stock and custom-made options
- Matching bottles or vials available for total package solutions
- Printing, highlighting and user-centered design to stand out on shelves
- Multiple manufacturing locations and vertical facilities
- Commissioning, Qualification, and Validation (CQV) process compliant

Product Information

Closure Diameter	28 mm
Closure Sidewall	Fine Ribbed
Closure Top	Text
Neck Thread	400
Case Count	2600
Case Weight	31 Pounds
Cases per Pallet	21
Diameter	28 mm
Material	PP
Weight	0 g