



# PRESTIGE<sup>®</sup> PRO

## Owner's Manual

PRO665VX

Grills illustrated in this manual may differ from model purchased.

We would like your feedback!  
Visit [Napoleon.com](https://www.napoleon.com) to write a review.



Apply Serial Number

# CONGRATULATIONS ON YOUR NAPOLEON® GRILL!

You've Just Upgraded Your Grilling Game.



## USE ONLY OUTDOORS IN A WELL VENTILATED AREA.

### ⚠️ DANGER! ⚠️

#### IF YOU SMELL GAS:

- Shut off gas to the appliance.
- Extinguish any open flame.
- Open lid.
- If odor continues, keep away from the appliance and immediately call your gas supplier, or fire department.

### ⚠️ WARNING! ⚠️

Do not try to light this appliance without reading the “LIGHTING” instructions section of this manual.

Do not store or use gasoline, or other flammable liquids or vapors in the vicinity of this or any other appliance.

An L.P. (propane) cylinder not connected for use must not be stored in the vicinity of this or any other appliance.

If the information in these instructions is not followed exactly, a fire or explosion may result and cause property damage, personal injury, or death.



## OUR GOAL IS TO MAKE YOUR GRILLING EXPERIENCE BOTH MEMORABLE AND SAFE.



Please read this Owner's Manual before using the appliance to avoid property damage, personal injury, or death.



Remove all packaging material, promotional labels and cards from the grill before use.



Alert adults and children about the hazard of hot surface temperatures.



Children should be supervised to ensure that they do not play with the appliance.

### NOTICE TO INSTALLER:

Leave these instructions with the grill owner for future reference.

### NOTICE TO CONSUMER:

Keep these instructions for future reference.

# Welcome to NAPOLEON®!

## Safety First

### WARNING!

#### General Information

This grill should be installed in conformity with local codes. If a rotisserie motor is used, it must be electrically grounded in accordance with local codes. If an external electrical source is utilized, the appliance must also be grounded in accordance with local codes.

### WARNING!

#### Storage & Disuse

Turn off gas at the gas cylinder or gas supply valve. Disconnect the hose between the propane cylinder and grill. Remove the propane cylinder and store outdoors in a well ventilated space away from children

Unplug from the outlet when not in use and before cleaning. DO NOT store gas cylinders in a building, garage, shed, or any other enclosed space. Disconnect the fixed-fuel supply hose from the supply when storing the grill indoors.

Place dust cap on cylinder valve outlet whenever the cylinder is not in use. Only install the type of dust cap on the cylinder valve outlet that is provided with the cylinder valve. Other types of caps or plugs may result in leakage of gas.

### WARNING!

#### Operation

Leak test this grill before each use, annually and when any gas components are replaced. Follow the lighting instructions carefully. Do not use this grill for purposes other than intended.

Do not operate this grill with a damaged cord, plug, or after the grill malfunctions or has been damaged in any manner. Contact NAPOLEON authorized dealer for repair. If the supply cord is damaged, it must be replaced by the manufacturer, its service agent or similarly qualified persons in order to avoid a hazard.

This appliance can be used by children aged from 8 years and above and persons with reduced physical, sensory or mental capabilities or lack of experience and knowledge if they have been given supervision or instruction concerning use of the appliance in a safe way and understand the hazards involved. Children shall not play with the appliance. Cleaning and user maintenance shall not be made by children without supervision.

### WARNING!

#### Installation & Assembly

Assemble this grill exactly as instructed in the Assembly Guide. If the grill was assembled in-store, review the assembly instructions to ensure it is done correctly. This grill is not intended to be installed in or on boats or installed in or on recreational vehicles.

Perform the required Leak Test before operating the grill. Do not modify this grill under any circumstances. Allow grill to cool before installing or removing parts. Do not use a cylinder that is not equipped with the appropriate valve connection. Only use the pressure regulator and hose assembly supplied with this grill or replacement parts specifically recommended by NAPOLEON.

**⚠ WARNING!****Electrical Precautions**

To protect against electric shock, do not immerse the cord or plugs in water or other liquids. Do not let the cord hang over the edge of a table or touch hot surfaces. When connecting, first connect the plug to the grill, then plug the grill into the outlet.

The appliance shall be supplied through a residual current device (RCD) with a rated residual operating current not exceeding 30 mA. Never remove the grounding plug or use with an adapter.

This appliance incorporates an earth connection for functional purposes only. Use only extension cords suitable for outdoor use and compliant with EN standards.

If the electrical supply cord is damaged, it must be replaced by a Napoleon authorized dealer, its service agent, or a similarly qualified person to avoid a hazard.

**⚠ WARNING!****Correct Product Disposal**

This marking indicates that this product should not be disposed with other household wastes throughout the EU. To prevent possible harm to the environment or human health from uncontrolled waste disposal, recycle it responsibly to promote the sustainable reuse of material resources. To return your used device, please use the return and collection systems or contact the retailer where the product was purchased. They can take this product for environmental safe recycling.

## CONTENTS

<b>Welcome to NAPOLEON®!</b>	<b>4</b>
Safety First	4
<b>Full System Features</b>	<b>8</b>
<b>Getting Started</b>	<b>10</b>
Safety Symbols You Should Know	10
Safe Operating Practices	10
Locating Your Grill	12
Gas Connections	13
Leak Test	17
Quick Start Instructions	18
Napoleon Connectivity	19
Pairing Mode Activation Guide	21
<b>System Overview and Operation</b>	<b>22</b>
Control Features (If Equipped)	22
Lighting Your Grill	29
How to Use the Rotisserie	33
Storage	34
The Grilling Experience Checklist	35
<b>ACCU-PROBE® Cook Assist</b>	<b>36</b>
Compatible Devices	36
Display Overview	36
Display Operation	37
Safeguards	39
Clearance	39
<b>Infrared Grilling Guide</b>	<b>40</b>
<b>Smoker Guide</b>	<b>42</b>
Quick Smoking Tips	42
<b>Operation</b>	<b>46</b>
Door	46
Tool Overview	46
Wood tray	47
Setting Up Your Smoker	47

---

<b>Cleaning Instructions</b>	<b>48</b>
Cleaning the Smoker Box	48
Cleaning your Grill for First Time Use	49
Stainless Steel Grids	49
Infrared Side Burner	49
Inside of the Grill	50
Drip Pan	51
Thermocouples	51
Control Panel	52
Aluminum Castings	52
Outside Grill Surface	52
Insect Screen and Burner Ports	53
Temperature Probes	54

---

<b>Maintenance Instructions</b>	<b>55</b>
General Requirements	55
Combustion Air Adjustment	55
Stainless In Harsh Environments	56

---

<b>Troubleshooting</b>	<b>58</b>
Lighting Problems	58
Noises and Flare-ups	58
Gas Flow	59
Peeling Paint	60
Infrared Burner Flashes Back	60
Smoker	61
Pairing the App with the Appliance	63

---

<b>Diagram for Electrical Connections</b>	<b>65</b>
---	-----------

---

<b>Warranty</b>	<b>66</b>
-----------------	-----------

# Full System Features

Dual-level Stainless Steel Sear Plates for consistent even heating and vaporizing drippings for more flavourful food

Rear Infrared Rotisserie Burner to enjoy succulent rotisserie meals

Includes a durable silicone mat

7" Wi-Fi & Bluetooth® enabled display with custom temperature monitoring settings.

Easily adjustable cabinet doors.

Supplied with three wired probes for reliable performance

**LED SPECTRUM NIGHT LIGHT™** Control Knobs with safety glow.

Instant **JETFIRE™** Ignition for quick and east start-up.

**ULTRA-GLIDE™** Propane tank storage tray (propane models only)

Spacious drawers equipped with adjustable dividers.

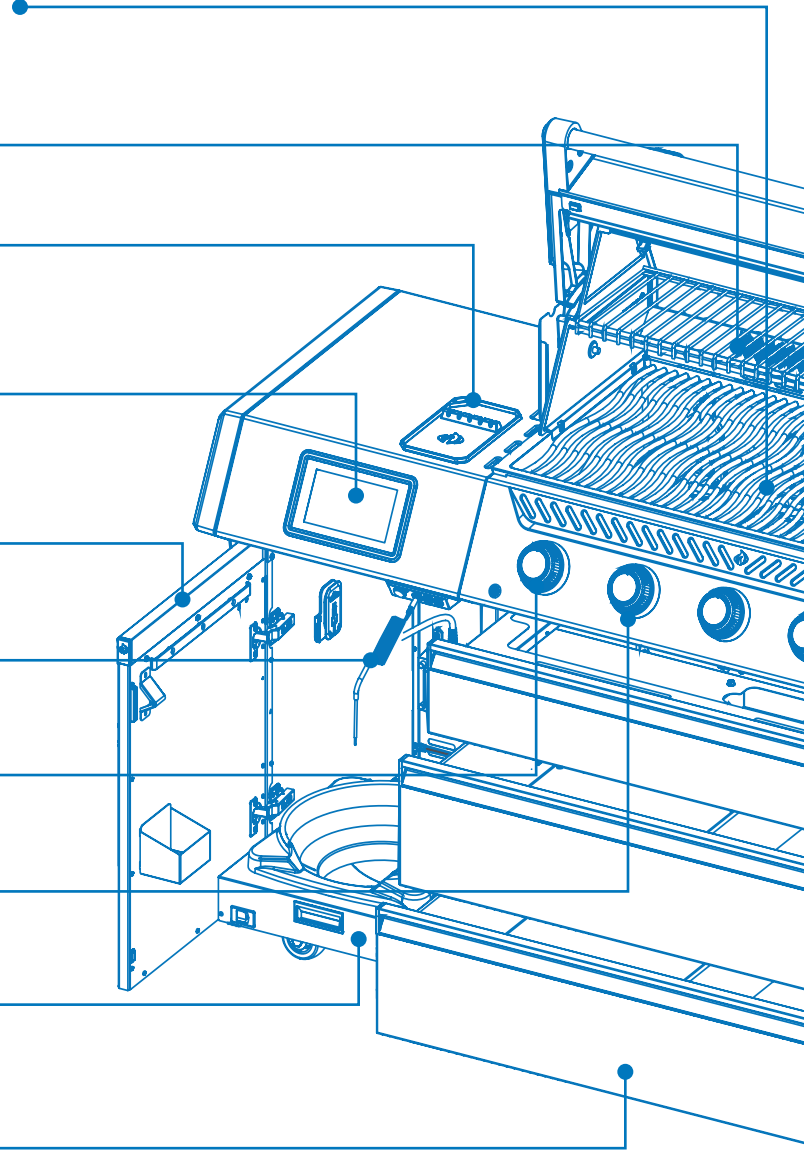

## IMPORTANT!

The grills illustrated in this Owner's Manual may differ from the model you purchased.  
**Featured model:** PRO665VX Propane version.

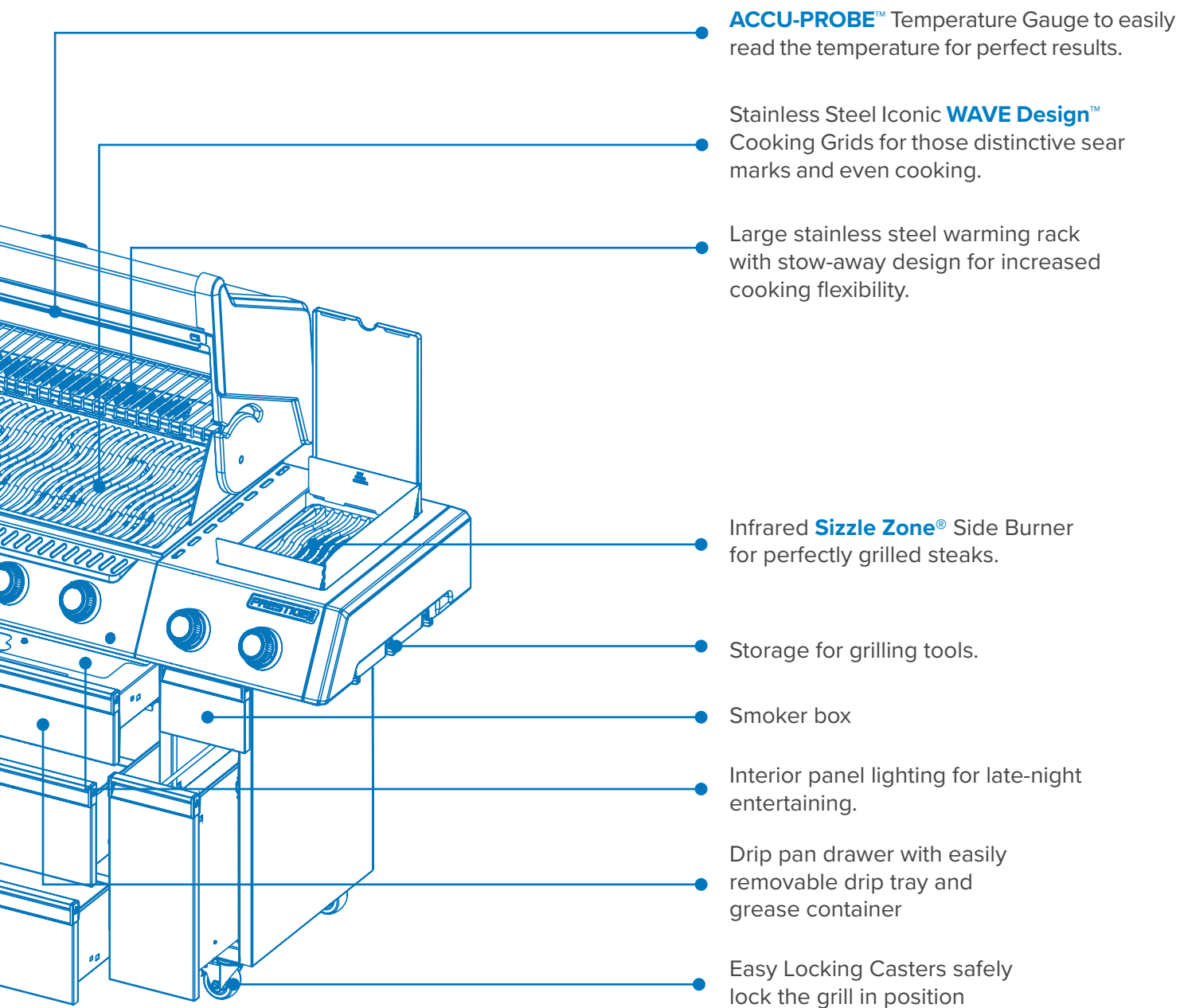

# Getting Started

## Safety Symbols You Should Know



### DANGER!

Advises of a hazard that could result in a fire, explosion, death or serious physical injury.



### WARNING!

Advises of a hazard that could result in minor physical injury or property damage.



Do not smoke while performing a gas leak test. Sparks or flames will cause a fire, explosion, damage to property, serious physical injury, or death.



Never use an open flame to check for gas leaks. Sparks or flames will cause a fire, explosion, damage to property, serious physical injury, or death.



### CAUTION! Hot surface.



Immediately shut off the gas supply and disconnect.



Wear safety glasses.



Wear protective gloves.



Important Information.

## Safe Operating Practices

- Do not route the hose underneath the drip pan. Maintain proper hose clearance from the bottom of the unit.
- Ensure the sear plates are positioned according to the sear plate installation instructions.
- Turn off burner controls before opening the gas cylinder valve.
- Do not light the burners with the lid closed.
- Do not operate the rear burner simultaneously with the main burners.
- Do not close the side burner lid while operating or when hot.
- Do not deep fry food on the side burner.
- Do not adjust the cooking grids while the grill is in operation or when hot.
- Do not move the appliance during use.
- Turn off the gas supply at the source after use.
- Do not modify the appliance.
- Perform maintenance only when the grill is cool.
- Do not store lighters, matches, or any other combustibles inside the enclosure or condiment tray.



### BE CAREFUL!

The lid of the grill and the entire firebox can become very hot when in use.

- Keep all electrical supply cords and fuel supply hoses away from heated surfaces.
- Clean the grease tray, drip pan, and sear plates regularly to prevent build-up and grease fires.
- Inspect and clean the infrared burner and main burner venturi tubes regularly to keep them free from spider webs and other obstructions.
- Do not allow cold water (rain, sprinkler, hose, etc.) to contact the heated grill. An immediate temperature change will damage the porcelain and crack the ceramic burners.
- Do not use a pressure washer to clean any part of the grill.
- Do not place the grill where it may be exposed to high winds, especially when the wind can come from directly behind the grill.
- Ensure the appliance is kept at a safe distance from flammable constructions.
- Never cover more than 75% of the cooking surface with solid metal.
- Keep the appliance away from flammable materials while in use.
- The minimum ambient operating temperature for safe use is 0 °F (-17.8 °C).
- Do not store anything inside the smoker box, besides the wood chip tray.

### ! IMPORTANT!

- Always maintain proper clearances to combustibles:

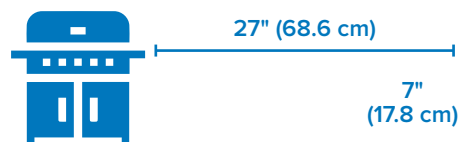

### ! WARNING!

- The hook-up and installation of the gas and hose connection must be performed by a licensed gas fitter, and leak tested before operating the grill.
- Accessible parts may be very hot. Keep young children away.
- Keep fuel supply hoses away from high-temperature surfaces, sharp edges, and dripping grease.

## Locating Your Grill

Ensure that the location for your gas grill meets all clearance requirements to adjacent combustibles.

Always maintain proper clearances to combustibles: 27" (68.6 cm) to the rear and 7" (17.8 cm) to the sides.

This appliance is intended for use on an outdoor patio or in your yard.

- Use the appliance only in an above-ground, open-air location with natural ventilation and no stagnant areas. Ensure gas leakage and combustion products are dispersed quickly by wind and natural convection.
- Do not use the appliance in a building, garage, or other enclosed space.
- Do not integrate the appliance into built-in or slide-in construction.
- Do not block ventilation openings in the cylinder enclosure.

Any enclosure in which the appliance is used must meet one of the following requirements:

- The appliance is considered outdoors if installed in a shelter with walls on three sides but no overhead cover (**Fig 1**).
- An appliance is considered to be outdoors if installed in a shelter with an overhead cover and no more than two sidewalls.
  - » The sidewalls may be parallel, as in a breezeway, or at right angles to each other. (**Fig 2 & Fig 3**).
- An appliance is considered outdoors if installed in a shelter with three sidewalls and an overhead cover, as long as 30% or more of the horizontal periphery of the enclosure is permanently open and unrestricted. (**Fig 4 & Fig 5**).

### ! IMPORTANT!

- All openings must be permanently open.
- Sliding doors, garage doors, windows, or screened openings are not considered as permanent openings.

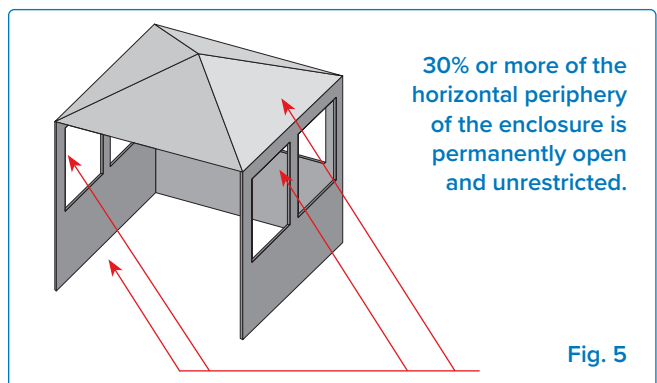
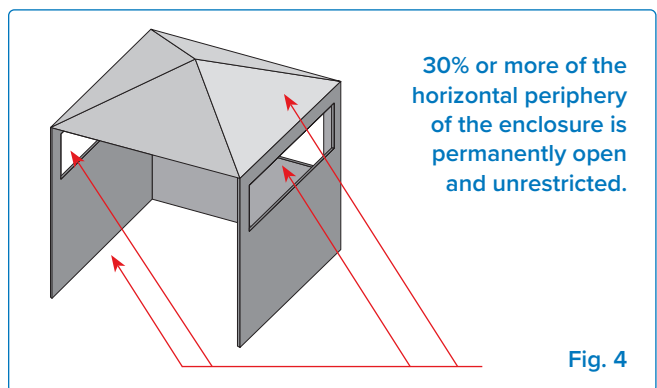
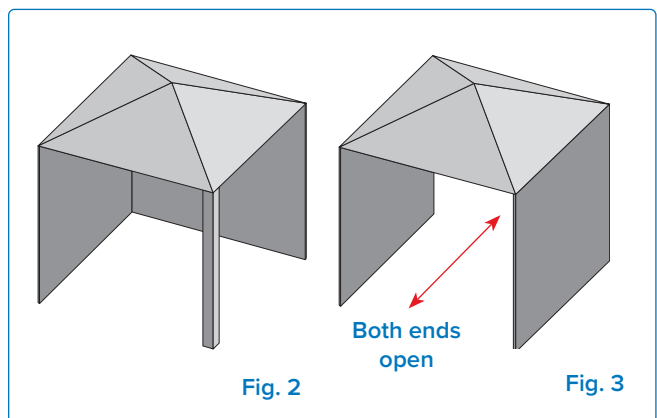
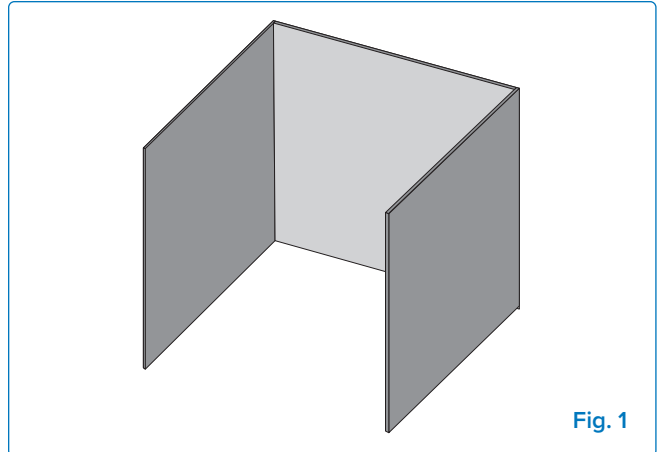

## Gas Connections

### To a Gas Cylinder: Option 1

Use a propane cylinder of minimum 6 kg or a butane cylinder of 13 kg constructed and marked in accordance with national and regional codes. Ensure that the cylinder can provide enough fuel to operate the appliance. If in doubt, check with your local gas supplier.

Use a gas pressure regulator and hose supplied by Napoleon; if not included, use a regulator and hose that meet European Norm and regional codes. The recommended length of the hose is 0.9 m. The hose must never be longer than 1.5 m.



#### NOTE:

- The hose should be replaced before the expiry date printed on it.

Only place cylinders within the maximum width and height dimensions inside the enclosure on the bottom shelf. Cylinders that surpass the maximum dimensions must be placed outside the enclosure on level ground. Refer to the diagram below for specific measurements.

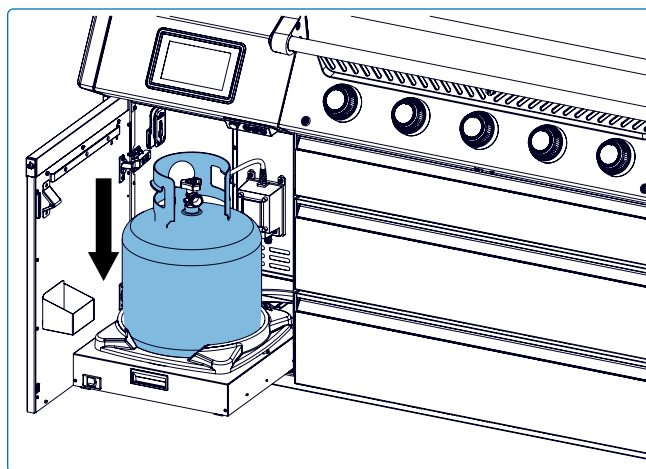
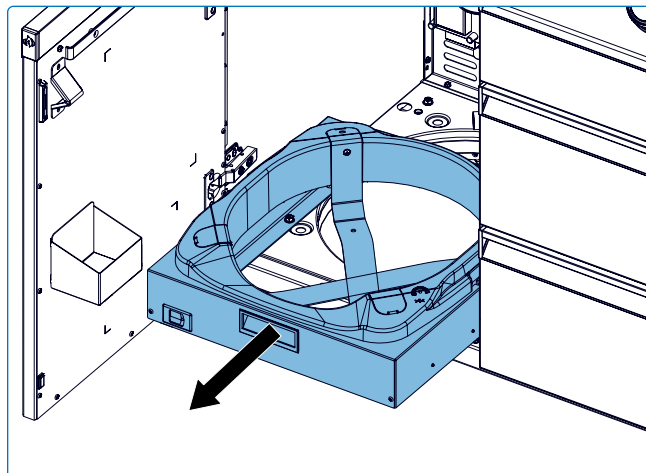

#### WARNING!

- Do not store a spare gas cylinder under or near the appliance.
- Do not use a gas cylinder that is more than 80% full.
- Follow all specifications and instructions precisely to prevent fire, explosion, property damage, personal injury, or death.
- Disconnect the grill and its individual shutoff valve from the gas supply piping system during any pressure testing in excess of ½ psi (3.5 kPa).

## Hook-up and Installation

- Check the cylinder for dents or rust, and have it inspected by your propane supplier.
- Never use a cylinder with a damaged valve.
- Place the cylinder in its designated area on the bottom shelf.
- Ensure the gas regulator hose is straight and free of kinks or bends, as these can restrict gas flow.
- Remove the cap or plug from the cylinder fuel valve.
- Tighten the regulator to the cylinder valve.
- Ensure the hose does not contact with the drip pan or any high temperature surfaces of the grill because it will melt and cause a fire.
- Ensure the cylinder is not left exposed to extreme heat or direct sunlight.
- Leak test all joints prior to operating the grill. See **“Leak Test”** section.
- The cylinder must be mounted so that the pressure relief valve outlet is not oriented toward the normal operating position of the user.



### NOTE:

- Inspect the LP gas cylinder valve seal for cracks, wear, or deterioration each time the cylinder is replaced or refilled.
- Any LP gas cylinder showing signs of damage or deterioration, including visible cracks and pitting, must be returned unused to the seller.

## Replacement

The entire process of changing the gas cylinder must be done away from any sources of ignition.

1. Close the cylinder fuel valve.
2. Detach the regulator from the cylinder valve.
3. Remove the cylinder from the bottom shelf and replace with a new cylinder.
4. Follow Hook-up instructions.

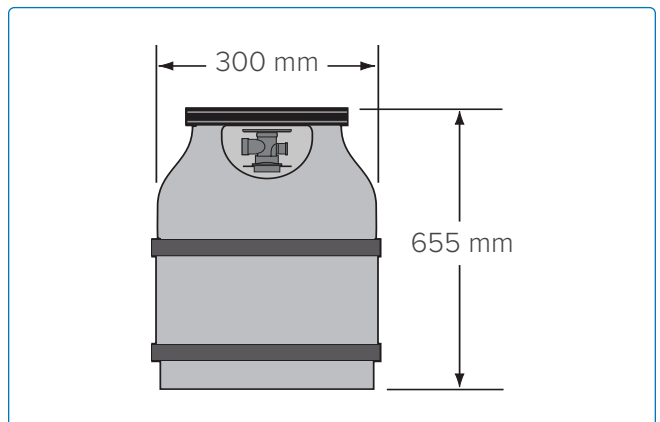
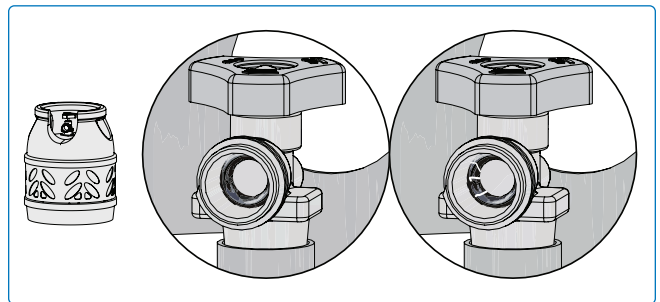
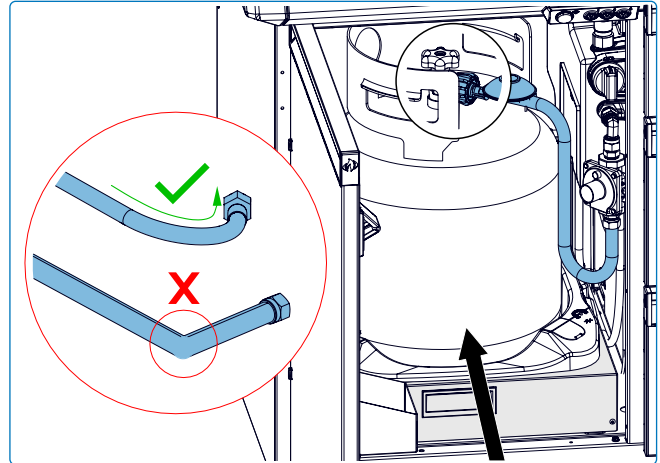

### NOTE:

- Place cylinders only within the maximum width and height dimensions on the bottom shelf inside the enclosure. Cylinders that exceed these dimensions must be placed outside the enclosure on level ground. Refer to the diagram above for specific measurements.

## To a House Gas Supply Line: Option 2

- If the grill is to be connected directly to a house propane gas supply line, disconnect and discard the supplied hose and regulator assembly and follow house gas supply line hook-up instructions. An approved hose is available from your Napoleon grill dealer.
  - Before installation, ensure that the local distribution conditions (identification of the type of gas and pressure) and the adjustment of the appliance are compatible.
  - An isolation valve (or valves) must be fitted adjacent to the appliance which, when closed, allow the complete burner and control assembly to be disconnected for maintenance or repair in accordance with national regulations.
  - A gas supply hose and quick disconnect designed for natural gas and certified for outdoor use are included with natural gas grills.
  - Gas plumbing must supply the appropriate pressure to the inlet of the grill. See "Technical Data" for specifications.
  - Piping and valves upstream of the quick disconnect are not supplied.
  - The gas pipe must be sized to supply the heat input specified on the rating plate, based on the length of the piping run.
  - Gas connection size (Internal regulator): 11/16" (1.75 cm).
1. Hook-up to a gas supply line must be performed by a licensed gas fitter and leak tested before operating the grill.
  2. Do not route the hose in close proximity to the drip pan or over top of the back panel.
  3. Ensure the hose does not contact any high temperature surfaces.

### Quick Disconnect

- Do not install the quick disconnect in an upward direction.
- A readily accessible manual shut-off valve must be installed upstream of the quick disconnect, and as close to it as possible.
- Connect the flared end of the hose to the fitting on the end of the manifold tube or flex tube (if applicable).
- Tighten using two wrenches. Do not use thread sealer or pipe dope.
- Leak test all joints prior to operating the gas grill. See "**Leak Test**".



### WARNING!

- Close the individual shutoff valve to isolate the grill from the gas supply piping system during any pressure testing equal to or less than ½ Psi (3.5 kPa).
- Check the hose for evidence of excessive abrasion, melting, cuts or cracks. If the hose is damaged, it must be replaced with an assembly specifically recommended by NAPOLEON.



### BE CAREFUL!

The lid of the grill and the entire firebox can become very hot when in use.

## Technical Data

The following table lists gross heat input, gas usage values and orifice sizes corresponding to each burner per Gas Category:

		Orifice Size		Gross Heat Input (Total)		Gas Usage (Total)	
		I	II	I	II	I	II
PRO665VX	Main	1.02 mm	-	20.0 kW G30 17.5 kW G31	-	1455 g/h	-
	Rear	1.25 mm	-	5.7 kW G30 5.0 kW G31	-	415 g/h	-
	Side	#56	-	5.0 kW G30 4.5 kW G31	-	364 g/h	-

The following table lists all certified gases and pressures. Verify the information on the rating plate corresponds with this list.



**NOTE:** Only use regulators that supply the pressure listed here.

Gas Category	3P(30)	3P(37)	3P(50)	3B/P(30)	3+(28-30/37)	3B/P(50)
Orifice Sizes	I	I	I	I	I	I
Gases / Pressures	G31 at 30 mbar	G31 at 37 mbar	G31 at 50 mbar	G30/G31 at 30 mbar	G30 at 28 - 30 mbar/ G31 at 37 mbar	G30/G31 at 50 mbar
Countries	FI, NL, RO	BE, CH, CZ, ES, FR, GB, GR, HR, IE, IT, LT, NL, PL, PT, SI, SK	AT, CH, CZ, DE, GR, NL, SK	BE, BG, CY, DK, EE, FI, FR, GB, GR, HR, HU, IT, LT, MT, NL, NO, RO, SE, SI, SK, TR	BE, CH, CY, CZ, ES, FR, GB, GR, IE, IT, LT, PT, SI, SK, TR	AT, CH, DE, FR, SK



### WARNING!

- Check the hose for evidence of excessive abrasion, melting, cuts or cracks. If the hose is damaged, it must be replaced with an assembly specifically recommended by Napoleon.

## Leak Test

### Why and When to Leak Test?

A leak test confirms no gas is escaping after you connect the hose to the gas supply.

Each time the tank is refilled and reinstalled, ensure that there are no leaks in the fitting where the regulator connects to the tank.

Leak test this grill before use, annually, and when any gas components are replaced.

### Leak Test Steps

1. Do not smoke while performing the test.
2. Remove all sources of ignition.
3. Turn all burner controls to the OFF position.
4. Turn the gas supply valve ON.
5. Brush a half-and-half solution liquid soap and water onto all joints and connections of the regulator, hose, manifolds, and valves.
6. Bubbles indicate a gas leak.

### If you Find a Leak

1. Tighten any loose joints.
2. If the leak cannot be stopped, immediately shut off the gas supply and disconnect the grill.
3. Have the grill inspected by a certified installer, or dealer.
4. Do not use the grill until the leak has been fixed.

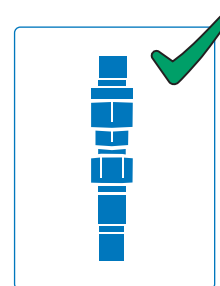
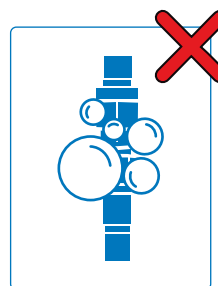
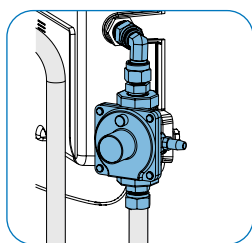
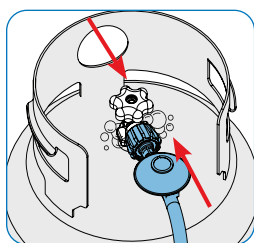
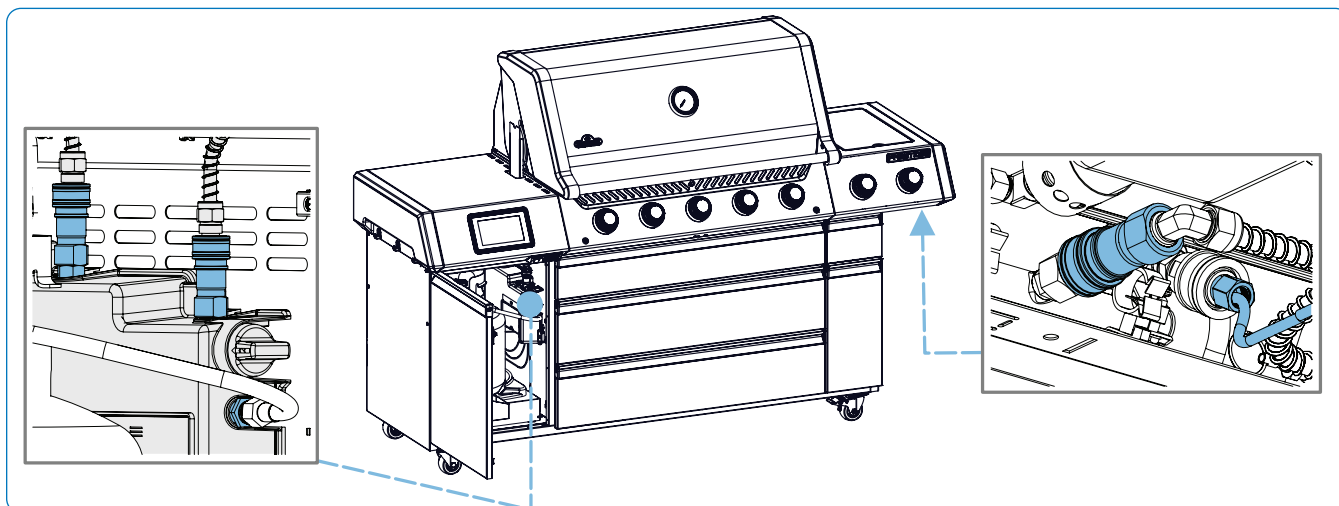

### **DANGER!**

- Never use an open flame to check for gas leaks. Sparks or flames will cause a fire, explosion, damage to property, serious physical injury, or death.
- Only use the pressure regulator and hose assembly supplied with the grill, or one in conformity with local codes.

## Quick Start Instructions

1

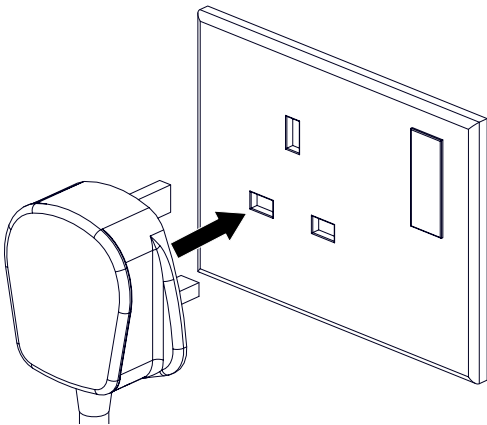

Plug directly into a grounded GFI (Ground Fault Interrupter) outlet. Consult an electrician if unsure.

2

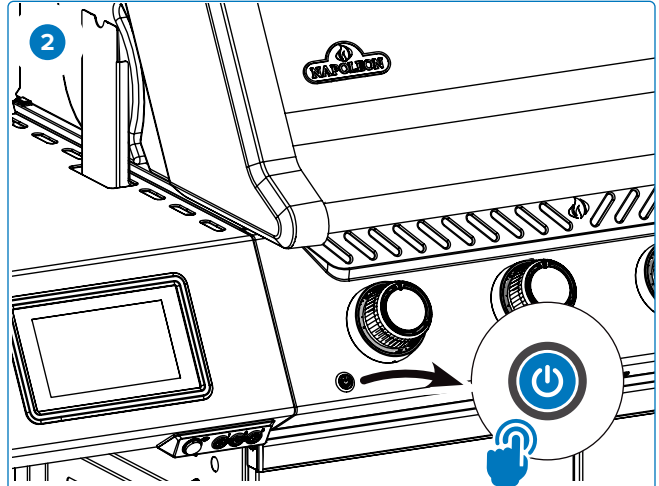

Press the power button to activate the unit.

3

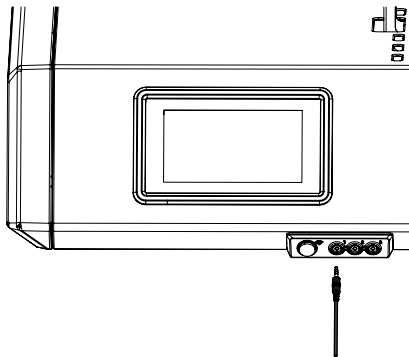

Remove the protective plastic and plug one or more probes into your appliance.

4

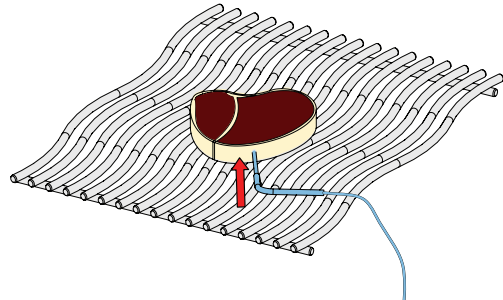

When using meat probes, ensure that the tip of the probe is inserted into the thickest section of the food, avoiding bones or fat.

5

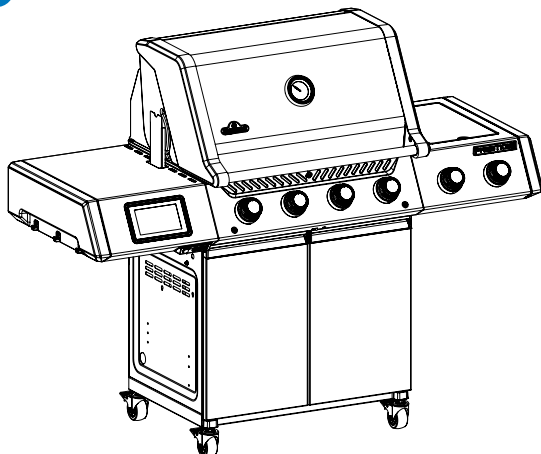

Follow the instructions in the next section to connect to the Napoleon Home App. Enjoy your meal!

## Napoleon Connectivity

# NAPOLEON HOME APP

## HOW DOES IT WORK?

Access your appliance remotely by downloading the **Napoleon Home App** from the App Store or Google Play.

In order to access the app, you will be required to create an account by following the instructions listed within the app (see below for details).



By pairing your appliance to the **Napoleon Home App** via Wi-Fi, you gain control to all modes and functions of the appliance.

All notifications and alarms are sent through the app to keep you connected with ease.



Scan this QR code for direct access to the **Napoleon Home App** website.



## LET'S GET STARTED

### 1 Register

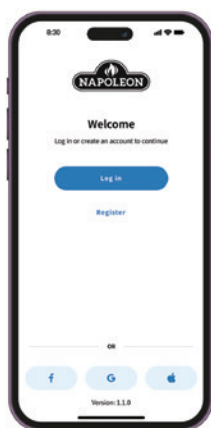

Register an account with the **Napoleon Home App** OR sign-in using your Facebook, Google, or Apple account information.

### 2 Create

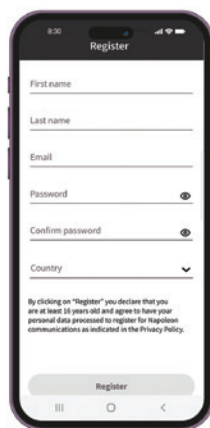

Enter user information and create a password for the account. Select the country in which the appliance is located.

### 3 Almost there



The information entered in Step 3 will be registered to the **Napoleon Home App** and a confirmation will be sent to the email provided.

### 4 Confirm

Open email inbox and select the confirmation link. **Note:** The confirmation link must be opened on the device that the Napoleon Home App is installed on.

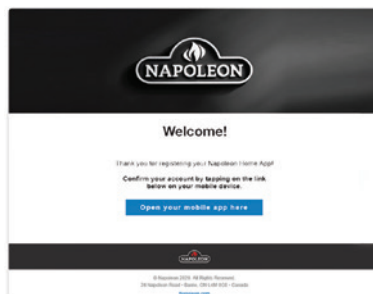

### 5 Re-confirm



If no email is found, click “Re-Send Confirmation Link” and check spam folder.

## ADDING A DEVICE

### 1 Power On

Ensure your device is turned on by short pressing the power button on the control panel. See Pairing Mode Activation Guide for further steps.



### 2 Add Device

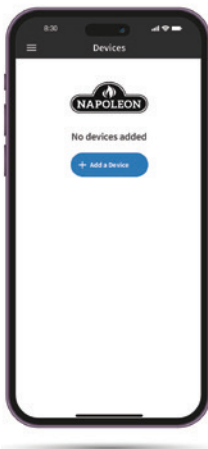

Select “Add Device” and accept the permissions.

### 3 Search



Search for devices and select the device from the list.

### 4 Network Connection

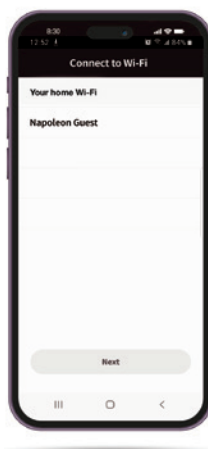

Select the Wi-Fi network and enter your credentials.

### 5 Add Nickname



Enter a custom name for your device, or proceed with default name provided.

### 6 Success!



## Pairing Mode Activation Guide

To enable pairing mode on the Grill, follow either of the two options below. Pairing mode allows you to provision the Grill, using a mobile app to connect it to the cloud/app. The control panel button will flash in white when pairing mode is successfully activated.

### Option 1: Reset Network via Wi-Fi Settings

#### Action:

Activate pairing mode by resetting the network in Wi-Fi settings.

#### Steps to Perform:

1. Turn on the display screen and wait until the startup process is complete.
2. Reset the Network using the Wi-Fi icon:  
Tap the Wi-Fi icon on the display screen.  
In the Wi-Fi menu, select **Reset Network**.

#### Result:

The button on the control panel will start flashing in white, indicating that the system is in pairing mode. You can now provision the device using the mobile app to complete the setup.

### Option 2: Long Press Activation

#### Action:

Activate pairing mode through a long press on the Control panel Power Button.

#### Steps to Perform:

1. Ensure the display screen is active.
2. Long press the control panel power button continuously for **10 seconds**.

#### Result:

The control panel button will begin flashing in white, indicating that the system is in pairing mode. At this point, you can proceed with provisioning the device through the mobile app.



#### NOTE:

- Choose either of the above option to activate pairing mode and connect the system to the cloud.

# System Overview and Operation

## Control Features (If Equipped)

Modern control features enhance precision cooking by automating heat management, optimizing fuel efficiency, and ensuring consistent results. These advanced features allow you to customize your experience based on your cooking needs. Whether searing at high heat, maintaining low-and-slow smoking, or using presets for different foods, these advanced controls bring convenience and accuracy to your outdoor cooking.

Your Prestige® PRO Series Grill is equipped with a state-of-the-art control system that is Wi-Fi-capable and integrated within the Napoleon Home App ecosystem.

Before you begin using the grill, familiarize yourself with the different features of the display.

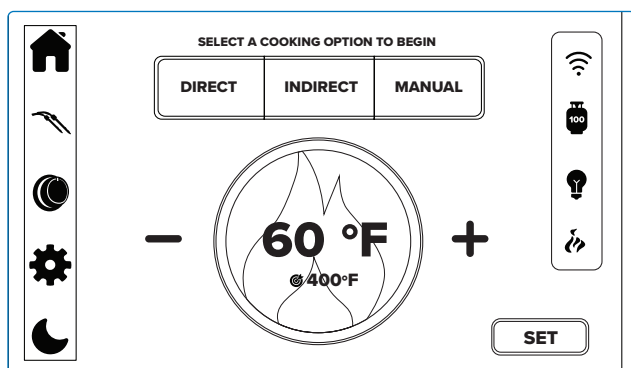

For your safety, cooking functions cannot be started remotely. You must be physically present at the grill to activate any burner or cooking mode. This ensures proper supervision during ignition and helps prevent accidental or unattended activation of the appliance.

### Initialization



Plug the grill into a properly grounded, outdoor-rated electrical outlet to utilize digital controls and peripheral electronic features.

Short-press the power button on the left side of the control panel to initiate the startup sequence.



### NOTE:

- To install additional languages, insert the SD card while the unit is off, then power on and follow on-screen prompts. Remove the card after the update completes and restart the unit. See the **Assembly Guide** for more details.

## Automatic Modes

### Direct Mode

#### *High-heat searing for quick-cooking foods.*

Place food directly over the heat on the cooking grids for a perfect sear, locking in juices and flavour. Ideal for hamburgers, steaks, chicken, and vegetables. For thicker cuts, sear first, then lower the grill temperature or switch to Indirect Mode to finish cooking to your desired doneness.

All main burners automatically adjust to maintain your set temperature between 320°F – 580°F (160°C – 290°C), ensuring consistent heat control throughout the cooking process.

- Select the **DIRECT** cooking option on the display.

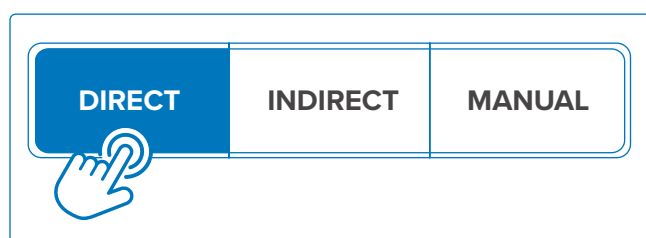

- Use the +/- icons on the display to select your target temperature.

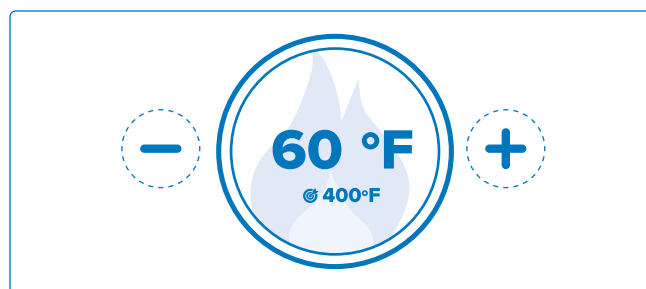

3. Press Set.



4. Wait for the display to indicate that the burners are ready to ignite. All main burner control knobs will begin flashing white, indicating that all main burners must be manually ignited.



5. Follow the instructions in "**Lighting Your Grill**" section to ignite all main burners. Adjust all control knobs precisely to their highest setting.



**IMPORTANT!**

- If any burner is adjusted to anything other than its maximum setting, the system will revert to **Manual Mode**.

6. Place your food once the grill is pre-heated to your satisfaction, and close the lid.

**Indirect Mode**

*Slow, even cooking at lower temperatures with circulating heat.*

This mode is ideal for larger cuts of meat or foods prone to flare-ups, such as roasts, whole chickens, and turkeys. The lower temperature and extended cooking time help produce tender, flavorful results.

Specific main burners adjust automatically to maintain a target temperature range of 220°F – 380°F (110°C – 190°C) for consistent heat control.

1. Select the **INDIRECT** cooking option on display.

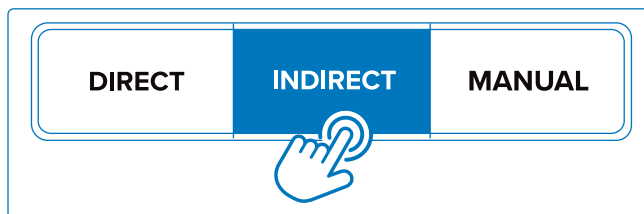

Specific main burner control knob lights will begin flashing white, indicating which main burners must be manually ignited.



2. Follow the instructions in "**Lighting Your Grill**" to ignite the indicated main burners. Adjust all control knobs precisely to their highest setting.



**IMPORTANT!**

- If any burner is adjusted to anything other than its maximum setting, the system will revert to **Manual Mode**.

3. Use the +/- icons on the display to select your target temperature.

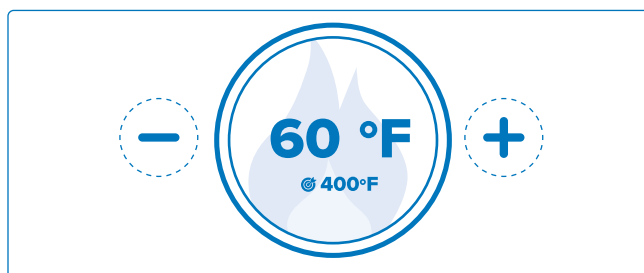

4. Place your food over an area without a lit burner beneath. Close the lid.

5. If desired, introduce a high heat sear at the end of your indirect cooking session by changing to Direct Mode. Alternatively, utilize the infrared side burner.

## Manual Mode

### Maintain full control over each burner.

Use the control knobs to adjust heat levels independently, setting them to any position based on your cooking needs. This mode is perfect for customized grilling and managing multiple heat zones for different foods. Manual mode provides ultimate flexibility, allowing you to fine-tune your grilling experience without preset temperature automation while still accessing smart auxiliary features and other powered functions.

1. Select the **MANUAL** cooking option on the display.

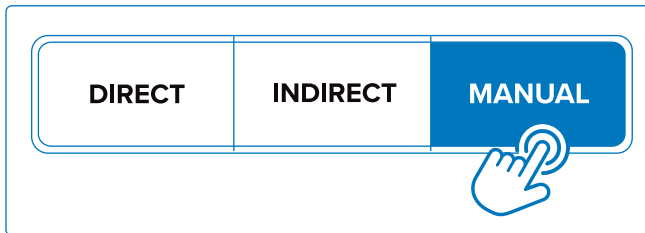

2. The leftmost main burner control knob light will begin flashing white, indicating that it must be manually ignited.



### IMPORTANT!

- This burner must remain lit throughout your use of Manual Mode, or the system will shut down.



3. Follow the instructions in "**Lighting Your Grill**" section to ignite the indicated main burner.
4. Follow the same procedure to ignite any others main burners as desired. Modulate control knob settings to achieve your preferred heat zones.

## Traditional Mode

### A simplified grilling experience without electronic assistance.

The grill can function as a fully manual, traditional gas grill with no digital gas controls. While features such as automatic adjustments are disabled, core grilling functions remain fully operational. Ensuring that you can still cook with confidence - even during a power outage. Peripheral electronic features can still be utilized in bypass mode as long as the appliance has power.

1. To activate the bypass valve for the main burners, locate the control module (mounted inside the grill cart enclosure), then push and rotate the dial to the ON position.

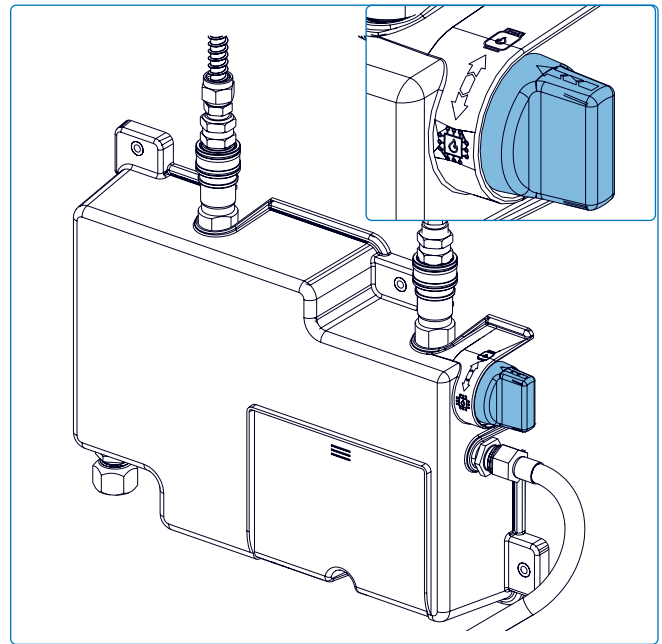

2. Follow the instructions in "**Lighting Your Grill**" section to ignite any desired burners.

## Smoker

Enhance your grilling experience with rich, wood-fired flavour using the integrated smoker system\*. When Smoke Mode is selected, the smoker box automatically activates and channels aromatic smoke into the main cooking enclosure for authentic barbecue-style results. This feature adds depth to meats, vegetables, and more. Perfect for low-and-slow cooking sessions.

The smoker should be started and emitting smoke before igniting any burners. Best performance is achieved with 1-2 burners on low. The gauge on the lid should always be in the smoke section.

### Ignition

1. Fill the smoker box – Add wood chips, or a mix of wood chips and chunks or pellets, until the box is almost full. Do not use charcoal. See **“Setting Up Your Smoker”** section for more details.
2. Select Smoke icon from the display screen. Follow the display prompt to ignite.



Following the ignition sequence, the wood chip ignition element will shut down and the blower fan will provide continuous smoke until the wood chip supply is depleted or 1 hour passes with no re-ignition sequence initiated.

Once ignition has been initiated, the fan cannot be turned OFF. This is an important safety feature designed to prevent uncontrolled burning inside the smoker. The smoker fan will automatically turn OFF after the cooldown cycle is complete (approximately 2 hours), or after 3 hours of inactive time.

### Re-Ignition

The re-ignition option is not available until 15 minutes after the conclusion of the ignition sequence. When the wood chip supply is depleted, but you want to extend the session:

1. Open the smoker door to access the wood chip tray. The access to smoker door is equipped with a safety switch to prevent heating element operation when the door is open.
2. Unlock the tool and engage with the front face of the wood chip tray. Unlock the tool and carefully slide the wood chip tray out for easy refilling without removing it from the appliance. See **“Tool Overview”** section.
3. Use metal tongs to redistribute spent wood chips, moving them to the front and back of the tray. Clearing a space on the metal mesh will aid in re-ignition of fresh wood chips. Do not remove any hot chips from the chamber. See **“Setting Up Your Smoker”** section.
4. Add a fresh layer of wood chips, ensuring good contact with the heat source for quicker ignition and steady smoke.
5. Use the tool to reinstall the wood chip tray. Close and latch the smoker door.
6. Hold the push button on the smoker unit for 2 seconds. The button will pulse red indicating that re-ignition stage is in progress (~4 minutes).

**NOTE:**

- The user must wait 15 minutes for the re-ignition option to become available again. This 15 minute timer is in place to prevent excessive heat cycling of the smoker.
  - Ignition and re-ignition can be cancelled at any time by selecting this option on the display, or depressing the push button for 5 seconds (as applicable to your model).
1. To achieve full shutdown of the smoker, you must leave it idle (no re-ignition) for 1 hour to start the full shutdown process (3 hours total). During the final 2 hours, the blower fan will remain in operation to prevent smoke back draft.
  2. After the smoker has completely cooled, empty the wood chip tray and dispose of the chip remnants in a fireproof container with a tight-fitting lid.

## Additional Control Functions

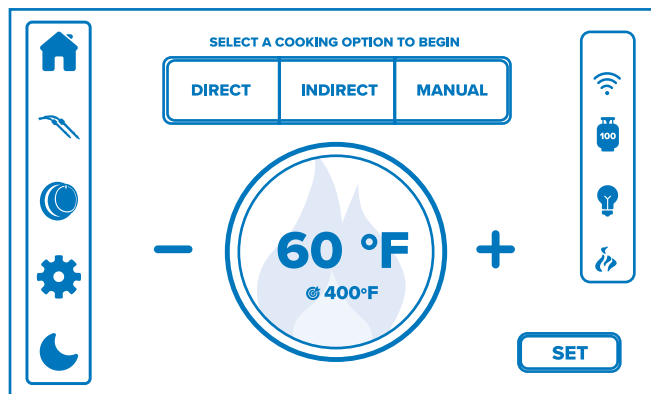

### Automatic Gas Shutoff

The grill automatically shuts off gas if temperatures exceed 850°F (454°C), preventing grease fires. When triggered, all burners stop, red lights flash, and a notification appears on the display and in the Napoleon Home App.



#### NOTE:

- The shut-off function is disabled while the system is in bypass mode.
- Safety red has been removed from all color selections and animations to prevent confusion with a lit burner.
- Scheduled shutdown occurs only after cooking or smoking ends, followed by a cleaning reminder and standard shutdown.

### Screen Lock/Unlock

For safety and to prevent accidental changes, the screen can automatically lock. To lock or unlock, press the moon icon on the display for 3 seconds. This renders the display unresponsive to other inputs.



#### IMPORTANT!

- The screen lock does not shut off the gas or lock the knobs.

Water droplets can impact touch sensitivity. It is recommended to lock the screen if using the grill in the rain.

### Proximity Detection

A built-in proximity sensor detects nearby motion and automatically wakes the display screen. This hands-free functionality ensures the display is only active when needed, conserving power while providing instant access to grill controls and status updates as you approach. Use the gear icon on the display screen to adjust how long the display stays active, anywhere from 15 to 60 minutes (5-minute increments).

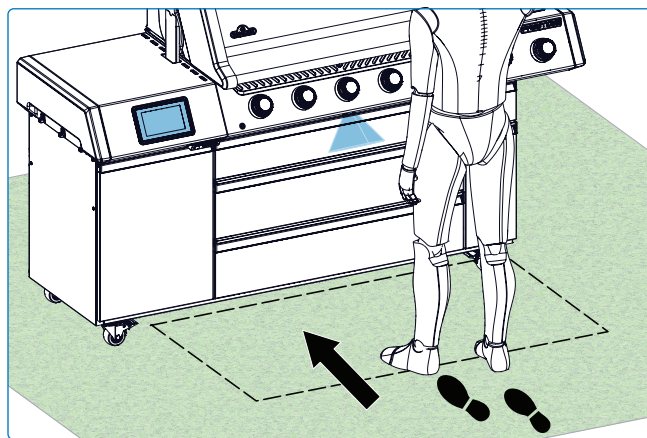

### Lighting and Animations

Vibrant control knob lighting animations add flair and personality to your grilling experience. Select the control knob icon on the display to choose from a variety of dynamic effects. Adjust brightness using the slider control.

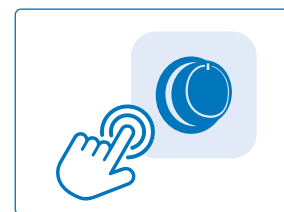

Activate storage lights through the lighting menu. Select ON to activate white storage lights. Select OFF to match the control knob lights' current colour. Select minimum brightness to turn the lights off entirely. Toggle cabinet and hood lights to ensure clear visibility.

### Responsive Control Knobs

As you adjust a burner setting, the interior portion of its control knob transitions through a smooth color gradient, visually indicating the burner's current setting. This intuitive feedback makes it easy to monitor flame intensity at a glance, even in low light. For added safety, the surround lighting features **SafetyGlow™** technology, glowing red whenever a burner is on to provide an instant visual cue.



### Food Temperature Probes

Connect up to two wireless probes (available separately) and up to three wired probes for precise and flexible temperature monitoring. After installing the probes, tap the probe icon on the display screen to select the type of food being cooked and set your desired target temperature. Once any probe reaches its set temperature, an alert tone will occur and a notification will be sent through the Napoleon Home App.

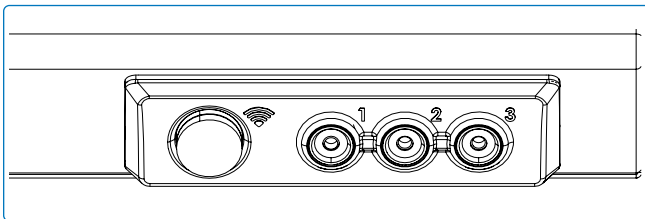
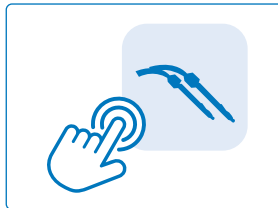

**NOTE:**

Wireless probe pairing is completed through on-screen prompts. Follow the display instructions to connect your probes easily.

### Tank Scale

Stay informed with the integrated tank scale, designed to accurately display the amount of propane remaining in your tank. Utilizing precision weight sensors, the system gives you real-time insight into fuel levels by reporting the current fill percentage. To ensure accurate readings, input your tank's empty and full weights using the Napoleon Home App during onboarding. For added convenience, the app also offers a regional tank selection feature, allowing you to quickly choose from a list of common tank types for easy setup.



## Lighting Your Grill

### Is it the very first time? Perform a Burn-off

Remove warming rack and run the main burners on high for 30 minutes. It is normal for the grill to emit an odor the first time it is lit. This odor is caused by the “burn-off” of internal paints and lubricants used in the manufacturing process and will not occur again.

#### **WARNING!**

- Do not operate the rear or side burner while performing a Burn-Off.

### Main Burner Lighting

1. Open grill lid.
2. Push and slowly turn any main burner knob counter clockwise to HIGH position until pilot lights. Continue to push down on the control knob until the burner lights and then release (**Fig. 6A & Fig. 7**).
3. If the pilot does not light – immediately turn the control knob clockwise to the OFF position. Repeat step 2.
4. If the pilot and burner will not light in 5 seconds – turn the control knob clockwise to the OFF position. Wait 5 minutes for gas to dissipate. Repeat steps 2 and 3, or light with a match.

### Rear Burner Lighting

1. Open grill lid.
2. Remove warming rack.
3. Push and slowly turn rear burner knob counter clockwise to HIGH position (**Fig. 6D & Fig. 7**).
4. Press and hold igniter button until the burner lights, or light by match (**Fig. 6C**).
5. If the burner will not light – turn burner control knob clockwise to the OFF position. Wait 5 minutes. Repeat step 3 and 4. (**Fig. 6**).

#### **WARNING!**

- Do not use the rear burner while operating the main burner.

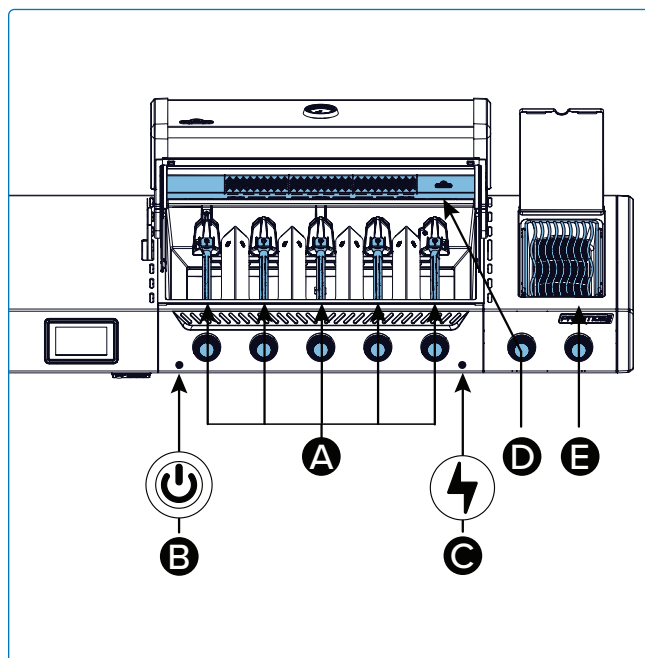

Fig. 6

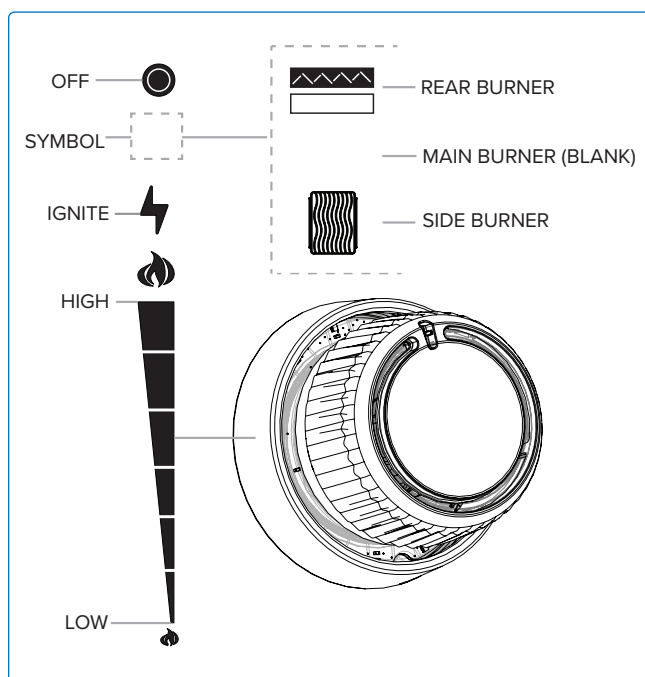

Fig. 7

### Side Burner Lighting

1. Open burner cover.
2. Push and slowly turn side burner knob counter clockwise to HIGH position.
3. Press and hold igniter button until the burner lights, or light by match.
4. If the burner will not ignite within 5 seconds – turn burner control knob clockwise to the OFF position. Wait 5 minutes. Repeat step 2 and 3. **(Fig. 6E & Fig. 7).**

### Alternative Ignition Instructions

1. Open the grill lid.
2. Light a long-reach match or butane lighter and position it close to the burner ports.
3. Turn the corresponding burner knob counter clockwise to the HIGH position until it lights **(Fig. 8).**

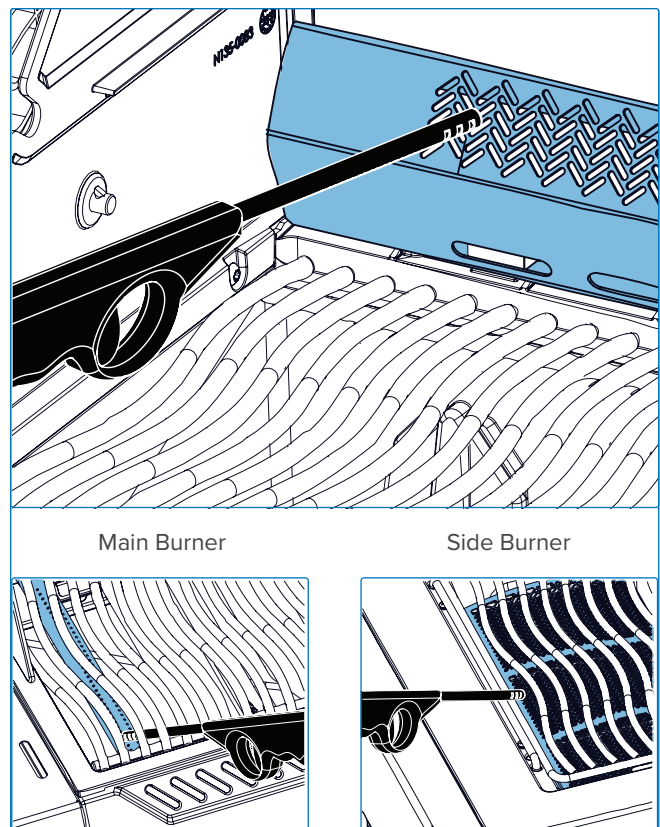
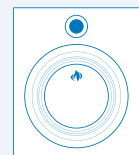

Fig. 8

### WARNING!

- Ensure all burner controls are in the OFF position before slowly turning on gas supply valve.
- Follow the lighting instructions carefully.
- Make sure the lid of the grill is OPEN while igniting.
- Do not adjust the cooking grids while the grill is hot, or operating.
- Regularly clean grease out of the entire unit, including the grease tray and the sear plates, to avoid build-up and grease fires.



## Monitoring Grill Temperatures

All models are equipped with two temperature indicators. A lid-mounted gauge indicates the air temperature within the cooking enclosure and is the preferred reference for the indirect cooking method.

A base-mounted sensor measures the temperature at the cooking grids and is the preferred reference for the direct cooking method. While optimized airflow throughout the cooking enclosure maximizes heating rates and temperature uniformity, several factors influence temperature readings, including:

### Food and Accessories Placement

- Large food items or cookware accessories, such as griddles and planchas, can trap heat over top of the cooking grid temperature sensor. This may lead to elevated sensor readings while also reducing lid temperature gauge readings as heat is directed elsewhere.

### Burners in Operation

- Temperature readings are affected by burner settings, as well as the base-mounted sensor's proximity to grill burners which are in operation.

### Time Elapsed

- The temperature indicators have different response times and may initially display varied readings as the appliance heats up. However, similar readings will be achieved once internal temperatures have stabilized.

For best results, utilize the temperature sensor feature along with the lid temperature gauge to fully compare the cooking environment against your target range. Allow time for temperatures to stabilize and adjust burner control settings accordingly.

## Infrared Main Burner Use (if equipped)

Follow the "**Main Burner Lighting**" Instructions and operate on high for 5 minutes with the lid closed or until the ceramic burners glow red.

Cook the food directly on the grid(s) following the directions on the "**Infrared Grilling Guide**". Food can be seared on the infrared burner and then transferred to the main burners of the grill to finish cooking over direct or indirect heat, depending on your taste and preference.

### Infrared Side Burner Use

Follow the "**Side Burner Lighting**" instructions and operate on high for 5 minutes or until the ceramic burner glows red.

Cook the food directly on the grid(s) following the directions on the "**Infrared Grilling Guide**". Food can be seared on the infrared burner and then transferred to the main burners of the grill to finish cooking over direct or indirect heat, depending on your taste and preference.

Do not close the side burner lid while the burner is operating or hot.



## DANGER!

- Regularly clean grease out of the entire unit, including the grease tray and the sear plates, to avoid build-up and grease fires.
- Do not deep fry food on the side burner. Cooking with oil can be dangerous.
- Do not close the side burner lid while the infrared burner is in use or still hot. Doing so may cause damage or pose a safety risk.

### Wind Guard

Keep your grill cooking smoothly in windy conditions up to 10 mph (16 km/h). Designed to attach easily to your grill, this guard acts like a shield against gusts of wind, helping to maintain consistent heat for evenly cooked meals.

Just adjust it to fit your grill, and you're ready to grill with confidence, no matter the weather. The guard can be folded and tucked away under the side burner lid for easy storage when the side burner is not in use.



**NOTE:**

The wind guard must be installed when using the side burner. This enhances safety and reduces cooking times.

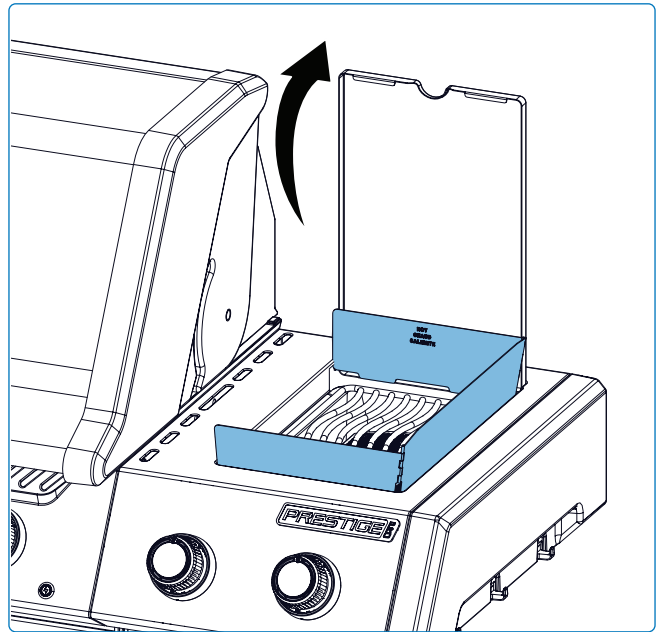
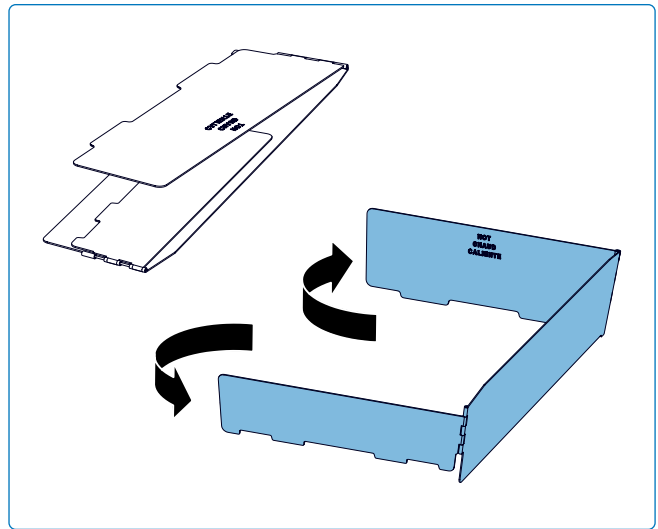

**GRILLING PRO TIP!**

Turn the grill perpendicular to the wind direction to minimize its effects.

## How to Use the Rotisserie

### Assembling Your Rotisserie Kit



#### NOTE:

- For the initial burn-off cycle, remove the warming rack completely. When using the rotisserie, the warming rack can be stowed in the upper position to allow clearance for the spit rod.
- Remove the rack only if necessary for additional space.
- Install the rotisserie motor on the side of the grill using the mounting bracket(s). Some models have pre-mounted brackets.

1. Once the bracket has been fastened to the grill, slide the rotisserie motor onto the bracket.
2. Slide the first rotisserie fork just past the middle of the spit rod and tighten into place. Thread the meat onto the spit rod and push the meat into the fork. Slide the second rotisserie fork on the opposite end of the spit rod and push the fork into the meat until secure. Tighten the fork into place.
3. Attach the counterbalance to the spit rod opposite the heavy side of the meat. Adjust until the load is balanced, then tighten securely.
4. Carefully insert the pointed end of the spit rod into the rotisserie motor and set the opposite end across the hangers. The heavy side of the meat will naturally hang down to balance the load.
5. Slide the stop bushing onto the spit rod until it is past the inside of the hood. This will secure the side to side movement of the spit rod.
6. Tighten the stop bushing and spit rod handle. Place a metal dish under the meat to collect the drippings.



#### IMPORTANT!

- Always wear protective gloves when handling components of the grill.

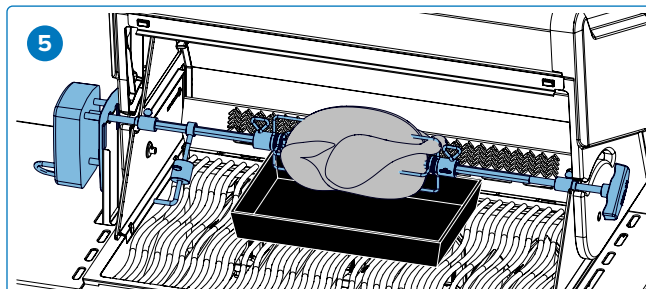
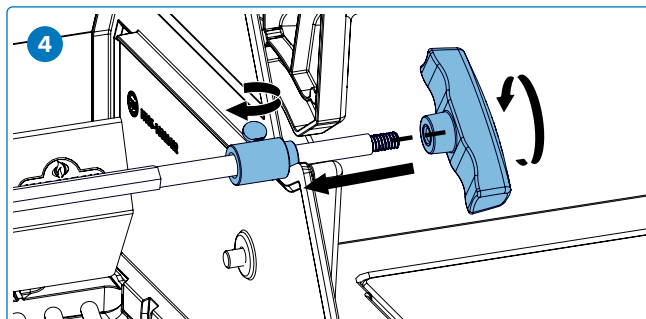
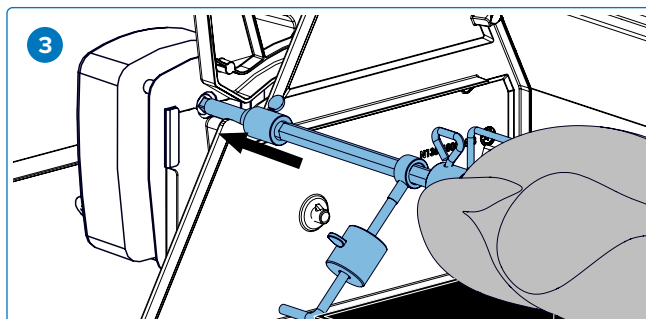
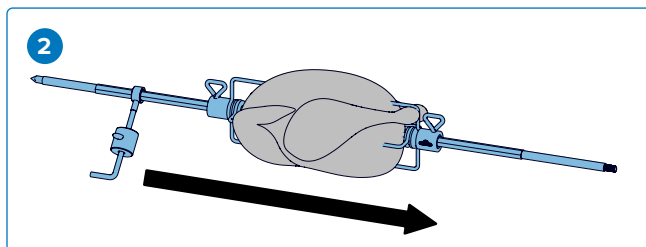
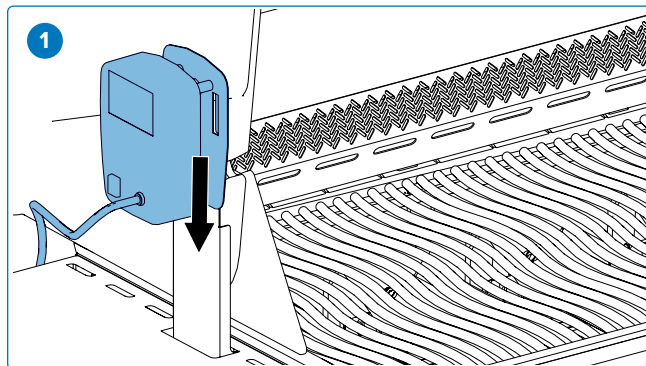

### Tips about using the Rotisserie:

- Operate the rear burner on high until the meat browns. Reduce heat. Keep lid closed.
- Use a thermometer to check the internal temperature of the meat.
- Roasts and poultry should brown on the outside and stay tender on the inside.
- Use drippings to baste and make gravy.
- A 3-pound chicken takes approximately 1 ½ hours on medium to high.
- Be mindful of your rotisserie motor capacity (15lb.). Never overload your equipment.
- Be sure to always set an evenly balanced load on your rotisserie.

### How to cook multiple chickens

Tie or skewer wings to the body of the chickens.

1. Slide rotisserie fork onto spit rod.
2. Thread first chicken onto spit rod until it is held into place by the rotisserie fork. Tighten.
3. Thread next 2 chickens onto spit rod so all the chickens are close together.
4. Slide second rotisserie fork onto spit rod and push into chicken until all 3 chickens are squeezed together tightly. Tighten.

### Storage

- Use the probe storage provisions on the side shelf when preparing to cook. Unplug the probes and bring them indoors when not in use to protect them from the elements (**Fig. 9**).
- Store the rotisserie components on the designated clips inside the cart cabinet and the spit rod on the back of the grill when not in use. This keeps them secure, protected from weather exposure, and easy to access for your next cook. Always ensure the parts are clean and dry before storing to prevent corrosion (**Fig. 10 & Fig.11**).

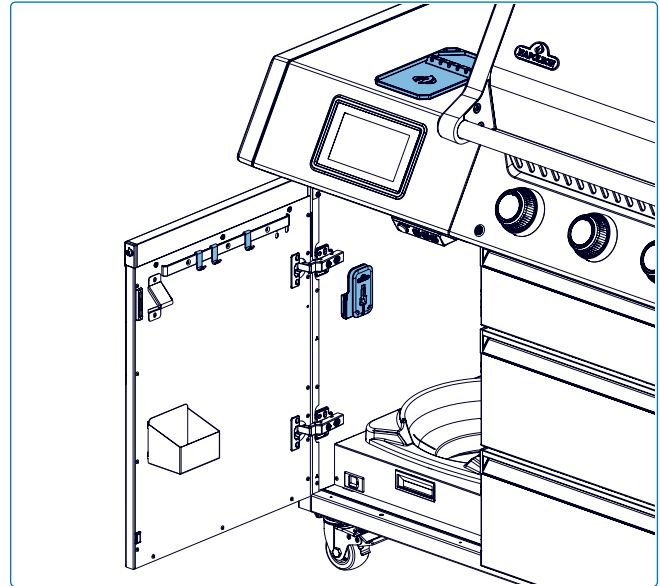

Fig. 9

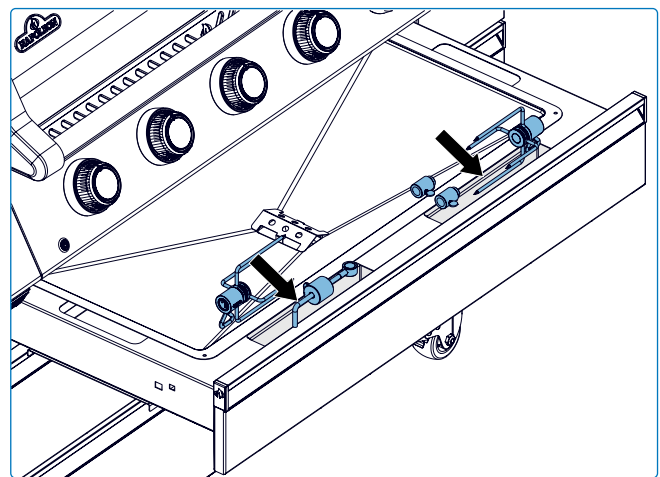

Fig.10

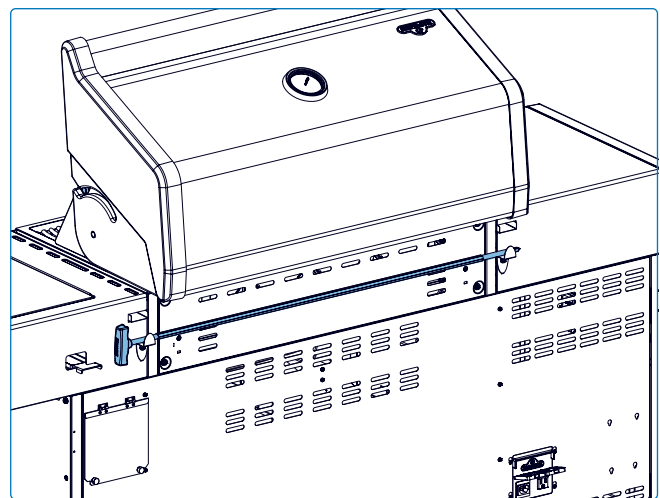

Fig.11

## The Grilling Experience Checklist

Refer to this list every time you grill

- Read Owner's Manual**  
Be sure to have read the owner's manual and all the safety instructions.
- Clean Grease Tray**  
Always ensure you clean the grease tray prior to grilling to avoid fires and flare-ups.
- Check the Hose**  
Ensure the grill is off and cool. Check the hose for evidence of excessive abrasions, or cuts. Have the hose replaced before use if the hose is damaged.
- Clean Grids and Preheat**  
Use a wood scraper or a natural fiber grill brush to clean cast iron and stainless steel grids. See "**Cleaning Instructions**". Coat the grids with vegetable shortening and preheat your grill to burn off excess residue and prevent sticking.
- Prep Area**  
Make sure everything you need while grilling such as your utensils, seasonings, sauces, and dishes are within your reach. Don't leave your food unattended, or it could burn.
- Flip once and do not Peek**  
Try not to open the lid and peek too much, or heat will escape and throw your temperature and cooking times off. Flip your food only once, especially steak and chicken.
- Leave Space**  
Leave some space on the grill and between food, so you have room to move food around if you need to.
- Use a Thermometer**  
Use a thermometer to ensure food is cooked thoroughly. Follow the appropriate temperatures guidelines for all types of meat, especially poultry.



### NOTE:

Stainless steel cooking grids are corrosion resistant and require less maintenance than cast iron grids.



### GRILLING PRO TIP!

Discover inspiring recipes and grilling techniques in Napoleon's cookbooks or visit [www.napoleon.com](http://www.napoleon.com)



### GRILLING PRO TIP!

Always preheat the grill before cooking to burn off leftover residue and prevent food from sticking to the grate.



### OIL AND FAT SUGGESTION!

- Grapeseed Oil,
- Sunflower Oil,
- Soybean Oil,
- Extra Virgin Olive Oil
- Canola Oil.

If not available, select an oil or fat that has a high smoke point.

Do not use salted fats like butter or margarine.

# ACCU-PROBE® Cook Assist

Confidently tend to the grill and your guests while using the integrated ACCU-PROBE® technology. Monitor internal grill temperature. Easily program your food type, target temperature, and cooking time using your smart device with the Napoleon Home App.

You will receive notifications on your device when your food is cooked to perfection. ACCU-PROBE® supports both Wi-Fi and Bluetooth® connectivity. If your default Wi-Fi is not available, the Bluetooth® function allows you to connect to ACCU-PROBE® with ease. The device must be initially provisioned using Wi-Fi. After provisioning, Bluetooth® will be available for connectivity, and Wi-Fi may still be used if supported.

See "Quick Start Instructions" and "Napoleon Home App" sections for more information on getting connected. Download the Napoleon Home App and enjoy smart cooking.

Any use of such marks and logos as indicated are owned by the respective owners and any such use by Wolf Steel Ltd. is under license: Bluetooth® by Bluetooth SIG, Inc. Other trademarks and trade names are those of the respective owners: Android™ and Google Play™ are trademarks of Google Inc.; Apple, iPhone®, and the Apple App Store is a trademark of Apple Inc.; iOS is a trademark or registered trademark of Cisco Inc.

## Compatible Devices

The Napoleon Home App is designed to work with a wide range of Android and iOS devices. Device compatibility is not guaranteed due to numerous different models and manufacturing standards.

## Display Overview

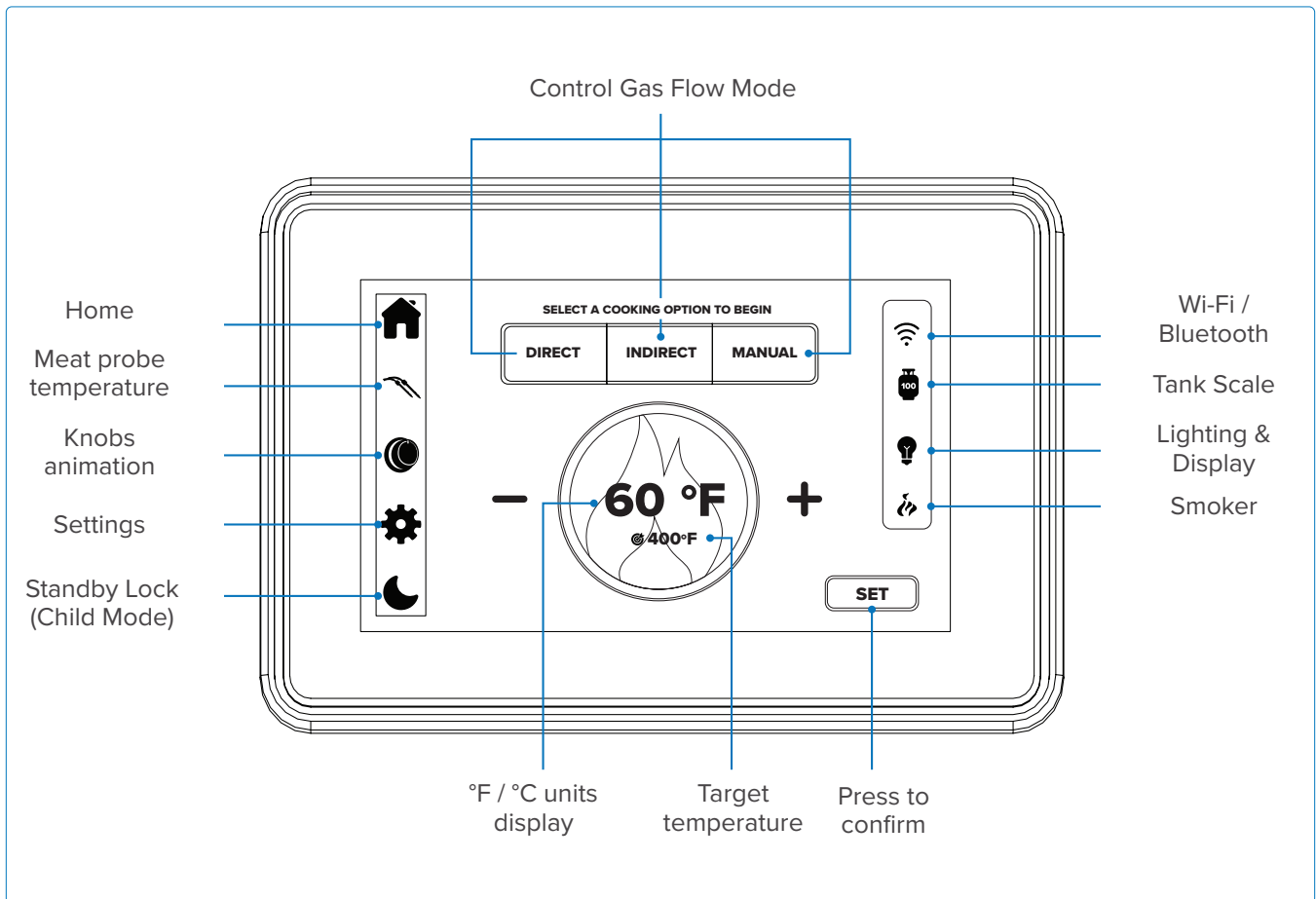

## Display Operation

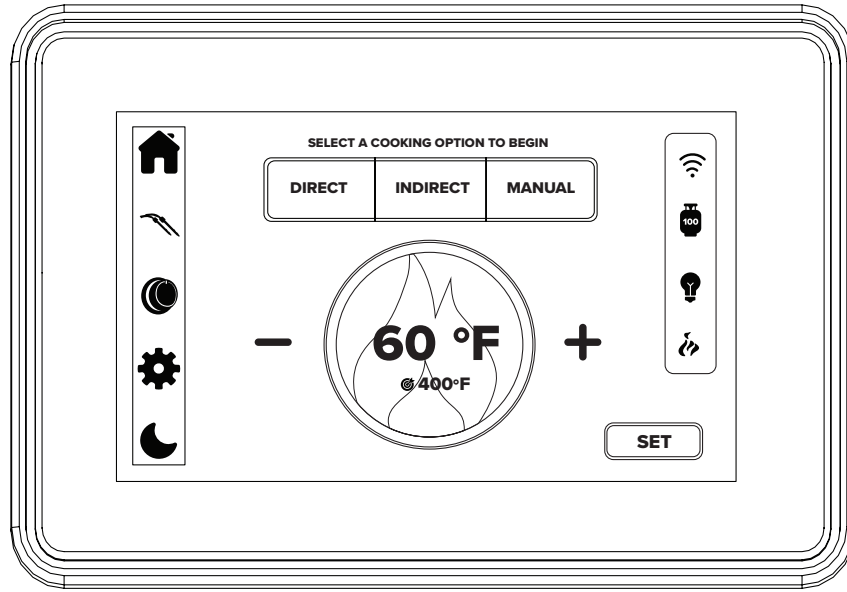

Function	Action	Duration	Description
Pairing Mode	Press and hold the power button for 10 seconds OR tap the Wi-Fi icon, then in the pop-up select Reset Network to make the system pairable.	10 seconds	<p>When the system restarts, the Napoleon logo will appear. The Wi-Fi and Bluetooth® icons will flash, indicating that the device is in pairing (Access Point) mode. You will need to provision the device again using the Napoleon Home App.</p> <p>This process should be completed when the display is active. If the display is off or in display timeout, continue to press and hold the button until Access Point Mode is reached. Alternatively, you can initiate pairing mode by tapping the Wi-Fi icon and selecting Reset Network from the pop-up menu.</p>
Wake-up Display	Single tap on the display or tap the moon icon	N/A	After awakening, the display will seamlessly return to its previous state. A tap on the moon icon will put the display screen into standby mode; tapping the same spot again will turn the screen back on.
Temperature Unit Change	Select the gear icon	N/A	Toggle between Celsius and Fahrenheit.

### How to Zero the Propane Tank Scale

1. Remove the empty propane tank.
2. Press the Zero button to initiate the tare process.
3. Wait 20 seconds for the scale to calibrate.
4. Place the new propane tank on the scale.

### Selecting a New Propane Tank

- Open the Napoleon Home App and go to the Tank Scale section (**Fig. 12**).
- Choose one of the following options:
  - » **North America:** Preselected default tank weights.
  - » **Europe:** Select from available tank specifications.
  - » **Custom Tank (Optional):** Enter the weight of an empty and full tank for accurate monitoring (**Fig. 13**).

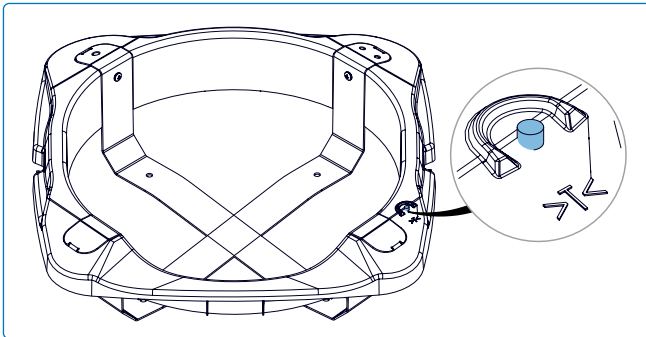

**NOTE:**

It may take about 1 minute to get the data updated to the app.

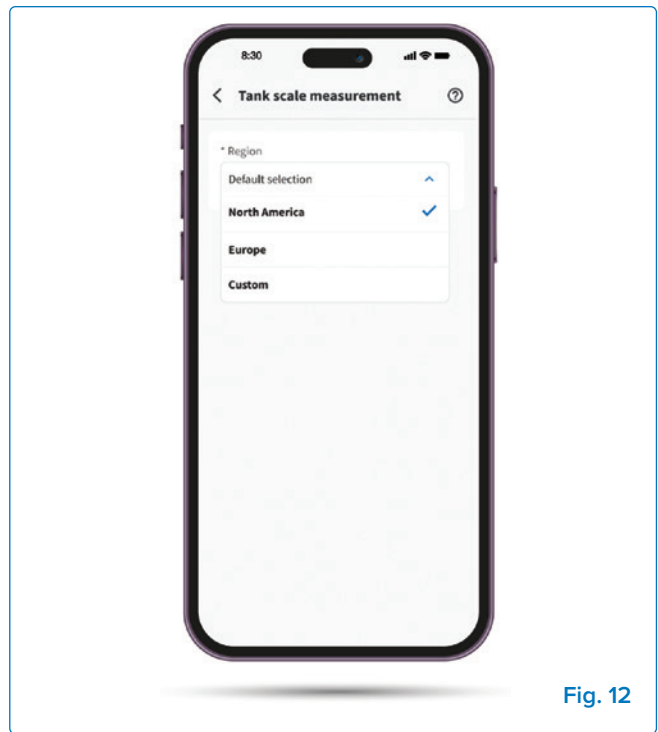

Fig. 12

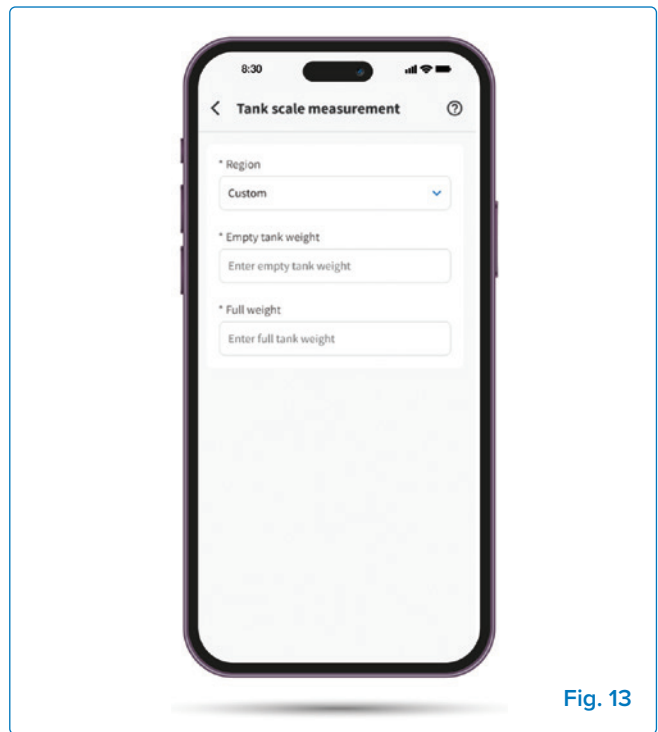

Fig. 13





## Safeguards





- Avoid high humidity or extreme temperatures.
- Avoid long exposure to direct sunlight or strong ultraviolet light.
- Do not disassemble or try to repair the unit on your own.
- Do not expose the unit or its accessories to flammable liquids, gases, or other explosives.
- Probes can operate from -4 ° F (-20 ° C) to 572 ° F (300 ° C).
- Probe cords can operate from -4 ° F (-20 ° C) to 716 ° F (380 ° C).
- **IMPORTANT:** Do not allow the probes to be directly exposed to flames or temperatures exceeding 572 ° F (300 ° C).
- For accurate readings, insert the probes into the center of meat, ideally before it is placed on the grill.
- **IMPORTANT:** Point the tips of the probes downward but do not allow the tips to touch the cooking grids. Also try to ensure that probes do not touch the body of the grill.
- Place meat on the side of the grill closest to the thermometer.
- Position the cord at a high exit point so the cord stays sufficiently above the cooking grids when the lid is closed.
- Alternatively, probe handles may be positioned under the lid seal. Ensure the sides of the grill do not exceed the highest probe operating temperature.
- When using more than one probe, colored probe rings can help identify the number of each probe. Place each ring around the probe tip and push until it reaches the base holder.

## Clearance

- Check that the cooking area does not exceed the maximum temperature and cords are not kinked or frayed by closed doors or lids.
- First check the cord clearance at ambient temperature with the lid closed. Examine the cord for any severe kinking or bending. Then turn the grill ON and check for hot spots where the cord may make surface contact.

# Infrared Grilling Guide

Food	Internal Temperature	Control Knob Setting	Cooking Time	Cooking Tips
 <p><b>Steak</b> 1 inch (2.54 cm) thick.</p>	Medium-Rare 54–60 °C (130–140 °F)	<b>HIGH</b> for 2 min each side, then <b>MEDIUM</b>	4–6 minutes each side, depending on thickness.	Ask for marbled fat in cut. Sear on high heat to lock in juices, then reduce heat for desired doneness. Let rest for 3 minutes before serving.
	Medium 60–66 °C (140–150 °F)			
	Well Done 77 °C (170 °F)			
 <p><b>Hamburger</b> ½ inch (1.27 cm) thick.</p>	Medium-Rare 54 °C (129 °F)	<b>HIGH</b> for 2–3 min each side	5–7 minutes total.	Shape patties to equal thickness for consistent cooking. Patties 1 inch thick or more should be grilled using indirect heat.
	Medium 60 °C (140°F)			
	Well Done 77 °C (170°F)			
 <p><b>Poultry</b></p>	74 °C (165 °F)	<b>HIGH</b> , then <b>LOW</b>	90 minutes total (depending on size)	Cut ¾ through the joint between the thigh and leg so the meat lies flat on the burner for even cooking.
 <p><b>Pork Chops</b></p>	64 °C (147 °F)	<b>MEDIUM</b>	6 minutes each side	Choose thick cuts for more tender meat. Trim off excess fat.
 <p><b>Fish</b></p>	70 °C (158 °F)	<b>MEDIUM</b>	5–10 minutes, depending on thickness	Cook until opaque and flakes easily.

Food	Internal Temperature	Control Knob Setting	Cooking Time	Cooking Tips
 <b>Shellfish/ Shrimp</b>	60°C - 65°C (140 °F - 149 °F)	HIGH	3–5 minutes	Discard any shellfish that don't open during cooking.
 <b>Spare Ribs</b>	74 °C (165 °F)	HIGH for 5 min, then LOW	25–30 minutes total	Grill until meat pulls easily from the bone.
 <b>Lamb Chops</b>	64 °C (147 °F)	HIGH for 5 min, then MEDIUM	10–15 minutes per side	Choose thick cuts for tenderness. Trim excess fat to prevent flare-ups.
 <b>Hot dogs</b>	74 °C (165 °F)	MEDIUM to LOW	5–7 minutes total	Grill or boil until heated through.

# Smoker Guide

## Quick Smoking Tips

To help you get the most out of your smoker, we've created this quick-reference guide filled with practical tips for better results. These proven techniques enhance flavor, improve smoke adhesion, and help you achieve more consistent cooks—so you get the best flavor every time and make the most of your cooking experience.



### Start With Smoke

Start the smoker ahead of time and wait for it to produce clean smoke before placing any food on the grill or igniting the burners.



### Cold Meat = Better Smoke Ring

Place meat straight from the fridge into the smoker. The cooler surface absorbs more smoke early on.



### Keep It Moist

Mist the meat with a spray bottle every 45–60 minutes. Don't overdo it—just enough to keep the surface tacky, not soaked.



### Use a Water Tray

A water pan maintains humidity. Moist air helps smoke cling better and keeps meat juicy.



### Rough = More Smoke Flavor

Score the surface or apply a coarse rub (e.g., cracked pepper, herbs). Creating a rough texture—through scoring or seasoning—enhances smoke absorption. The increased surface area and irregularities help trap smoke particles more effectively, resulting in a deeper, richer, and more complex smoky flavor.



### Avoid White Billowy Smoke

Thick white smoke means incomplete combustion. Use quality wood chips, or chunks for cleaner burning.



### Temperature Zones Matter

Understand your BBQ's hot and cool zones. Rotate meat as needed to cook evenly and avoid dry spots.





### Patience Pays Off





Don't rush. Keep the lid closed—every peek adds 10–15 minutes to the cook time. Trust the process!





## SMOKING PRO TIPS!

- Let meat rest after smoking to allow juices to redistribute. It can make a big difference in tenderness and flavor.
- If not cleaned, your smoker can build up creosote—a tar-like residue that gives food a bitter, unpleasant taste.
- Use a meat thermometer for accuracy. Don't rely on time alone—internal temperature is key.
- Practice makes perfect. Every cut of meat behaves differently. Stay patient and keep experimenting.

Food Type	Wood Type(s)	Smoke Temp °C (°F)	Smoke Time	Cooking Tips	
 <b>Beef</b>	<b>Brisket</b>	Hickory, Oak, Mesquite	107–116 °C (225–240 °F)	6–8 h (until wrapped, at 74 °C / ~165 °F)	<b>Cook Time:</b> 12–18 h total. Use water pan for moisture; wrap in foil after the stall.
	<b>Short Ribs</b>		107–116 °C (225–240 °F)	3–4 h (until wrapped)	<b>Cook Time:</b> 6–8 h total. Keep bone side down; rest 1 h after cooking.
	<b>Meatloaf</b>	Hickory, Oak, Applewood, Pecan	107–135 °C (225–275 °F)	2.5 - 3.5 h	Let the meatloaf rest for 10–15 minutes before slicing to retain moisture.
 <b>Pork</b>	<b>Boston Butt</b>	Apple, Cherry, Pecan		12–14 h	Smoke to 90–95 °C (195–203 °F) for shredding.
	<b>Baby Back Ribs</b>	Apple, Cherry, Hickory	107–116 °C (225–240 °F)	~5 h (3-2-1 method)	Wrap in foil at hour 3; finish unwrapped for bark
	<b>Spare Ribs</b>			~6 h	Spritz with apple juice every hour for moisture.
	<b>Tenderloin</b>	Apple, Cherry, Oak		~2–4 h	Don't overcook — remove at 63 °C (145 °F)
 <b>Chicken</b>	<b>Whole</b>	Apple, Cherry, Maple	121–135 °C (250–275 °F)	3–4 h	Tie legs and tuck wings; smoke to 74 °C (165 °F)
	<b>Legs/Thighs</b>	Apple, Maple, Pecan	121–135 °C (250–275 °F)	~2 h	Higher temps crisp the skin; no need to flip
	<b>Wings</b>	Apple, Cherry, Maple	121–135 °C (250–275 °F)	1.5–2 h	Toss in oil/spices before smoking; finish over direct heat for crispiness.
	<b>Breast</b>	Apple, Cherry, Maple	107 °C (225 °F)	~1 h	Use meat thermometer, remove at 71 °C (160 °F), rest to 165 °F.

Food Type		Wood Type(s)	Smoke Temp °C (°F)	Smoke Time	Cooking Tips
 <b>Turkey</b>	<b>Whole</b>	Apple, Cherry, Pecan	116 °C (240 °F)	5–7 h	Use water pan; spatchcock for even cooking.
	<b>Breast</b>			~ 4 h	Baste every hour for moistness.
 <b>Venison</b>	<b>Tenderloin</b>	Oak, Cherry, Hickory	107 °C (225 °F)	~45 min/lb	Mild wood preserves game flavor; don't over smoke.
 <b>Game Birds</b>	<b>Duck – Whole</b>	Apple, Cherry, Pecan	121–135 °C (250–275 °F)	3–4 h	Score skin for fat rendering; finish at high heat to crisp skin.
	<b>Duck – Breast</b>	Apple, Maple, Alder	107 °C (225 °F)	~ 1.5 h	Smoke skin-side up; pull at 135–140 °F / 57–60 °C for medium rare.
	<b>Quail</b>	Applewood, Cherry, Pecan	107 °C (225 °F)	1–1.5 h	Lightly mist with apple juice or broth during smoking to maintain moisture and enhance smoke adhesion.
 <b>Seafood</b>	<b>Salmon – Fillet</b>	Alder, Cherry, Maple	104 °C (220 °F)	1 h	Salmon can be cold smoked by curing it with salt and exposing it to smoke at 68–86°F (30 °C–20 °F) without cooking. Use skin-on fillets; finish with lemon glaze.
	<b>Trout – Whole</b>	Alder, Oak, Cherry	107 °C (225 °F)	1 h	Stuff cavity with lemon/herbs; smoke in a basket
	<b>Lobster Tails</b>	Alder, Apple, Cherry		~ 45 min	Split tails for better smoke penetration.

Food Type	Wood Type(s)	Smoke Temp °C (°F)	Smoke Time	Cooking Tips
 <b>Vegetables</b>	<b>Bell Peppers</b>	Apple, Cherry		1.5–2 h Slice in halves or thick strips; oil lightly.
	<b>Potatoes – Whole</b>	Apple, Cherry, Pecan	107–116 °C (225–240 °F)	2–3 h Poke holes and rub with oil/salt; wrap in foil for soft skin.
	<b>Carrots</b>			1.5–2 h Smoke with a touch of honey or brown sugar for sweetness.
	<b>Tomatoes (Romas)</b>	Cherry, Apple	93–107 °C (200–255 °F)	1.5–2 h Cut in half; ideal for sauces or salsa.
 <b>Cheese</b>	<b>Cheddar (Aged)</b>	Apple, Cherry, Maple	32 °C (90 °F)  <b>Note:</b> Cold days make it easier to keep smoker temps low—ideal for cold smoking cheese without melting it.	1.5–2 h Let sit unwrapped in fridge for 24–48 h after smoking to mellow
	<b>Gouda</b>	Apple, Pecan		Slice into small blocks or smoke whole; let rest 48 h.
	<b>Mozzarella (Low Moisture)</b>	Apple, Cherry		~ 1 h Use firm blocks; smoke gently or it may melt.
	<b>Swiss / Jarlsberg</b>	Apple, Alder		2 h Chill before smoking; let rest 2 days for full flavor
	<b>Cream Cheese (Block)</b>	Apple, Maple		1–2 h Score top in crosshatch; season or coat with rub before smoking.
	<b>Brie</b>			~ 1 h Freeze briefly before smoking to help it hold shape.
	<b>Halloumi (Cold-Smoked)</b>			1–1.5 h Slice ¼–¾" thick; use indirect setup with ice pan; rest 24–48 h
<b>Halloumi (Hot-Smoked)</b>	Apple, Cherry, Pecan	107 °C (255 °F)	30–45 min Leave whole or thick-sliced; firm texture holds well; serve warm or seared.	

# Operation

## Door

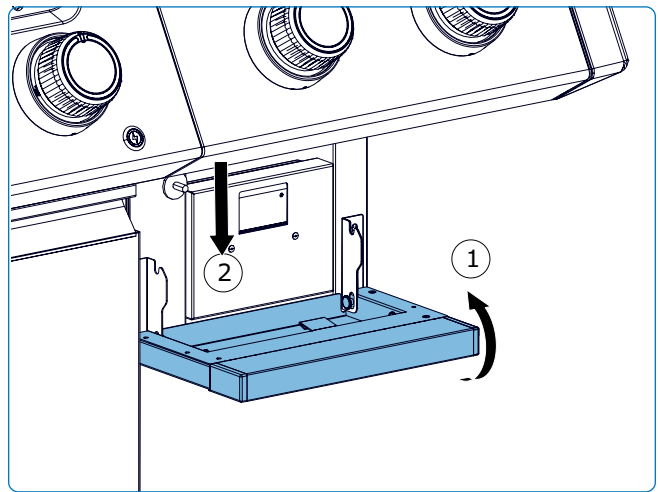
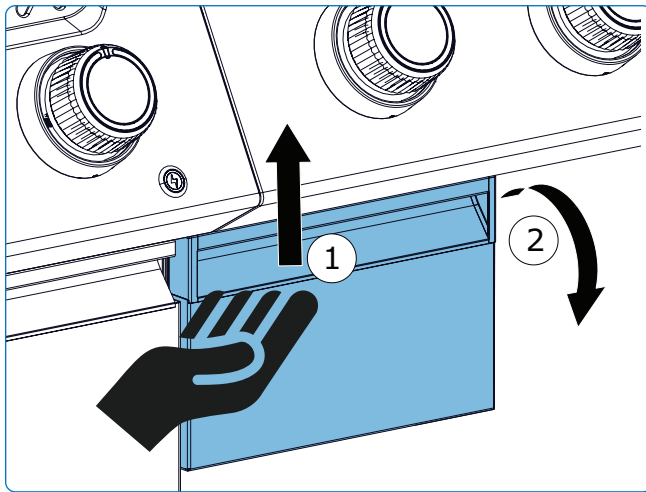

## Tool Overview

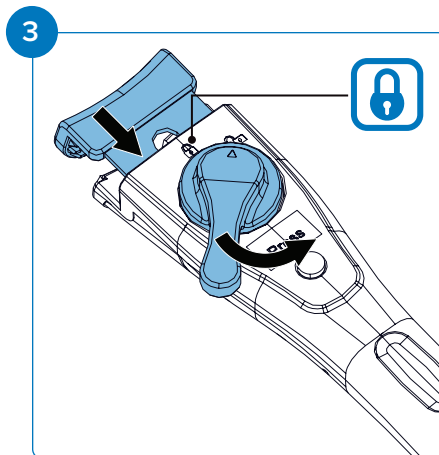
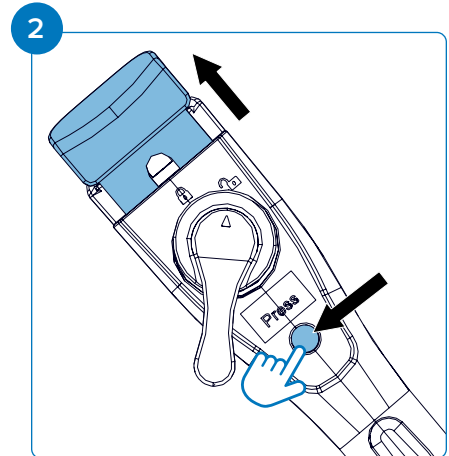
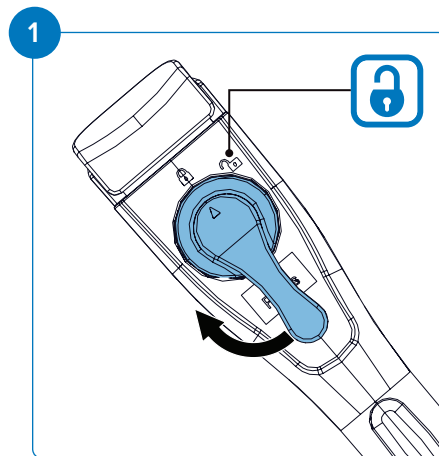
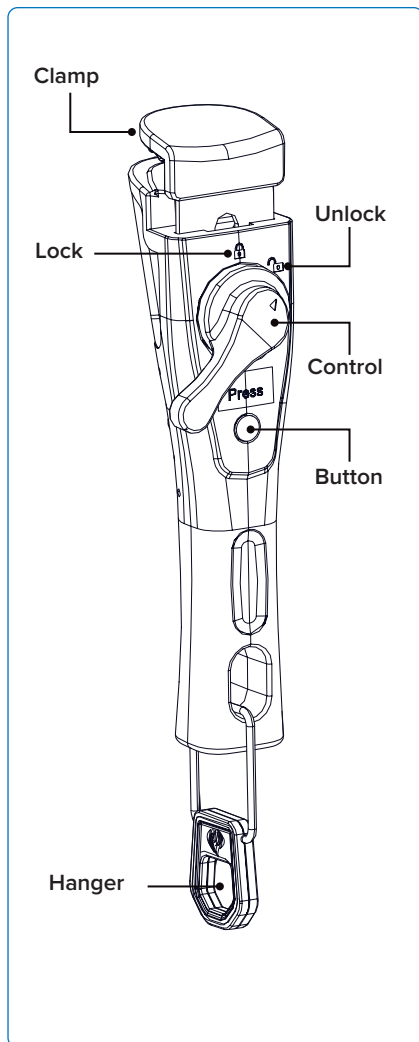

## Wood tray

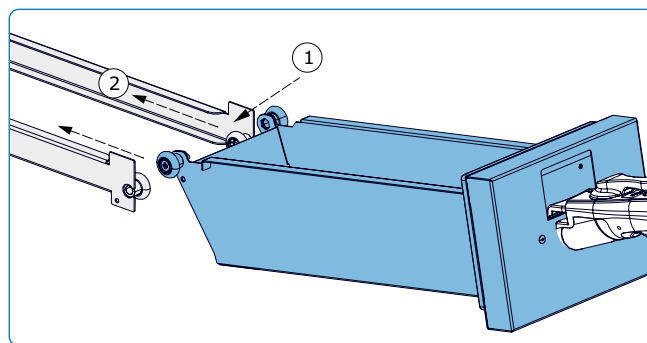
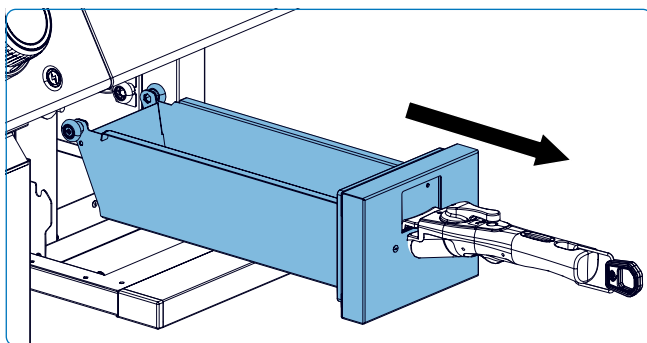
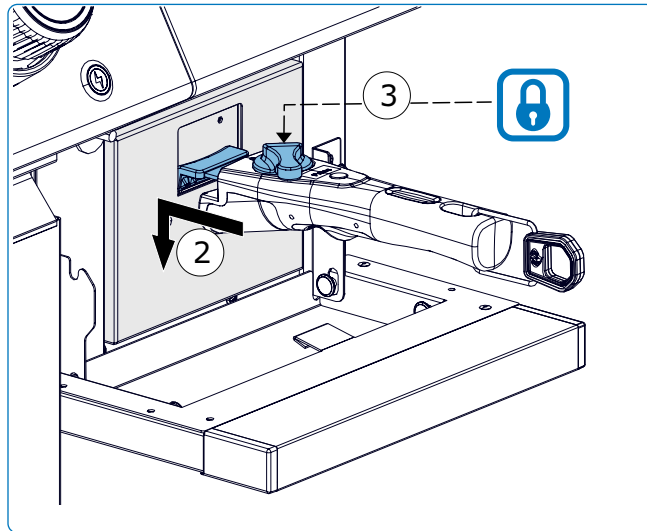
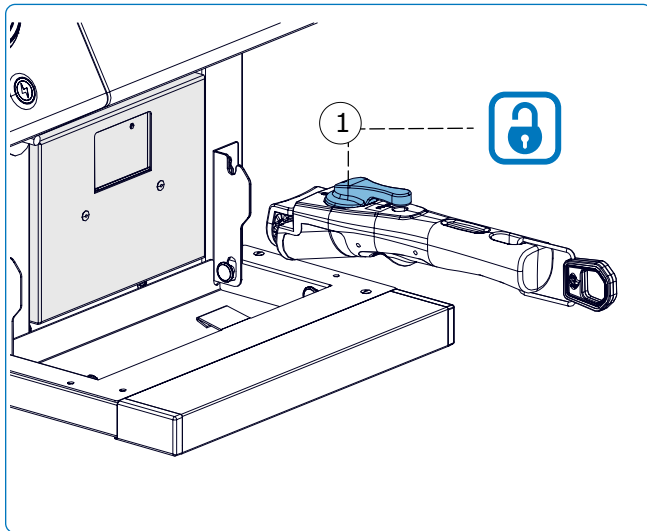

## Setting Up Your Smoker

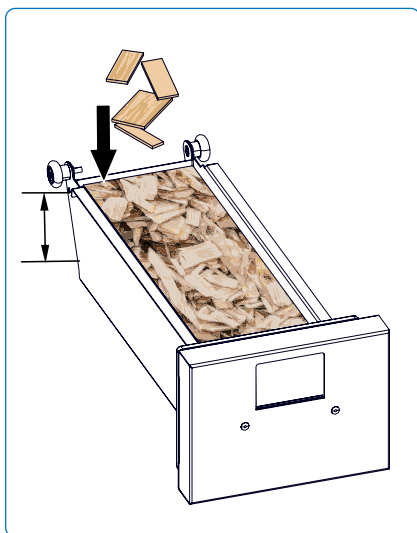

- Fill with woodchips up to the top of the tray. Approximately 480 g. or 6 cups.

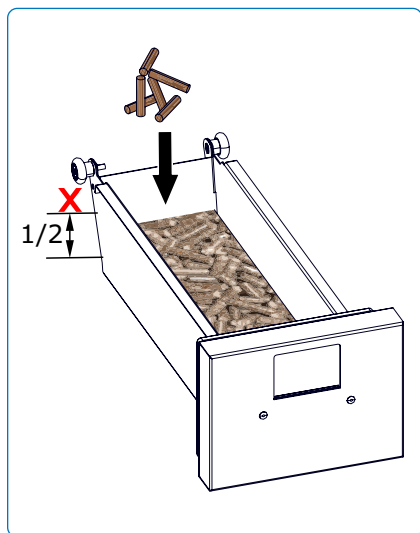

- Fill with wood chips no more than half way. Approximately 180 g. or 2 cups.

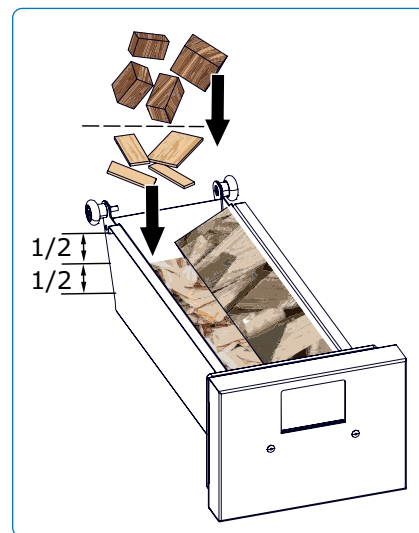

- Layer with wood chips no more than half way. Place wood chunks on top of wood chips.

# Cleaning Instructions

## Cleaning the Smoker Box

To keep your smoker box in top condition and ensure the best smoky flavor for your grilled food, follow these simple cleaning steps after each use:

1. **Cool Down Completely** – Let the smoker box and grill cool before handling to prevent burns and ease ash removal. Ash and creosote can accumulate inside, especially near the heating element.
2. **Unplug Before Cleaning** – Always unplug the smoker box before cleaning near the heating element for safety.
3. **Empty the Ashes** – Remove the wood tray from the grill and dump out any remaining wood chips or ash into a metal container.
4. **Remove and Clean the Mesh** – Take out the mesh that holds the wood chips. Shake off any remaining debris and brush it clean (**Fig. 14**).
5. **The smoker outlet pipe** – can be unscrewed for cleaning—insert a screwdriver into the tip holes for extra leverage (**Fig. 15&16**).
6. **Scrape Off Residue** – Use a grill brush or metal scraper to remove charred wood bits or stuck-on debris from the interior surfaces, inner shell, and wood chip tray.
7. **Wipe Down the Smoker Box** – Clean inside and outside surfaces with a 50/50 mix of warm water and apple cider vinegar using a sponge. This cuts through creosote. Use a metal brush or abrasive pad for stubborn buildup. Avoid excess moisture near electrical parts (**Fig. 17**).
8. **Reassemble and Store** – Once dry, return the wood tray to the grill.

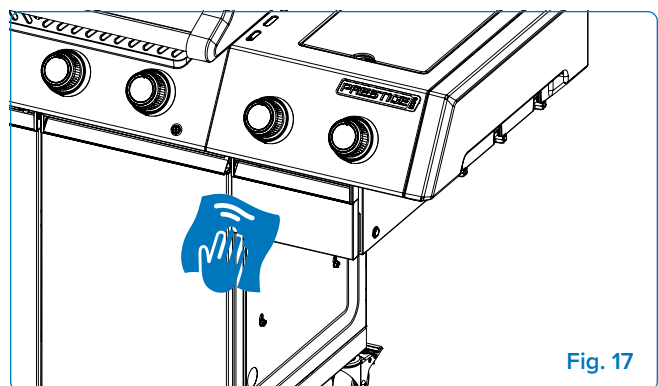
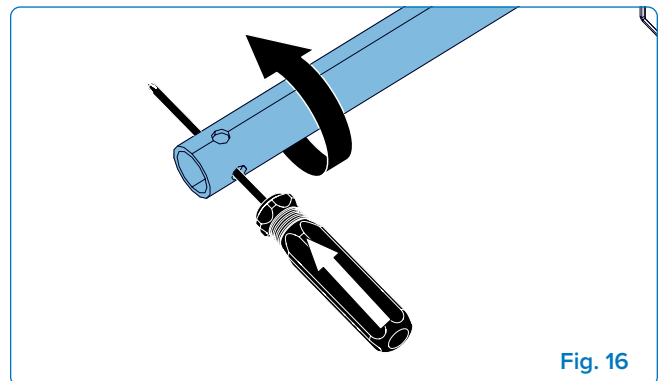
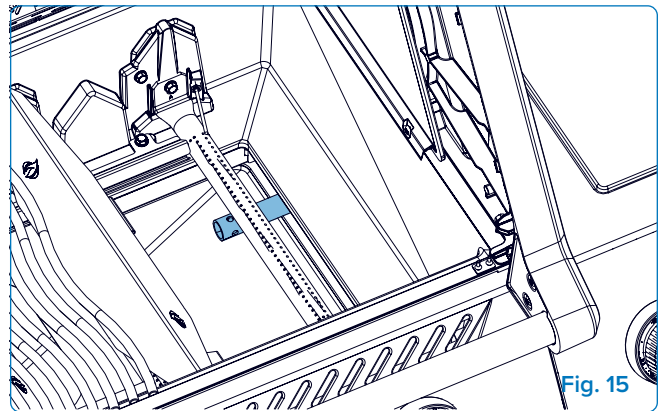
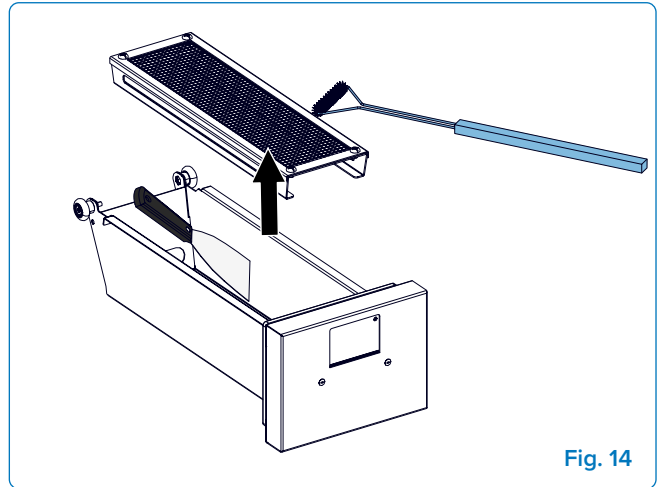

### PRO TIP!

Regular cleaning preserves flavor and extends smoker life!

## Cleaning your Grill for First Time Use

1. Wash grids by hand with water and mild dish soap to remove any residue from the manufacturing process. **DO NOT** wash in a dishwasher.
2. Rinse thoroughly with hot water and dry completely with a soft cloth to prevent moisture from entering.

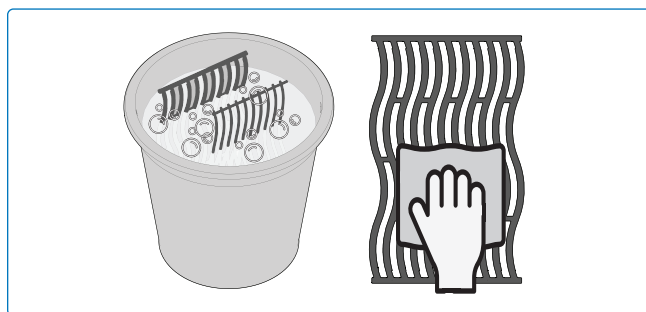

## Stainless Steel Grids

- Stainless steel cooking grids can be cleaned by preheating the grill and using a wire brush to remove residue.
- Stainless steel grids will permanently discolor from regular use because of high temperatures when grilling.

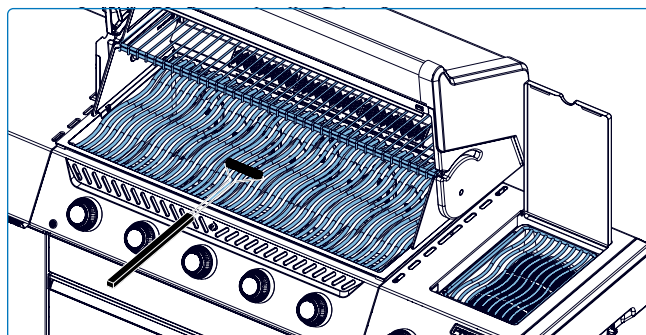

## Infrared Side Burner

- Most drippings and food particles that fall on the infrared burner surface incinerates immediately because of the high intensity heat.
- Do not clean the ceramic tile with a wire brush.
- Do not use water or other liquids to clean the burner. An immediate change in temperature will cause cracking of the ceramic tile.
- Light burner and operate on high for 5-10 minutes to remove any left-over residue.

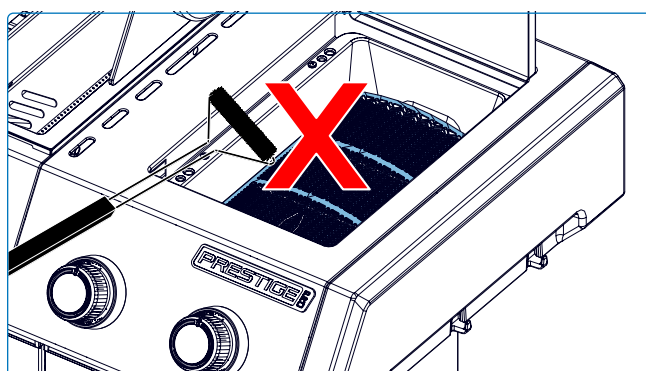

### NOTE:

To clean the stainless steel mesh cover on the side burner, use a soft-bristle brush.. Do not use the brush on the ceramic tiles.

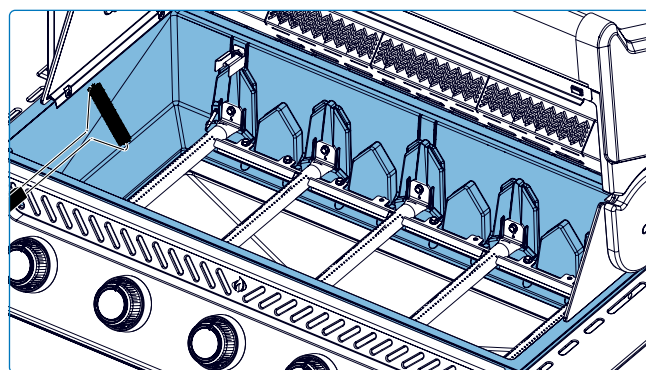

## DANGER!

- Always wear protective gloves and safety glasses when cleaning your grill.
- Cleaning should only be done when the grill is cool to avoid the possibility of burns.
- Accumulated grease is a fire hazard.

## Inside of the Grill

1. Remove the cooking grids.
2. Brush debris from the lid and sides with a brass wire brush.
3. Scrape sear plates with a putty knife, then brush off ash.
4. Remove sear plates and clean burners with a wire brush.
5. Sweep debris into the drip pan.



### NOTE:

This model includes bottom sear plates located just above the grease tray for optimal heat distribution.

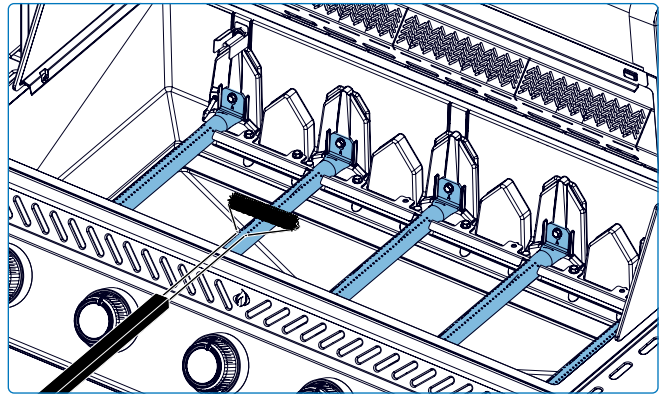
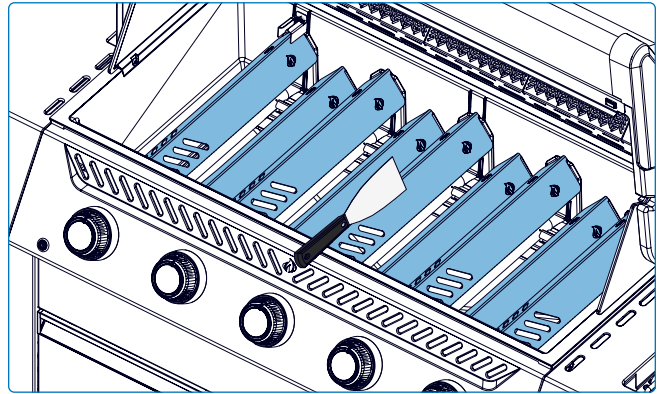

## Drip Pan

Every grill head, side burner and drop-in burner has a corresponding drip pan. It is easily accessible through doors or openings.

- Grease and excess drippings collect in the drip pan located beneath the grill and accumulate in the disposable grease tray below the drip pan (if applicable).
- Only use Napoleon approved liners on the drip pan. Never use aluminum foil, sand or any other unapproved material. This can prevent grease from flowing properly.
- Clean frequently to avoid grease build-up – approximately every 4-5 uses.

### Cleaning steps:

1. Slide the drip pan from the grill to access the disposable grease tray or to clean the drip pan.
2. Scrape the drip pan using a hard plastic scraper to prevent scratches that could lead to rust.
3. Replace the disposable grease tray every 2–4 weeks depending on grill usage (if applicable).
4. See your Napoleon Grill dealer for supplies.

## Thermocouples

Flame sensor and two thermocouples are located near the main burners (**Fig.18**). In case of grease buildup, gently wipe the metal tips with a soft cloth or use fine-grit sandpaper if needed. Avoid using water, harsh chemicals, or applying pressure, as these components are delicate and can be easily damaged by forceful cleaning. Make sure all parts are dry before reassembly.

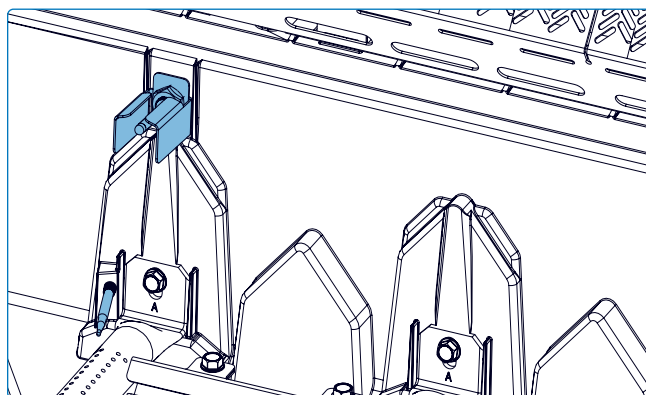
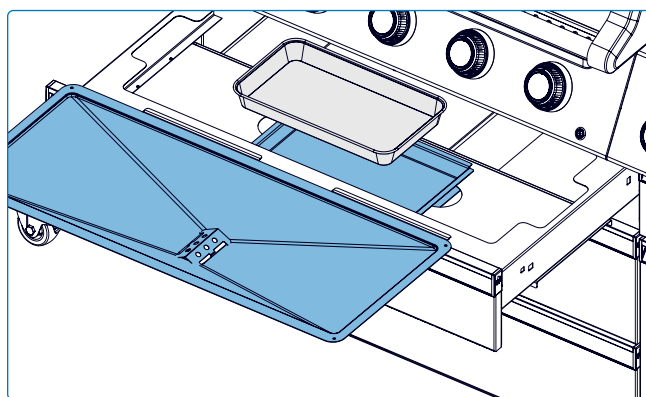
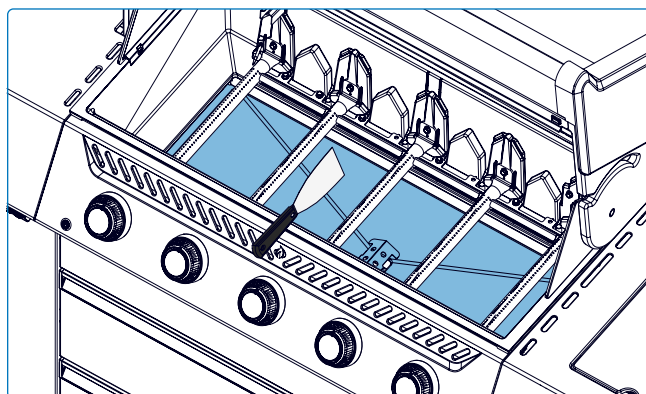
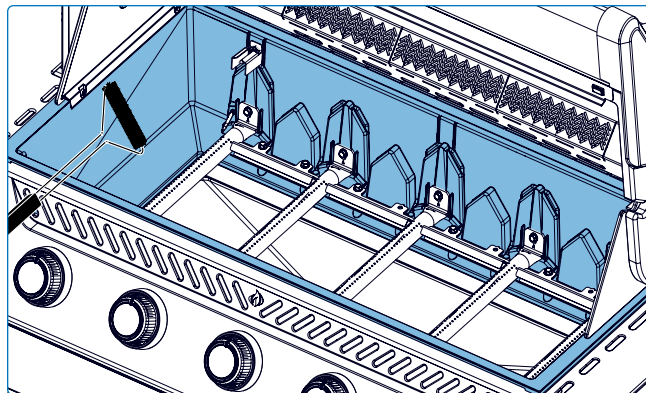

Fig. 18

## Control Panel

ONLY use warm soapy water. Text is printed directly printed on the bezels. Proper cleaning will ensure the text remains dark and legible. Avoid abrasive or stainless steel cleaners, as they can damage the finish and printed text.

## Aluminum Castings

Clean with warm soapy water. Aluminum doesn't rust, but high temperatures and weathering can cause oxidization on the surface of the castings that look like white spots.

See “**Maintenance Instructions**” for more information on how to prevent oxidized aluminum.

## Outside Grill Surface

- Only use a non-abrasive cleaner. Abrasive cleaners or steel wool will scratch the finish.
- Always wipe in the direction of the grain.
- Handle porcelain enamel components with care.
- The baked-on enamel finish is glass-like and will chip if struck.

Stainless steel parts discolor overtime when heated and will turn a golden or brown hue. This is normal and won't affect the performance of the grill.

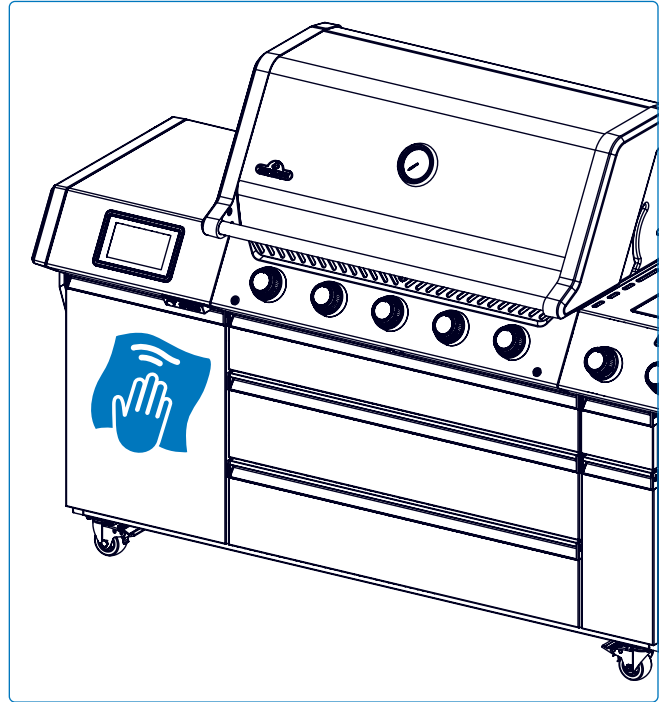

## WARNING!

- Ensure all burners are turned off, the gas bottle is closed, and the grill is cool before cleaning. Do not use oven cleaner on any part of the grill.
- Do not put cooking grids or any other parts of the grill in a self-cleaning oven to clean. Clean the grill in an area where cleaning solution won't harm decks, lawns, or patios.
- Barbecue sauce and salt can be corrosive and will cause rapid deterioration of the grill components unless cleaned regularly.

## Insect Screen and Burner Ports

Spiders and insects are attracted to small enclosed spaces. Napoleon has equipped the burner with an insect screen on the air shutter.

This reduces the likelihood of insects building nests inside the burner, but doesn't eliminate the problem.

A nest or web can cause the burner flame to burn a soft yellow or orange and cause a fire or flashback at the air shutter underneath the control panel.

1. Remove the screw (s) that attaches the burner to the back wall of the grill. Slide the burner back and upwards to remove. **(Fig.19).**
2. Clean the inside of the burner using a flexible venturi tube brush or, for delicate areas, a soft bristled brush to gently remove debris.
3. Shake loose debris from the burner through the gas inlet.
4. Check the burner ports and valve orifices for blockages: burner ports can close over time because of cooking debris and corrosion.
5. Use an open paper clip or drill bit to clean the burner ports. While this can be done with the burner attached, it is easier if removed from the grill.
6. Do not flex the drill bit when drilling the ports because the drill bit will break.
7. This drill bit is for burner ports NOT for brass orifices that regulate the gas flow to the burner.
8. Do not enlarge the holes.
9. Ensure the insect screen is clean, tight, and free of any lint or other debris.
10. Reverse the procedure to reinstall the burner.
11. Ensure the valve enters the burner when installing.
12. Replace sear plate mount and tighten screws to complete re-installation.

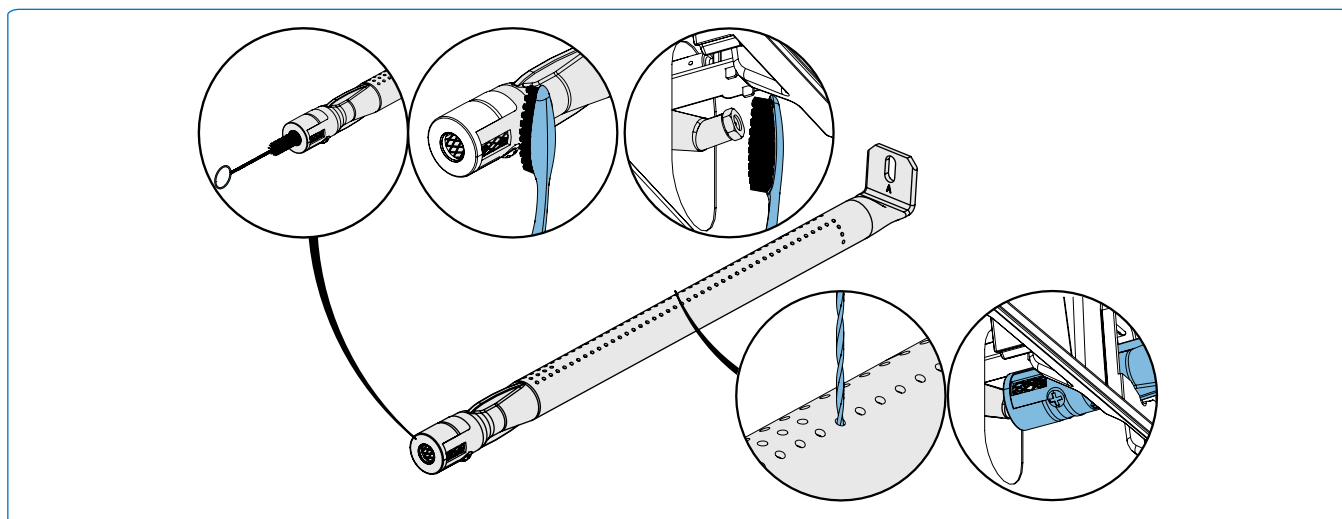

Fig. 19



### DANGER!

- It is very important the valve/orifice enters the burner tube when reinstalling the burner after cleaning and before lighting your grill, or a fire or explosion could occur.
- Avoid unprotected contact with hot surfaces.
- Do not use abrasive cleaners or steel wool on any painted, porcelain, or stainless steel parts of your grill because it will scratch the finish.



### SAFETY FIRST!

Always wear protective gloves and safety glasses when servicing your grill.

## Temperature Probes

- Clean the probes before using for the first time.
- Hand wash the metal portion of probes and dry thoroughly after each use. Do not wash in a dishwasher.
- Probes are rust-proof and corrosion resistant. Do not use any chemicals or cleaning solutions to clean the probes except mild soap.



### NOTE:

The probe jacks, probe cables, and display unit are water resistant but should not be left in the rain. The appliance should never be immersed in water.



### WARNING!

- Keep the grill away from combustible materials, gasoline, and other flammable vapors and liquids.



### WE WANT TO HELP!

Contact your authorized dealer for recommended replacement parts.

# Maintenance Instructions

## General Requirements

This grill should be thoroughly inspected and serviced annually by a qualified service person.

- Do not obstruct the flow of ventilation and combustion air.
- Keep the cylinder enclosure ventilation openings located on the side of the cart or enclosure and front and back of the bottom shelf clear from debris.

## Combustion Air Adjustment



### IMPORTANT!

- This must be done by a qualified gas installer.

- The air shutter is factory set and should not require adjusting under normal conditions. Adjustments might be required under extreme field conditions.
- The flames of the air shutter will be dark blue, tipped with light blue and occasionally yellow when adjusted correctly.
- Too little air flow to the burner will produce soot and lazy yellow flames.
- Too much air flow to the burner will cause flames to lift erratically and cause igniting difficulties.

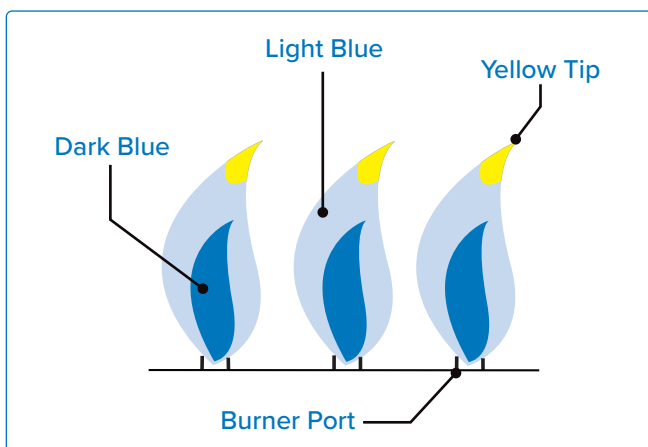

## Adjusting the Air Shutter

1. Remove cooking grids and sear plates. Leave lid open.
2. You must remove the burner to access and adjust the air shutter screw, as it is not otherwise accessible.
3. Remove the back cover to adjust rear tube burner air shutter.
4. Loosen air shutter lock screw and open or close air shutter as required.
5. Light the burners on high.
6. Visually inspect burner flames.
7. Turn burners off, tighten locking screws, and replace removed parts when shutters are set correctly.
8. Ensure insect screens are installed.



### NOTE:

Infrared burners have no air adjustment.

### Air Shutter Settings

Model	Type of Gas	Main Burner	Rear Tube Burner
PRO665	Propane (G30,G31)	Open	* 1/4" (6 mm)

\* Each side of the air shutter

Table 1

## Stainless In Harsh Environments

Stainless steel oxidizes or stains in the presence of chlorides and sulfides, especially in coastal regions, warm and highly humid areas, and around pools and hot tubs. These stains look like rust, but they can be easily removed or prevented. Wash stainless and chrome surfaces every 3-4 weeks. Clean with warm soapy water.

### Burner Maintenance

- Extreme heat and a corrosive environment can cause surface corrosion to occur even though the burner is made from heavy wall 304 stainless steel.

### Maintenance and Protection of Infrared Burners

Your infrared burners are designed to provide a long service life, but you must be careful to prevent cracking of their ceramic surfaces. Fractures will cause the burners to malfunction



#### IMPORTANT!

- Damage resulting from by failure to follow these instructions is **NOT** covered by your grill warranty.

### Clearance Ventilation of Hot Air

- Hot air must have a way to escape the grill for the burners to function properly.
- The burners can become deprived of oxygen if the hot air is not allowed to escape causing them to back-flash. The ceramic can crack if this occurs repeatedly.

### Steps to Avoid Damaging Ceramic Surfaces

1. Never douse a flame or control flare-ups with water (**Fig. 20**).
2. Do not allow cold water (rain, sprinkler, hose etc.) to come in contact with hot ceramic burners. An immediate change in temperature will cause cracking of the ceramic tile.
3. A ceramic burner that becomes wet before use will create steam when operated later and produce pressure that will crack the ceramic.
4. Repeated soaking of the ceramic can cause it to swell and expand producing pressure that will make the ceramic crack and crumble.
5. Inspect the ceramic for possible water soaking if you find standing water in the grill. Remove the burner if the ceramic is wet. Turn it upside down to drain the excess water. Bring ceramic indoors to dry thoroughly.
6. Do not allow hard objects to impact the burner. Take care when inserting or removing cooking grids and using accessories.

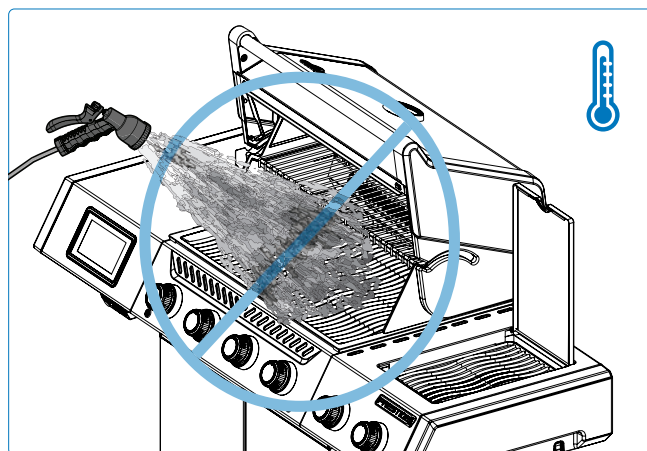

Fig. 20



#### DANGER!

- Turn off gas at the source and disconnect the unit before servicing.
- A leak test must be performed annually and when any component of the gas train is replaced, or when the smell of gas is present.
- Maintenance should only be done when the grill is cool to avoid the possibility of burns.



#### SAFETY FIRST!

Never cover more than 75% of any main or side burner cooking surface with any solid metal (e.g. griddles or pans)

## Door Adjustment

The appliance cart doors can be adjusted if they are uneven.

1. Locate the adjustment bracket at the top of the door (**Fig. 21**).
2. Using a screwdriver, turn the door adjustment screw clockwise to raise the door, or counterclockwise to lower it.
3. After one or two turns of the screwdriver, open and close the door and check alignment at the top of the doors.
4. Adjust the hinge screws to align the cabinet doors so they are level with each other (**Fig.21**).
5. If necessary, repeat these steps until the doors are aligned.

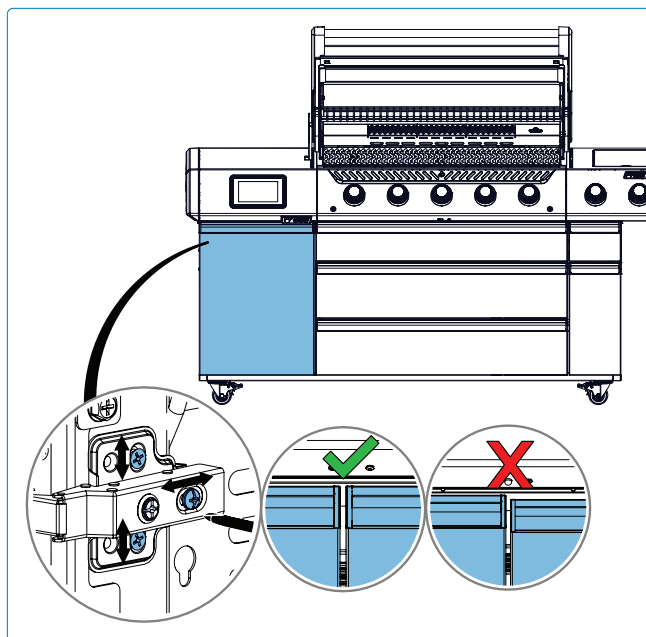

Fig. 21



### WARNING!

- Only elevate one side of the appliance at a time. Do not tilt the appliance forward or backward.

# Troubleshooting

## Lighting Problems

- Main, rear or side burners will not light with the igniter, but will light with a match.
- Burners will not cross light each other.

	Possible causes	Solution
Main Burner	JETFIRE™ outlet is dirty or clogged.	Clean JETFIRE™ outlet with a soft bristle toothbrush.
	Dirty or corroded cross light brackets.	Clean or replace as required.
Rear and Side Burners	Loose electrode wire or switch terminal wires.	Check electrode wire is firmly pushed onto the terminal on the back of the igniter. Check the lead wires from the module to the ignition switch (if equipped) are firmly pushed onto their respective terminals.
	Lifting flames on burner.	Close air shutter according to “ <b>Maintenance Instructions</b> ”- <b>Combustion Air Adjustment</b> section in this Owner’s Manual. IMPORTANT! This must be done by a qualified gas installer.

## Noises and Flare-ups

- Humming regulator.
- Excessive flare-ups and uneven heat.

Possible causes	Solution
Normal humming noise on hot days.	This isn’t a defect. It’s caused by internal vibrations in the regulator and doesn’t affect the performance or safety of the grill. Humming regulators WILL NOT be replaced.
The cylinder valve was opened too quickly.	Open cylinder valve slowly.
Sear plates installed incorrectly.	Ensure sear plates are installed with holes towards the front, and the slots on the bottom. See Assembly Instructions Guide.
Improper heating.	Preheat grill with all main burners on high for 10 to 15 minutes.
Excessive grease and ash build on sear plates and in drip pan.	Clean sear plates and drip pan regularly. Do not line pan with aluminum foil. Refer to “ <b>Cleaning Instructions</b> ”.

## Gas Flow

- Low heat or low flame when valve is turned to high.
- Burners burn with yellow flame, accompanied by the smell of gas.
- Flames lift away from burner, accompanied by the smell of gas, and possible lighting difficulties.
- Burner output on HIGH, but setting is LOW. Rumbling noise and fluttering blue flame at burner surface.

Possible causes	Solution
Propane – improper lighting procedure.	Ensure lighting procedure is followed carefully. All gas valves must be in the OFF position when the tank valve is turned on. Turn tank on slowly to allow pressure to equalize. See Operation – <b>"Lighting Instructions"</b> .
Natural gas – undersized supply line.	Pipe must be sized according to installation code.
Leaking gasket surrounding the ceramic tile, or a weld failure in the burner housing.	Allow burner to cool and inspect very closely for cracks. Contact your authorized Napoleon dealer to order replacement burner assembly if any cracks are found.
Both gas propane and natural gas – improper preheating.	Preheat grill with both main burners on high for 10 to 15 minutes.
Possible spider web or other debris.	Thoroughly clean nest or webs out of your burner orifice by removing it and following instructions in this manual. See <b>"Cleaning Instructions"</b> .
Improper air shutter adjustment.	Open or close air shutter slightly according to this manual. See <b>"Maintenance Instructions"</b> . <b>IMPORTANT!</b> This must be done by a qualified gas installer.
Lack of gas.	Check gas level in propane cylinder.
Supply hose is pinched.	Reposition supply hose as necessary.
Propane regulator in low flow state.	Turn the burners off and close the tank valve, wait 5 minutes before fully re-opening the valve, allow a few seconds for the pressure to equalize before following the Lighting Instructions to start the grill. Ensure igniting procedure is followed carefully every time you cook. All gas valves must be OFF when the tank valve is turned on. Always open the tank valve slowly.

## Peeling Paint

- Paint appears to be peeling inside lid or hood.

Possible causes	Solution
Grease build-up on inside surfaces.	This is not a defect. The finish on the lid and hood is porcelain or stainless steel and will not peel. The peeling is caused by hardened grease (known as creosote), which dries into paint-like shards, that flake off. Regular cleaning will prevent this. See " <b>Cleaning instructions</b> ".

## Infrared Burner Flashes Back

- During operation the burner abruptly makes a loud whoosh sound, followed by a continuous blow-torch type sound and grows dim or has a large flame on start up.

Possible causes	Solution
Ceramic tiles overloaded with grease drippings and build-up. Ports are clogged.	Turn burner OFF and allow to cool for at least 2 minutes. Reignite burner and burn on HIGH for at least 5 minutes, or until the ceramic tiles are evenly glowing red.
Burner overheated due to inadequate ventilation. Too much grill surface covered by griddle or pan.	Ensure no more than 75% of the grill surface is covered by objects or accessories. Turn burner OFF and allow to cool for at least 2 minutes. Reignite.
Leaking gasket surrounding the ceramic tile, or a weld failure in the burner housing.	Allow burner to cool and inspect very closely for cracks. Contact your authorized Napoleon dealer to order replacement burner assembly if any cracks are found.



### WE WANT TO HELP!

Napoleon is here to ensure your grilling experience is memorable. Contact us if you require additional help.

## Smoker

- Fails to start, doesn't reach or hold temperature, produces little or no smoke, or cooks food unevenly
- Makes unusual noises, shows error codes, creates excessive smoke, or has fuel feeding issues.

Possible causes	Cause	Solution
Smoker Not Turning ON	• Harness not connected to COMM port	• Plug in harness securely; inspect for damage
	• Power cable not plugged into smoker	• Plug power cable into smoker
	• Power cable not plugged into BBQ receptacle	• Plug power cable into BBQ receptacle
Wood Chips Not Igniting	• Wood chips are wet	• Use dry chips
	• Burnt chip buildup	• Clean tray
	• Door not shut properly	• Close door fully
Thick White Smoke	• Venturi system clogged or blower fan not running	• Clean system and check fan
	• Wet wood chips	• Replace with dry chips
	• Door not shut properly	• Ensure proper closure
	• Damaged or missing door seal	• Inspect and replace seal
Door Not Closing	• Chips jammed between tray and inner shell	• Clear obstruction
	• Ash/debris buildup	• Clean chamber
	• Tray misaligned	• Realign tray on track
White, Thick, or Bitter Smoke	• Incomplete combustion due to clogged Venturi	• Clean the Venturi system thoroughly
	• Incomplete combustion due to fan not running	• Inspect fan operation; if fan error is shown, follow diagnostic steps or contact support
	• Poor airflow or too much fuel	• Reduce fuel load and improve ventilation
	• Wet wood/chips smoldering	• Use dry wood chips or pellets

Possible causes	Cause	Solution
Integrated Smoker Malfunction (via LCD touchscreen)	<ul style="list-style-type: none"> <li>Grill not connected to power</li> </ul>	<ul style="list-style-type: none"> <li>Check power connection</li> </ul>
	<ul style="list-style-type: none"> <li>Smoker feature disabled in touchscreen settings</li> </ul>	<ul style="list-style-type: none"> <li>Enable smoker feature via LCD controls</li> </ul>
	<ul style="list-style-type: none"> <li>COMM wire not connected</li> </ul>	<ul style="list-style-type: none"> <li>Connect COMM wire securely</li> </ul>
	<ul style="list-style-type: none"> <li>Blown fuse</li> </ul>	<ul style="list-style-type: none"> <li>Replace fuse</li> </ul>
	<ul style="list-style-type: none"> <li>Wiring issues</li> </ul>	<ul style="list-style-type: none"> <li>Inspect connections</li> </ul>
	<ul style="list-style-type: none"> <li>Loose or faulty wired connections on back of LCD touchscreen</li> </ul>	<ul style="list-style-type: none"> <li>Check and secure touchscreen wiring</li> </ul>
	<ul style="list-style-type: none"> <li>System needs reset</li> </ul>	<ul style="list-style-type: none"> <li>Follow manufacturer’s reset instructions via touchscreen</li> </ul>
No Smoke or Very Little Smoke	<ul style="list-style-type: none"> <li>Temperature too high</li> </ul>	<ul style="list-style-type: none"> <li>Lower temperature setting</li> </ul>
	<ul style="list-style-type: none"> <li>Wet or poor-quality wood chips</li> </ul>	<ul style="list-style-type: none"> <li>Use dry, high-quality chips</li> </ul>
	<ul style="list-style-type: none"> <li>Incomplete combustion due to fan not running</li> </ul>	<ul style="list-style-type: none"> <li>Inspect fan operation; if fan error is shown, follow diagnostic steps or contact support</li> </ul>
	<ul style="list-style-type: none"> <li>Poor airflow due to clogged venturi</li> </ul>	<ul style="list-style-type: none"> <li>Clean the Venturi system thoroughly</li> </ul>
	<ul style="list-style-type: none"> <li>Ash buildup in woodchip tray</li> </ul>	<ul style="list-style-type: none"> <li>Clean woodchip tray regularly</li> </ul>

## Pairing the App with the Appliance

- On the display, always ensure that the Bluetooth® and Wi-Fi logo icon is flashing, indicating it is ready to pair with a smart device.

App Problem	Possible Causes / Solution
<p>The app is not installed or is not properly installed.</p>	<ul style="list-style-type: none"> <li>• Connect to Internet via Wi-Fi and download the app from the Apple App Store or Google Play™.</li> <li>• Follow prompts to automatically install and open the app.</li> <li>• Uninstall and reinstall app if needed (see "Napoleon Home App" for more details).</li> <li>• Expand app permissions.</li> <li>• Check the app icon on home screen.</li> </ul>
<p>The app is installed but shows a screen with a "probe is not connected" text.</p>	<ul style="list-style-type: none"> <li>• Ensure probes are properly inserted into the slots on your appliance.</li> <li>• Maximize receptivity by facing the display on the appliance with the smart device in close range.</li> <li>• Completely close the app and restart it (be familiar with your device's basic operations and settings).</li> <li>• Close out any unnecessary programs on the smart device that may be consuming memory.</li> </ul>
<p>The app worked before, but the device name is not listed in the app device list.</p>	<ul style="list-style-type: none"> <li>• App is not searching or not able to find the device.</li> <li>• Click "Try Again" on the "no devices found" page or hit the back button on the "devices found" page to restart scan.</li> <li>• Turn the display off and on by holding the power button for 5 seconds. Ensure Bluetooth® is activated in the mobile smart device settings.</li> <li>• Bring the smart device close to the display unit.</li> <li>• Refresh the memory cache by closing and reopening the app.</li> <li>• Ensure your device's location setting is turned on.</li> <li>• Wait between 30 and 60 seconds between steps.</li> </ul>

App Problem	Possible Causes / Solution
<p>The appliance lost the connection while in operation and shows a "connection lost" page.</p>	<ul style="list-style-type: none"> <li>• Try to locate cause of frequency interference or physical obstruction.</li> <li>• Ensure both the appliance and smartphone have internet access, and Bluetooth® is enabled on your smartphone.</li> <li>• Toggle the display unit off and on.</li> <li>• Force close and reopen the app as a last resort.</li> </ul>
<p>The alarms are not working.</p>	<ul style="list-style-type: none"> <li>• Check the device connection.</li> <li>• Check appropriate sounds or notifications are turned on in your smart device settings.</li> <li>• Check that alarm (or vibrate) notification is selected in the Napoleon Home App.</li> </ul>
<p>The appliance will not connect to Wi-Fi.</p>	<ul style="list-style-type: none"> <li>• The appliance only supports the 2.4GHz Wi-Fi band. Check your router settings. Ensure your router is broadcasting in 2.4GHz. Some routers have the ability to broadcast in multiple bands.</li> <li>• Check your router's settings to ensure the 2.4GHz band is enabled.</li> <li>• Other electronic devices can interfere with the Wi-Fi signal. Try moving the device away from electronics that might be causing interference.</li> </ul>



**PARTS  
RESOURCES**

Go to [napoleon.com](http://napoleon.com)  
or your Assembly  
Guide for replacement  
parts instructions.

# Diagram for Electrical Connections

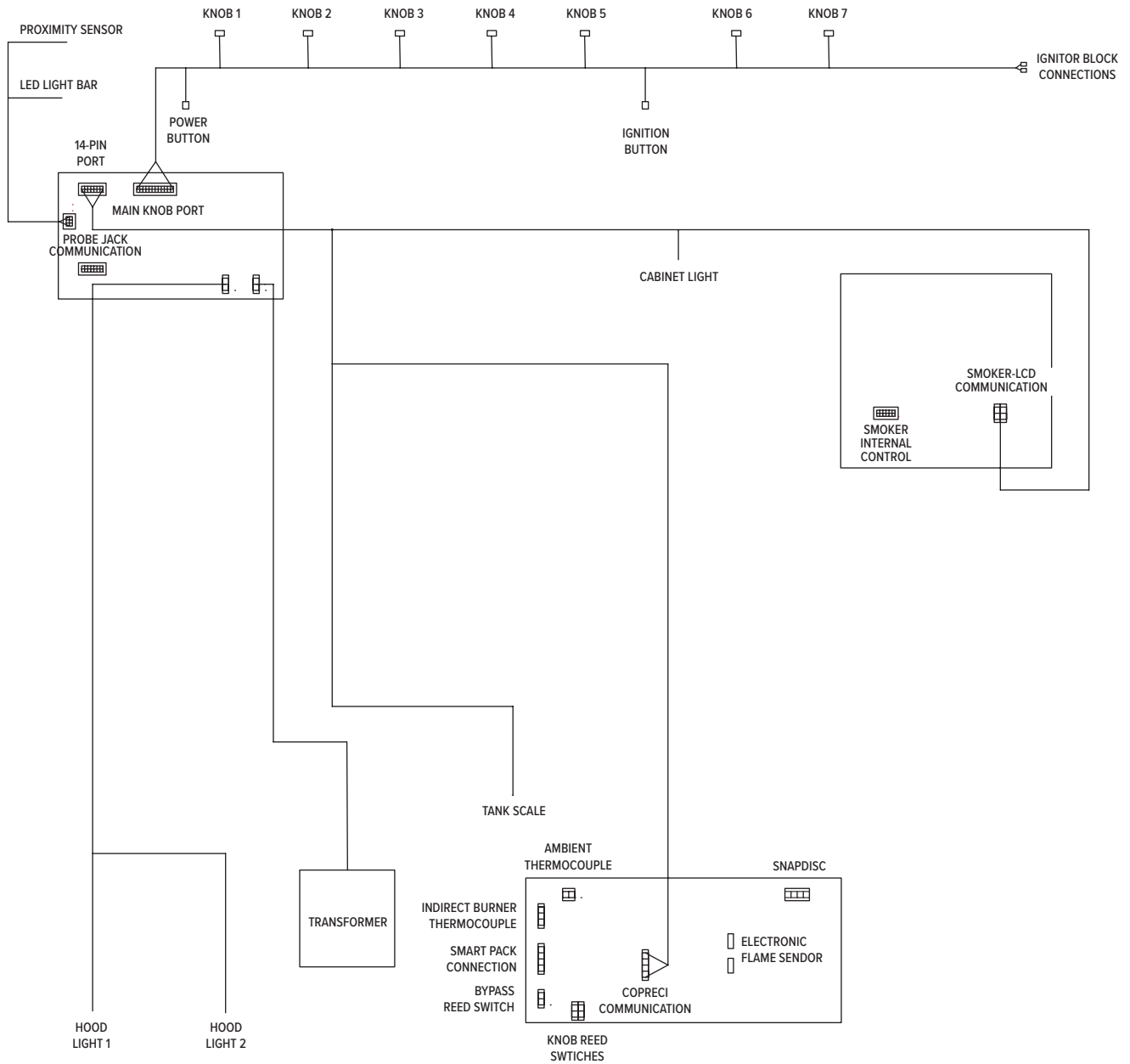

# NAPOLEON®

## LIMITED LIFETIME WARRANTY

### FOR PRESTIGE®, PRESTIGE PRO™ AND BUILT-IN SERIES MODELS



Napoleon products are designed with superior components and materials and are assembled by trained craftsmen who take great pride in their work. The burner and valve assembly are leak tested and test-fired at a quality test station. This grill has been thoroughly inspected by a qualified technician before packaging and shipping to ensure that you, the customer, receive the quality product you expect from Napoleon.

Thank you for purchasing a Napoleon product. Napoleon (Wolf Steel Ltd, Barrie, ON, Canada) warrants that the components in your new Napoleon product will be free from defects in material and workmanship from the date of purchase, for a period of 15 years.

Hood.....	Lifetime
Stainless Steel Lid.....	Lifetime
Porcelain Enamel Lid.....	Lifetime
Aluminum Castings.....	Lifetime
Stainless Steel Cooking Grids.....	Lifetime
Stainless Steel Tube Burners.....	Lifetime
Stainless Steel Sear Plates.....	15 Years
Porcelain Enamel Cast Iron Grids.....	15 Years
Stainless Steel Infrared Rotisserie.....	15 Years
Infrared Bottom/Side Burner.....	15 Years
Electrical Components.....	3 Years
All Other Parts.....	15 Years

#### Conditions and limitations:

This Limited Warranty creates a warranty period as specified in the aforementioned table, for products purchased through an authorized Napoleon dealer, and entitles the original purchaser (or gift recipient in the case where a new product is given as a gift) to the specified coverage in respect of any component replaced within the warranty period, either by Napoleon or an authorized Napoleon dealer, to replace a component of such product that has failed in normal private use as a result of a manufacturing defect. This warranty does not cover accessories or bonus items.

For greater certainty, “normal private use” of a product means that the product: has been installed (where applicable) by a licensed, authorized service technician or contractor, in accordance with the installation instructions included with the product and all local and national building and fire codes; has been properly cleaned and maintained according to the instructions; and has not

been used as a communal amenity or in a commercial application. In the case of use in communal or commercial applications (where approved), the warranty is reduced to a period of two (2) years.

Similarly, “failure” does not include: damage caused by over-firing, blow outs caused by environmental conditions such as strong winds or inadequate ventilation, scratches, dents, corrosion, deterioration of painted and plated finishes, discoloration caused by heat, abrasive or chemical cleaners or UV exposure, chipping of porcelain enameled parts, or damages caused by misuse, accident, hail, grease fires, lack of cleaning and maintenance, hostile environments such as salt or chlorine, alterations, abuse, neglect or parts installed from other manufacturers. If you live in a coastal area, or have your product located near a pool or hot tub, maintenance includes regular washing and rinsing of the exterior surfaces as outlined in the accompanying owner’s manual, in order to prevent surface corrosion.

# NAPOLEON<sup>®</sup>

## LIMITED LIFETIME WARRANTY

### FOR PRESTIGE<sup>®</sup>, PRESTIGE PRO<sup>™</sup> AND BUILT-IN SERIES MODELS

Should deterioration of parts occur to the degree of non-performance (rusted through or burnt through) within the duration of the warranted coverage, a replacement part will be provided. Parts replaced under this warranty are warranted only for the balance of the period specified in the aforementioned table.

The replacement component is the sole responsibility of Napoleon defined by this warranty; in no event will Napoleon be responsible for installation, labor or any other costs or expenses related to the re-installation of a warranted part, for any incidental, consequential or indirect damages, or for any handling and transportation charges or export duties.

The use and/or installation of parts on your Napoleon product that are not genuine Napoleon parts will void this warranty, and any damages that result hereby are not covered by this warranty. Any conversion of a gas grill not authorized by Napoleon and performed by a Napoleon authorized service technician will void this warranty.

This warranty is provided in addition to any rights afforded to you by local laws. These and other statutory rights remain unaffected by this warranty provision.

Accordingly, this warranty imposes no obligation upon Napoleon to keep parts in stock. Based on the availability of parts,

Napoleon may at its discretion discharge all obligations by providing a customer a prorated credit towards a new product. Napoleon may from time to time update the design of its products. Nothing contained in this warranty shall be construed as obligating Napoleon to incorporate such design updates into previously manufactured products, nor shall such updates be construed as an admission that previous designs were defective.

Registering your Napoleon product confirms your warranty coverage, will expedite any warranty claims you may need to make, and provides a link between you and Napoleon in case we ever need to contact you. When making warranty claims, Napoleon representatives may request from you the bill of sale or copy, together with a serial number and a model number. Napoleon reserves the right to have its representative inspect any product or part prior to honoring any warranty claim. You must contact Napoleon Customer Service or an authorized Napoleon dealer to obtain the benefit of the warranty coverage.



# 50 Years of Home Comfort Solutions.



NAPOLEON® products are protected by one or more U.S. and Canadian and/or foreign patents or patents pending.



### Address

**Wolf Steel Ltd.**  
De Riemsdijk 22, 4004 LC,  
Tiel, The Netherlands  
10-12 Home Farm, Meriden Road,  
Berkswell, CV7 7SL,  
United Kingdom  
24 Napoleon Road, Barrie,  
Ontario, L4M 0G8, Canada



### Telephone

Europe  
+31 (0) 88 588 66 55

### Online

✉ [eu.info@napoleon.com](mailto:eu.info@napoleon.com)  
🌐 [www.napoleon.com](http://www.napoleon.com)