









HEKMAN®

A HOWARD MILLER COMPANY

24803 SLAB TOP COFFEE TABLE

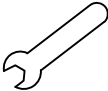
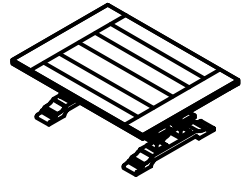
HARDWARE LIST							
A	B	C	D	E	F	G	H
BOLT M8 x 100 2 PCS.	HALF WASHER M8 2 PCS.	HEXAGON NUTS M8 (2 PCS.)	ALLEN BOLT M6 X 35 (4 PCS)	FLAT W. M6 4 PCS.	SPRING W. M8 4 PCS.	ALLEN KEY M4 (FOR ALLEN BOLT) 1 PC.	WRENCH (FOR HEXA BOLT) 1 PC.
							

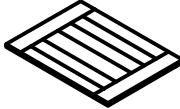

PART INSIDE		
1	2	3
TOP PANEL (1 Pc)	WOOD LEG (2 Pcs)	STRETCHER (1 Pc)
		

Assembly Instruction

STEP 1:

INSERT CONNECTING BOLT (A) INTO LEG ASSEMBLIES. PLACE STRETCHER IN POSITION AND LOCK WITH HALFMOON WASHER (B), HEXAGON NUTS (C) USING WRENCH (H) PROVIDED.

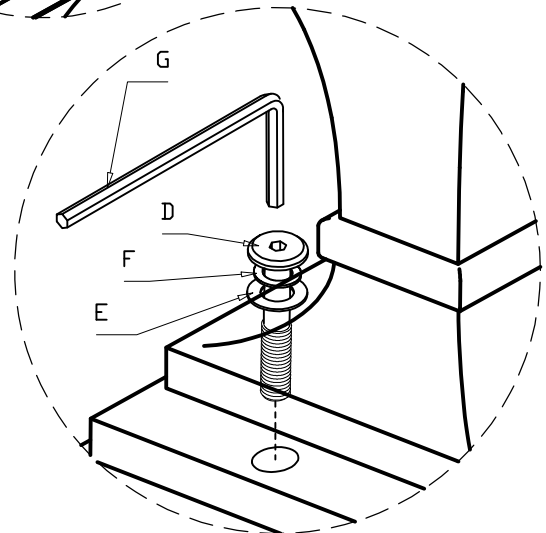
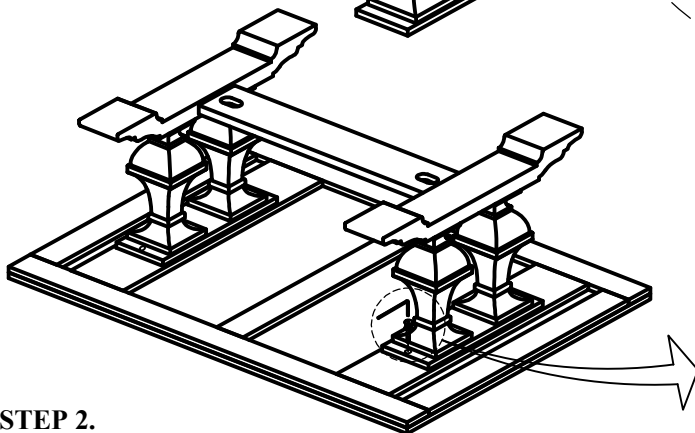
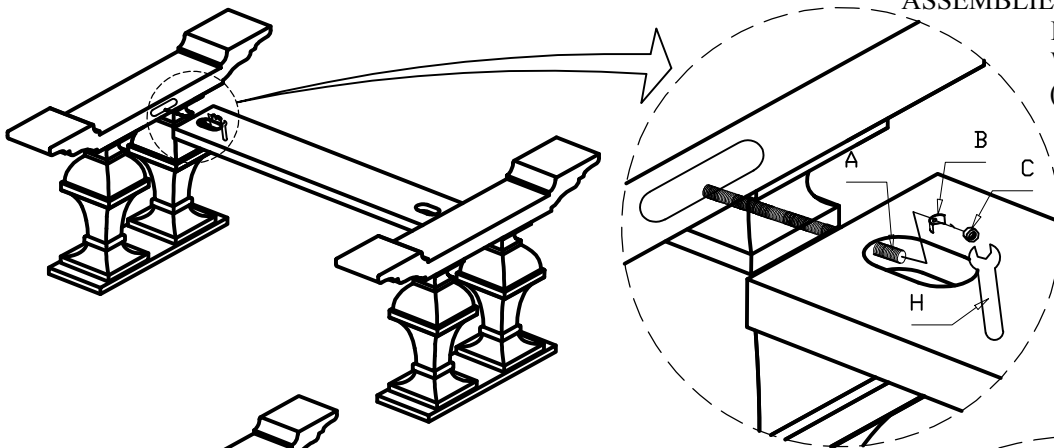

STEP 2.

LAY TOP PANEL UPSIDE DOWN ON A SOFT, CLEAN AND FLAT SURFACE. ALIGN THE HOLES IN THE TOP PLATE OF THE LEG ASSEMBLIES WITH THE INSERT IN THE BOTTOM PANEL OF THE TOP ASSEMBLY. CONNECT USING FLAT WASHER (E), SPRING WASHER (F), ALLEN BOLT (D) AND ALLEN KEY (G) PROVIDED.