

# **ELURA**

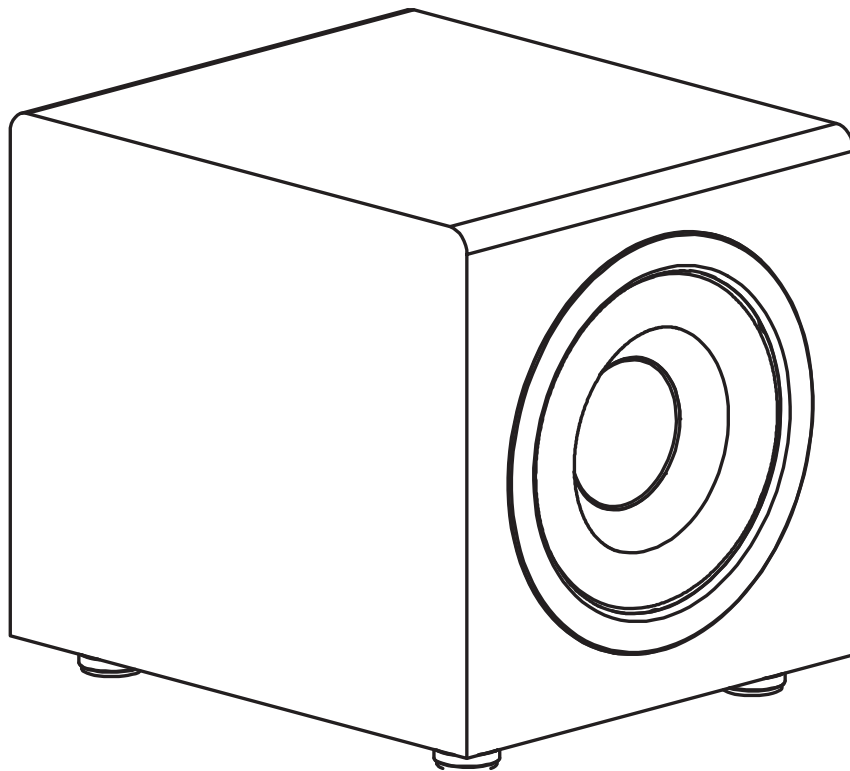

---

**SOUND + PERFORMANCE**

**RED LABEL SERIES SUBWOOFERS  
OWNER'S MANUAL**



**ELURA SUBR66-MINI  
DUAL 6" 400-WATT  
POWERED SUBWOOFER**

	<b>CAUTION</b> RISK OF ELECTRIC SHOCK DO NOT OPEN	<b>ATTENTION</b> RISQUE DE CHOC ELECTRIQUE NE PAS OUVRIR	
<b>WARNING:</b>			
To reduce the risk of fire or electric shock, do not expose this apparatus to rain or moisture.			
<b>AVIS:</b>			
<b>Pour réduire le risque d'incendie ou de choc électrique, ne pas exposer cet appareil sous la pluie et l'humidité.</b>			
The apparatus shall not be exposed to dripping or splashing and that no objects filled with liquids, such as vases, shall be placed on apparatus.			
<i>L'appareil ne doit pas être exposé aux écoulements ou aux éclaboussures et aucun objet ne contenant de liquide, tel qu'un vase, ne doit être placé sur l'objet.</i>			



The lightning flash with arrowhead symbol, within an equilateral triangle, is intended to alert the user to the presence of uninsulated "dangerous voltage" within the product's enclosure that may be of sufficient magnitude to constitute a risk of electric shock to persons.

*Le symbole de l'éclair fléché dans un triangle équilatéral, est destiné à alerter l'utilisateur de la présence d'une "tension dangereuse" dans le boîtier du produit qui peuvent être des ampleur suffisante pour constituer un risque d'électrocution aux personnes.*



This symbol is intended to alert the user to the presence of important operation and maintenance (servicing) instructions in the literature accompanying the appliance.

*Ce symbole est destiné à alerter l'utilisateur de la présence d'opération et de maintenance (entretien) dans la documentation accompagnant l'appareil.*

## Important Safety Instructions

1. Read these Instructions.  
*Lisez ces instructions.*
2. Keep these Instructions.  
*Conservez ces instructions.*
3. Heed all Warnings.  
*Respectez tous les avertissements.*
4. Follow all instructions.  
*Suivez toutes les instructions.*
5. Do not use this apparatus near water.  
*Ne pas utiliser cet appareil près de l'eau.*
6. Clean only with a dry cloth.  
*Nettoyer uniquement avec un chiffon sec.*
7. Do not block any ventilation openings. Install in accordance with the manufacturer's instructions.  
*Ne pas bloquer les ouvertures de ventilation. Installer conformément aux instructions du fabricant.*
8. Do not install near any heat sources such as radiators, heat registers, stoves, or other apparatus (including amplifiers) that produce heat.  
*Ne pas installer près de sources de chaleur telles que radiateurs, registres de chaleur, poêles ou autres appareils (y compris les amplificateurs) produisant de la chaleur.*
9. Do not defeat the safety purpose of the polarized or grounding - type plug. polarized plug has two blades with one

wider than the other. When the provided plug does not fit into your outlet, consult an electrician for replacement of the obsolete outlet.

*Ne détruisez pas la sécurité de la terre ou polarisées - fiche. Une fiche polarisée possède deux lames dont une est plus large que l'autre. Si la fiche fournie ne rentre pas dans votre prise, consultez un électricien pour remplacer la prise obsolète.*

10. Protect the power cord from being walked on or pinched particularly at plugs, convenience receptacles, and the point where they exit from the apparatus.

*Protégez le cordon d'alimentation d'être piétiné ou pincé, particulièrement au niveau des fiches, des prises, et le point où ils sortent de l'appareil.*

11. Only use attachments/accessories specified by the manufacture .  
*N'utilisez que des accessoires spécifiés par le fabricant.*

12. Use only with a cart, stand, tripod, bracket, or table specified by the manufacturer, or sold with the apparatus. When a cart or rack is used, use caution when moving the cart/apparatus, combination to avoid injury from tip-over.



*Utilisez uniquement un chariot, stand, trépied, support ou table spécifiés par le fabricant ou vendu avec l'appareil. Quand un panier ou rack est utilisé, faites attention lorsque vous déplacez l'ensemble chariot / appareil, pour éviter d'éventuelles blessures en cas de chute.*

13. Unplug this apparatus during lightning storms or when unused for long periods of time.

*Débranchez cet appareil pendant les orages ou lorsqu'il n'est pas utilisé pendant de longues périodes de temps.*

14. Refer all servicing to qualified service personnel. Servicing is required when the apparatus has been damaged in any way, such as power-supply cord or plug is damaged, liquid has been spilled or objects have fallen into the apparatus, the apparatus has been exposed to rain or moisture, does not operate normally, or has been dropped.

*Confiez toute réparation à un personnel qualifié. Une réparation est nécessaire lorsque l'appareil a été endommagé de quelque façon que ce cordon d'alimentation ou la fiche est endommagé, liquide a été renversé ou des objets sont tombés dans l'appareil, l'appareil a été exposé à la pluie ou à l'humidité, ne fonctionne pas normalement, ou s'il est tombé.*

15. **WARNING:** The mains plug (appliance coupler) is used as disconnect device, the disconnect device shall remain readily operable.

*AVERTISSEMENT: La fiche d'alimentation (appareil coupleur) est utilisé comme dispositif de déconnexion, le dispositif de déconnexion doit rester facilement accessible.*

16. No naked flame sources, such as lighted candles, should be placed on the apparatus.

*Aucune source de flamme nue, telle que des bougies allumées, ne doit être placé sur l'appareil*

17. Protective earthing terminal. The apparatus should be connected to a mains socket outlet with a protective earthing connection.



*Borne de terre de protection. L'appareil doit être connecté à une prise secteur avec une prise de terre.*

# TABLE OF CONTENTS

A. UNPACKING .....	3
B. AMPLIFIER PANEL TOUR .....	3
C. PLACEMENT .....	4
D. CONNECTIONS .....	4
E. INITIAL LISTENING TESTS .....	7
F. SPECIFICATIONS .....	8
G. TROUBLESHOOTING & SERVICE .....	8
H. WARRANTY .....	8

**C**ongratulations on your purchase of an Elura SUBR66-MINI powered subwoofer. It will give your stereo or home theater system unparalleled low frequency output.

Bass frequencies are critical to realistic sound reproduction. After you've hooked up your SUBR66-MINI subwoofer, you'll discover just how much "punch" and depth you've been missing. No matter what kind of music or videos you listen to... whether you listen to it loud or soft, you'll experience sound that's richer and fuller. Bass guitar and string bass will have more impact. You'll be able to FEEL as well as hear percussion - just the way you would at a live performance. If you have an audio/video system, movies will come alive with thunderous sound effects that were never possible without the Elura SUBR66-MINI.

The Elura SUBR66-MINI is a self-powered subwoofer that frees your receiver or powered amplifier from the power demands of reproducing very low frequencies. To do this, the sub incorporates its own built-in crossover system that automatically "assigns" lower frequencies to its own power amplifier, contained within the sub enclosure.

The Elura SUBR66-MINI has been meticulously designed and tested to ensure high performance, durability, and longevity.

This manual is designed to take you step-by-step through the hookup and operating process. Reading this manual carefully will ensure that you get maximum performance from your new Elura SUBR66-MINI.

## A. UNPACKING

Remove the Elura SUBR66-MINI from its packing carefully and inspect it for any shipping damage. If you discover damage, contact your dealer or installer immediately.

If possible, save the carton and internal packing. It's the best possible protection for you SUBR66-MINI if you need to move it or return it for service.

Keep your sales receipt in a secure place. It helps establish the duration of your warranty (just in case anything happens to your stereo/home theater system).

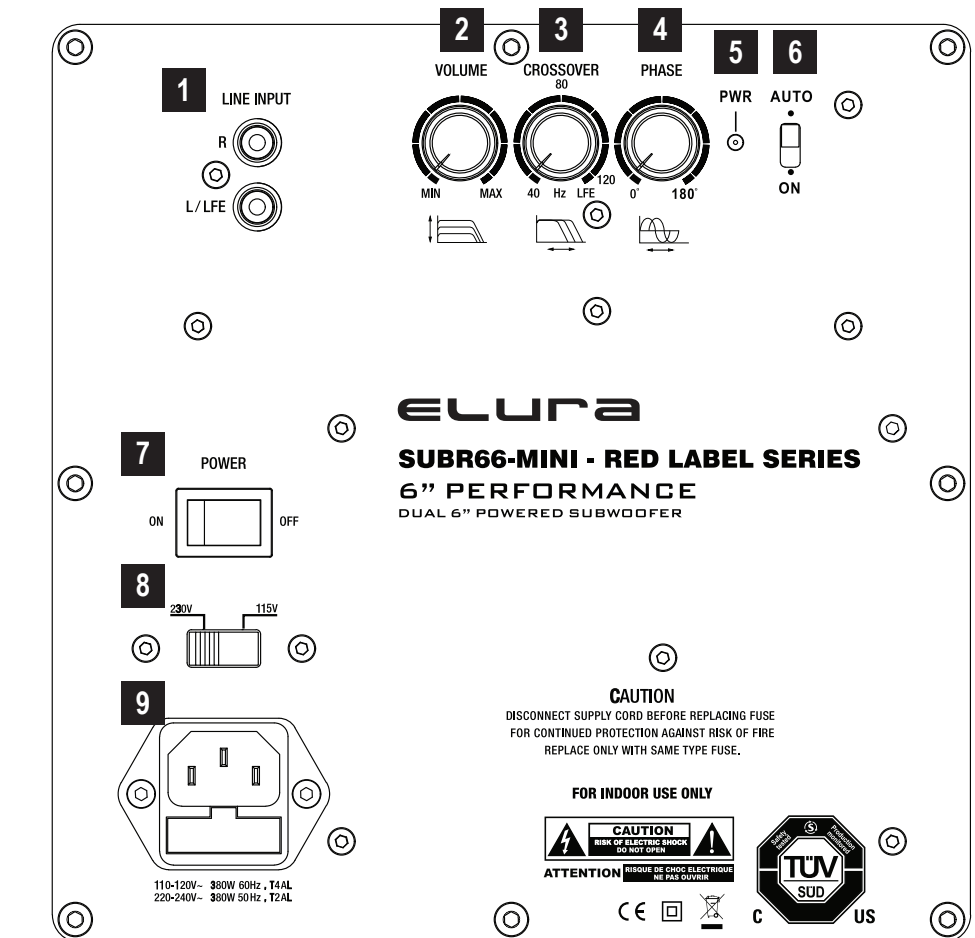

FIG. 1 - Elura SUBR66-MINI Rear Panel

## B. AMPLIFIER PANEL TOUR

Before actual hookup, you should familiarize yourself with the connections on the back of the SUBR66-MINI as shown in FIG. 1.

**1. LFE/SUBWOOFER/LOW LEVEL LINE IN** (line level connections). These connections are used if you have a preamplifier or a receiver/integrated amplifier which has LFE, subwoofer, or line level outputs that follow the volume control, or to connect to the line-level audio output of a flat panel TV.

**2. VOLUME CONTROL.** Rotating this knob clockwise increases the output level of the subwoofer. To start out, make sure that the VOLUME is turned all the way down (fully counterclockwise). Later, after some initial testing, you can adjust the volume to your own taste. However, care should be taken not to overdrive the subwoofer to the point of audible distortion.

**3. CROSSOVER FREQUENCY CONTROL.** This control determines what lower part of the frequency spectrum will be reproduced by the sub. It is a "crossover" control. Rotating the knob sets the point where all lower frequencies will be handled by the subwoofer. As a starting point, set the control around 80Hz if you are using left/right tower speakers, 80-120Hz with bookshelf or small mini speakers.

**4. PHASE CONTROL.** This control is used to set the subwoofer's phase between normal "0°" or reverse "180°" (out of phase). Once you determine the placement of the sub, you will need to vary this control for the best bass output for your listening position. The physical location of your subwoofer and main speakers determines the phase setting that will sound best.

**5. POWER INDICATOR:**

OFF = No Color  
STANDBY = Red  
ON = Green

**6. AUTO/ON SWITCH.** This switch turns the sub on or into AUTO mode. When this switch is in the AUTO position, the amplifier will stay turned on as long as a signal is being fed to the subwoofer amplifier. Approx 8 minutes after you stop playing music or a video, the amplifier goes into STANDBY mode. When you again begin to play music or a video, the amplifier will automatically turn on. With the switch in the ON mode the amplifier will stay on indefinitely.

**7. MASTER POWER SWITCH**

**8. VOLTAGE SELECTION SWITCH.** This comes set to 115V from the factory.

**9. FUSE & PLUG FOR REMOVABLE AC POWER CORD.**

## C. PLACEMENT

### Where to position your Elura SUBR66-MINI

The Elura SUBR66-MINI operates at low bass frequencies which are essentially omni-directional. That means you can place the Elura SUBR66-MINI almost anywhere in a room without compromising the effectiveness of your main stereo speakers.

Four factors need to be considered:

1. distance from your main speakers;
2. distance from a wall outlet;
3. distance from your receiver, amplifier, and/or flat panel TV; and,
4. proximity to walls and corners.

**CAUTION:** The Elura SUBR66-MINI are not magnetically-shielded. If used with an older CRT monitor or TV, keep it at least 2 feet from the monitor.

**1. Distance from your main speakers.** The best placement for your subwoofer is on the same wall as the main speakers, especially if you are matching up with small bookshelf speakers. With tower speakers, side wall or rear placement is also acceptable.

**2. Wall outlet.** Since the Elura sub requires AC power, it must be placed where it will reach a wall outlet. We don't recommend extending that range with an extension cord.

**3. Connections to you receiver, amplifier, preamplifier or video display.** You will need to connect the subwoofer to your receiver subwoofer output or LFE output, video display or preamp line level outputs (see next page). You can basically place the Elura SUBR66-MINI anywhere in a normal-sized room.

**4. Proximity to walls and corners.** Physical placement of the subwoofer will have a definite impact on the frequency response and the perceived amount of bass output. Because low frequencies have long wavelengths, they are influenced by proximity to a boundary such as a wall or floor.

See FIG. 2. When you place the Elura SUBR66-MINI well away from a wall, it will produce bass at a certain level. Move the subwoofer close to the wall, it will produce more output (about 3dB more). Putting the subwoofer in a corner will increase output another 3dB (6dB more than when placed away from walls and corners).

All this technical jargon may sound confusing, but it basically means that you have a number of options, each of which produces a different amount of bass. For example, if you like a lot of heavy bass, consider putting the Elura SUBR66-MINI into a corner. If you like smoother, less obvious bass, move the subwoofer out into the room. The main thing to remember is that there is no right or wrong place to put the Elura SUBR66-MINI. It all depends on how much bass you want.

Another reason to experiment - because low bass waves are very large (up to 50 feet or more across), they tend to cancel and reinforce each other, causing places in the room where there is a lot of bass and others where there isn't very much at all. If you walk around your listening room while playing music, you'll probably discover these sorts of areas where bass is either exaggerated or reduced. Needless to say, if your main listening area ends up in a "dead" space, you will need to move the Elura SUBR66-MINI so that bass is more normal.

Incidentally, moving the sub around won't affect the stereo imaging of your main stereo system, so feel free to try various subwoofer positions.

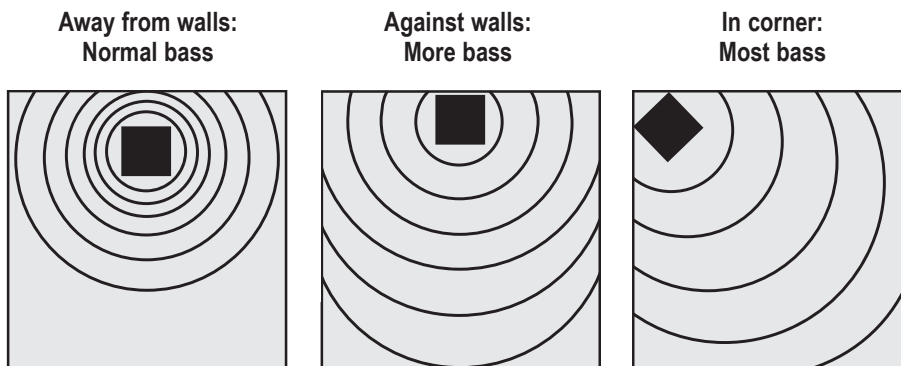

FIG. 2 - Elura SUBR66-MINI Placement

### Connecting to a wall plug

The Elura SUBR66-MINI draws a moderately high amount of current. We do not recommend plugging it into a convenience outlet (switched or unswitched) that is often found on the back of receivers and other stereo components.

Instead, connect the subwoofer ONLY to its own AC outlet. See items 9 and 10 in the Safety Instructions on Page 2 of this manual.

## D. CONNECTIONS

### Three basic connection options

1. **Connection to electronics with subwoofer or LFE output.** If you own a surround sound receiver or integrated amplifier with a subwoofer or LFE output, use Method A as shown in Fig. 3.
2. **Connection to stereo preamp and amplifier.** If you have separate preamp and amplifier, use Method B as shown in Fig. 4.
3. **Connection to flat-panel TV.** If you have a flat panel TV with stereo analog audio outputs, use Method C as shown in Fig. 5.

## SURROUND SOUND RECEIVER

NOTE: SEE ITEM 5 FOR PROPER RECEIVER TYPE SWITCH SETTING

## Method A: Line level hookup steps for receivers with subwoofer connections

(Refer to Fig. 3)

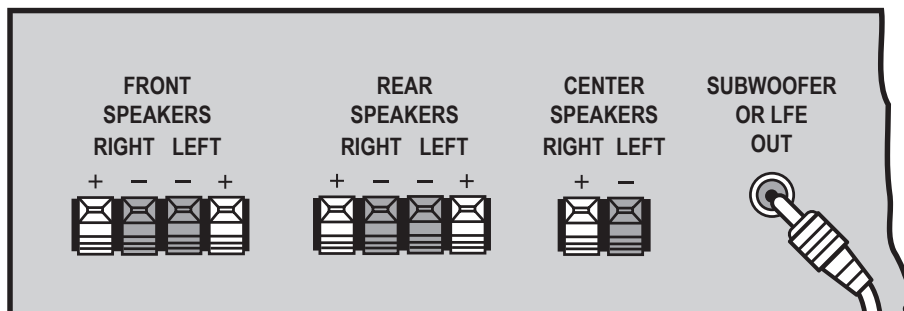

**NOTE:** This connection method is only for receivers that have a subwoofer or LFE output. You will need one line level RCA to RCA connector cable long enough to reach from your receiver to your Elura SUBR66-MINI location.

**1. IMPORTANT:** Make sure that ALL system components including the Elura SUBR66-MINI are turned OFF before proceeding.

2. Locate the subwoofer or LFE output connector on the rear of your receiver and connect one end of the RCA line level cord to it.

3. Route the line cord to the subwoofer location (trying to minimize areas where it may be stepped on) and connect the other end directly to the subs' LINE IN L or LFE input.

4. Connect your main (and surround speakers if applicable) to the receiver according to the receiver's owner's manual.

5. **Note:** If you are using a Dolby Digital type receiver with built-in crossover, you must set the crossover frequency in your receiver (check your receiver's owner's manual). Set the subwoofer's crossover to 120Hz.

6. You are now ready to put your Elura SUBR66-MINI subwoofer into use. Skip to "E - INITIAL LISTENING TEST".

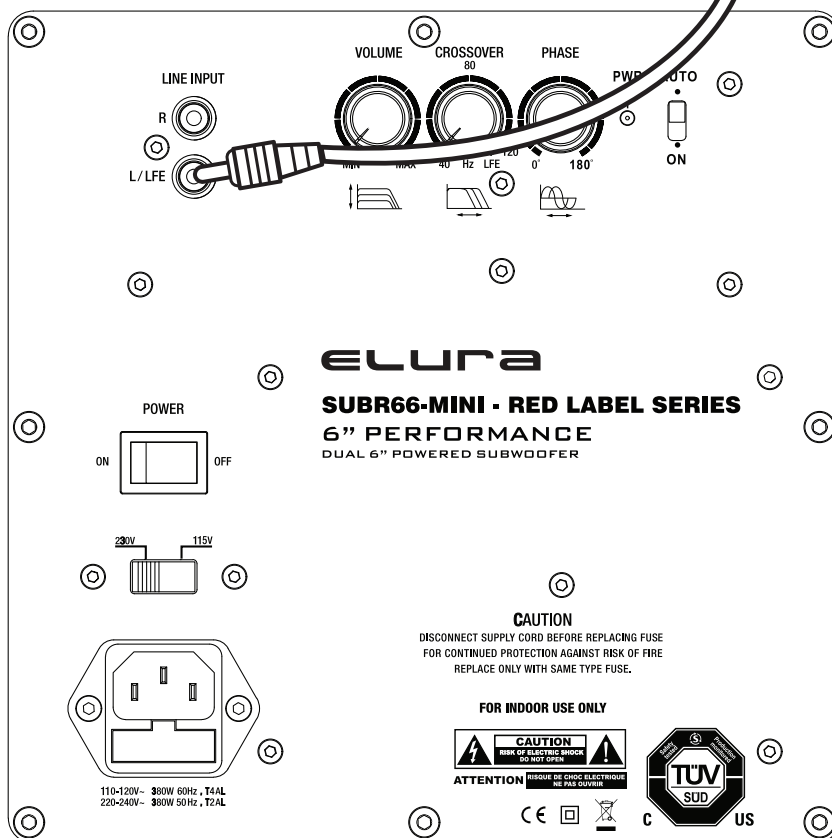

FIG. 3 - Hookup for Surround Sound Receiver with a Subwoofer Output

## Method B: Line level hookup steps for systems with preamplifier and power amplifier

(Refer to Fig. 4)

- IMPORTANT:** Make sure that ALL system components including the Elura SUBR66-MINI are turned OFF before proceeding.
- Locate the LINE output RCA sockets on the back of your preamplifier. These are typically marked PRE, PRE OUT, LINE OUT, or TO POWER AMP depending on the make and model of the component.
- Connect a set of high-quality line level RCA male to dual female Y-connectors to the preamp's LINE OUT sockets. Then connect a pair of high-quality line level cables from the Y-connectors to the left and right LINE IN of your subwoofer. Make sure that the left is connected to the left and the right is connected to the right.
- Connect another set of connection cables between Y-connectors and the MAIN INPUTS of your power amplifier. Again, make sure that the left and right are connected correctly.
- Connect your main speakers to the speaker terminals on the back of your power amplifier.
- You are now ready to put your Elura SUBR66-MINI subwoofer into use. Skip to "E - INITIAL LISTENING TEST".

Y CONNECTORS

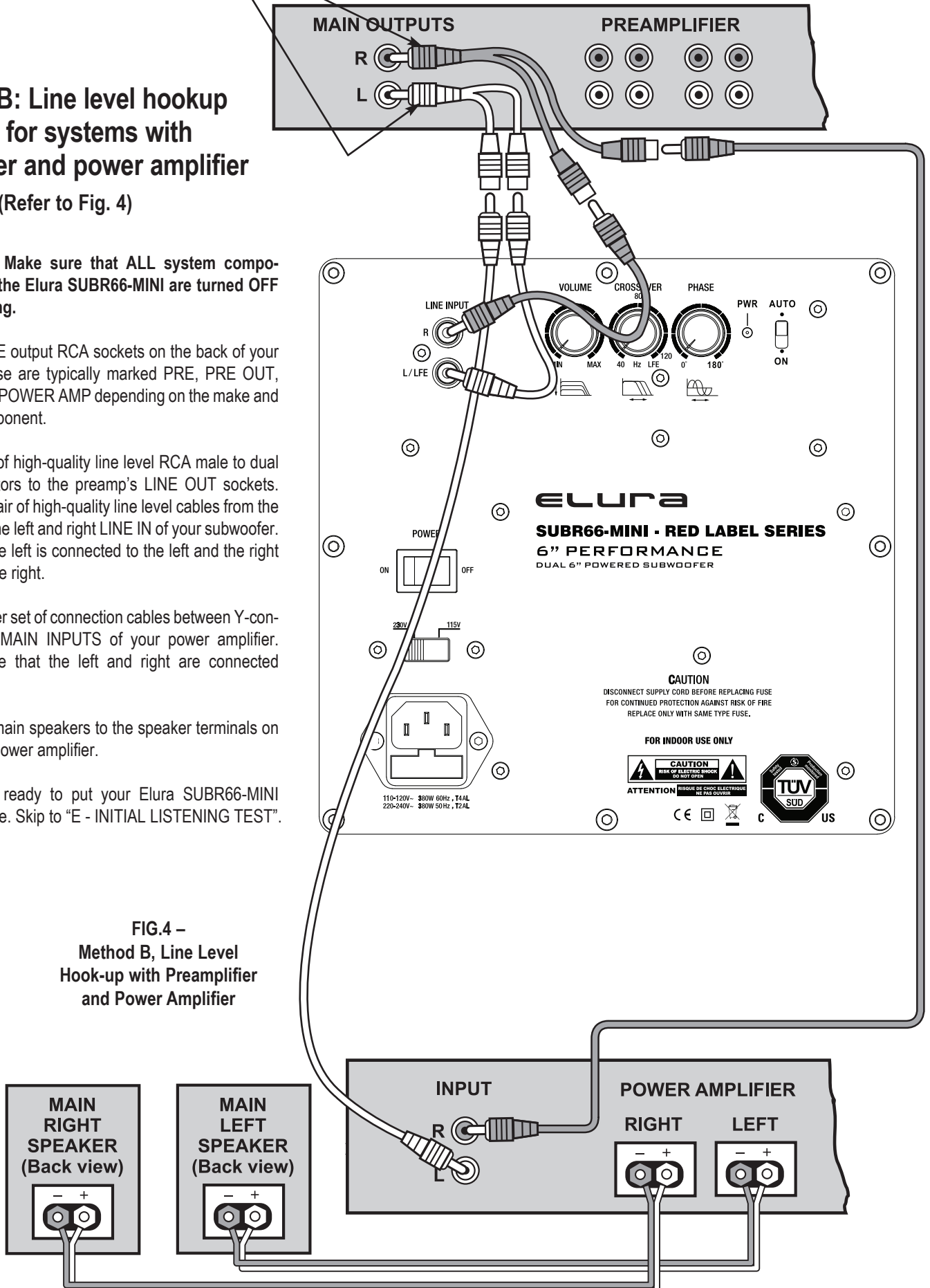

**FIG.4 –**  
Method B, Line Level  
Hook-up with Preamplifier  
and Power Amplifier

## Method C: Line level hookup steps for flat panel TVs

(Refer to Fig. 5 below)

**1. IMPORTANT: Make sure that ALL system components including the Elura SUBR66-MINI are turned OFF before proceeding.**

2. Connect a set of high-quality line level connection cables (patch cords) between the TV analog audio output connectors and the LINE IN sockets on the back of the SUBR66-MINI. Make sure that the left and right are connected correctly.

3. You are now ready to put your Elura SUBR66-MINI subwoofer into use. Skip to "E - INITIAL LISTENING TEST".

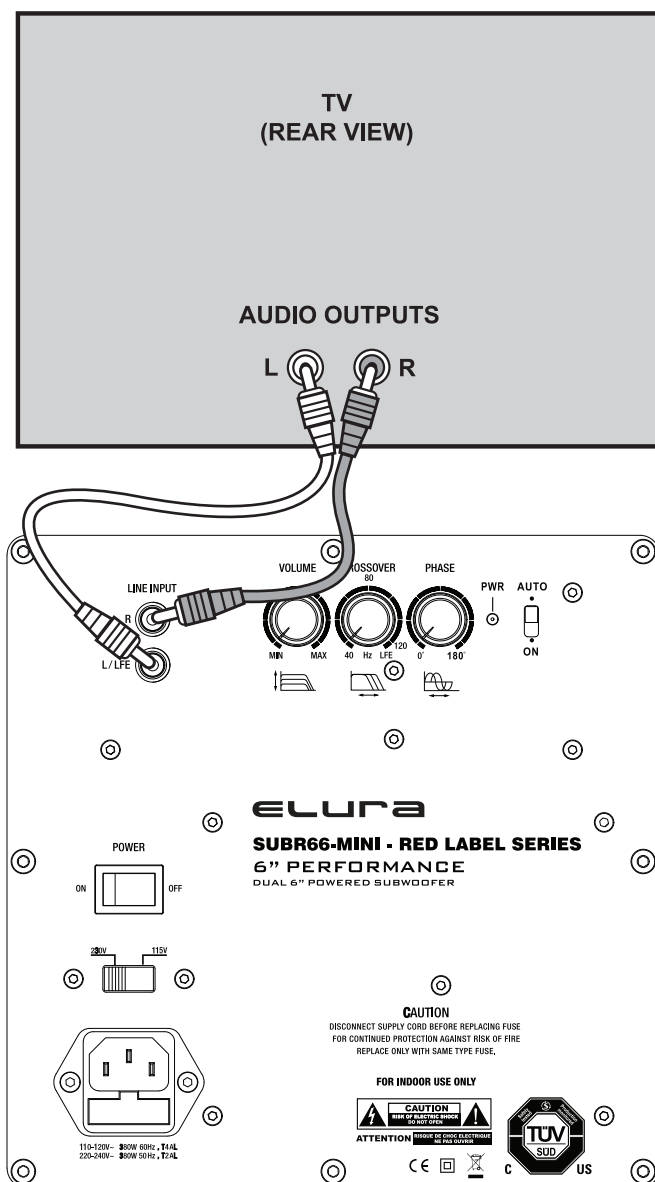

FIG.5 – Method C, Line Level Hook-up with Flat Panel TV

## E. INITIAL LISTENING TEST

It's now time to introduce the Elura SUBR66-MINI amplifier's potent and plentiful bass into your listening environment.

1. Double check all connections.

2. Make sure that the volume controls on both the SUBR66-MINI and your receiver/integrated amp/preamp/TV are turned all the way down (fully counterclockwise). Set the PHASE control to zero. Set the CROSSOVER FREQUENCY knob to 80Hz for normal operation, or to 120 HZ for Dolby Digital operation where the proper frequency is set in the receiver's crossover.

3. Turn on your stereo/home theater system. THEN turn on the Elura SUBR66-MINI. Confirm that the subwoofer's POWER indicator is glowing green. If it isn't, check the power connections between the sub and the wall socket.

4. Play a musical selection or movie that you are familiar with. Pick a song that has regular low bass beats. Advance the receiver/integrated amp/preamp/TV's volume control up to a normal listening level. If you don't hear sound through your main speakers, turn off the system and check connections. Also consult the trouble-shooting tips on Page 8.

5. If sound is coming out of your main speakers, turn the VOLUME control clockwise until you hear noticeable additional bass. If you don't hear bass by the time you have advanced the subwoofer's VOLUME control halfway, turn off the system and check connections. Consult the troubleshooting tips on Page 8.

6. Adjust the SUBR66-MINI's VOLUME control until you are satisfied with the amount of bass. You may want to try several different albums, genres, or movies while determining how high to adjust the Elura SUBR66-MINI's VOLUME. The amount of bass varies by medium.

7. Now that you have adjusted the quantity of bass via the volume, it's time to work on the quality of the bass with the CROSSOVER FREQUENCY control, PHASE control - and experiment with the sub room position.

- While playing music or a movie, move the subwoofer around, in and out of corners, closer and farther from the wall, etc. as much as the power cord and other connections will allow.

- Rotate the PHASE control between 0° - 180°, while someone sits in the main listening position. Leave the control in the position where you like the bass the most.

- Change the CROSSOVER FREQUENCY control (for Dolby Pro-Logic receivers) to higher and lower settings. If the CROSSOVER FREQUENCY control is set too high, you'll start to hear low midrange (voices and instruments) through it. This will negatively affect the stereo imaging of your main speakers. Lower the CROSSOVER FREQUENCY settings until you hear only bass from the subwoofer. If the CROSSOVER FREQUENCY control is set too low, you simply won't get much output from the subwoofer. Move it back closer to 80-100Hz.

8. After you are satisfied with the output of your Elura SUBR66-MINI, you can make all your volume settings through your main stereo system's volume control. The only time you might want to readjust the Elura SUBR66-MINI VOLUME is when you encounter a musical selection or movie that has abnormally low or high bass.

You can leave the Elura SUBR66-MINI turned on and in AUTO mode when not in use. It does not draw much power in this state and will be ready to add low bass the moment you begin to play music.

Remember, you don't have to do anything except leave the POWER switch ON and in the AUTO position. The Elura SUBR66-MINI will automatically go into STANDBY mode after approx 8 minutes, when no audio is playing.

If you're not using your system for a long period of time (such as when you're on vacation), turn the POWER switch to the OFF position.

## Caring for Your Elura SUBR66-MINI

The Elura SUBR66-MINI enclosure is finished in a very high-quality black gloss finish that is both attractive and excellent protection for the wood cabinet. To remove dust, finger prints, and light water marks you can use a soft, dry cloth. Never use a solvent like paint thinner, Ketone, gasoline, MEK, lighter fluid, etc., on the enclosure surface or it will cause permanent damage.

## F. SPECIFICATIONS

### Amplifier

Digital (Class D) with switching power supply, thermal protection, overload protection, soft clipping short circuit protection, high-efficiency, with low power consumption in standby mode.

### Power

400 watt RMS

### Input Connections

RCA L/R, LFE Line Level

### System Design

Passive Radiator

### Woofers

6" Hi-Excursion

2" (50mm) Voice-Coil, Glass Fiber & Paper compound cone with rubber surround

### Passive Radiator

6" Glass Fiber & Paper compound cone with rubber surround

### Frequency Response

40 - 280Hz Variable

### Crossover Control

40 - 120Hz Variable

### Controls

Power, Volume, Auto/On, Phase, Crossover Frequency

### Safety Rating

TuV

### Video-Shielded

No

### Dimensions (including feet)

10.7" H x 9" W x 9.5" D

(272mm H x 229mm W x 241mm D)

### Weight

19.8lbs (8.98kg)

### Finish

High Gloss Black

## G. TROUBLESHOOTING & SERVICE

Before returning your Elura SUBR66-MINI for service, you can save time by checking for a few problems that are most often encountered.

### Power light is not lit. No sound.

1. Is your subwoofer plugged in to a live AC wall socket?
2. Is the power switched on?
3. Has the subwoofer overheated and shut off temporarily?

### No sound from either set of speakers.

1. Are your other components turned on?
2. Is the receiver, preamp, or TV set to the appropriate input and is that sound source playing?
3. Do you have an unconnected tape monitor selected?
4. Is the subwoofer correctly connected to your receiver, preamplifier, integrated amplifier, or TV and turned on?

### Sound comes from main speakers but not the subwoofer.

1. Is the subwoofer turned on (power light in the green mode) and VOLUME control turned up?
2. Some digital receivers only send a sub out signal when in the movie or digital mode. In the 2-ch (stereo music) mode, no sub out signal is sent to the sub.

You may need to set your main speakers to small mode in your receiver setup to get the receiver's subwoofer output to turn on. Check your receiver's owner's manual for subwoofer operation.

3. For digital receivers - make sure the subwoofer is ON and the subwoofer level is set to 0dB or greater.

### Sound comes from the subwoofer but not the main speakers.

1. Confirm the power amplifier is turned on. Check the RCA patch cord. Check the speaker wire connections between the receiver and main or satellite speakers.

### Bass is muffled or weak.

1. Check speaker wire polarity of all connections.
2. Reposition your subwoofer. At some points in the room, its output may be cancelled by the geometry of the room. Moving the subwoofer can eliminate this problem. Please refer to Item 14 in the Safety Instructions for conditions that ALWAYS require service by qualified personnel.

If you have tried all the above and still can't get the SUBR66-MINI to operate properly, consult your dealer.

## H. PRODUCT WARRANTY

The SELLER warrants the SUBR66-MINI free from defects in the material and workmanship for 2 years from the date of purchase from the SELLER or an authorized dealer. Should this product fail to be in good working order within the warranty period, the SELLER, at its option repair or replace the unit, provided that the unit has not been subjected to accident, disaster, abuse, or any unauthorized modifications including static discharge and power surge. This warranty is offered by the SELLER for its BUYER with direct transaction only. This warranty does not apply to products that have been abused, incorrectly installed, modified, disassembled and/or repaired by anyone other than Elura or our appointed repair facility.

A unit that fails under conditions other than those covered will be repaired at the current price of parts and labor in effect at the time of repair. Such repairs are warranted for 90 days from the day of reshipment to the BUYER. If the unit is delivered by mail, customers agree to insure the unit or assume the risk of loss or damage in transit. Under no circumstances will a unit be accepted without a return authorization number.

The warranty is in lieu of all other warranties expressed or implied, including without limitations, any other implied warranty or fitness or merchantability for any particular purpose, all of which are expressly disclaimed.

Proof of sale may be required in order to claim warranty.

The content of this manual has been carefully checked and is believed to be accurate. However, the SELLER assumes no responsibility for any inaccuracies that may be contained in this manual. The SELLER will NOT be liable for direct, indirect, incidental, special, or consequential damages resulting from any defect or omission in this manual, even if advised of the possibility of such damages. Also, the technical information contained herein regarding the SUBR66-MINI features and specifications are subject to change without further notice.

[www.elura.audio](http://www.elura.audio)

