

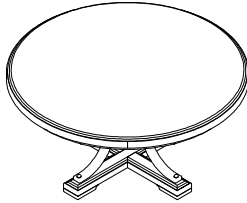

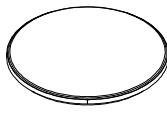

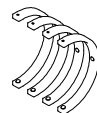

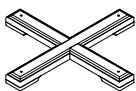

# HEKMAN®

**X** A HOWARD MILLER COMPANY  
 24802 ROUND COFFEE TABLE

## Part List

1	2	3	4	
TOP PANEL 1 Pc	METAL LEGS 4 Pcs	METAL RING 1 Pc	ASSEMBLY BASE 1 Pc	
				

## Hardware list

A	B	C	D	E	F
BOLT M6 x 15 4 PCS.	BOLT M6 x 40 4 PCS.	BOLT M6 x 60 4 PCS.	SPRING W. M6X13 12 PCS.	FLAT WASHER M6 X16 (12 PCS.)	ALLEN KEY L4 (FOR ALLEN BOLT) 1 PC.
					

## STEP 1

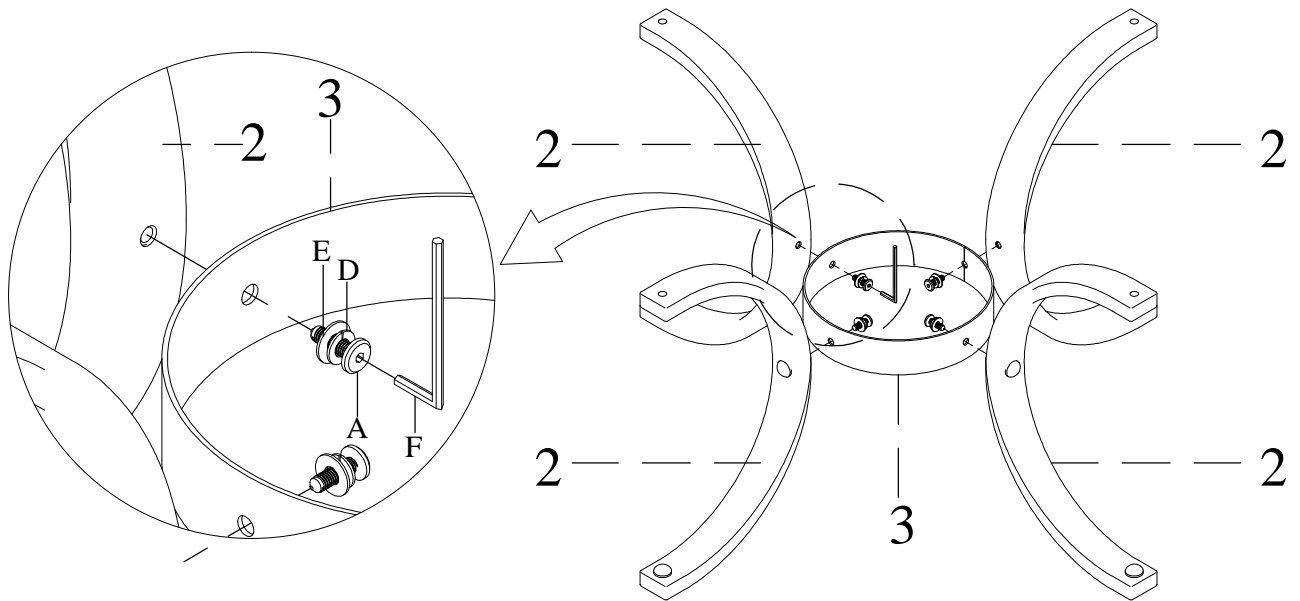

Joint 4 metal legs (2) with metal ring (3) using JCBC BOLT M6 x 15 Mm (A), Spring Washers (D), Flat Washer (E) & Allen key (F) (see detail) and do not tighten completely. Tighten after assembled with top and base Assemblies.

# HEKMAN®

**X** A HOWARD MILLER COMPANY

## 24802 ROUND COFFEE TABLE

### STEP 2

Lay the Top Assembly face down on a soft clean surface.

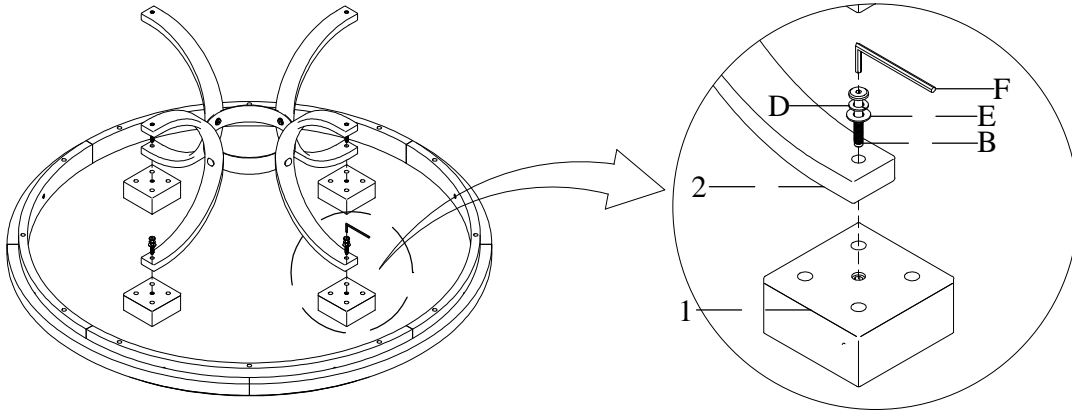

Assemble the Leg assembly to the top with JCBC bolt M6 x 40 Mm (B), Spring Washers (D), Flat Washer (E) & Allen key (F) (see detail). Do not tighten the bolts completely at this time.

### STEP 3

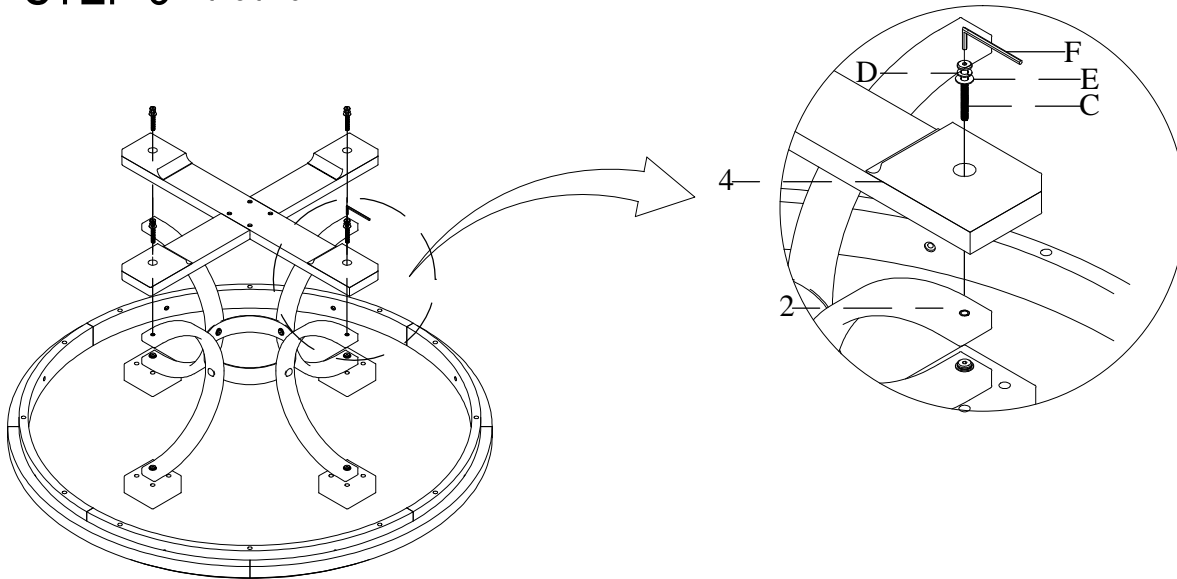

Attach the base assembly to the metal legs with JCBC BOLT M6 x 60 Mm (C), Spring Washers (D), Flat Washer (E) & Allen key (F) than tighten.  
Tighten all bolts completely

