

TIMELESS[®]

BY

minkaAire[®]
A Minka Group[®] Co.



ENERGY STAR

INSTRUCTION MANUAL WARRANTY CERTIFICATE

©2017 Minka Lighting Inc. Manual design and all elements of manual design are protected by United States Federal and/or State Law including Patents, Trademark, and/or Copyright Laws.



The Minka-Aire® warranty is for one (1) year from the date of purchase from an authorized Minka-Aire® dealer. This warranty is only valid to the original purchaser or user against all defects in material and workmanship (light bulbs excluded) for one (1) full year. Additionally, Minka-Aire® warrants the motor only for the lifetime of the Minka Aire ceiling fan (excluding wall controls and electrical components), to the original purchaser or user.

- * The warranty is voided with the use of any non- Minka-Aire® electrical devices, E.g., wall controls or electrical dimmer switches, etc...
- * The warranty is void once the original purchaser or user ceases to own the fan or the fan is moved from its original point of installation.
- * The warranty is void with the use of any hanger bracket (non-Minka Aire or non-fan specific) other than the hanger bracket supplied & installed with this specific fan.

Warranty Service Information

To obtain warranty service during the warranty period, the purchaser should return the fan with the sales receipt to the original place of purchase. The authorized Minka-Aire® dealer, at its sole discretion, will either repair or replace the fan after verifying the legitimacy of the warranty claim. Replacement is subject to availability of the same model. If the model is unavailable it will be replaced by one of equal value. This is a limited warranty; the original purchaser or user is responsible for the cost of removal and reinstallation of repaired or replacement product.

To obtain the name of the Minka-Aire® authorized dealer nearest you call the Minka-Aire® customer care department at 1-800-307-3267, or contact Minka-Aire® through www.minkagroup.net and select FAQ to answer any questions or if you require additional assistance submit the question form found there.

Date Purchased _____ Store Purchased _____ Model Number F614 Serial Number _____

SAFETY RULES.....	1	ATTACHING THE FAN BLADES.....	7
PACKAGE CONTENTS.....	2	ATTACHING THE SWITCH CUP.....	8
INSTALLING THE FAN.....	3	OPERATING YOUR FAN.....	9
HANGING THE FAN.....	4	CARE OF YOUR FAN.....	10
ELECTRICAL CONNECTIONS.....	5	TROUBLESHOOTING.....	11
FINISHING THE INSTALLATION.....	6	SPECIFICATIONS.....	12

CONTENTS



1151 W. Bradford Court, Corona, CA 92882 • For Customer Assistance Call: 1-800-307-3267



1

SAFETY RULES

1. Before you begin installing the fan, shut power off at the circuit breaker of the fuse box.
2. Be cautious! Read all instructions and safety information before installing your new fan. Review accompanying assembly diagrams.
3. Make sure that all electrical connections comply with local codes, ordinances, or National Electrical Codes. Hire a qualified electrician or consult a do-it-yourself wiring handbook if you are unfamiliar with installing electrical wiring.
4. Make sure the installation site you choose allows the fan blades to rotate without any obstructions. Allow a minimum clearance of 7 feet from the floor and 18 inches from the tip of the blades to the wall.
5. If you are mounting the fan to a ceiling fan outlet box, use a U.L. Listed metal octagonal outlet box marked "Acceptable for Fan Support". Secure the box directly to the building structure. The outlet box and its support must be able to support the moving weight of the fan (at least 50 pounds) Do not use a plastic box.
6. Caution: To reduce the risk of injury use only the screws provided with the outlet box in conjunction with the lock washers provided with the fan.
7. If you are mounting the fan to a joist, make sure it is able to support the moving weight of the fan (at least 50 pounds).
8. After you install the fan, make sure that all mounting components are secured to prevent the fan from falling.
9. Do not insert anything into the fan blades while the fan is operating.
10. Turn the fan off and wait for the blades to stop completely before performing any maintenance or cleaning.

NOTE: The important safeguards and instructions appearing in this manual are not meant to cover all possible conditions and situations that may occur. It must be understood that common sense, caution and care are factors which can not be built into this product. These factors must be supplied by the person (s) installing, caring for and operating the unit.

NOTE: READ AND SAVE ALL INSTRUCTIONS!

WARNING

TO REDUCE THE RISK OF FIRE, ELECTRIC SHOCK OR OTHER PERSONAL INJURY, MOUNT FAN ONLY TO A U.L. LISTED OUTLET BOX OR SUPPORTING SYSTEM MARKED ACCEPTABLE FOR FAN SUPPORT AND USE MOUNTING SCREWS PROVIDED WITH THE OUTLET BOX IN CONJUNCTION WITH THE LOCK WASHERS PROVIDED WITH THE FAN. MOST OUTLET BOXES COMMONLY USED FOR FAN SUPPORT OF LIGHTING FIXTURES ARE NOT ACCEPTABLE FOR FAN SUPPORT AND NEED TO BE REPLACED. CONSULT A QUALIFIED ELECTRICIAN IF IN DOUBT.

TO REDUCE THE RISK OF PERSONAL INJURY, DO NOT BEND THE BLADE HOLDERS WHILE INSTALLING, BALANCING THE BLADES OR CLEANING THE FAN. DO NOT INSERT FOREIGN OBJECTS BETWEEN ROTATING FAN BLADES.

TO REDUCE THE RISK OF FIRE OR ELECTRONIC SHOCK, DO NOT USE THIS FAN WITH ANY SOLID-STATE SPEED CONTROL DEVICE.

2

PACKAGE CONTENTS

Unpack your fan and check the contents. You should have the following items:

1. Fan blades (5)
 2. Hanger bracket, canopy and canopy cover assembly
 3. Downrod assembly
 4. Coupling cover
 5. Fan motor/housing assembly
 6. Blade holders (5)
 7. Switch cup plate
 8. Switch cup
 9. Balancing kit
- A. Mounting hardware:
 #10 x 1.5" Wood screws (2 PCs.)
 #8 x 3/4" Machine screws (2 PCs.)
 Lock washers (2 PCs.)
 4mm star washers (2 PCs.)
 Wire nuts (3 PCs.)
 Washers (2 PCs.)
 - B. Blade attachment hardware:
 3/16" x 7.5 mm screws (16 PCs.)
 Fiber washers (16 PCs.)
 - C. Bracket holder hardware:
 1/4" x 1/2" Screws with lock washers (11 PCs.)
 - D. Switch cup hardware
 Pull chain fob

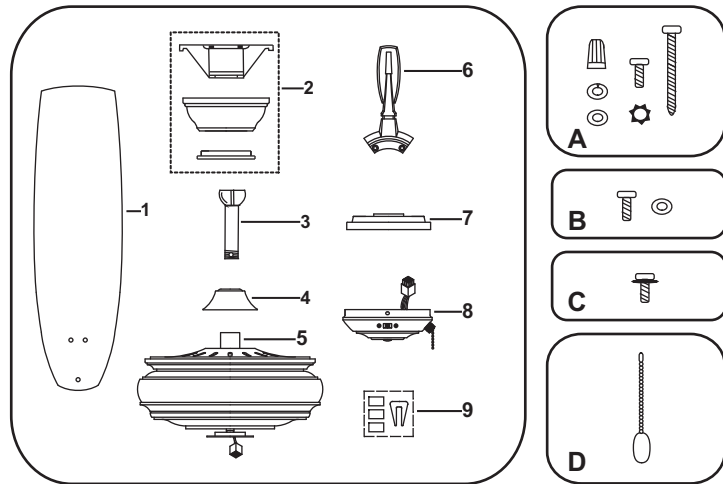

Tools Required: Phillips screw driver; slotted screw driver; step-ladder; wire cutters; electrical tape.

MOUNTING OPTIONS

If there isn't an existing mounting box, then read the following instructions. Disconnect the power by removing fuses or turning off circuit breakers.

Secure the outlet box directly to the building structure. Use appropriate fasteners and building materials. The outlet box and its support must be able to fully support the moving weight of the fan (at least 50 lbs.). Use a UL Listed metal outlet box. Do not use a plastic outlet box.

Figure 1, 2 and 3 are examples of different ways to mount the outlet box.

Note: You may need a longer downrod to maintain proper blade clearance when installing on a steep, sloped ceiling. Longer downrods are available from your Minka-Aire® dealer.

To hang your fan where there is an existing fixture but no ceiling joist, you may need to install a hanger bar as shown in Fig. 4 (available at your Minka-Aire® dealer).

INSTALLING THE FAN

3

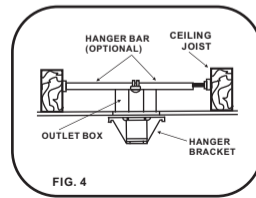
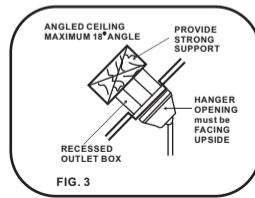
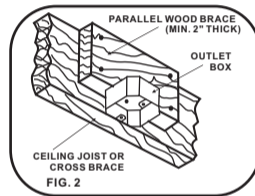
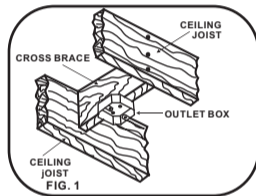

4

HANGING THE FAN

WARNING: All of the parts, hardware and components such as the hanger bracket and hanger ball have been provided for your safety and the proper installation of your new ceiling fan. The use of other parts, hardware or components not supplied by Minka Aire® with the fan will void the Minka Aire® Warranty.

REMEMBER to turn off the power. Follow the steps below to hang your fan properly:

Step 1. Remove the decorative canopy bottom cover from the canopy by turning the cover counter clockwise.(Fig. 5)

Step 2. Remove the hanger bracket from the canopy by loosening the one of two screws on the bottom of the hanging bracket a half turn from the screw head and turning the canopy counter clockwise.(Fig. 5)

Step 3. Secure the Hanger Bracket to the ceiling outlet box using the screws provided with your outlet box in conjunction with the lock-washers provided with the fan. (Fig. 6)

Step 4. Loosen the two Set Screws and remove the Hitch Pin and Lock Pin from the coupling located on the top of the Motor Assembly. (Fig. 7)

Step 5. Remove the Hanger Ball from the Downrod Assembly by loosening the Set Screw and removing the Cross Pin. (Fig. 8)

Step 6. Carefully feed fan wires up through the downrod. (Fig. 9) Thread Downrod into the Coupling until the holes are lined up and secure with the Lock Pin and Hitch Pin previously removed, tighten Set Screws. (Fig. 10)

Step 7. Slip Coupling Cover and Canopy onto Downrod. Carefully re-install the Hanger Ball onto the Downrod being sure that it's properly positioned over the Cross Pin and the wires are not twisted, tighten Set Screw. (Fig. 10)

Step 8. Lift the Motor Assembly and place the Hanger Ball into the Hanger Bracket. Rotate the Motor Assembly as needed until the check groove from the Hanger Ball rests firmly over the registration tab from the Hanger Bracket. Motor Assembly should not rotate if this is done correctly. (Fig. 11)

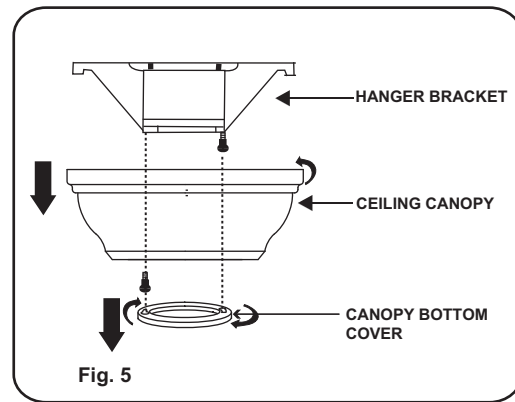

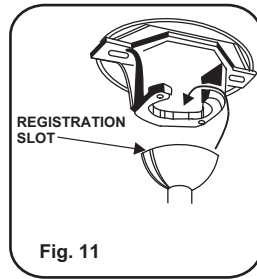
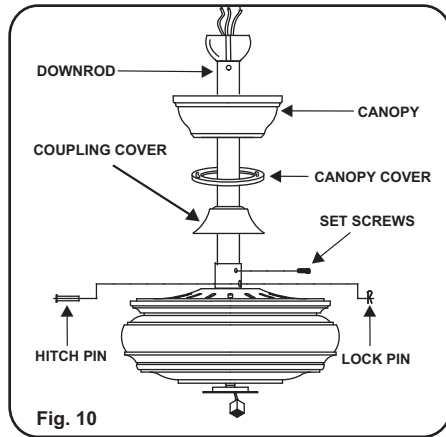
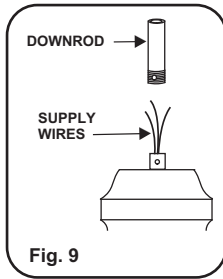
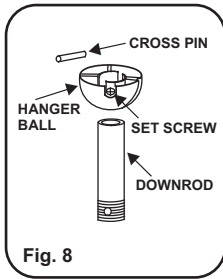
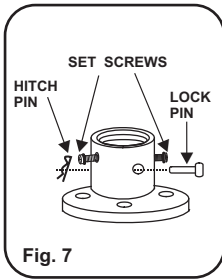
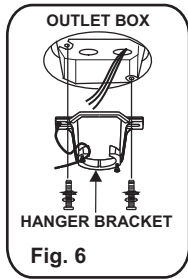

ELECTRICAL CONNECTIONS

REMEMBER to shut the power off at the circuit breaker or fuse box. Follow the steps below to connect the fan to your house supply wires. Use the wire nuts supplied with your fan. Secure the wire nuts by wrapping the connection with electrical tape.

Step 1. Connect the black (hot) wire from the ceiling to the black and the blue wires from the fan. Connect the white (Neutral) wire from the ceiling to the white wire from the fan. (Fig. 12)

Step 2. If your outlet has a ground wire (Green or Bare Copper) connect the fan ground wires (on hanger ball and hanger bracket) to it; otherwise connect the fan ground wire on hanger ball directly to the hanger bracket. (Fig. 11)

Step 3. Figure 13 & 14 illustrate the wiring connections using optional wall unit. (Available at your Minka-Aire® Retailer.) **NOTE:** If a light kit is not included with your fan, one can be purchased at your Minka-Aire® Retailer.

FAN CONTROLLED BY PULL CHAIN, LIGHT KIT CONTROLLED BY PULL CHAIN.

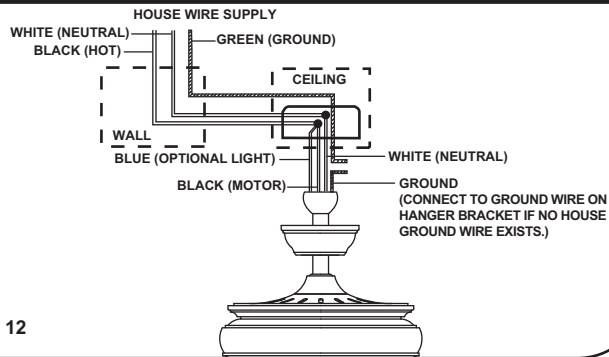

Fig. 12

FAN CONTROLLED BY PULL CHAIN, LIGHT KIT CONTROLLED BY WALL SWITCH.

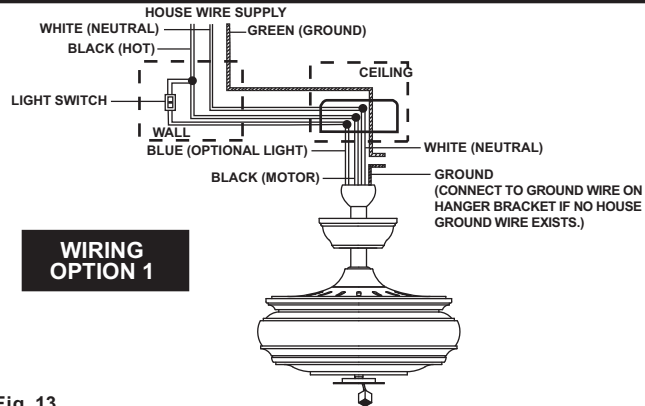

Fig. 13

FAN CONTROLLED BY WALL CONTROL, LIGHT KIT CONTROLLED BY LIGHT SWITCH.

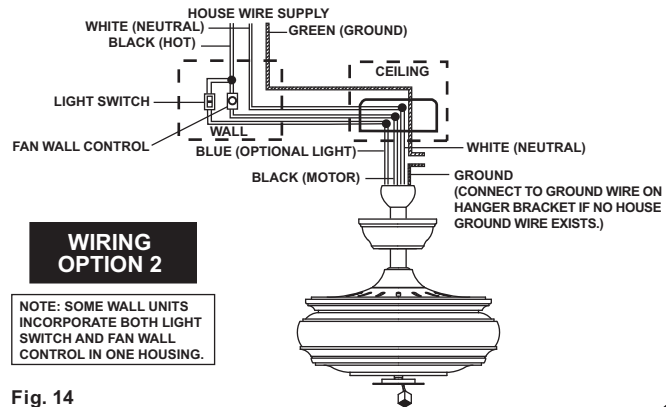

Fig. 14

FINISHING THE INSTALLATION

Step 1. Remove 1 of the 2 screws from the bottom of the hanger bracket and loosen the other one half a turn from the screw head.

Step 2. Slide the canopy up towards the hanger bracket and place the key hole on the canopy over the screw on the hanger bracket, turn canopy until it locks in place at the narrow section of the key holes. (Fig. 15)

Step 3. Align the circular hole on canopy with the remaining hole on the hanger bracket, secure by tightening the two set screws.

Note: Adjust the canopy screws as necessary until the canopy and canopy cover are snug.

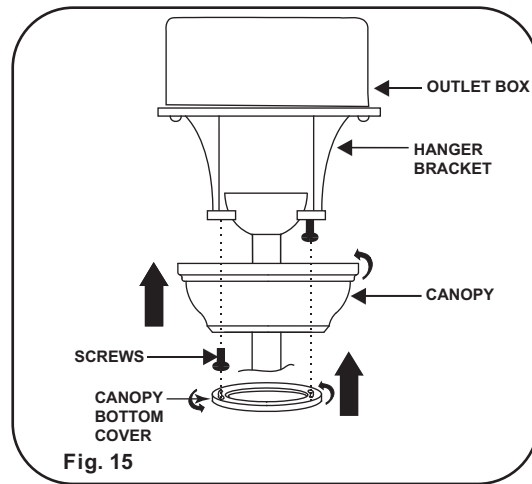

7

ATTACHING THE FAN BLADES

Step 1. Attach the fan blades to the blade holders using the screws and fiber washers provided, tighten screws securely. (Fig. 16)

Step 2. Remove rubber stops from motor. Rotate motor so that the screw holes are revealed through the opening on switch cap plate. Align motor holes to blade holders and secure with screws provided, tighten screws securely. (Fig. 17)

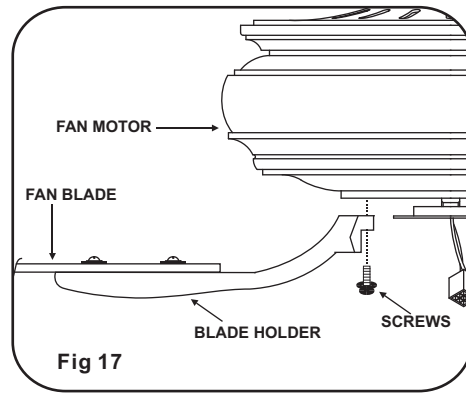
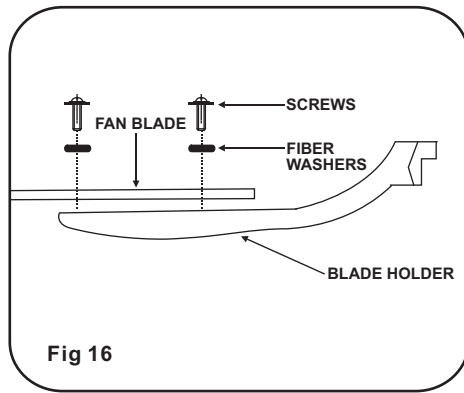

ATTACHING THE SWITCH CUP

Step 1. Remove the 1 of 3 screws from the mounting ring and loosen the other 2 screws. (Do not remove)

Step 2. Place the key holes on the switch cup plate over the 2 screws previously loosened from the mounting ring, turn switch cup plate until it locks in place at the narrow section of the key holes. Secure by tightening the 2 screws previously loosened and the one previously removed. (Fig. 18)

Step 3. Remove the screws from the switch cup plate. While holding the switch cup, firmly snap the wire molexes together. Next, slide switch cup up against plate and rotate it until the screw holes are aligned. Secure switch cup to plate using the screws removed earlier. (Fig. 19)

NOTE: DO NOT PINCH WIRES BETWEEN THE SWITCH CUP AND THE SWITCH CUP PLATE.

Step 4. Attach the pull chain fob to the chain on the switch cup.

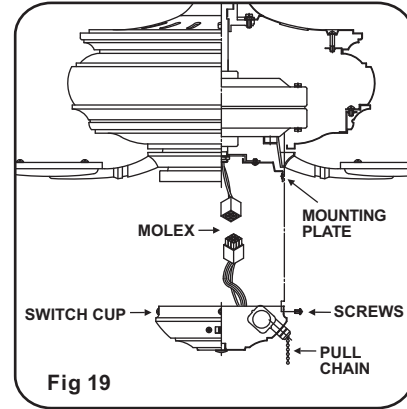
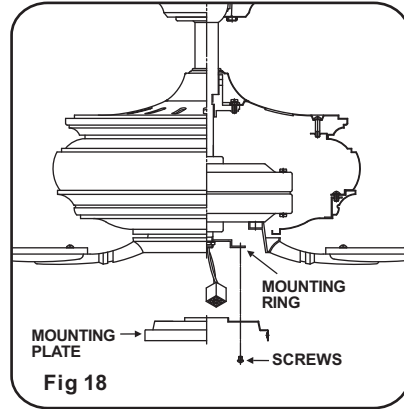

9

OPERATING YOUR FAN

Restore power to ceiling fan and test for proper operation.

Speed settings for warm or cool weather depend on factors such as the room size, Ceiling height, number of fans, etc.

The Reverse switch is located on the switch cup. Slide the switch to the Left for warm weather operation. Slide the switch to the Right for cool weather operation.

NOTE: Wait for fan to stop before changing the setting of the slide switch.

Warm weather - (Forward)

A downward airflow creates a cooling effect as shown in Fig. 20. This allows you to set your air conditioner on a warmer setting without affecting your comfort.

Cool weather - (Reverse)

An upward airflow moves warm air off the ceiling area as shown in Fig. 21. This allows you to set your heating unit on a cooler setting without affecting your comfort.

The pull chain controls the fan speed as follows: 1st pull - High, 2nd pull - Med, 3rd pull - Low and 4th pull - Off.

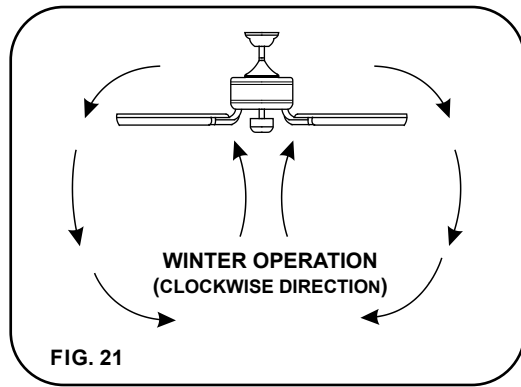
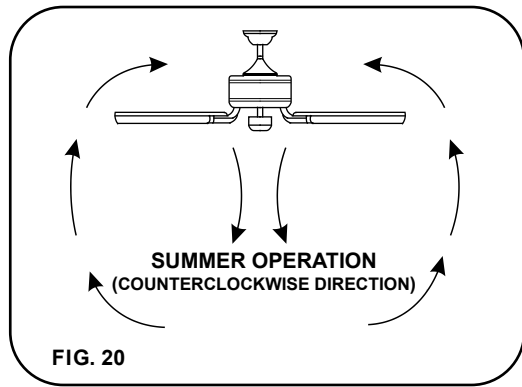

10

CARE OF YOUR FAN

Here are some suggestions to help maintain your fan.

1. Because of the fan's natural movement some connections may become loose. Check the support connections, brackets and blade attachments twice a year. Make sure they are secure. (It is not necessary to remove fan from the ceiling).

2. Clean your fan periodically to help maintain its new appearance over the years. Use only a soft brush or lint free cloth to avoid scratching the finish. Plated finishes are sealed with lacquer to minimize discoloration or tarnishing. Do not use water when cleaning, this could damage the motor, wood blades or possibly cause an electrical shock.

3. If your fan is provided with wood veneer blades; you can apply a light coat of furniture polish for additional protection and enhanced beauty. Cover small scratches with a light application of shoe polish.

4. Use a lint free lightly damp cloth or duster to remove dust from the blades.

5. There is no need to oil your fan. The motor has permanently lubricated bearings.

6. If your fan is provided with glass shades, clean with lukewarm soapy water and a soft cloth or sponge. **DO NOT IMMERSE GLASS SHADES IN HOT WATER. DO NOT PUT GLASS SHADES INTO AN AUTOMATIC DISHWASHER.**

WARNING!

MAKE SURE THE POWER IS OFF AT THE ELECTRICAL PANEL BOX BEFORE YOU ATTEMPT ANY REPAIRS. REFER TO THE SECTION, "ELECTRICAL CONNECTIONS".

SYMPTOM

Fan will not start

SOLUTION

- Check to make sure the wall switch is turned on.
- Check circuit fuses or breakers.
Caution! Make sure the power is turned off before performing the following steps.
- Remove canopy and check wire connections.
- If using a remote controlled fan; check to see that the deep switches from transmitter and receiver are set to the same frequency code.
- Check wall control transmitter connections (if applicable).
- Note: Fan must be installed from a maximum distance of 40 feet from the transmitting unit for proper signal transmission between the transmitting unit and the fan's receiving unit.

SYMPTOM

Fan will not start

SOLUTION

- Allow a 24-hour "break in" period. Most noises associated with a new fan will go away during this time.
- Make sure all blade attachment screws are tight.
- Make sure outlet box is secured to building structure, if necessary use the wood screws provided to further secure outlet box to joist.
- Make sure hanger bracket is secure to the outlet box, screws are tight.

TROUBLESHOOTING

SYMPTOM

Fan Wobble

SOLUTION

- NOTE: All blade sets are grouped by weight. Because wood and plastic blades vary in density, the fan may wobble even though blades are matched.
- Make sure all blade attachment screws are tight.
- Make sure outlet box is secured to building structure, if necessary use the wood screws provided to further secure outlet box to joist.
- Make sure hanger bracket is secure to the outlet box, screws are tight.
- If a Balancing kit is provided follow the instructions included with the balancing kit to help correct any excessive wobble.

12

SPECIFICATIONS

These are typical readings. Your actual fan may vary. They do not include amps and wattage used by the light (s).

Fan Size	Speed	Volts	Amps	Watts	RPM	N.W.	G.W.	C.F.
54"	Low	120	0.243	12	59	9.65	10.95	2.16'
	High	120	0.581	69	149	kgs	kgs	

PERFORMANCE AND ENERGY INFORMATION

ENERGYGUIDE

Estimated
Yearly Energy Cost
\$12

\$3 | | | **\$34**

Cost Range of Similar Models (19" – 84")

- Based on 12 cents per kWh and 6.4 hours use per day
- **Your cost depends on rates and use**
- Energy Use: 42 Watts

All estimates based on typical use, excluding lights

Airflow
3,261

Cubic Feet Per Minute

- The higher the airflow, the more air the fan will move
- Airflow Efficiency: 77 Cubic Feet Per Minute Per Watt

ftc.gov/energy

FAN SPEED	AIRFLOW (CFM)*	POWER USE (Watts)	AIRFLOW EFFICIENCY (CFM/Watt)
Low	1921	12	163
High	4491	69	65

Ceiling fan airflow is measured in cubic feet per minute (CFM).
Power use is measured in watts. To maximize energy savings:

- Choose a fan with high airflow efficiency (CFM/watt).
- Use ENERGY STAR® rated bulbs in your fan.
- Switch off your fan when you leave the room.

* Measure according to the DOE approved test method.

For any additional information about your
Minka Aire® Ceiling fan, please write to:

minkaAire
A Minka Group® Co

1151 W. Bradford Court, Corona, CA 92882
For Customer Assistance Call: 1-800-307-3267

