



MANUFACTURED BY:
Backyard Discovery
 3305 Airport Drive, Pittsburg, KS 66762
 800-856-4445

Basepoint Business Centre: Rivermead Drive, Westlea, Swindon SN5 7EX Phone: 0800-118-2476
 J.P. Coenstraat 7, The Bridge, The Hague, 2595 WP, Netherlands Phone: 0800-567-8990

HIGHLANDER

Swing Set

Model # 2106017

The assembly manual must be retained since it contains important information



WARNING

Adult Assembly Required.

Not suitable for children under 36 months due to small parts.

FOR DOMESTIC USE ONLY. INTENDED FOR OUTDOOR USE.



Please visit www.backyarddiscovery.com

For the most up to date assembly manual, to register your set, or to order replacement parts

Para obtener instrucciones en español, visite www.backyarddiscovery.com



EASY STEP-BY-STEP
3D INTERACTIVE INSTRUCTIONS

DOWNLOAD THE FREE APP



INSTALLATION SERVICES AVAILABLE!
See inside for details

Made in China
 INS-2106017-A-HIGHLANDER-ENG 03/18/22



Place the set on level ground, not less than 6'-7" [2 m] from any structure or obstruction such as a fence, garage, house, overhanging branches, laundry lines, or electrical wires.

- While assembling unit, take time before and after each phase to make sure fort is level. If fort is not level, assembly will be difficult and improper assembly may result. Extra care must be taken to insure the fort is square.
- The safe play area refers to a zone extending 6'-7" (2m) beyond the play product on all sides, including the space above the play product.

SAFE PLAY AREA DIAGRAM

Ground Dimension

15'-5" [4.7m] x 15'-6" [4.7m]

Safe Play Area

28'-7" [8.7m] x 28'-7" [8.7m]

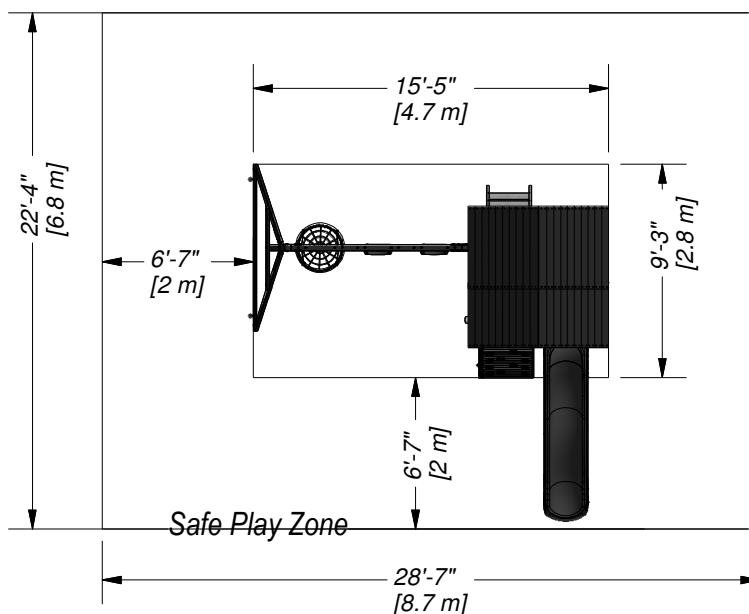

SAFE PLAY HEIGHT: 12'-9" [3.9 m]
MAXIMUM FALL HEIGHT: 7' [2.1 m]

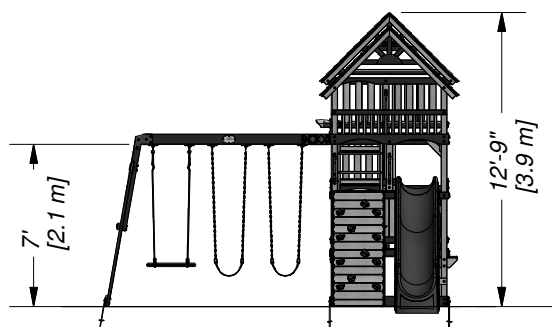

General Information:

Your set has been designed and engineered for children only and for residential use only.
 A maximum of 150 lbs. per child is recommended for play activities designed for individual use.
 A maximum of 120 lbs. per child is recommended for play activities designed for multiple child use.
 A maximum of 9 children is recommended for this swing set.



Wood Components (Not to Scale)



A1 | SWING BEAM - W4L13989
(x1) | 3 3/8"x5 1/4"x89 1/2" (86x134x2274)



A2 | SB 9" BLOCK - W4L13990
(x1) | 3 3/8"x5 1/4"x9" (86x134x228)

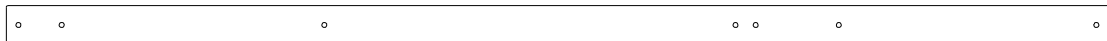

B01 | POST - W4L13900
(x1) | 3"x3"x86 7/8" (76x76x2207)



B02 | POST - W4L13915
(x1) | 3"x3"x86 7/8" (76x76x2207)

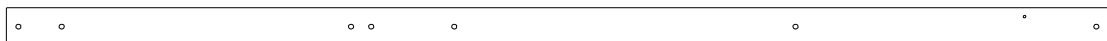

B03 | POST - W4L13902
(x1) | 3"x3"x86 7/8" (76x76x2207)



B04 | POST - W2A03074
(x1) | 3 1/16"x3"x86 7/8" (78x76x2207)

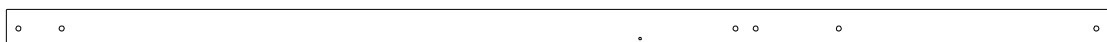

B05 | POST - W4L13986
(x1) | 3"x3"x86 7/8" (76x76x2207)



B06 | POST - W4L13987
(x1) | 3"x3"x86 7/8" (76x76x2207)

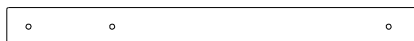

B07 | POST - W4L13903
(x1) | 3"x3"x32" (76x76x814)



B09 | POST - W4L13904
(x2) | 3"x3"x32" (76x76x814)

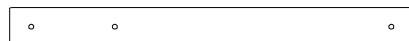

B08 | POST - W4L13975
(x1) | 3"x3"x32" (76x76x814)



B10 | POST - W4L13905
(x2) | 3"x3"x28 1/2" (76x76x724)



E01 | ANGLE BRACE - W4L13971
(x8) | 1 3/8"x3 3/8"x16 1/2" (36x86x420)



E02 | LADDER RAIL - W4L13970
(x3) | 1 3/8"x3 3/8"x32 3/4" (36x86x831)



E03 | LADDER RAIL - W4L13973
(x3) | 1 3/8"x3 3/8"x32 3/4" (36x86x831)



E04 | ROCK WALL RAIL - W4L13972
(x1) | 1 3/8"x3 3/8"x62" (36x86x1575)



E05 | ROCK WALL RAIL - W4L13976
(x1) | 1 3/8"x3 3/8"x63 5/8" (36x86x1575)



E07 | S.B. END SUPPORT - W4L13992
(x1) | 1 3/8"x3 3/8"x44 1/8" (36x86x1120)

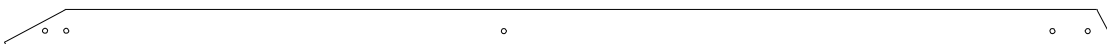

E06 | S.B. ANGLE BRACE - W4L13993
(x2) | 1 7/16"x3 3/8"x87 3/16" (36x86x2214)



Wood Components (Not to Scale)



F01 | TELESCOPE MOUNT - W4L13974
(x1) | 1 3/8"x2 3/8"x5 1/4" (36x60x134)

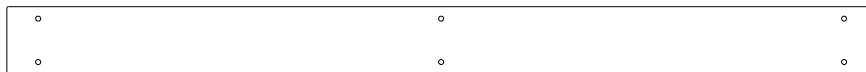

G01 | GROUND BOARD - W4L13907
(x1) | 1"x5 1/4"x67 7/8" (24x134x1724)



G02 | GROUND BOARD - W4L13984
(x1) | 1"x5 1/4"x86 1/8" (24x134x2187)



G03 | GROUND BOARD - W4L13911
(x2) | 1"x5 1/4"x60" (24x134x1524)



G04 | GROUND BOARD - W4L13982
(x1) | 1"x5 1/4"x60" (24x134x1524)



G05 | WALL RAIL - W4L13910
(x1) | 1"x5 1/4"x60" (24x134x1524)

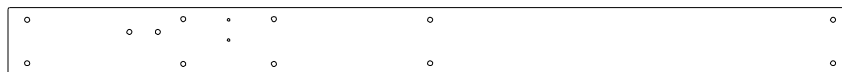

G06 | FLOOR RAIL - W4L13908
(x1) | 1"x5 1/4"x66" (24x134x1676)

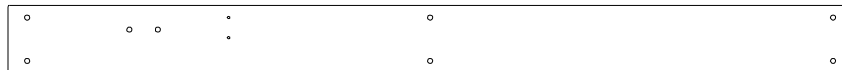

G07 | FLOOR RAIL - W4L13953
(x1) | 1"x5 1/4"x66" (24x134x1676)



G08 | FLOOR RAIL - W4L13912
(x1) | 1"x5 1/4"x61 7/8" (24x134x1572)



G09 | WALL RAIL - W4L13909
(x1) | 1"x5 1/4"x61 7/8" (24x134x1572)

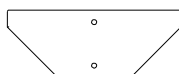

G10 | PICNIC TABLE SUPPORT - W4L13938
(x2) | 1"x5 1/4"x13 1/2" (24x134x344)



G11 | GROUND BOARD - W4L13991
(x1) | 1"x5 1/4"x86 3/4" (24x134x2202)



Wood Components (Not to Scale)



H01 | RAIL - W4L13926
(x1) | 1"x3 3/8"x61 7/8" (24x86x1572)

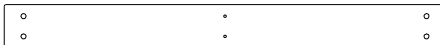

H02 | RAIL - W4L13985
(x2) | 1"x3 3/8"x34 1/2" (24x86x876)



H03 | RAIL - W4L13927
(x1) | 1"x3 3/8"x61 7/8" (24x86x1572)



H04 | RAIL - W4L13928
(x3) | 1"x3 3/8"x60" (24x86x1524)

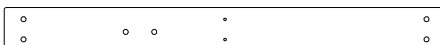

H05 | RAIL - W4L13932
(x2) | 1"x3 3/8"x34 1/2" (24x86x876)



H06 | RAIL - W4L13983
(x1) | 1"x3 3/8"x60" (24x86x1524)



H07 | RAIL - W4L13925
(x1) | 1"x3 3/8"x61 7/8" (24x86x1572)



H08 | RAIL - W4L13924
(x1) | 1"x3 3/8"x61 1/4" (24x86x1556)



H09 | LADDER RUNG - W4L13939
(x6) | 1"x3 3/8"x22" (24x86x560)



H10 | RAIL - W4L13934
(x1) | 1"x3 3/8"x32 3/4" (24x86x833)



H11 | RAIL - W4L13937
(x1) | 1"x3 3/8"x26 7/8" (24x86x681)



H12 | BENCH - W4L13933
(x2) | 1"x3 3/8"x32 1/2" (24x86x824)

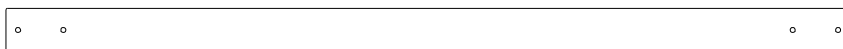

H13 | RAIL - W4L13923
(x1) | 1"x3 3/8"x66" (24x86x1676)

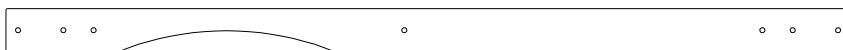

H14 | RAIL - W4L13922
(x1) | 1"x3 3/8"x66" (24x86x1676)

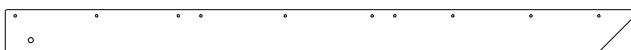

H15 | RAFTER - W4L13929
(x4) | 1"x3 3/8"x49 3/4" (24x86x1262)



Wood Components (Not to Scale)



H16 | RAFTER - W4L13931
(x2) | 1"x3 3/8"x49 7/8" (24x86x1268)



H17 | RAFTER - W4L13930
(x2) | 1"x3 3/8"x49 7/8" (24x86x1268)



H18 | RAIL - W4L13935
(x1) | 1"x3 3/8"x28 3/4" (24x86x731)



H19 | PICNIC TABLE SEAT - W4L13940
(x2) | 1"x3 3/8"x14 3/4" (24x86x374)



H20 | PICNIC TABLE SEAT SUPPORT - W4L13941
(x2) | 1"x3 3/8"x14 1/2" (24x86x368)



K01 | SUNBURST - W4L13914
(x2) | 5/8"x5 1/4"x13 1/2" (16x134x344)



L1 | ROCK WALL BOARD - W4L13916
(x4) | 5/8"x4 3/8"x26 1/4" (16x112x668)

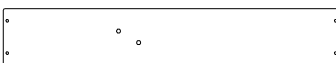

L2 | ROCK WALL BOARD - W4L13917
(x4) | 5/8"x4 3/8"x26 1/4" (16x112x668)



L3 | ROCK WALL BOARD - W4L13918
(x5) | 5/8"x4 3/8"x26 1/4" (16x112x668)



M01 | WALL RAIL - W4L13947
(x11) | 5/8"x3 3/8"x34 1/2" (16x86x876)



M02 | WALL RAIL - W4L13943
(x2) | 5/8"x3 3/8"x61 1/4" (16x86x1556)

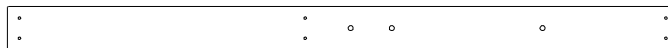

M03 | WALL BOARD - W4L13944
(x1) | 5/8"x3 3/8"x52 3/8" (16x86x1332)



M04 | WALL RAIL - W4L13946
(x2) | 5/8"x3 3/8"x34 1/8" (16x86x868)

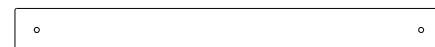

M05 | WALL RAIL - W4L13949
(x1) | 5/8"x3 3/8"x33 1/4" (16x86x844)



M06 | WALL BOARD - W4L13952
(x40) | 5/8"x3 3/8"x23 1/4" (16x86x591)



M07 | WALL BOARD - W4L13951
(x12) | 5/8"x3 3/8"x26 5/8" (16x86x677)

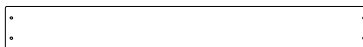

M08 | PICNIC TABLE - W4L13950
(x4) | 5/8"x3 3/8"x28 1/2" (16x86x724)



M09 | ROCK WALL BOARD - W4L13920
(x1) | 5/8"x3 3/8"x26 1/4" (16x86x668)



M10 | ROCK WALL BOARD - W4L13948
(x1) | 5/8"x3 3/8"x27 5/8" (16x86x702)



Wood Components (Not to Scale)



N01 | WALL RAIL - W4L13954
(x2) | 5/8"x2 3/8"x55" (16x60x1398)



N02 | LADDER BACK - W4L13960
(x6) | 5/8"x2 3/8"x23 1/2" (16x60x596)



N03 | GABLE BOARD - W4L13956
(x2) | 5/8"x2 3/8"x34" (16x60x864)

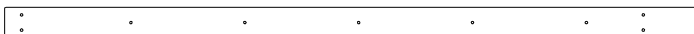

N04 | ROCKWALL CLEAT - W4L13955
(x1) | 5/8"x2 3/8"x54 1/2" (16x60x1385)

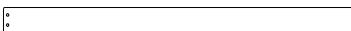

N05 | ROCK WALL BOARD - W4L13958
(x1) | 5/8"x2 3/8"x27 5/8" (16x60x702)

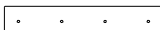

N06 | PICNIC TABLE SUPPORT - W4L13959
(x1) | 5/8"x2 3/8"x12 3/8" (16x60x314)



N07 | UPPER WALL RAIL - W4L13919
(x1) | 5/8"x2 3/8"x60" (16x60x1524)

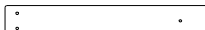

N08 | GABLE BOARD - W4L13961
(x2) | 5/8"x2 3/8"x16" (16x60x406)



N09 | GABLE BOARD - W4L13962
(x4) | 5/8"x2 3/8"x10" (16x60x254)



N10 | GABLE BOARD - W4L13963
(x2) | 5/8"x2 3/8"x3" (16x60x76)



O2 | WALL BOARD - W4L13921
(x14) | 5/8"x1 3/8"x14" (16x36x356)



O70 | SLIDE MOUNTING BOARD - W4L09040
(x1) | 5/8"x1 3/8"x20 3/8" (16x34x517)

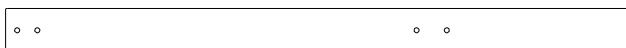

SP1 | SWING BEAM SUPPORT - W4L13988
(x1) | 3 3/8"x3 3/8"x49 3/8" (86x86x1254)



Wood Components (Not to Scale)



HH1 | FLOOR PANEL - W2A03079
(x2) | 1 1/4"x20 1/8"x36 3/8" (32x510x924)



HH4 | FLOOR PANEL - W2A03075
(x1) | 32 7/16"x1 1/4"x21 1/8" (824x32x536)

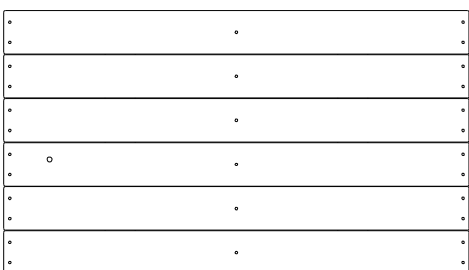

HH2 | FLOOR PANEL - W2A03080
(x1) | 36 3/8"x1 1/4"x20 9/16" (924x32x522)



HH5 | FLOOR PANEL - W2A03076
(x1) | 1 1/4"x20 9/16"x32 7/16" (32x522x824)

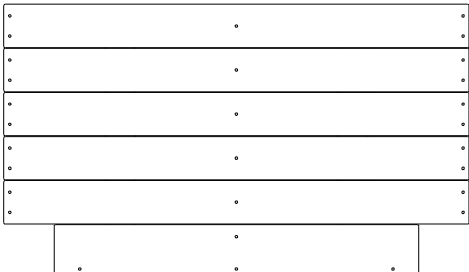

HH3 | FLOOR PANEL - W2A03078
(x2) | 36 3/8"x1 1/4"x21 1/8" (924x32x536)

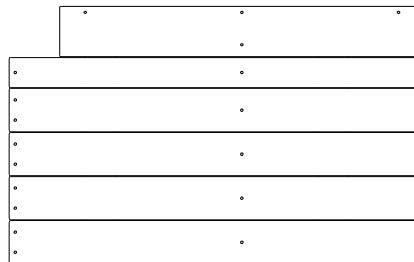

HH6 | FLOOR PANEL - W2A03077
(x1) | 1 1/4"x20 1/8"x32 7/16" (32x510x824)



HH7 | FLOOR PANEL - W2A03087
(x1) | 36 3/8"x1 1/4"x20 9/16" (924x32x522)



Wood Components (Not to Scale)

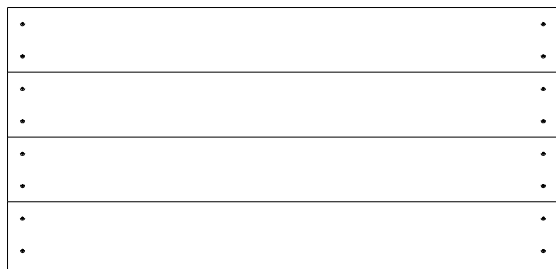

RP1 | ROOF PANEL - W2A03081
(x2) | 1 5/8"x20 11/16"x43 1/16" (42x526x1094)

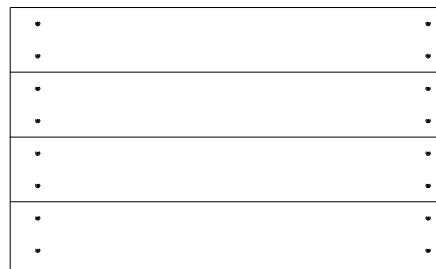

RP4 | ROOF PANEL - W2A03083
(x1) | 33 7/8"x1 5/8"x20 11/16" (860x42x526)

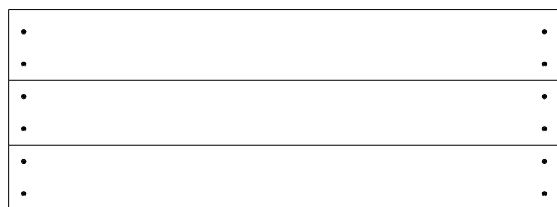

RP2 | ROOF PANEL - W2A03082
(x2) | 1 5/8"x15 5/8"x43 1/16" (41x397x1094)

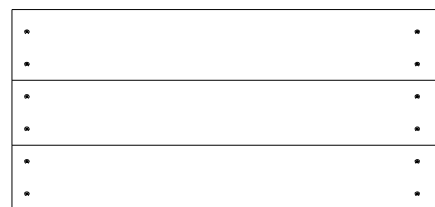

RP5 | ROOF PANEL - W2A03084
(x1) | 1 5/8"x15 5/8"x33 7/8" (42x397x860)



RP3 | ROOF PANEL - W2A03135
(x2) | 1 5/8"x15 5/8"x43 1/16" (41x397x1094)

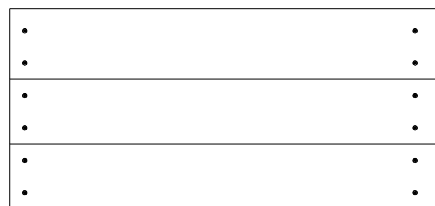

RP6 | ROOF PANEL - W2A03072
(x1) | 1 5/8"x15 5/8"x33 7/8" (42x397x860)

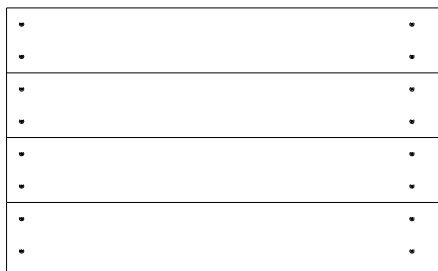

RP7 | ROOF PANEL - W2A03085
(x1) | 1 5/8"x20 11/16"x33 7/8" (42x526x860)

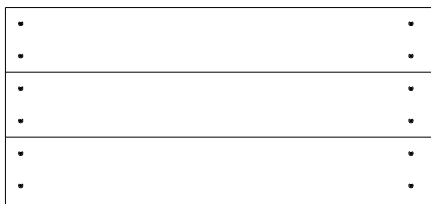

RP8 | ROOF PANEL - W2A03086
(x1) | 1 5/8"x15 5/8"x33 7/8" (42x397x860)

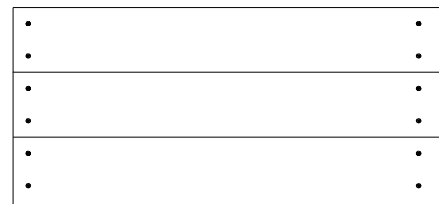

RP9 | ROOF PANEL - W2A03073
(x1) | 1 5/8"x15 5/8"x33 7/8" (42x397x860)



Hardware Components



H100415 | BOLT WH BLK
(x88) | 5/16x3 3/4

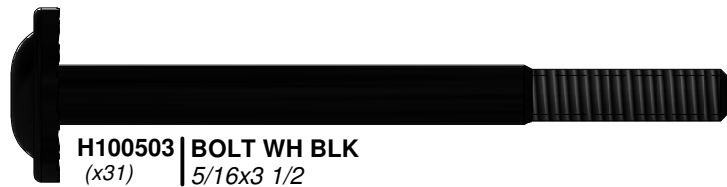

H100503 | BOLT WH BLK
(x31) | 5/16x3 1/2

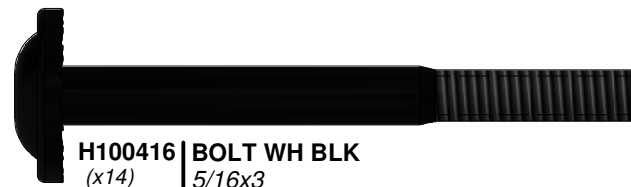

H100416 | BOLT WH BLK
(x14) | 5/16x3



H100205 | BOLT WH BLK
(x20) | 5/16x2-1/4



H100457 | BOLT WH BLK
(x4) | 5/16x2

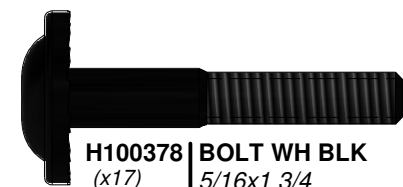

H100378 | BOLT WH BLK
(x17) | 5/16x1 3/4



H100407 | BOLT WH BLK
(x4) | 5/16x1 1/2



H100459 | BOLT WH BLK
(x4) | 5/16x1 1/4

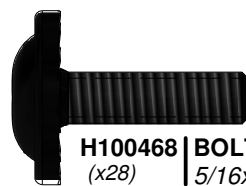

H100468 | BOLT WH BLK
(x28) | 5/16x1

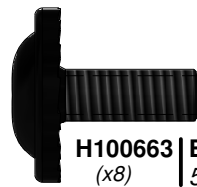

H100663 | BOLT WH BLK
(x8) | 5/16x3/4

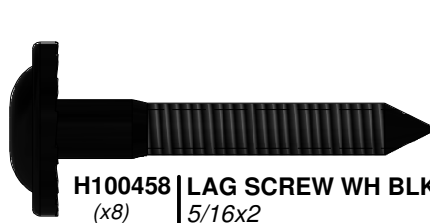

H100458 | LAG SCREW WH BLK
(x8) | 5/16x2

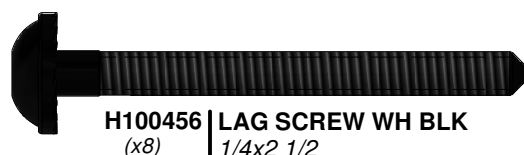

H100456 | LAG SCREW WH BLK
(x8) | 1/4x2 1/2



H100481 | BOLT HEX BLK
(x4) | 5/16x1 1/4



H100489 | BOLT PTH BLK
(x24) | 1/4x3/4



H100832 | BOLT PTH
(x4) | 1/4x3/4 BLK (with
LOCTITE)

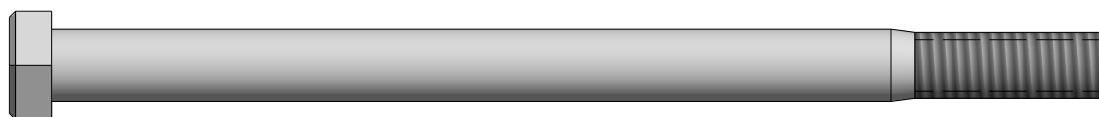

H100654 | BOLT HEX
(x12) | 3/8x5-1/2



Hardware Components



H100201 | SCREW PFH BLK
(x12) | 8x2-1/2



H100483 | SCREW PFH BLK
(x2) | 8x2 1/4



H100380 | SCREW PFH BLK
(x30) | 8x1 1/8



H100202 | SCREW PWH BLK
(x6) | 8x5/8



H100111 | SCREW PFH
(x116) | 8x2



H100089 | SCREW PFH
(x24) | 8x1 3/4



H100086 | SCREW PFH
(x322) | 8x1 1/2



H100087 | SCREW PFH
(x8) | 8x1 1/4



H100088 | SCREW PFH
(x259) | 8x1 1/8



H100199 | WASHER LOCK EXT BLK
(x29) | 12x19



H100405 | WASHER LOCK EXT BLK
(x8) | 6x15



H100473 | WASHER LOCK INT BLK
(x24) | 8x15



H100193 | NUT BARREL WH BLK
(x2) | 5/16x1-1/2



H100192 | NUT BARREL WH BLK
(x31) | 5/16x7/8



H100469 | NUT BARREL WH BLK
(x9) | 5/16x5/8



H100831 | NUT BARREL PTH BLK
(x4) | 1/4x3/4

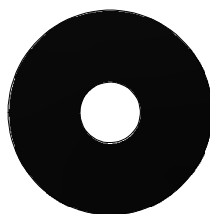

H100478 | WASHER FLAT BLK
(x4) | 8x27



H100198 | WASHER LOCK EXT BLK
(x165) | 8x19



H100477 | WASHER SPLIT BLK
(x4) | 5/16



H100379 | T-NUT BLK
(x183) | 5/16



H100398 | T-NUT BLK
(x24) | 1/4

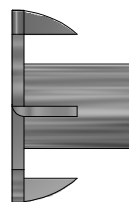

H100073 | T-NUT
(x12) | 3/8

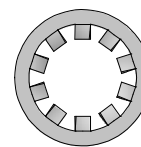

H100107 | WASHER LOCK INT
(x12) | 10x18

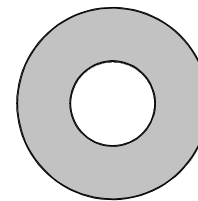

H100102 | WASHER FLAT
(x12) | 11x25



Hardware Components

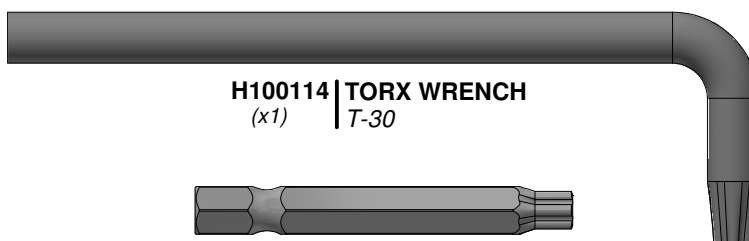

H100114 | TORX WRENCH
(x1) | T-30



H100147 | TORX BIT
(x1) | T-30



H100764 | SCREW SETTER
(x1)

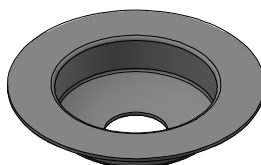

H100225 | FLANGE CUP WASHER
(x1) | 9x34



H100082 | SCREW TAPPING
(x1) | 14x2 1/2

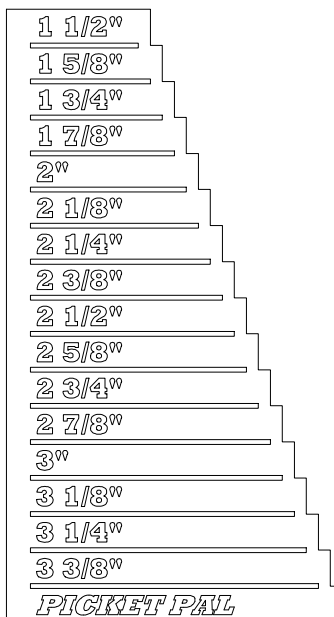

A6P00410 | PICKET PAL
(x1)

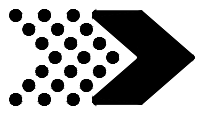

Accessory Components (Not to Scale)



A100164 (x1) | BYD ID TAG (LARGE) AGES 3-10



A6P00037 (x8) | GREEN HC ROCK #2



A6P00036 (x4) | GREEN HC ROCK #1

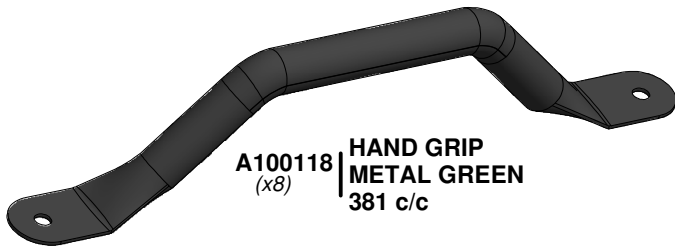

A100118 (x8) | HAND GRIP METAL GREEN 381 c/c



A100107 (x1) | STEERING WHEEL



A4M01047 (x9) | L BRACKET 2.5x38x55x55

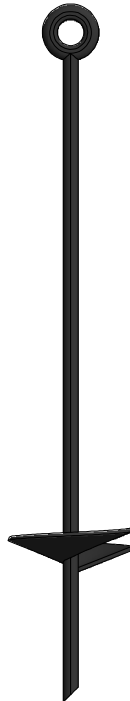

A100178 (x6) | AUGER GROUND STAKE

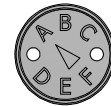

A100314 (x1) | "A" REVISION TAG

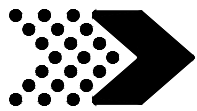

Accessory Components (Not to Scale)

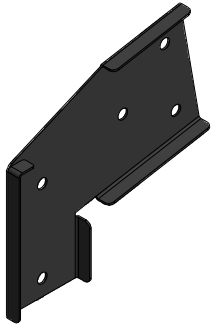

A100325 | SWING BEAM
(x1) | EXTENSION
BRACKET-LEFT

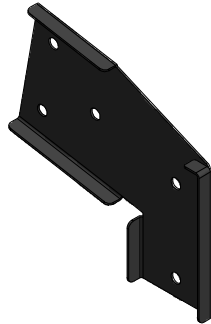

A100326 | SWING BEAM
(x1) | EXTENSION
BRACKET-RIGHT

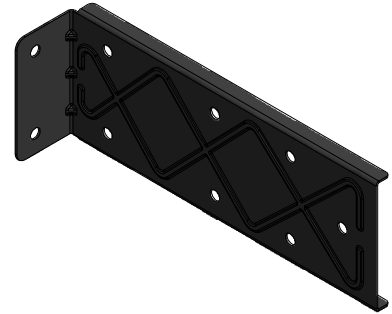

A4M00993 | EXTENDED
(x2) | SWING BEAM
BRACKET

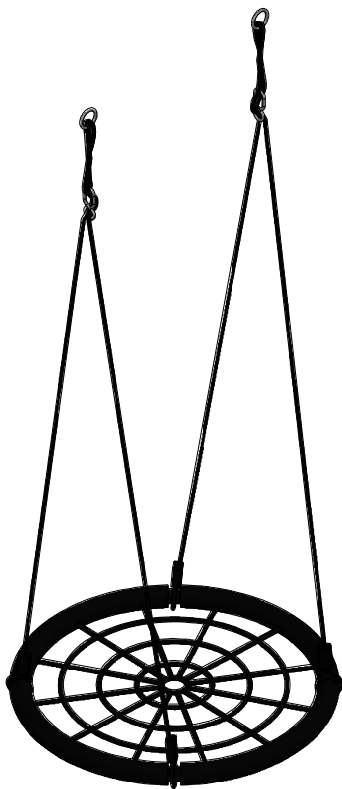

A4M01126 | 26" WEB SWING SEAT ROPE
(x1)

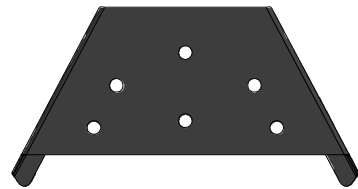

A4M01169 | A-FRAME BRACKET
(x1)

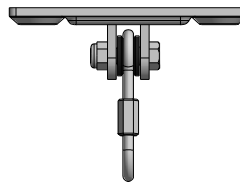

A4M00505 | SWING HANGER
(x6)



A100069 | QUICK LINK
(x4)



A6P00054 | SWING SEAT GREEN 22"
(x2)



A100047 | CHAIN GREEN 57"
(x4)

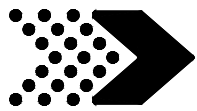

Accessory Components (Not to Scale)

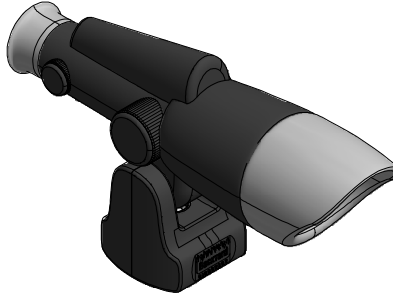

A100104 | TELESCOPE KIT
(x1)



A100287 | SLIDE VF 10 FT
(x1)

PRE-ASSEMBLY STEP 1 - SORTING PARTS

It is critical for ease of assembly that you take the time to sort and organize the wood and hardware.

WOOD PARTS:

- Organize wood parts by the three-digit, alpha-numeric number stamped on each board (ex. P01).
- If there are multiple boards with the same stamped number, stack those pieces together.
- Stamps can be found on the flat surface of the boards or on the end of the boards.
- Allow yourself plenty of room - the wood pieces can take up a significant amount of space.

NOTE: CARTONS ARE NOT ORGANIZED BY BOARD NUMBER.

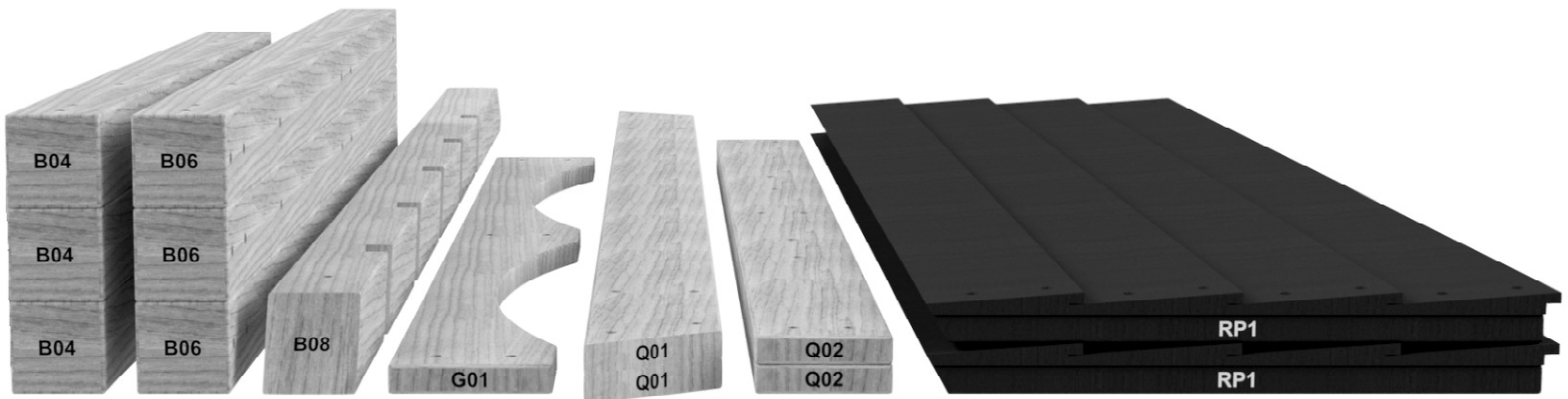

HARDWARE PARTS:

- We recommend that you have a separate table to organize the hardware.
- Hardware bags are printed with a seven-digit, alpha-numeric part number.
- You can organize your hardware by part number or group by hardware type (i.e. bolts, nuts, etc.).
- During assembly you only need to reference the last four digits of the number.

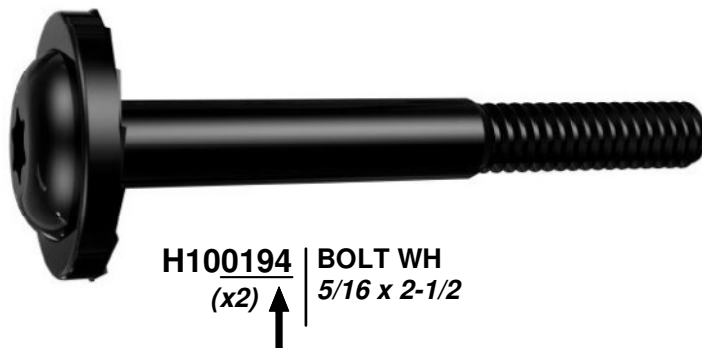

PRE-ASSEMBLY STEP 2 - TOOLS REQUIRED



Cordless Drill or
Electric Drill



Drill Attachments:
Phillips Head



1/8", 3/16", 3/8" & 7/16"
Drill Bits



Phillips Screw Driver



Open End Wrenches 1/2" & 9/16"



3/8" Drive Ratchet, 1/2" &
9/16" STD Sockets 1/2" & 9/16"
Deep Sockets



Claw Hammer



Rubber Mallet - Optional

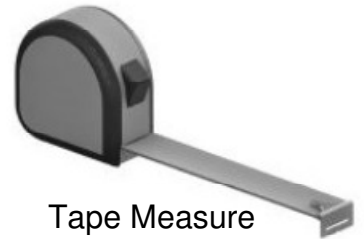

Tape Measure

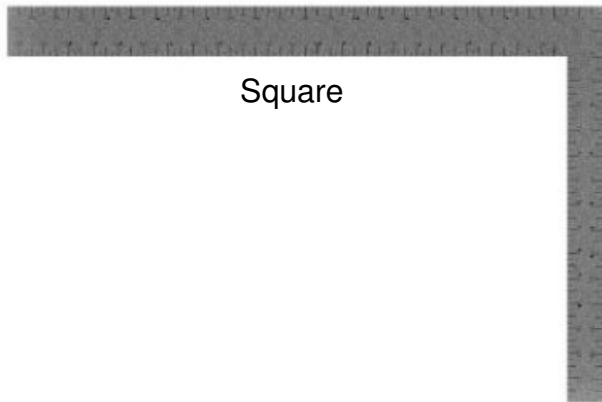

Square





Level 24"

PRE-ASSEMBLY STEP 3 - CHOOSE YOUR ASSEMBLY METHOD



There are several types of assembly instructions available to you.

1. Printed Assembly Manual included with your set
2. BILT APP - 3D interactive instructions
3. Combination of the Printed Manual and BILT APP (Note: Step numbers can differ between the two methods)

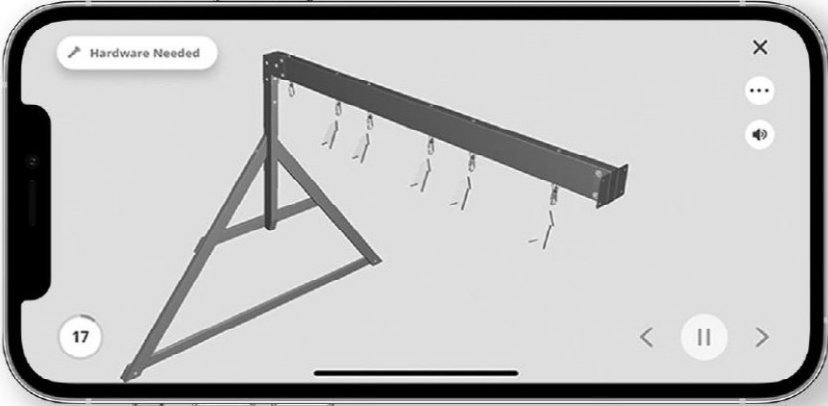

Scan for easy 3D instructions

Download the BILT app
before you begin



The image shows a smartphone screen displaying the BILT app interface. The screen features a 3D assembly diagram of a metal frame with a horizontal beam and several hanging components. The interface includes a 'Hardware Needed' button at the top left, a close button (X) at the top right, a menu button (three dots) and a volume icon below it, and a page number '17' in a circle at the bottom left. At the bottom center, there are navigation arrows and a pause button.

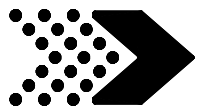

LADDER ASSEMBLY

STEP 1

E02 | LADDER RAIL - W4L13970
(x3) | 1 3/8"x3 3/8"x32 3/4" (36x86x831)

E03 | LADDER RAIL - W4L13973
(x3) | 1 3/8"x3 3/8"x32 3/4" (36x86x831)

H09 | LADDER RUNG - W4L13939
(x6) | 1"x3 3/8"x22" (24x86x560)

H100111 | SCREW PFH
(x24) | 8x2



TIP:
LAY PARTS ON GROUND OR SAW
HORSES FOR EASE OF ASSEMBLY.

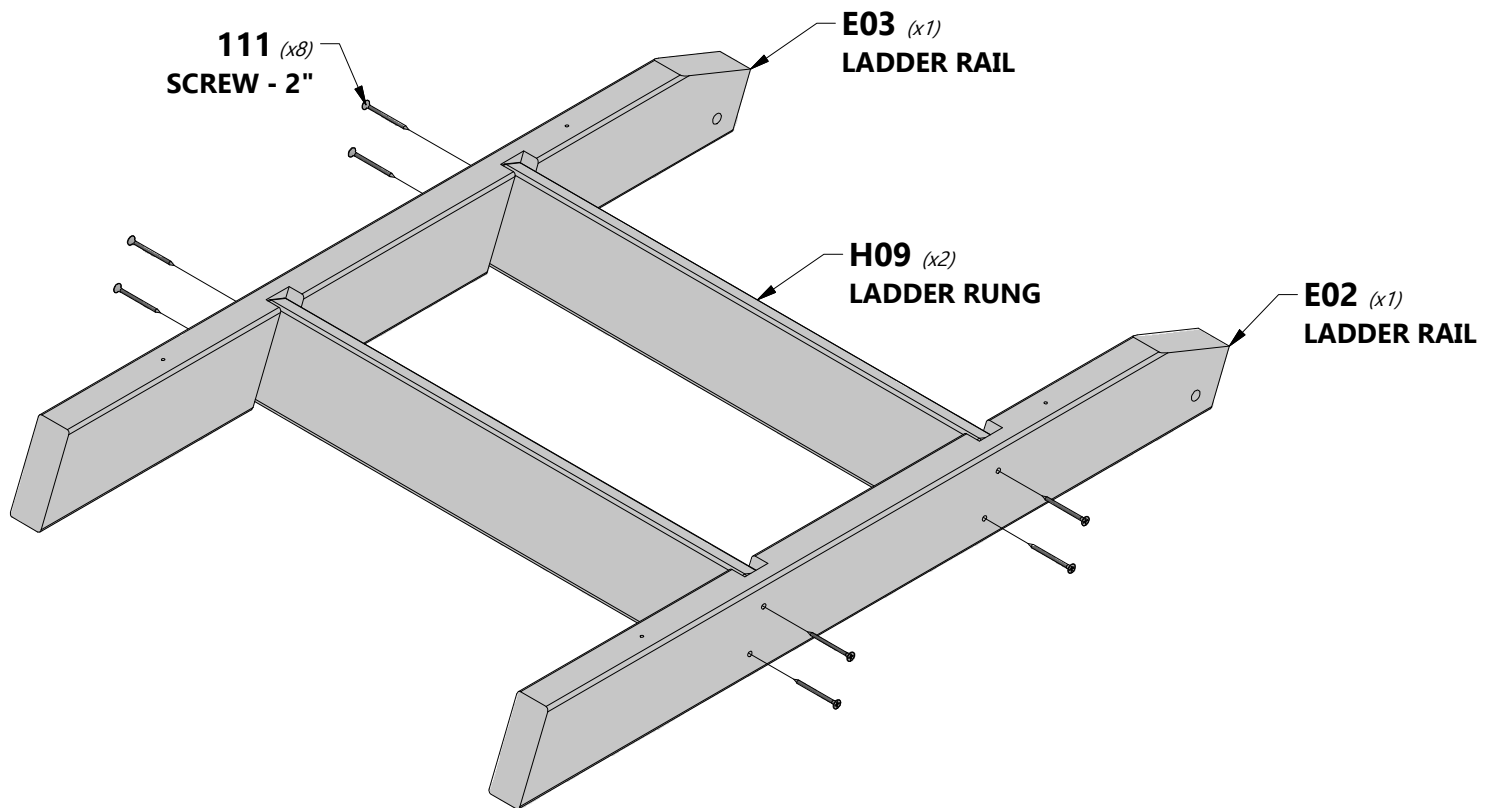

REPEAT THIS STEP TO COMPLETE THREE LADDER ASSEMBLIES

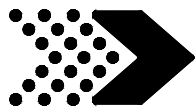

N02 | LADDER BACK - W4L13960
(x6) | 5/8"x2 3/8"x23 1/2" (16x60x596)

H100111 | SCREW PFH
(x12) | 8x2

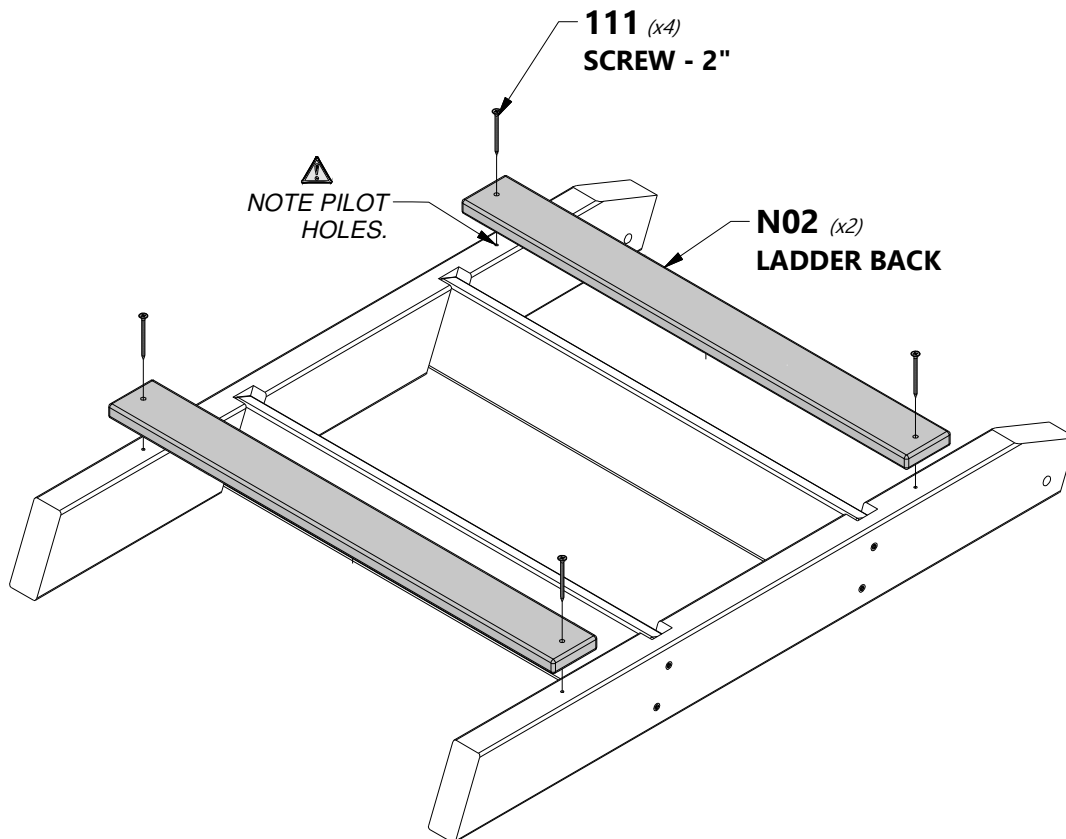

REPEAT THIS STEP TO COMPLETE THREE LADDER ASSEMBLIES



LADDER ASSEMBLY

STEP 3



A4M01047 | L BRACKET
(x6) | 2.5x38x55x55



H100468 | BOLT WH BLK
(x6) | 5/16x1



H100192 | NUT BARREL WH BLK
(x6) | 5/16x7/8



H100199 | WASHER LOCK
(x6) | EXT 12x19 BLK

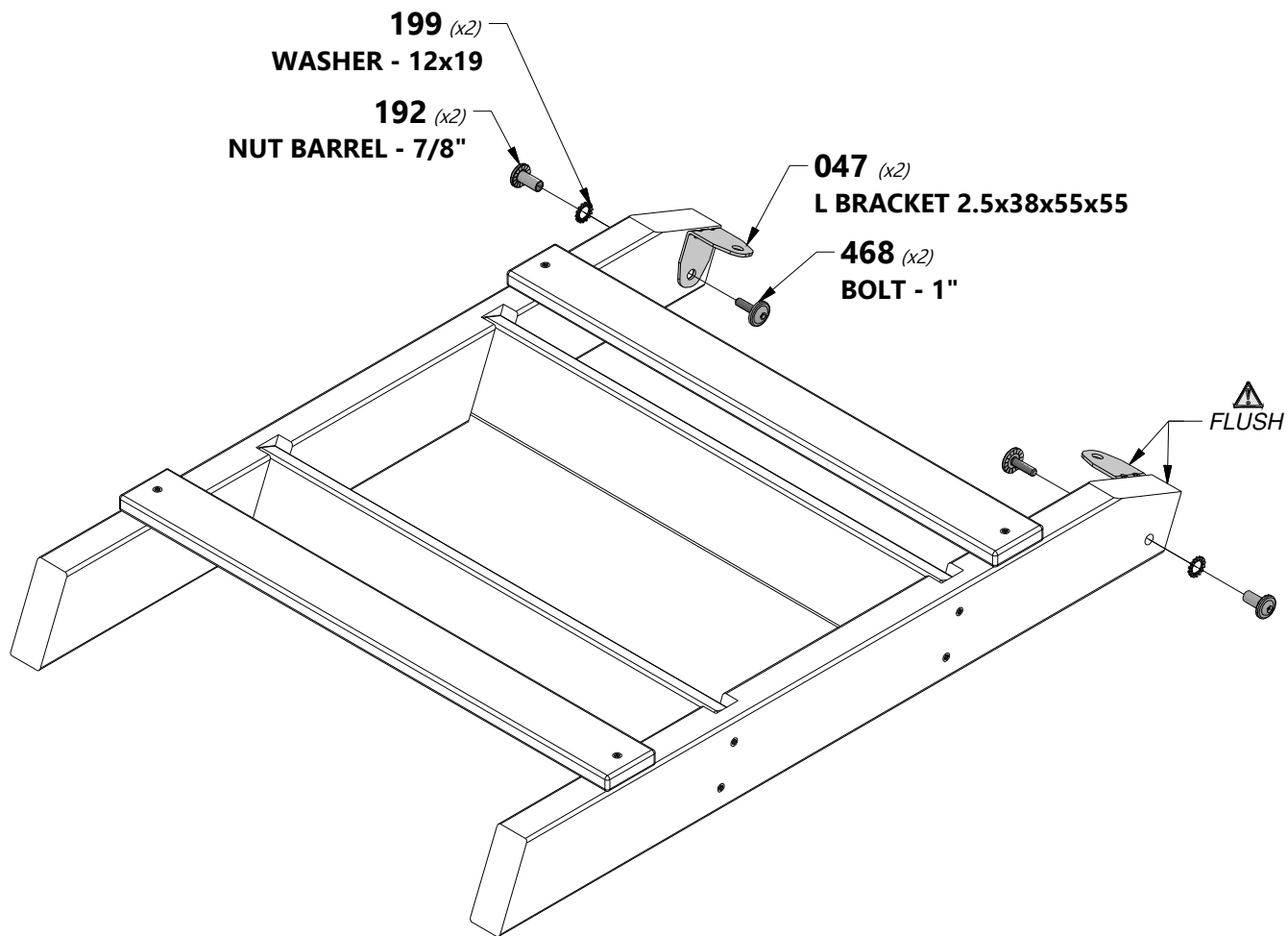

REPEAT THIS STEP TO COMPLETE THREE LADDER ASSEMBLIES



ROCK WALL ASSEMBLY

STEP 1



L1 | **ROCK WALL BOARD - W4L13916**
(x4) 5/8"x4 3/8"x26 1/4" (16x112x668)

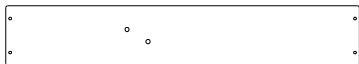

L2 | **ROCK WALL BOARD - W4L13917**
(x4) 5/8"x4 3/8"x26 1/4" (16x112x668)



L3 | **ROCK WALL BOARD - W4L13918**
(x5) 5/8"x4 3/8"x26 1/4" (16x112x668)

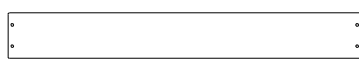

M09 | **ROCK WALL BOARD - W4L13920**
(x1) 5/8"x3 3/8"x26 1/4" (16x86x668)

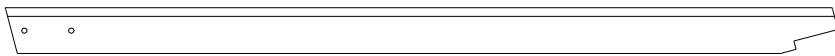

E05 | **ROCK WALL RAIL - W4L13976**
(x1) 1 3/8"x3 3/8"x63 5/8" (36x86x1575)

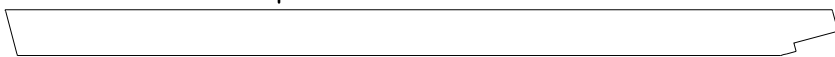

E04 | **ROCK WALL RAIL - W4L13972**
(x1) 1 3/8"x3 3/8"x62" (36x86x1575)



H100398 | **T-NUT BLK**
(x24) 1/4"



H100086 | **SCREW PFH**
(x56) 8x1 1/2"

PREPARATION: INSTALL T-NUTS

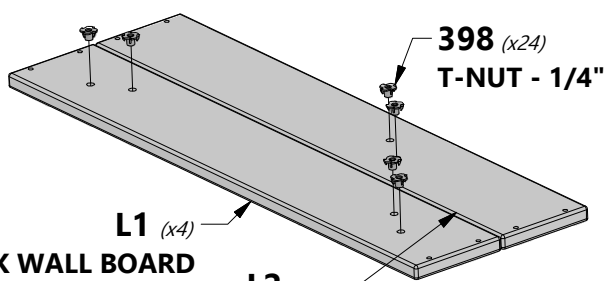

INSTALL T-NUTS AS SHOWN IN ALL L1 & L2 BOARDS.



ASSEMBLY NOTE:

USE THE FOLLOWING REPEATING PATTERN TO BUILD THE ROCK WALL. BEGINNING AT THE TOP THE PATTERN IS L3, L2, L1. REPEAT 4 TIMES AND END WITH AN ADDITIONAL L3 & M09 BOARD AS SHOWN. MAKE SURE TO PLACE EACH L2 BOARD SO THE HOLES ALTERNATE RIGHT TO LEFT OF CENTER.

NOTE: INSTALL ALL L1 & L2 BOARDS WITH T-NUTS FACING DOWN (HIDDEN).

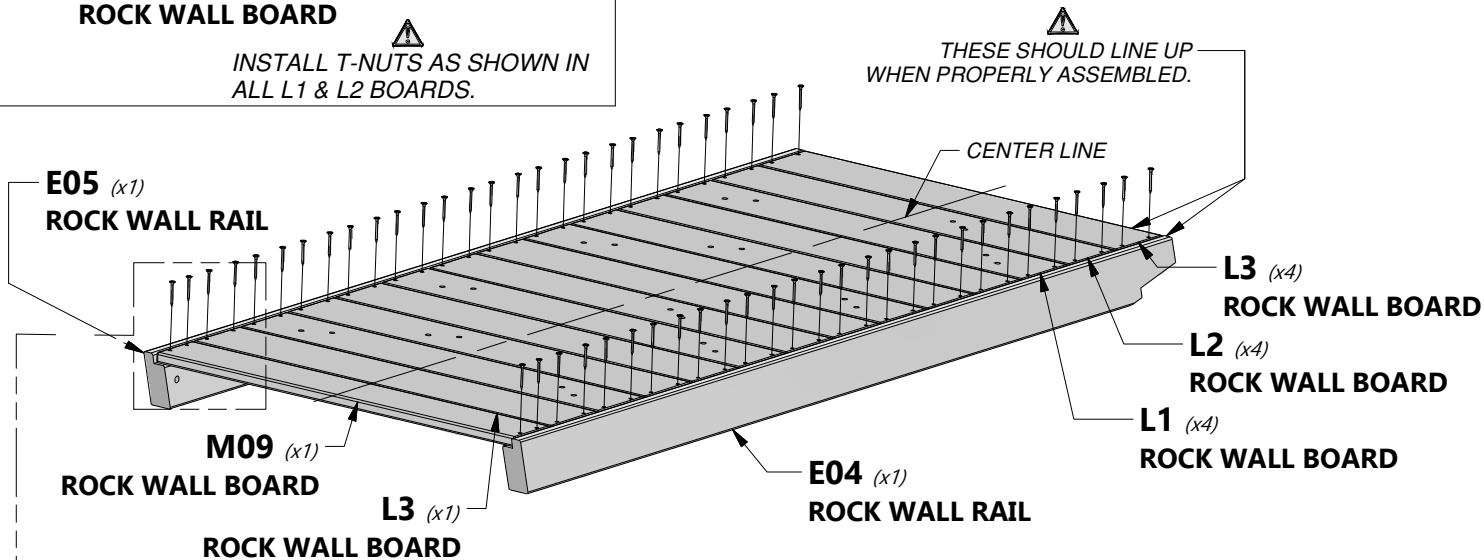

THESE SHOULD LINE UP WHEN PROPERLY ASSEMBLED.

CENTER LINE

086 (x56)
SCREW - 1 1/2"

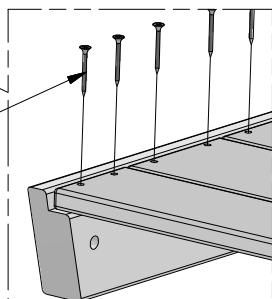

ASSEMBLY TIP:

IT CAN HELP TO SET ALL THE BOARDS IN PLACE TO MAKE SURE THEY MATCH THE DIAGRAM PRIOR TO MOUNTING THEM WITH THE PROVIDED SCREWS.



M10 | **ROCK WALL BOARD - W4L13948**
(x1) | 5/8"x3 3/8"x27 5/8" (16x86x702)



H100379 | **T-NUT BLK**
(x2) | 5/16"



H100086 | **SCREW PFH**
(x4) | 8x1 1/2"

PREPARATION: INSTALL T-NUTS

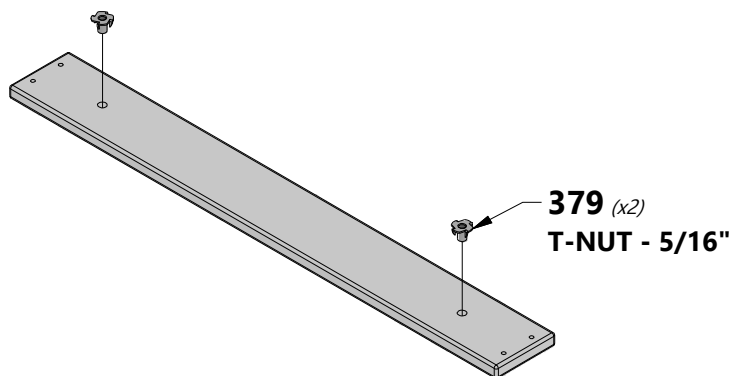

379 (x2)
T-NUT - 5/16"

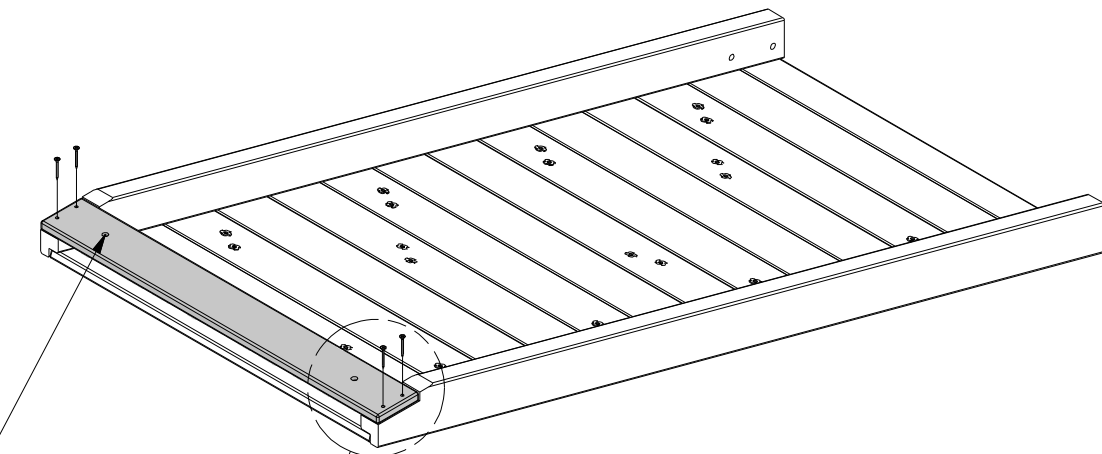

 **NOTE PRE-INSTALLED T-NUTS MUST FACE DOWN.**

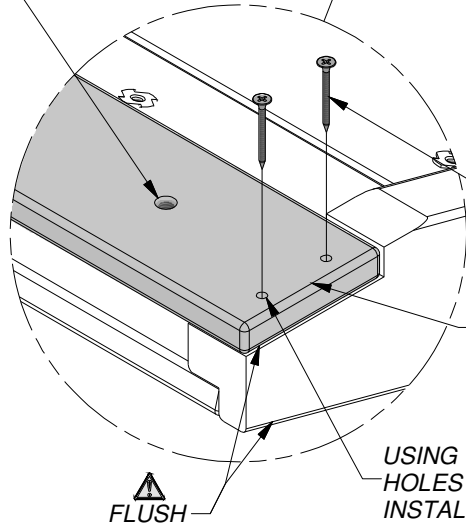

086 (x4)
SCREW - 1 1/2"

M10 (x1)
ROCK WALL BOARD

 **FLUSH**

 **USING THE M10 BOARD AS A GUIDE, PRE-DRILL HOLES WITH A 1/8" (3mm) DRILL BIT PRIOR TO INSTALLING '086' SCREWS..**

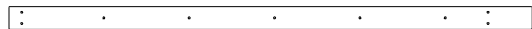

N04 | ROCKWALL CLEAT - W4L13955
(x1) | 5/8"x2 3/8"x54 1/2" (16x60x1385)



N05 | ROCK WALL BOARD - W4L13958
(x1) | 5/8"x2 3/8"x27 5/8" (16x60x702)



H100086 | SCREW PFH
(x4) | 8x1 1/2



H100088 | SCREW PFH
(x9) | 8x1 1/8

BOTTOM VIEW

NOTE:
PLACE AND CENTER N04 BOARD AS SHOWN.

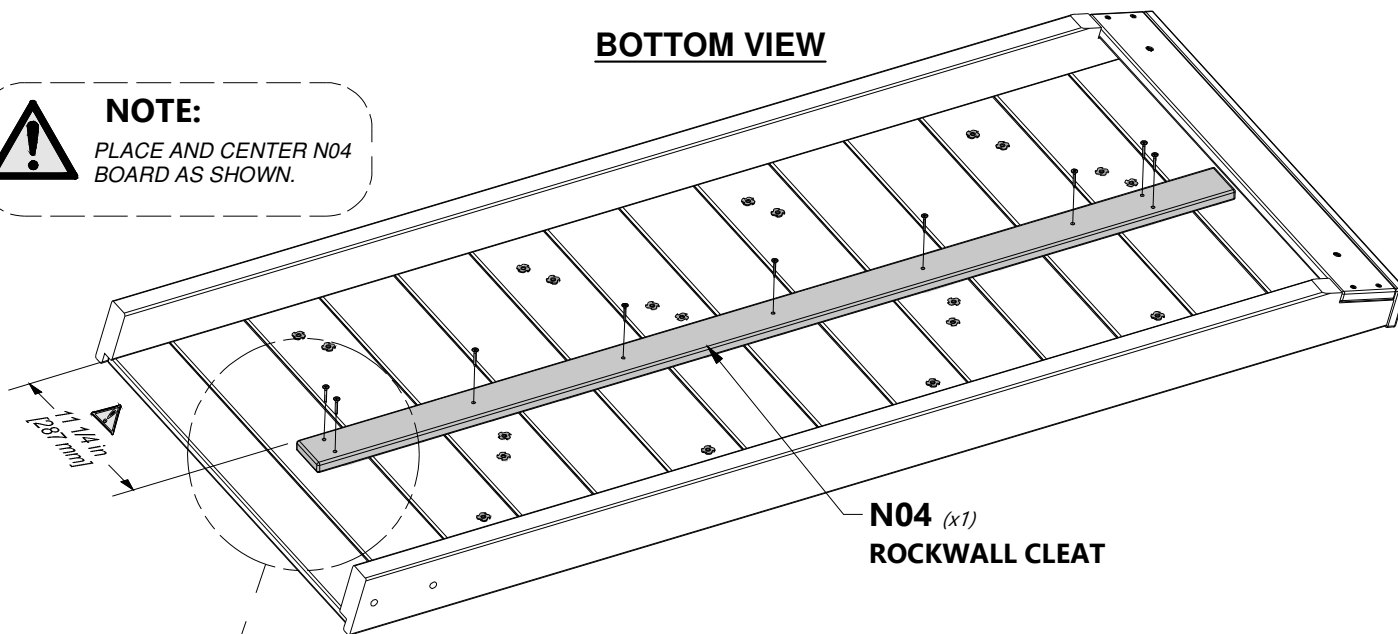

N04 (x1)
ROCKWALL CLEAT

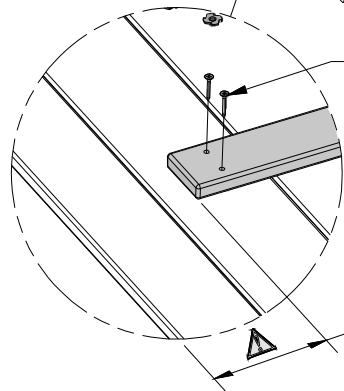

088 (x9)
SCREW - 1 1/8"

TOP VIEW

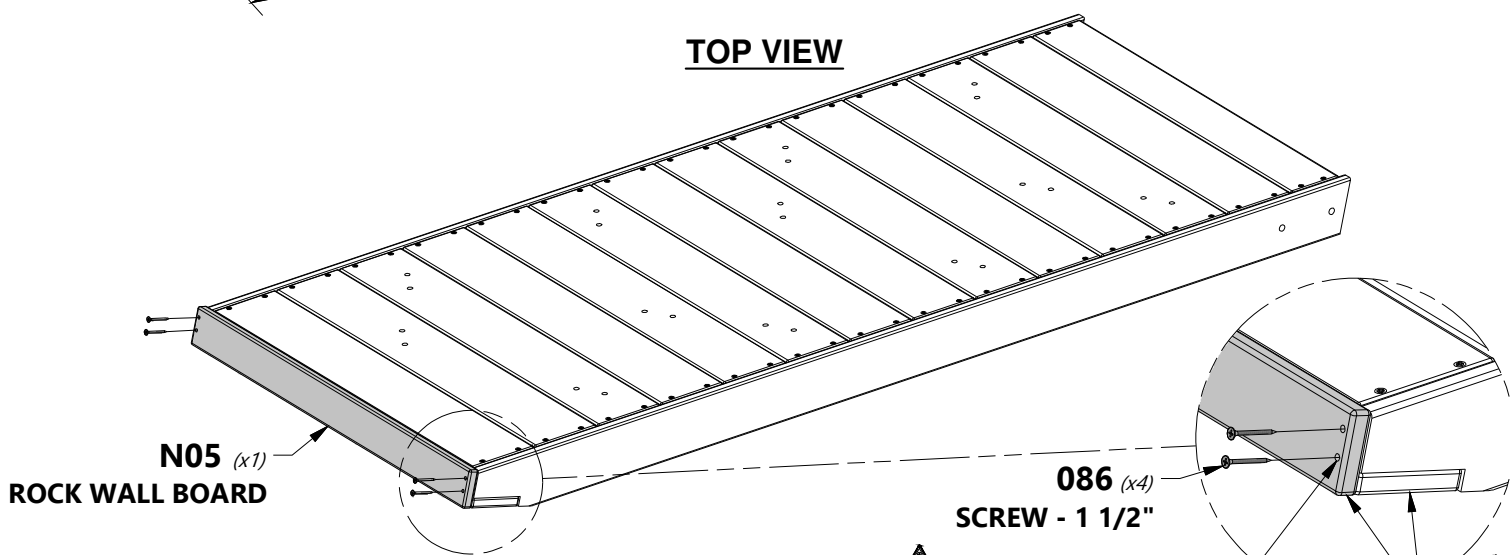

N05 (x1)
ROCK WALL BOARD

086 (x4)
SCREW - 1 1/2"

PRE-DRILL HOLES USING A 1/8" (3MM) DRILL BIT.

FLUSH



ROCK WALL ASSEMBLY

STEP 4



A6P00037 | GREEN HC ROCK #2
(x8)



A6P00036 | GREEN HC ROCK #1
(x4)



H100489 | BOLT PTH BLK
(x24) | 1/4x3/4



H100473 | WASHER LOCK INT BLK
(x24) | 8x15



NOTE:

INSTALL ROCKS USING THE SHOWN HARDWARE WITH THE T-NUTS THAT WERE PRE-INSTALLED.



NOTE ARROW SHOULD FACE UP.

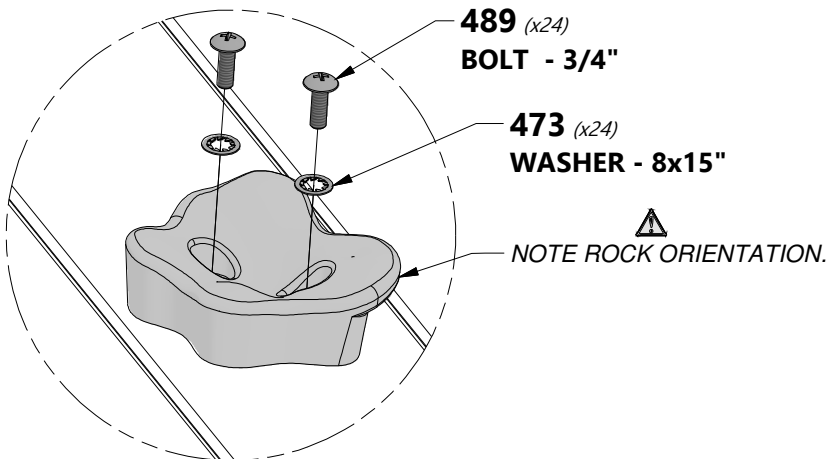

489 *(x24)*
BOLT - 3/4"

473 *(x24)*
WASHER - 8x15"

NOTE ROCK ORIENTATION.

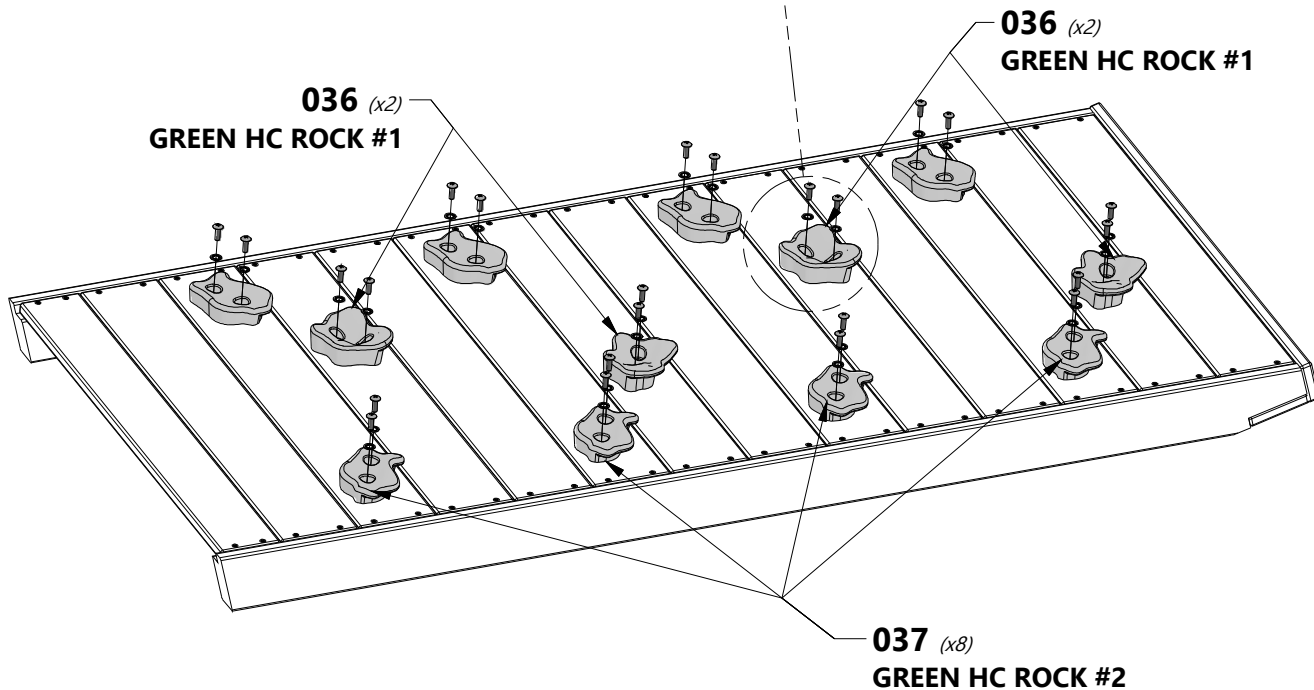

036 *(x2)*
GREEN HC ROCK #1

036 *(x2)*
GREEN HC ROCK #1

037 *(x8)*
GREEN HC ROCK #2

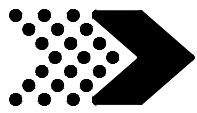

SWING BEAM

STEP 1

A1 | SWING BEAM - W4L13989
(x1) | 3 3/8"x5 1/4"x89 1/2" (86x134x2274)

A2 | SB 9" BLOCK - W4L13990
(x1) | 3 3/8"x5 1/4"x9" (86x134x228)

A100325 | SWING BEAM
EXTENSION
BRACKET-LEFT
(x1)

A100326 | SWING BEAM
EXTENSION
BRACKET-RIGHT
(x1)

A4M00993 | EXTENDED
SWING BEAM
BRACKET
(x2)

H100416 | BOLT WH BLK
(x10) | 5/16x3

H100192 | NUT BARREL WH BLK
(x10) | 5/16x7/8

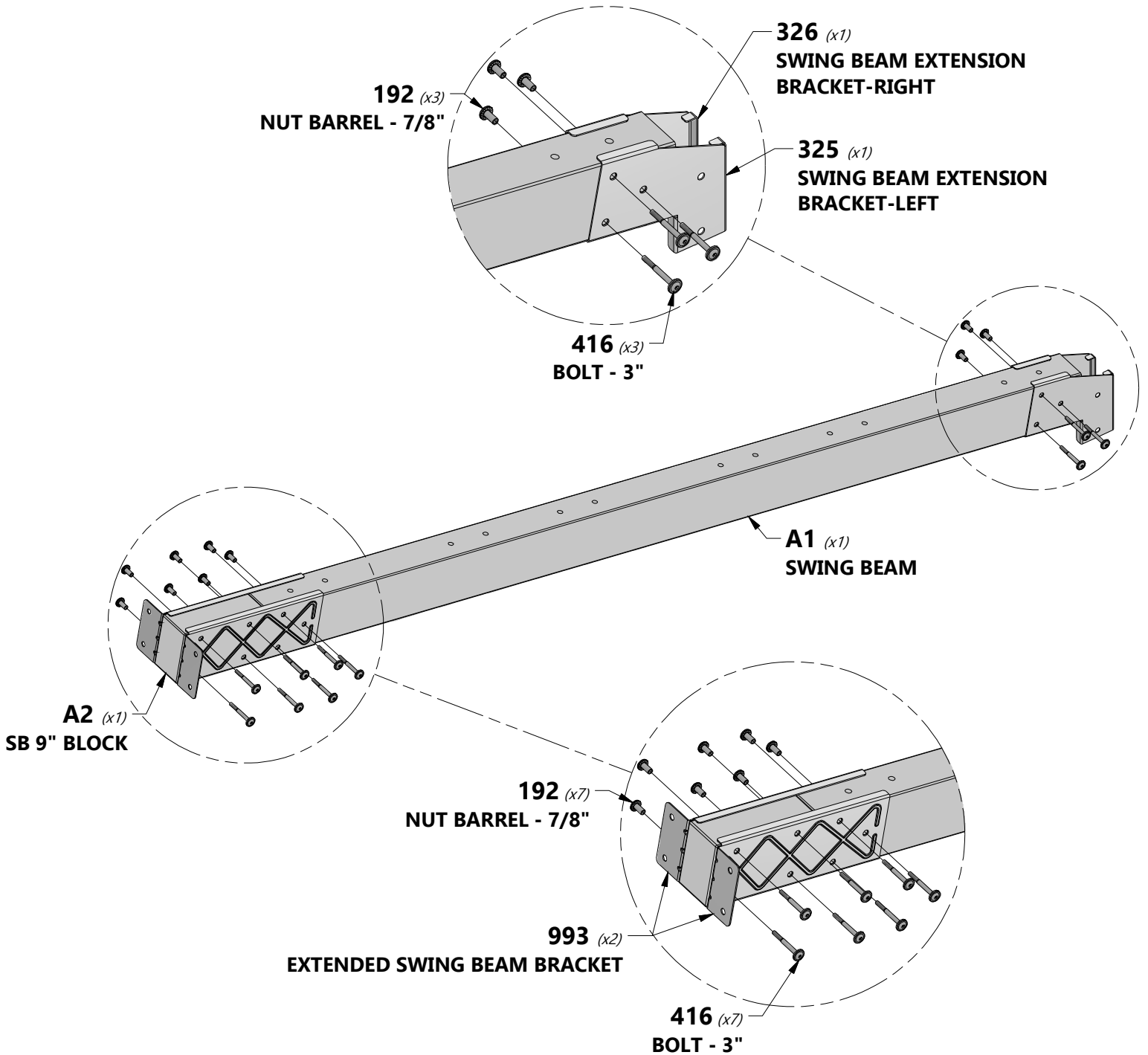

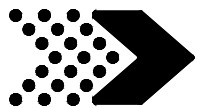

SWING BEAM

STEP 2

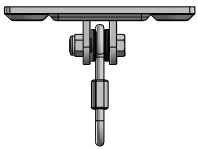

A4M00505 | SWING HANGER
(x6)



H100654 | BOLT HEX
(x12) | 3/8x5-1/2

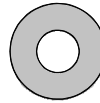

H100102 | WASHER FLAT
(x12) | 11x25



H100107 | WASHER LOCK INT
(x12) | 10x18

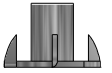

H100073 | T-NUT
(x12) | 3/8

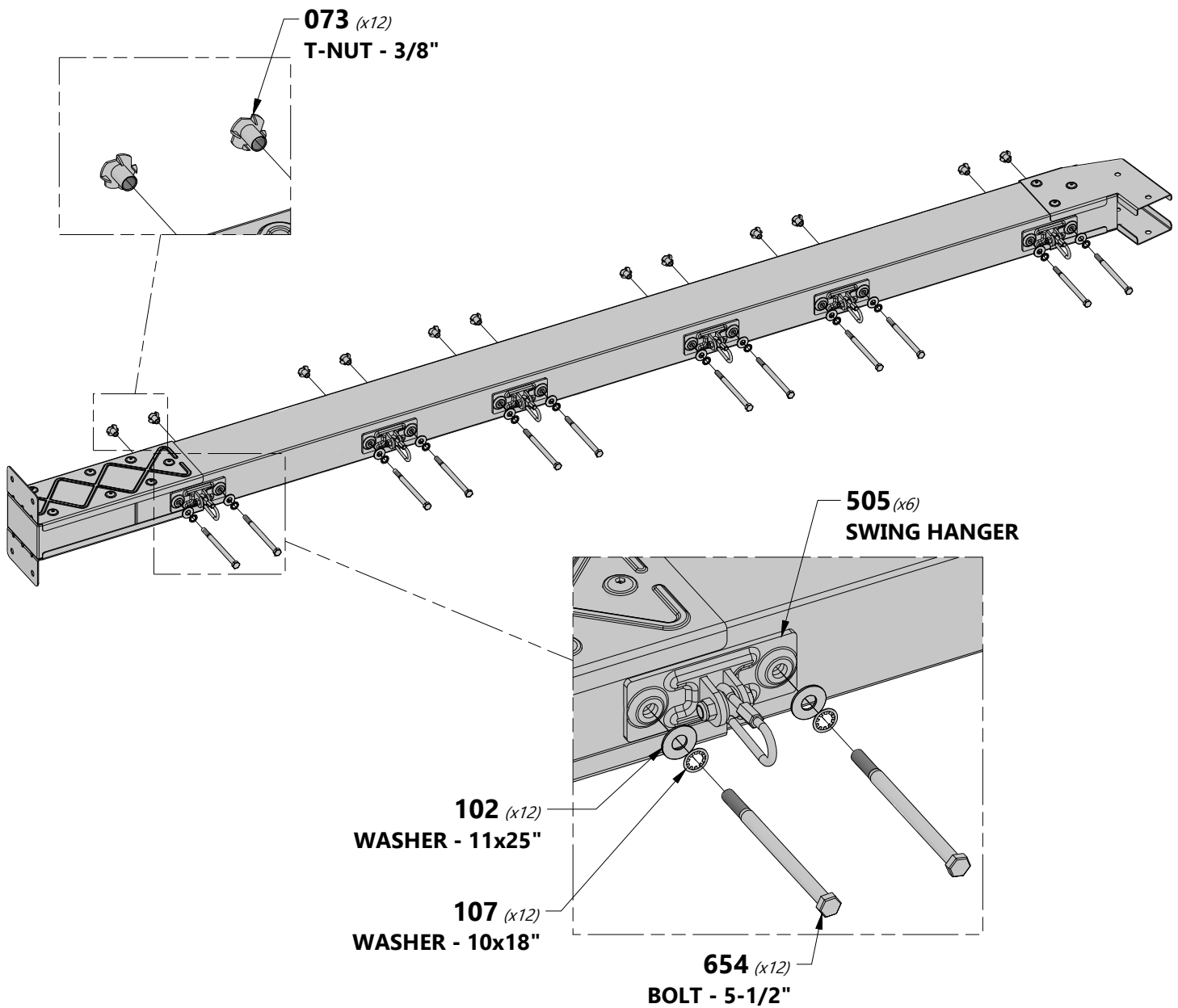

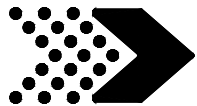

SWING BEAM

E06 | S.B. ANGLE BRACE - W4L13993
(x2) | 1 7/16"x3 3/8"x87 3/16" (36x86x2214)

G11 | GROUND BOARD - W4L13991
(x1) | 1"x5 1/4"x86 3/4" (24x134x2202)

SP1 | SWING BEAM SUPPORT - W4L13988
(x1) | 3 3/8"x3 3/8"x49 3/8" (86x86x1254)

A4M01169 | A-FRAME BRACKET
(x1)

E07 | S.B. END SUPPORT - W4L13992
(x1) | 1 3/8"x3 3/8"x44 1/8" (36x86x1120)

STEP 3

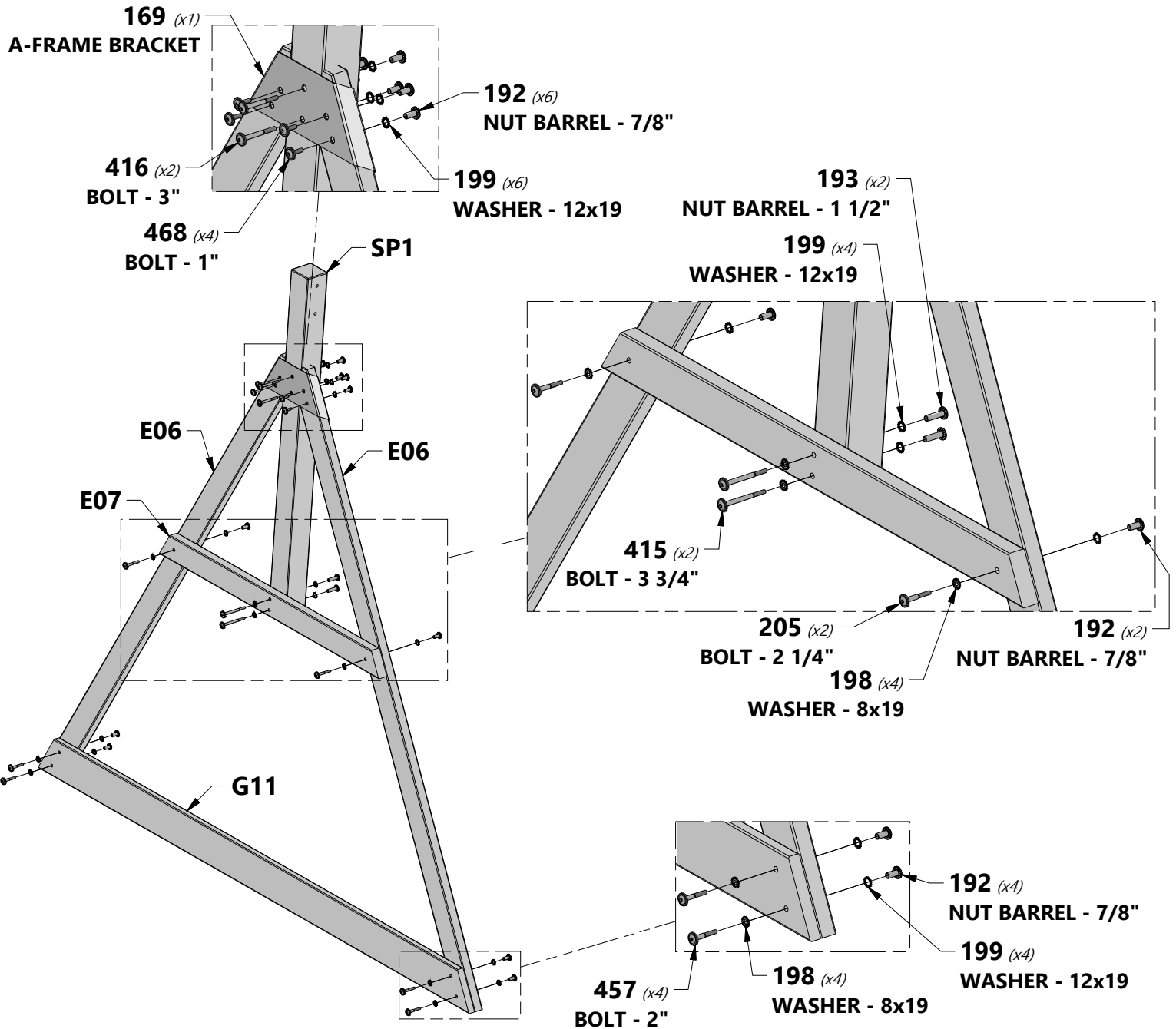
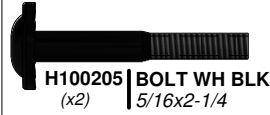
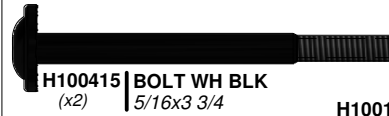
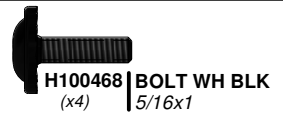
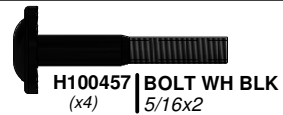

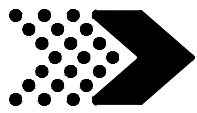

SWING BEAM

STEP 4

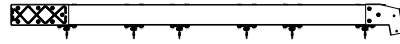
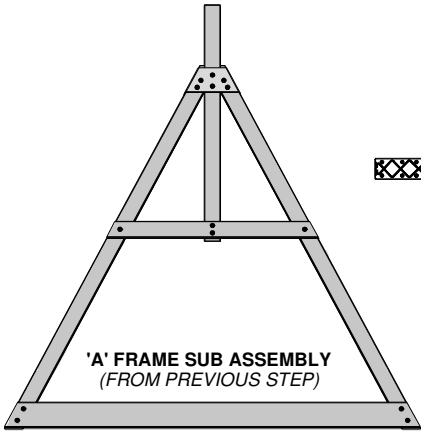

SWING BEAM SUB ASSEMBLY
(FROM PREVIOUS STEP)



H100416 | BOLT WH BLK
(x2) | 5/16x3

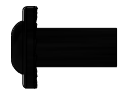

H100192 | NUT BARREL WH BLK
(x2) | 5/16x7/8

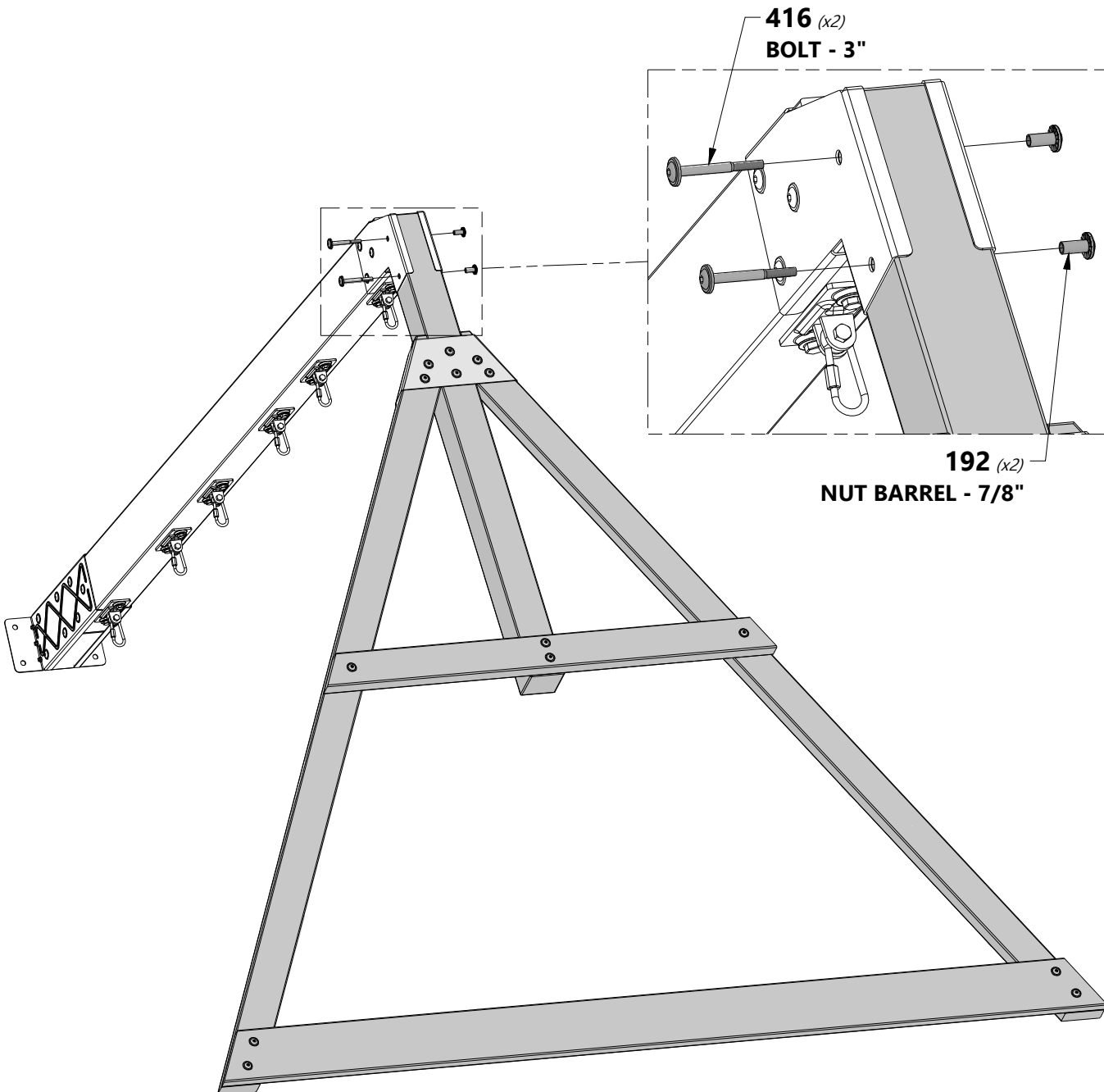

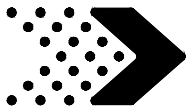

SETUP

WEB SWING

WEB SWING SETUP INSTRUCTIONS:

FOLLOW INSTRUCTIONS BELOW BEFORE USING THE WEB SWING.



H100832 | BOLT PTH
(4) | 1/4x3/4



H100831 | NUT BARREL PTH BLK
(4) | 1/4x3/4



IMPORTANT:
SLIDE ROPE LOOPS OVER TUBE ENDS FIRST!

SLIDE NARROW END OF TUBES INTO LARGER OPENING AFTER SLIDING ROPE LOOPS ONTO TUBES.

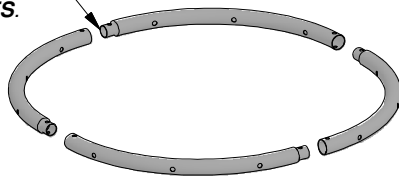

NOTE: ROPE WEBBING NOT SHOWN IN ILLUSTRATION FOR CLARITY.

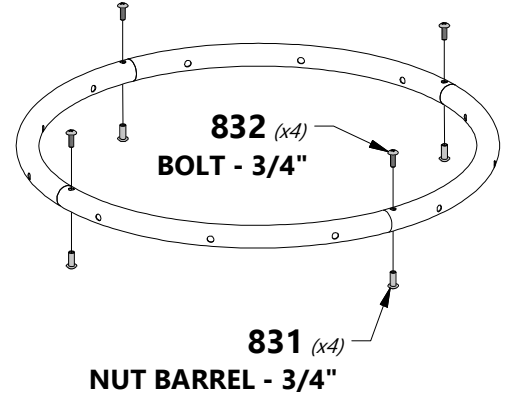

Note: It is important that the web swing hang level.



IMPORTANT

TO ENSURE STRAIGHT SWINGING MOTION, ADJUST BOTH "S" BRACKETS UNTIL WEB SEAT IS LEVEL.



IMPORTANT:

SWING MUST BE SET AT A MINIMUM OF 8 INCHES OFF THE GROUND WHEN INSTALLED.

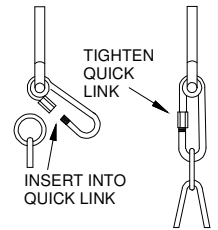
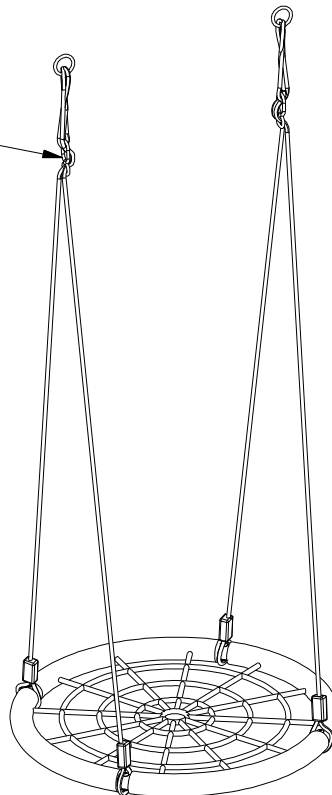



FORT ASSEMBLY

STEP 1

B02 | POST - W4L13915
(x1) | 3"x3"x86 7/8" (76x76x2207)

B03 | POST - W4L13902
(x1) | 3"x3"x86 7/8" (76x76x2207)

B05 | POST - W4L13986
(x1) | 3"x3"x86 7/8" (76x76x2207)

H05 | RAIL - W4L13932
(x1) | 1"x3 3/8"x34 1/2" (24x86x876)

G01 | GROUND BOARD - W4L13907
(x1) | 1"x5 1/4"x67 7/8" (24x134x1724)

G07 | FLOOR RAIL - W4L13953
(x1) | 1"x5 1/4"x66" (24x134x1676)

H02 | RAIL - W4L13985
(x1) | 1"x3 3/8"x34 1/2" (24x86x876)

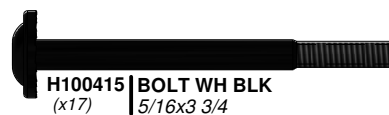

H100415 | BOLT WH BLK
(x17) | 5/16x3 3/4



H100379 | T-NUT BLK
(x17) | 5/16



H100198 | WASHER LOCK EXT BLK
(x17) | 8x19

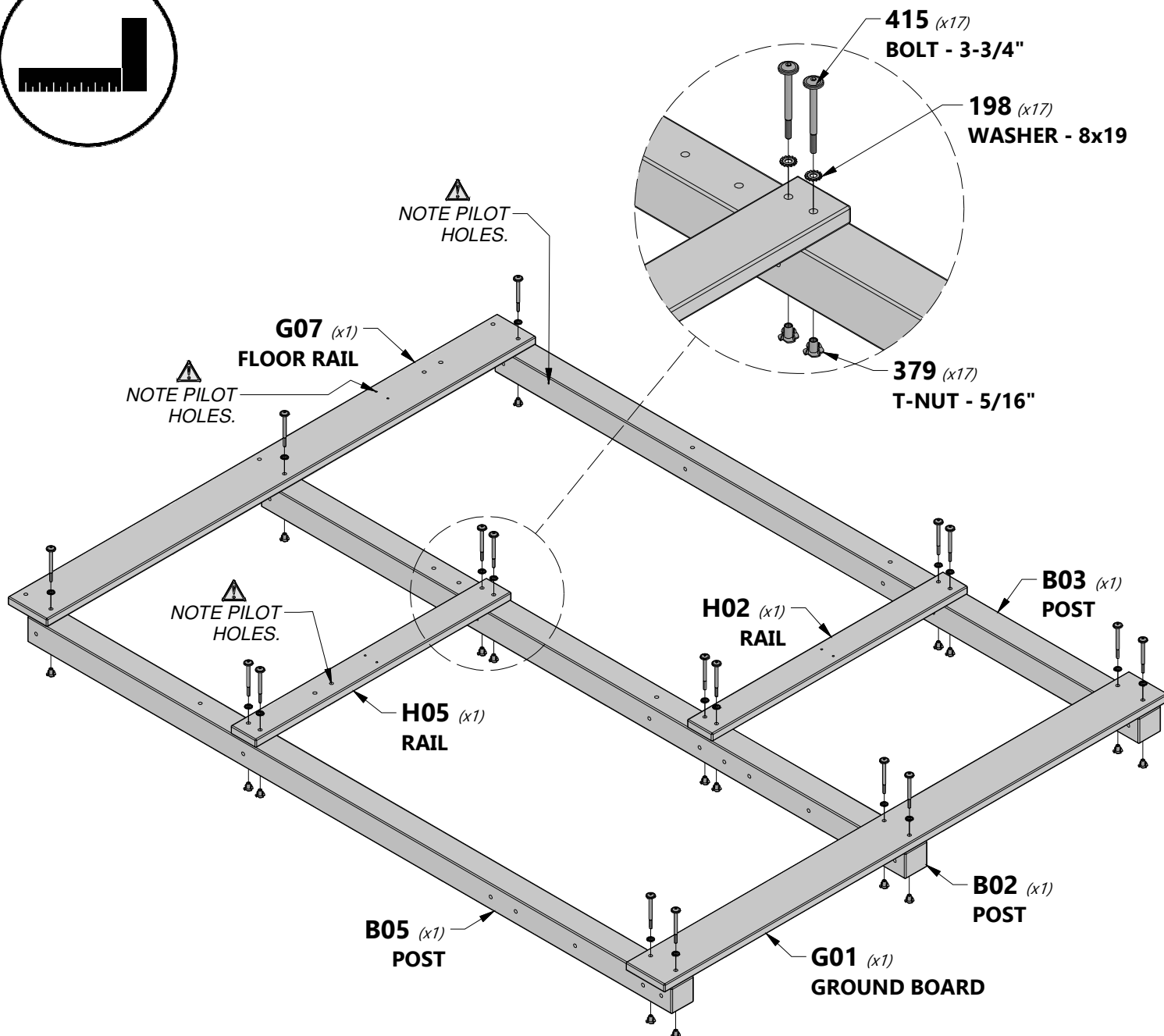
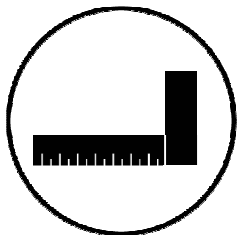

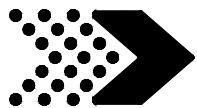

FORT ASSEMBLY

STEP 2

- G02** | GROUND BOARD - W4L13984
(x1) | 1"x5 1/4"x86 1/8" (24x134x2187)
- B04** | POST - W2A03074
(x1) | 3 1/16"x3"x86 7/8" (78x76x2207)
- B01** | POST - W4L13900
(x1) | 3"x3"x86 7/8" (76x76x2207)
- B06** | POST - W4L13987
(x1) | 3"x3"x86 7/8" (76x76x2207)

- G06** | FLOOR RAIL - W4L13908
(x1) | 1"x5 1/4"x66" (24x134x1676)
- H02** | RAIL - W4L13985
(x1) | 1"x3 3/8"x34 1/2" (24x86x876)
- H05** | RAIL - W4L13932
(x1) | 1"x3 3/8"x34 1/2" (24x86x876)

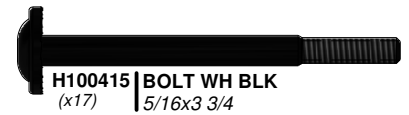

H100198 | WASHER LOCK EXT BLK
(x17) | 8x19

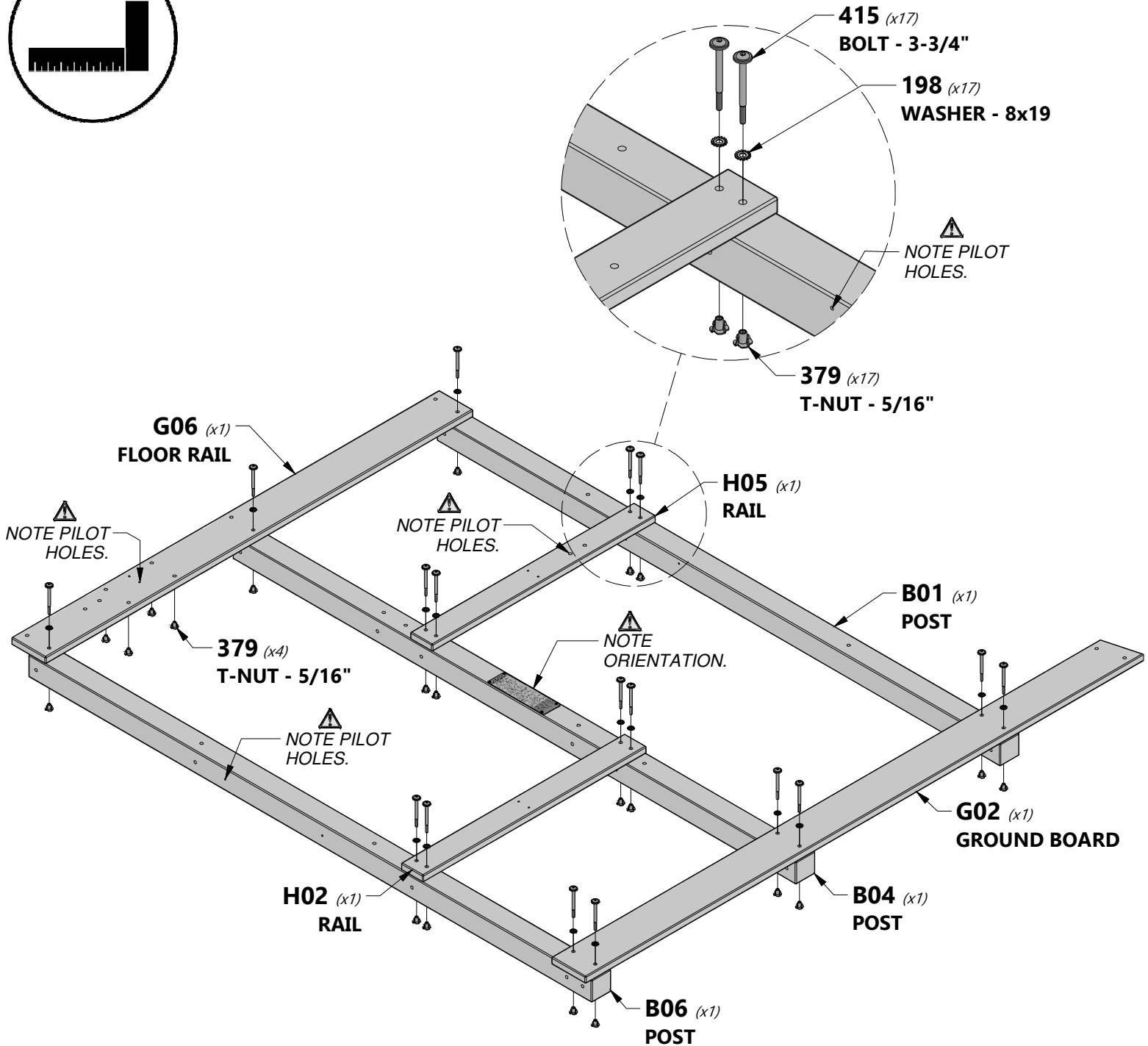
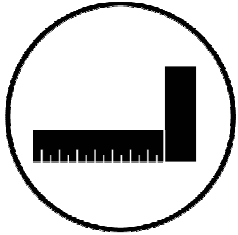

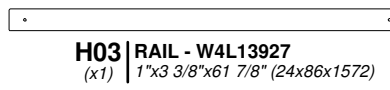
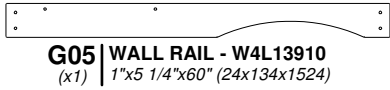
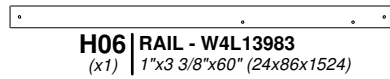
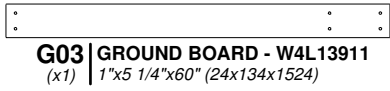
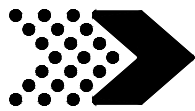

H100198 | WASHER LOCK EXT BLK
(x10) | 8x19



H100379 | T-NUT BLK
(x10) | 5/16

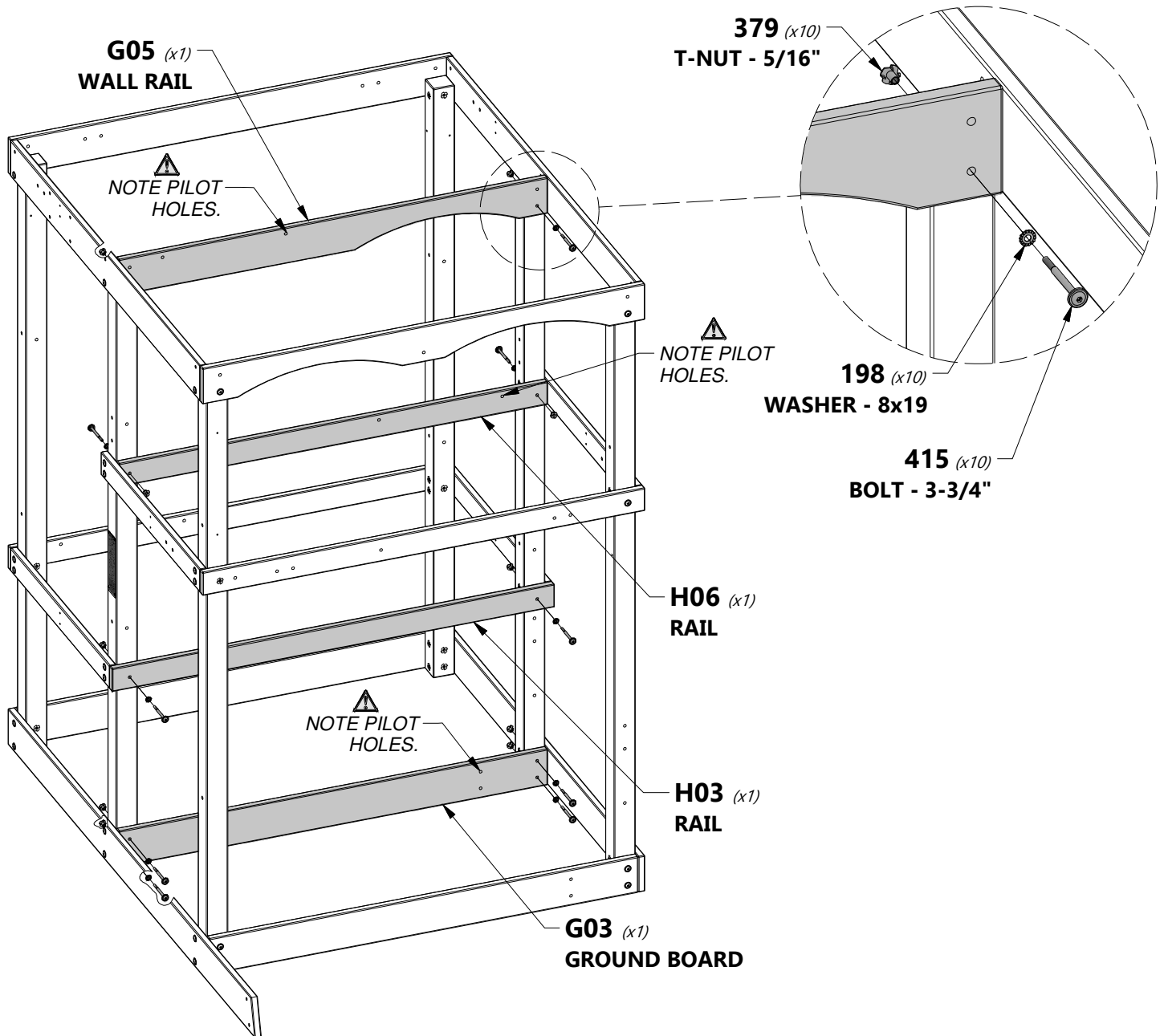

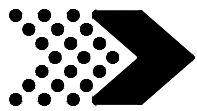

FORT ASSEMBLY

STEP 5

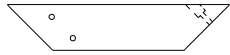

E01 | ANGLE BRACE - W4L13971
(x8) | 1 3/8"x3 3/8"x16 1/2" (36x86x420)



H100205 | BOLT WH BLK
(x16) | 5/16x2-1/4



H100456 | LAG SCREW WH BLK
(x8) | 1/4x2 1/2



H100198 | WASHER LOCK EXT BLK
(x16) | 8x19



H100405 | WASHER LOCK EXT BLK
(x8) | 6x15



H100379 | T-NUT BLK
(x16) | 5/16

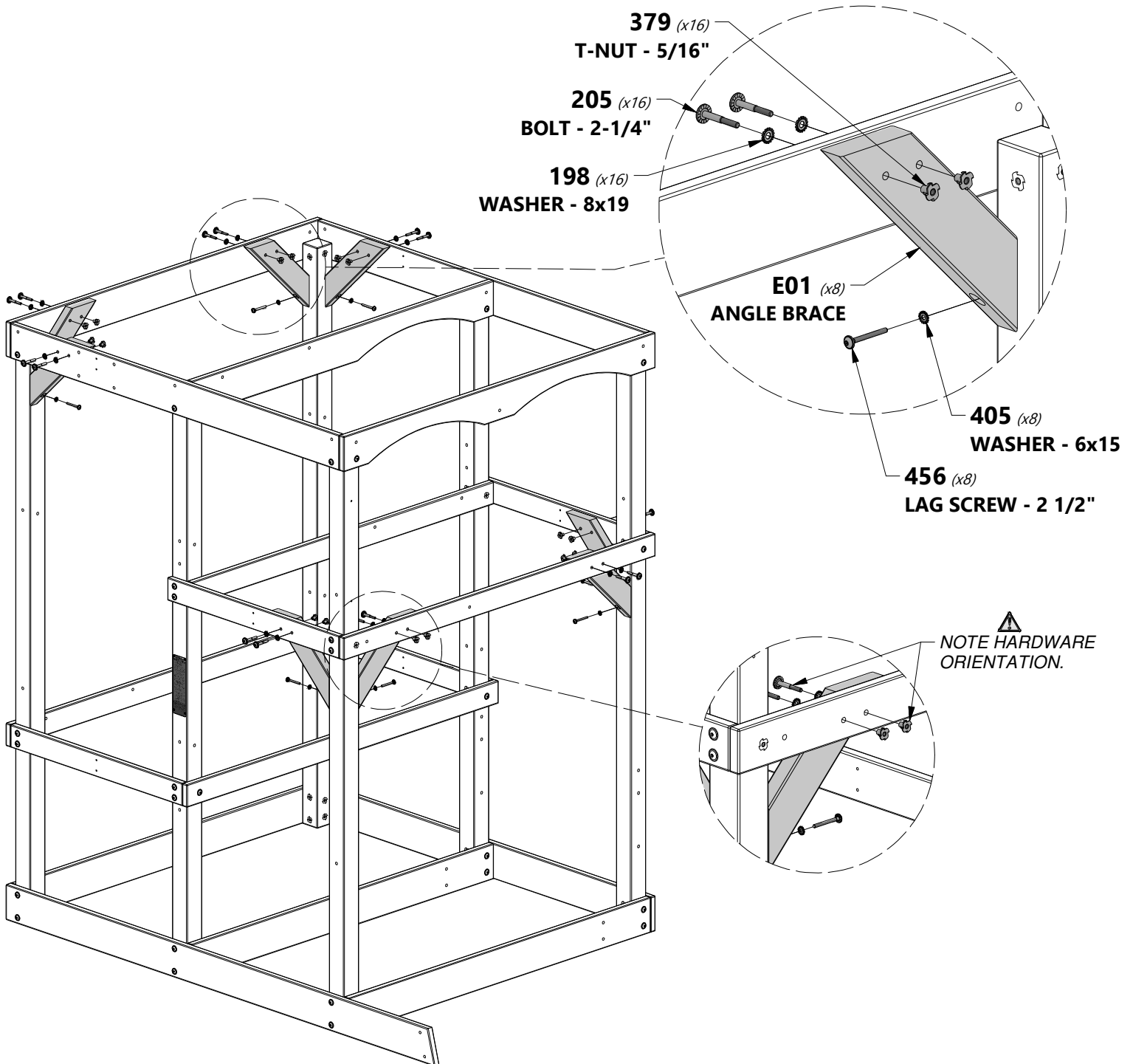

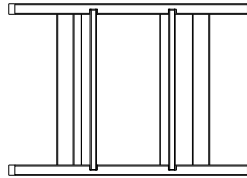
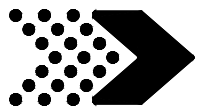

LADDER ASSEMBLY
FROM PREVIOUS STEPS



H100468 | BOLT WH BLK
(x2) | 5/16x1



H100379 | T-NUT BLK
(x2) | 5/16

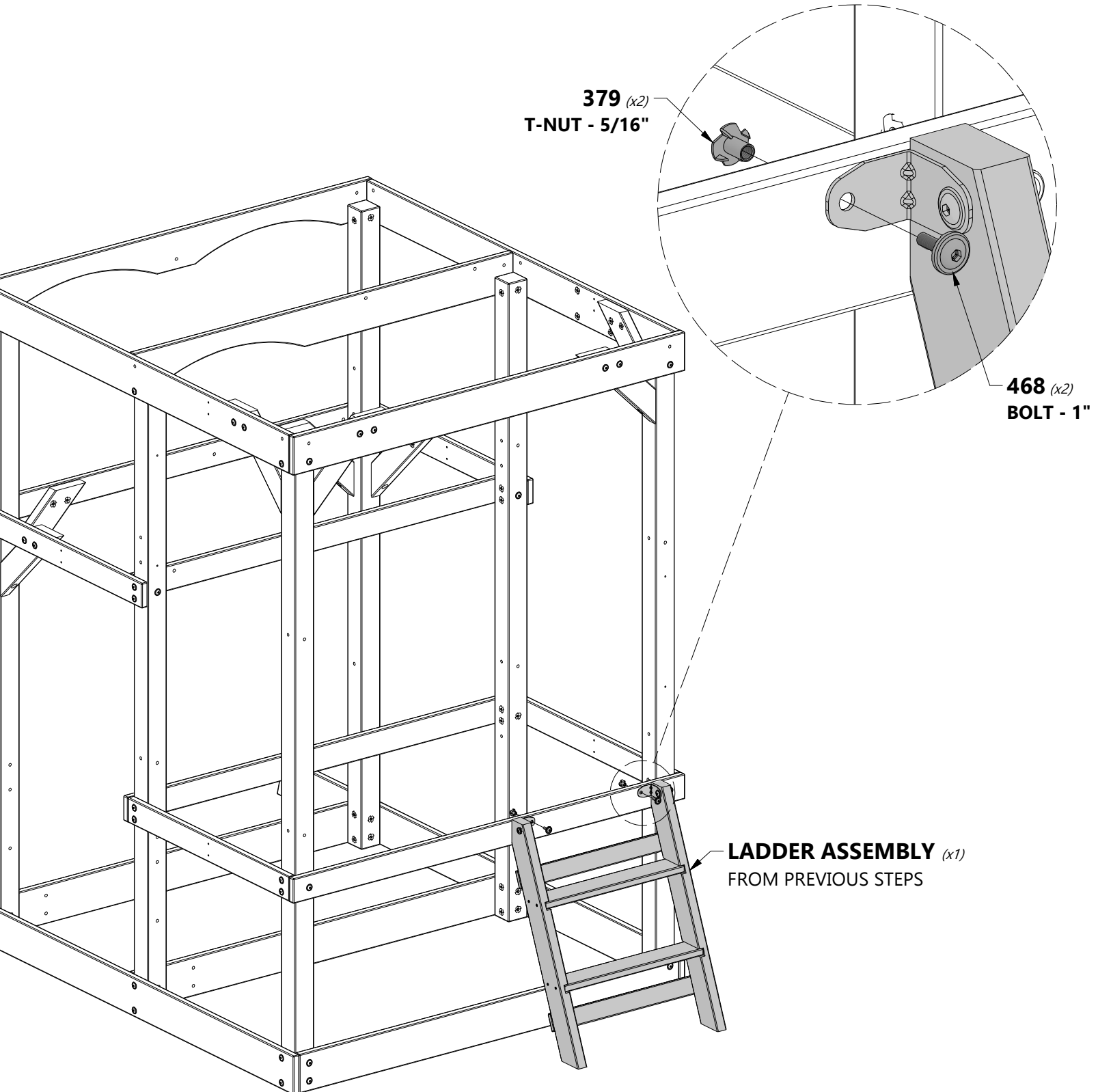

379 (x2)
T-NUT - 5/16"

468 (x2)
BOLT - 1"

LADDER ASSEMBLY (x1)
FROM PREVIOUS STEPS

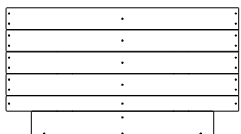
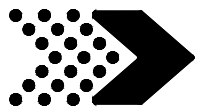

HH1 | FLOOR PANEL - W2A03079
(x1) | 1 1/4"x20 1/8"x36 3/8" (32x510x924)

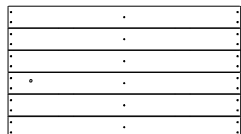

HH2 | FLOOR PANEL - W2A03080
(x1) | 36 3/8"x1 1/4"x20 9/16" (924x32x522)

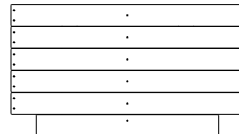

HH3 | FLOOR PANEL - W2A03078
(x1) | 36 3/8"x1 1/4"x21 1/8" (924x32x536)

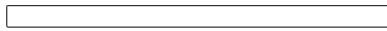

H04 | RAIL - W4L13928
(x1) | 1"x3 3/8"x60" (24x86x1524)



H100201 | SCREW PFH BLK
(x4) | 8x2-1/2



H100086 | SCREW PFH
(x86) | 8x1 1/2



NOTE:
INSTALL H04 RAIL FIRST, THEN
INSTALL THE FLOOR PANELS AS
SHOWN.

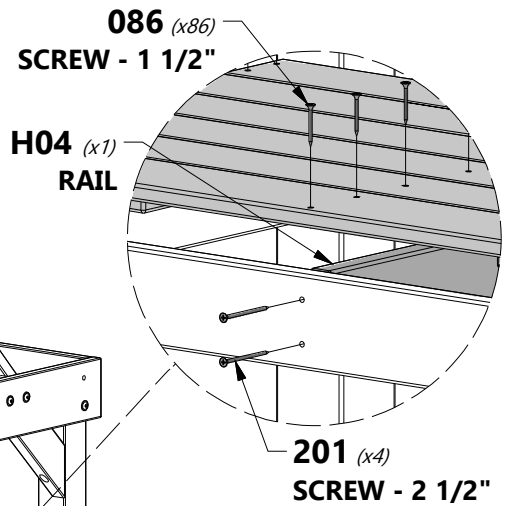
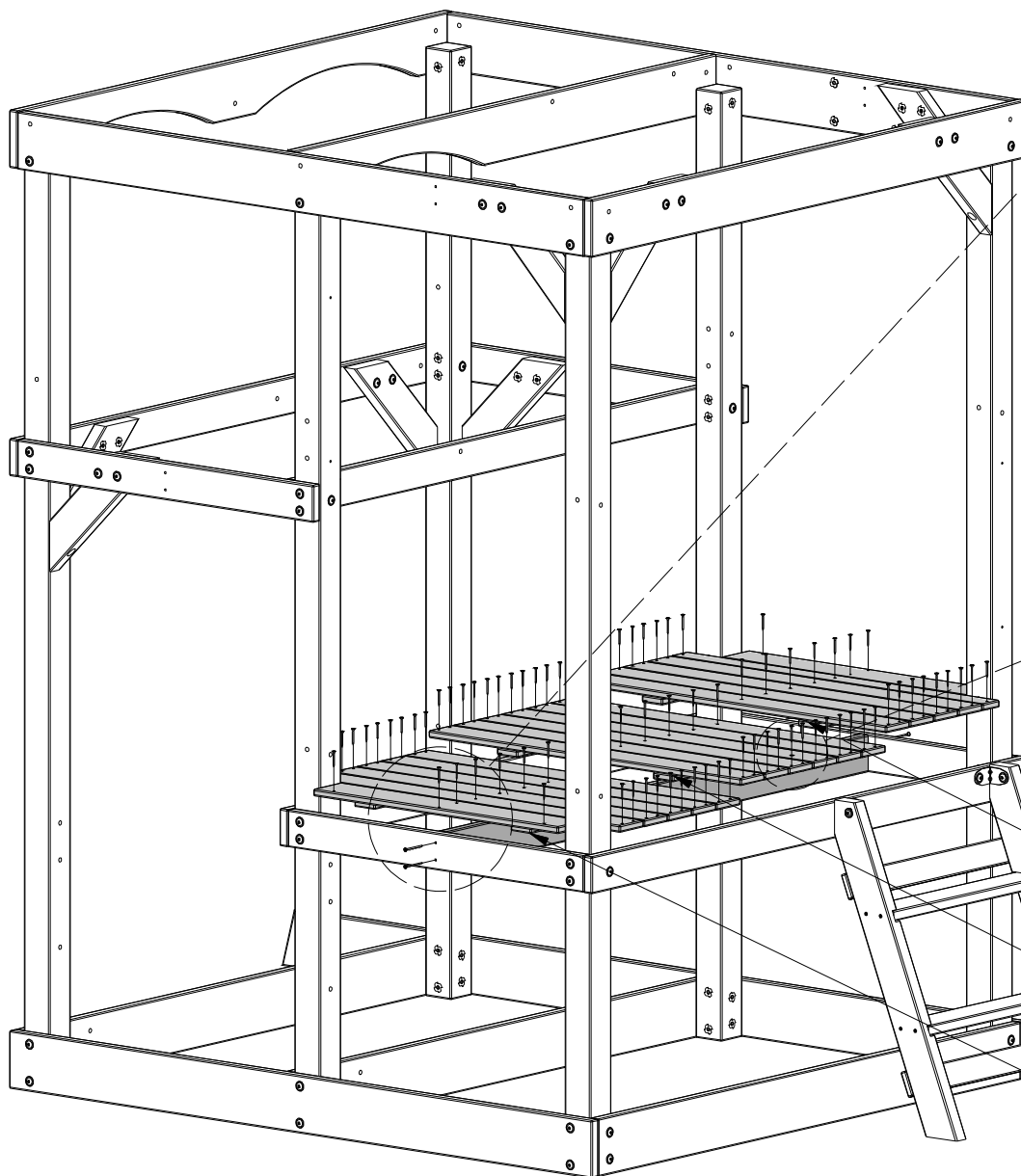

086 (x86)
SCREW - 1 1/2"

H04 (x1)
RAIL

201 (x4)
SCREW - 2 1/2"

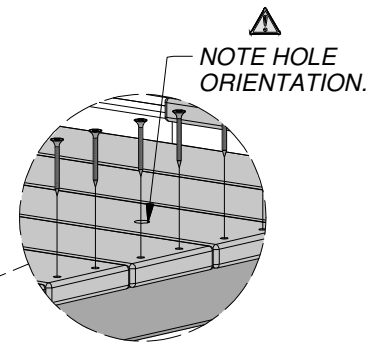

**NOTE HOLE
ORIENTATION.**

HH1 (x1)
FLOOR PANEL

HH2 (x1)
FLOOR PANEL

HH3 (x1)
FLOOR PANEL

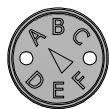

A100314 (x1) "A" REVISION TAG



H100202 SCREW PWH BLK (x2) 8x5/8



H100379 T-NUT BLK (x4) 5/16

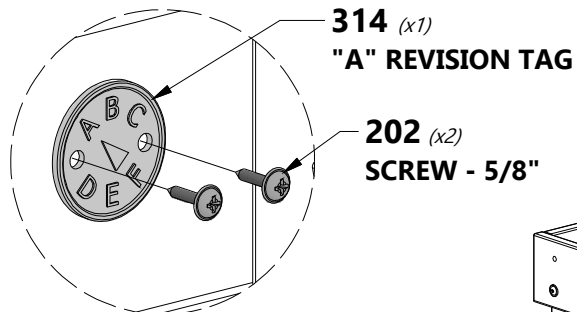

379 (x2) T-NUT - 5/16"

379 (x2) T-NUT - 5/16"

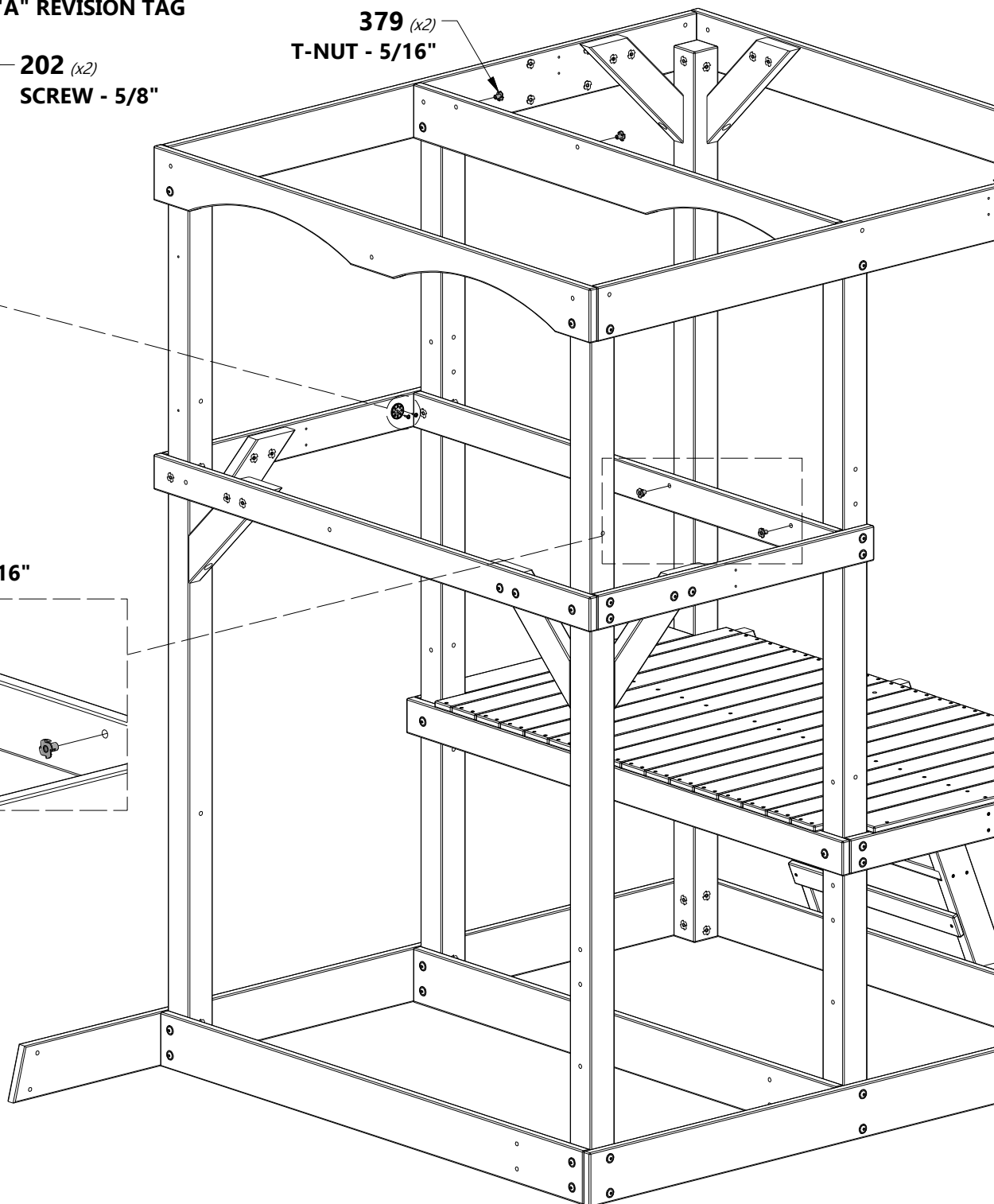
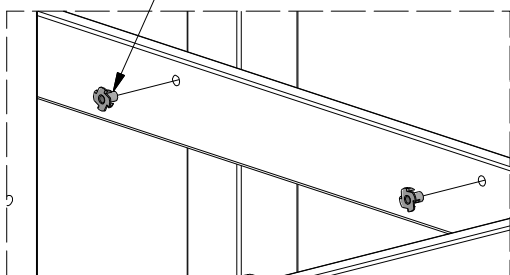

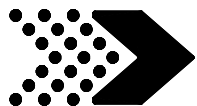

FORT ASSEMBLY

STEP 9

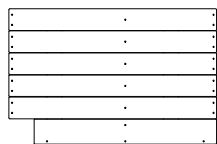

HH4 FLOOR PANEL - W2A03075
(x1) | 32 7/16"x1 1/4"x21 1/8" (824x32x536)



HH5 FLOOR PANEL - W2A03076
(x1) | 1 1/4"x20 9/16"x32 7/16" (32x522x824)

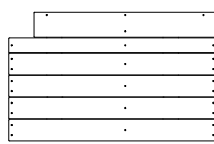

HH6 FLOOR PANEL - W2A03077
(x1) | 1 1/4"x20 1/8"x32 7/16" (32x510x824)

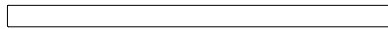

H04 RAIL - W4L13928
(x1) | 1"x3 3/8"x60" (24x86x1524)



H100201 | SCREW PFH BLK
(x4) | 8x2-1/2



H100086 | SCREW PFH
(x86) | 8x1 1/2



NOTE:
INSTALL H04 RAIL FIRST, THEN
INSTALL THE FLOOR PANELS AS
SHOWN.

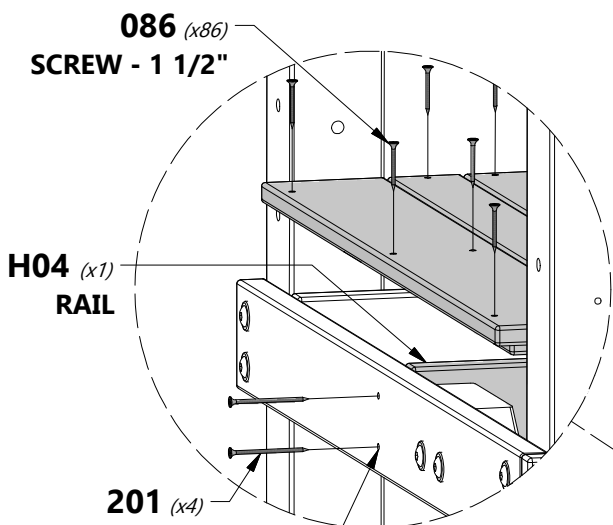

086 (x86)
SCREW - 1 1/2"

H04 (x1)
RAIL

201 (x4)
SCREW - 2 1/2"

NOTE PILOT
HOLES.

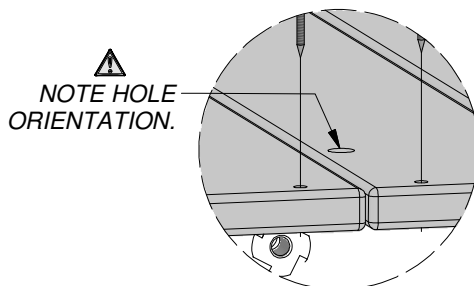

NOTE HOLE
ORIENTATION.

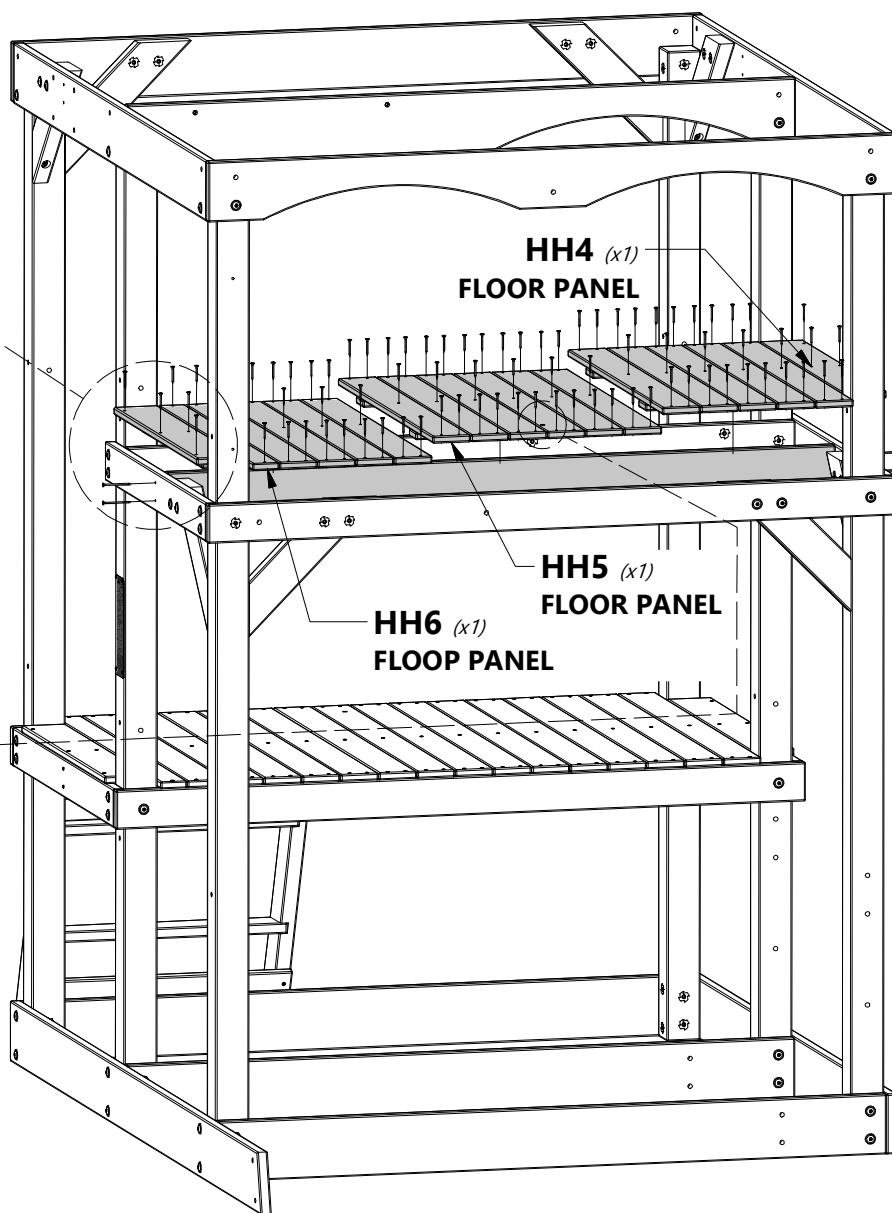

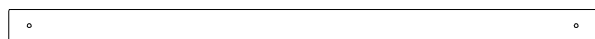

M02 | WALL RAIL - W4L13943
(x1) | 5/8"x3 3/8"x61 1/4" (16x86x1556)



H100503 | BOLT WH BLK
(x2) | 5/16x3 1/2



H100198 | WASHER LOCK EXT BLK
(x2) | 8x19



H100379 | T-NUT BLK
(x2) | 5/16

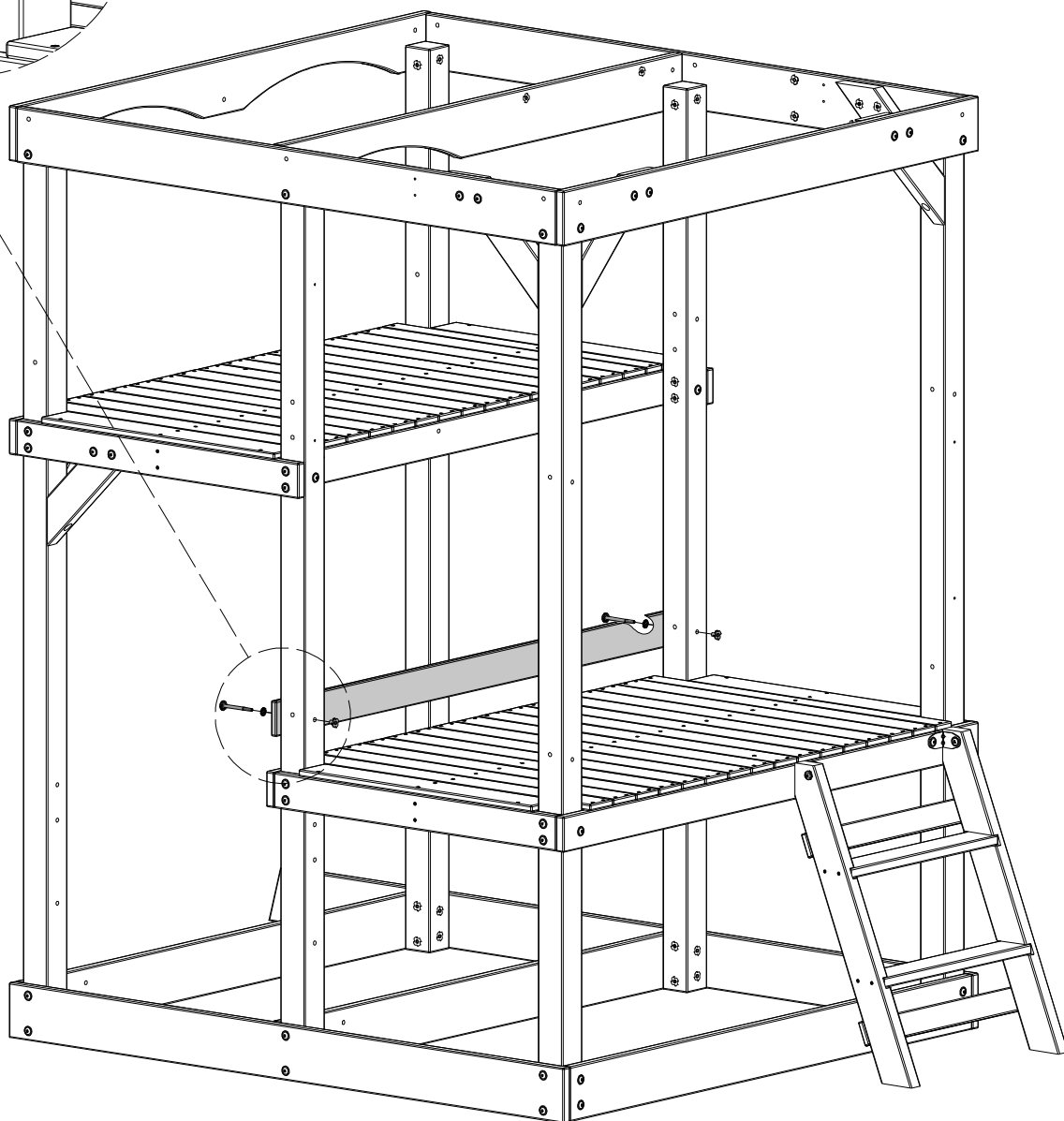
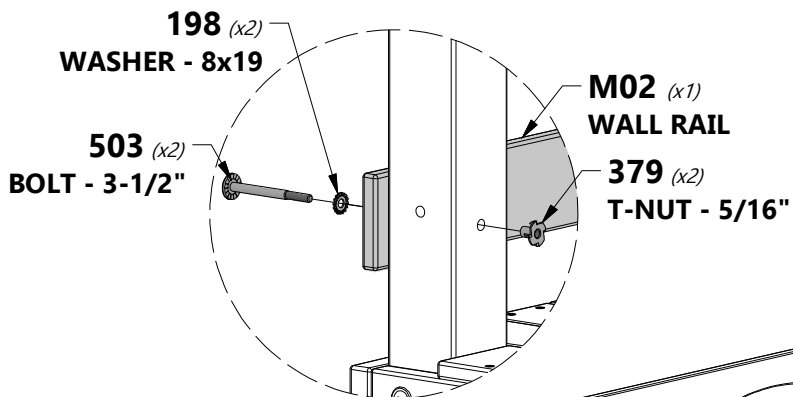



M03 | WALL BOARD - W4L13944
(x1) | 5/8"x3 3/8"x52 3/8" (16x86x1332)

M05 | WALL RAIL - W4L13949
(x1) | 5/8"x3 3/8"x33 1/4" (16x86x844)

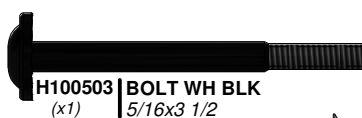

H100379 | T-NUT BLK
(x2) | 5/16

H100198 | WASHER LOCK EXT BLK
(x2) | 8x19



NOTE:
START BY ASSEMBLING M03 & M05 BOARDS AS SHOWN. THEN MOUNT M05 TO POST USING A SQUARE AND/OR THE DIMENSIONS BELOW TO ENSURE CORRECT PLACEMENT AND INSTALL WITH SCREWS AS SHOWN.

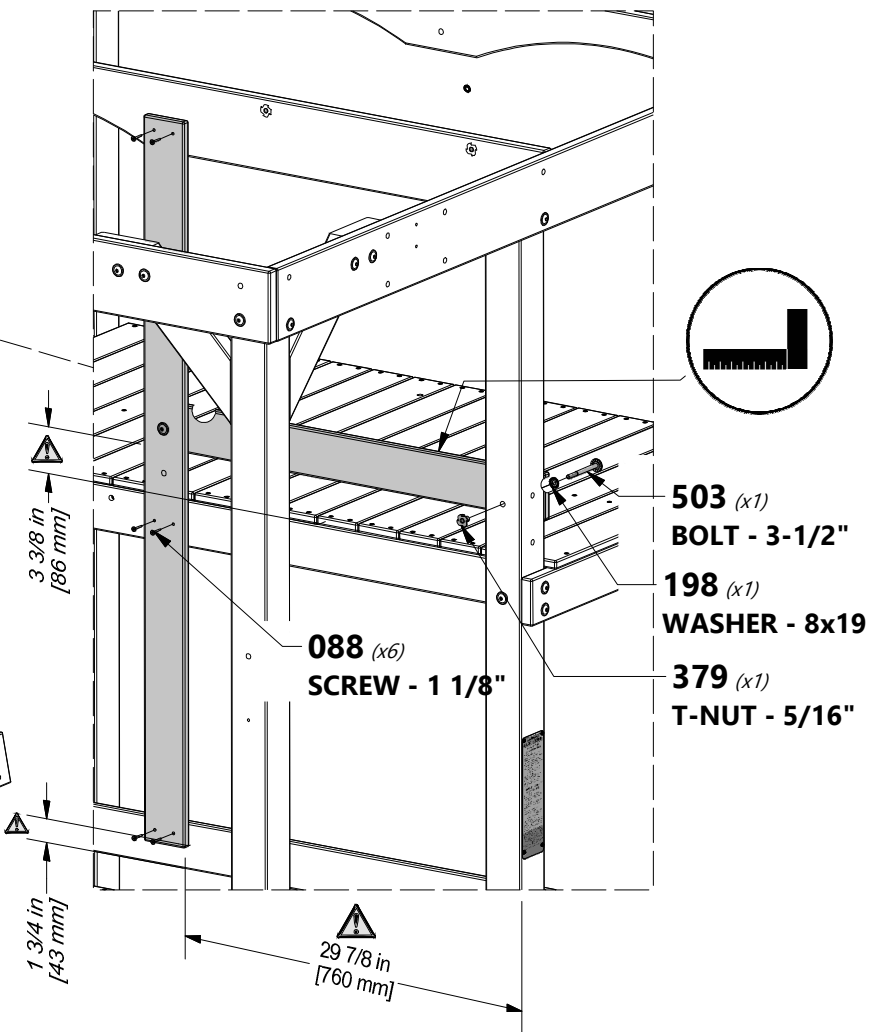
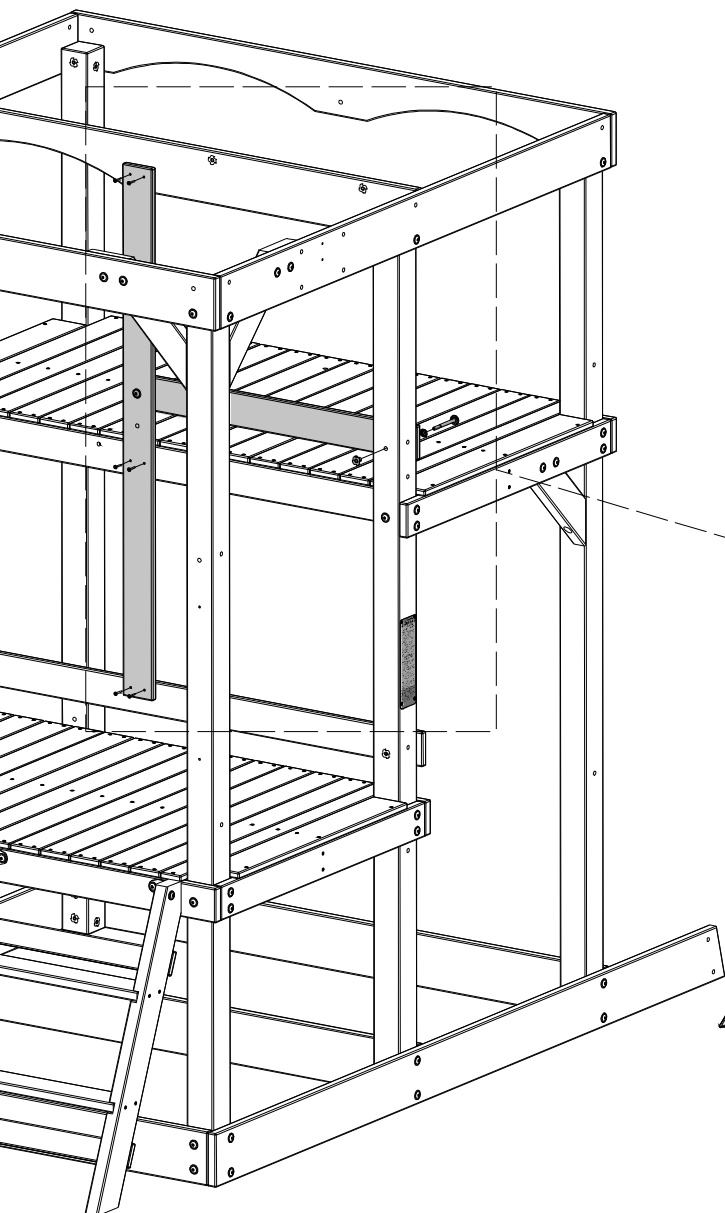
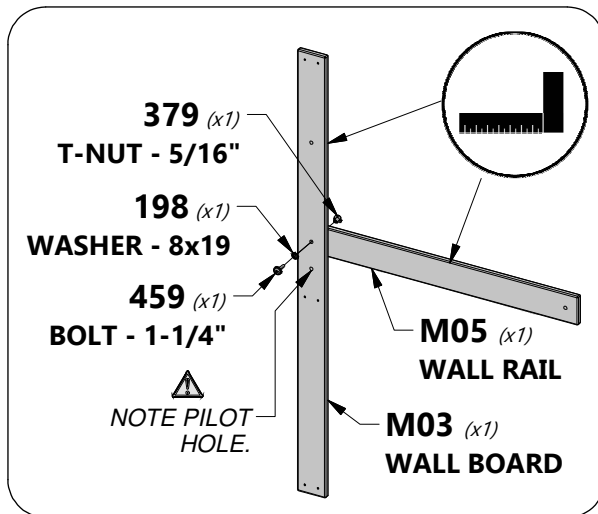

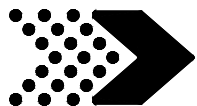

FORT ASSEMBLY

STEP 12

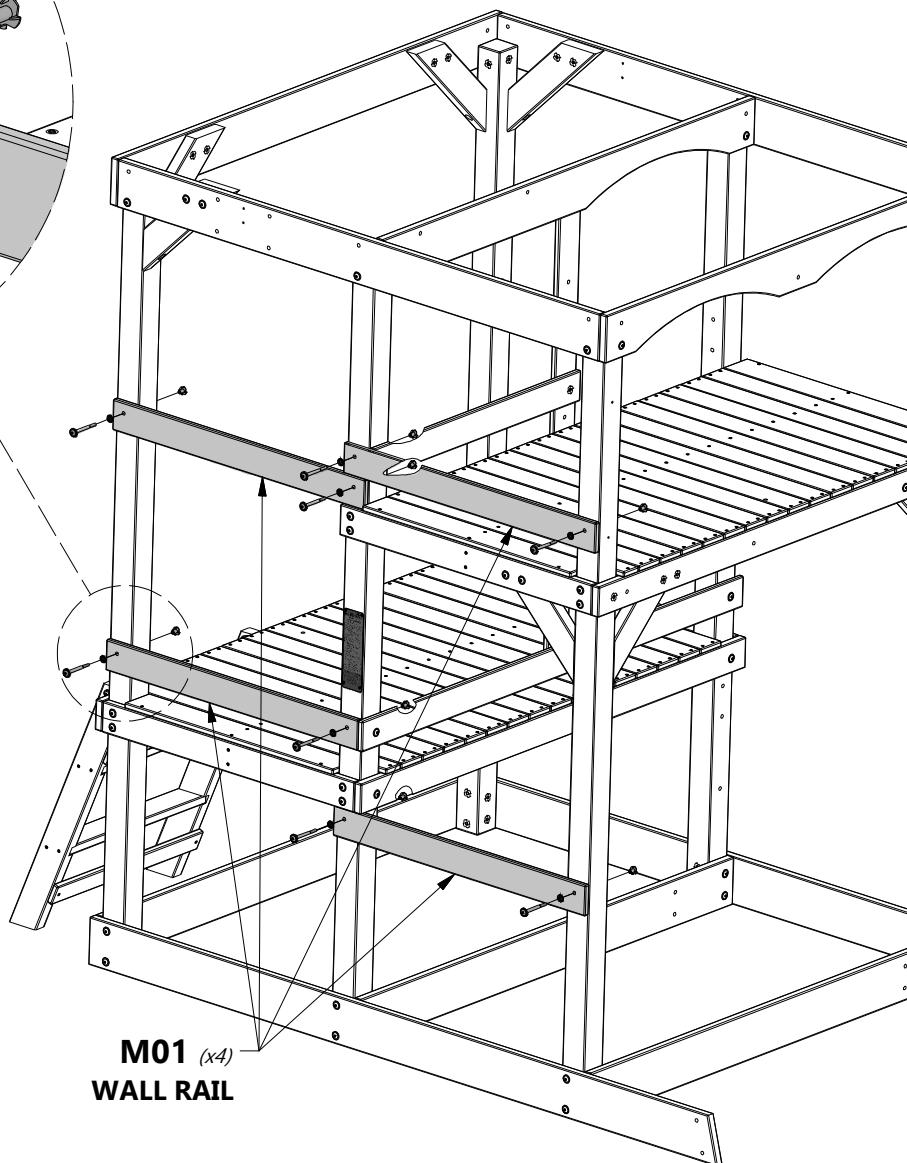
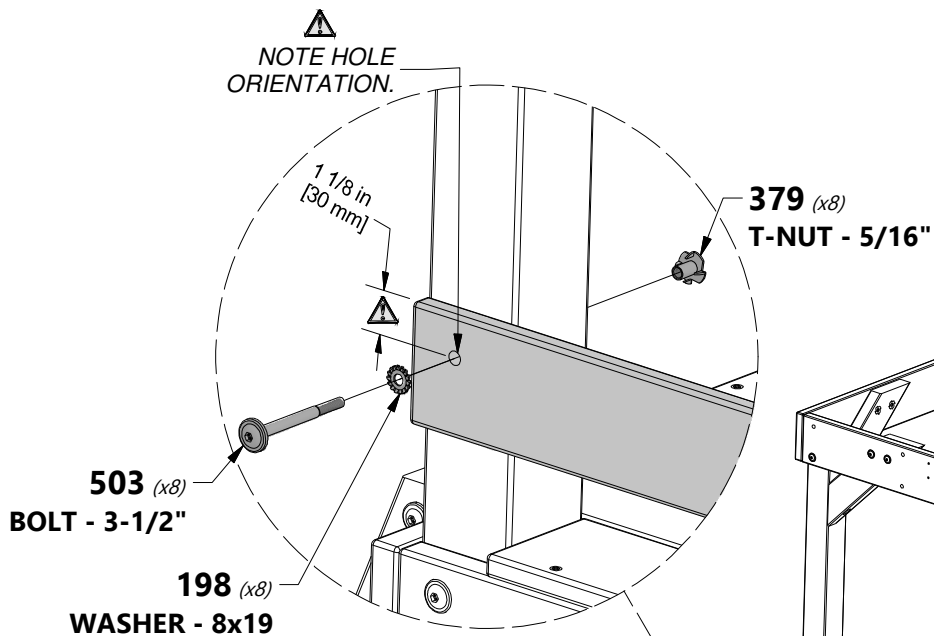
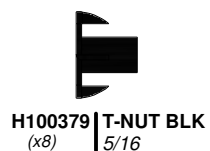
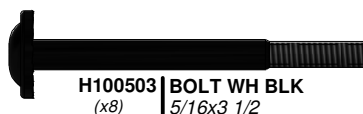
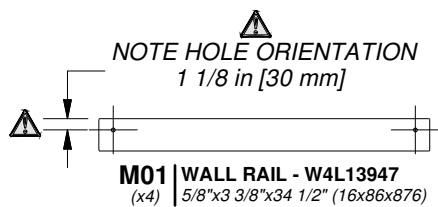

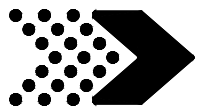

FORT ASSEMBLY

STEP 13

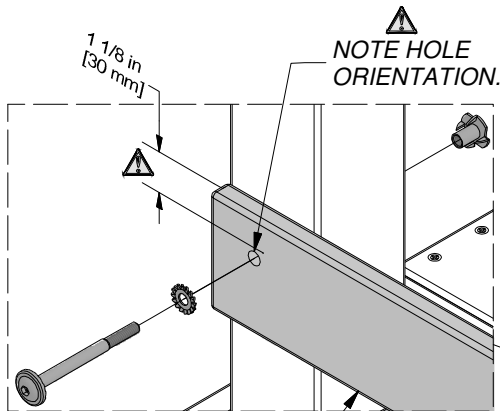
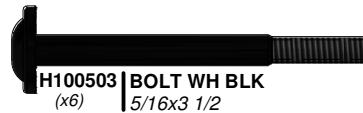
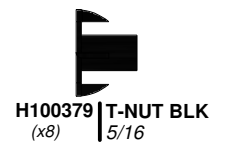
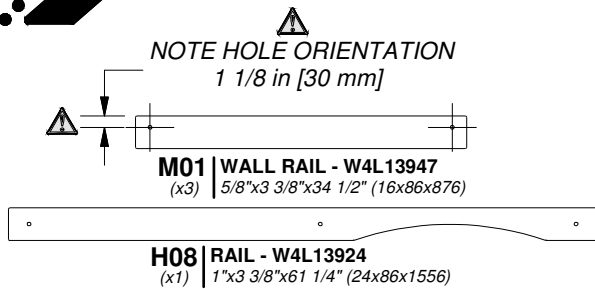

M01 (x1)
WALL RAIL

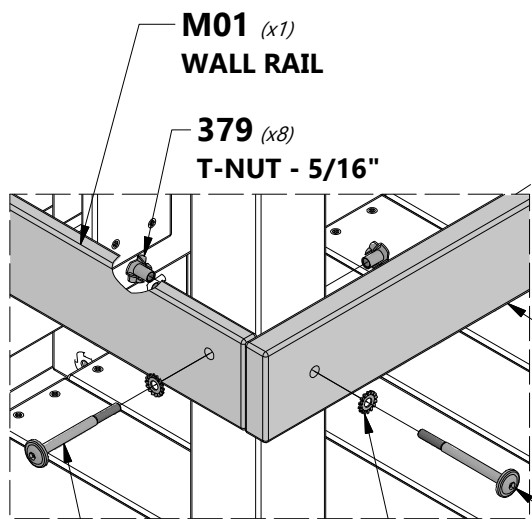
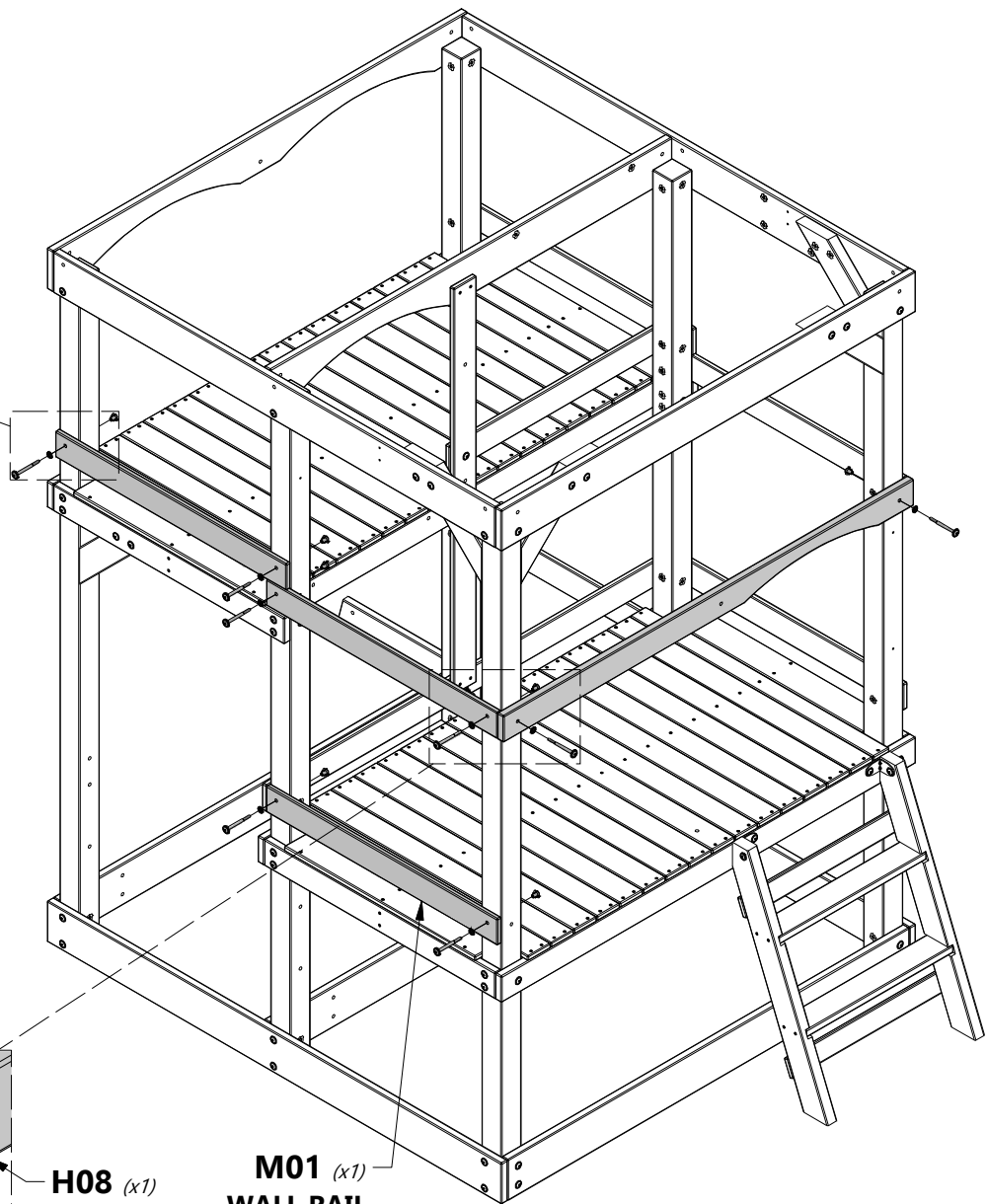

503 (x6)
BOLT - 3-1/2"

198 (x8)
WASHER - 8x19

H08 (x1)
RAIL

415 (x2)
BOLT - 3-3/4"

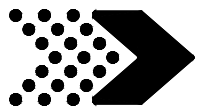

FORT ASSEMBLY

STEP 14

M04 | WALL RAIL - W4L13946
(x1) | 5/8"x3 3/8"x34 1/8" (16x86x868)

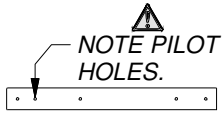

H10 | RAIL - W4L13934
(x1) | 1"x3 3/8"x32 3/4" (24x86x833)



H11 | RAIL - W4L13937
(x1) | 1"x3 3/8"x26 7/8" (24x86x681)

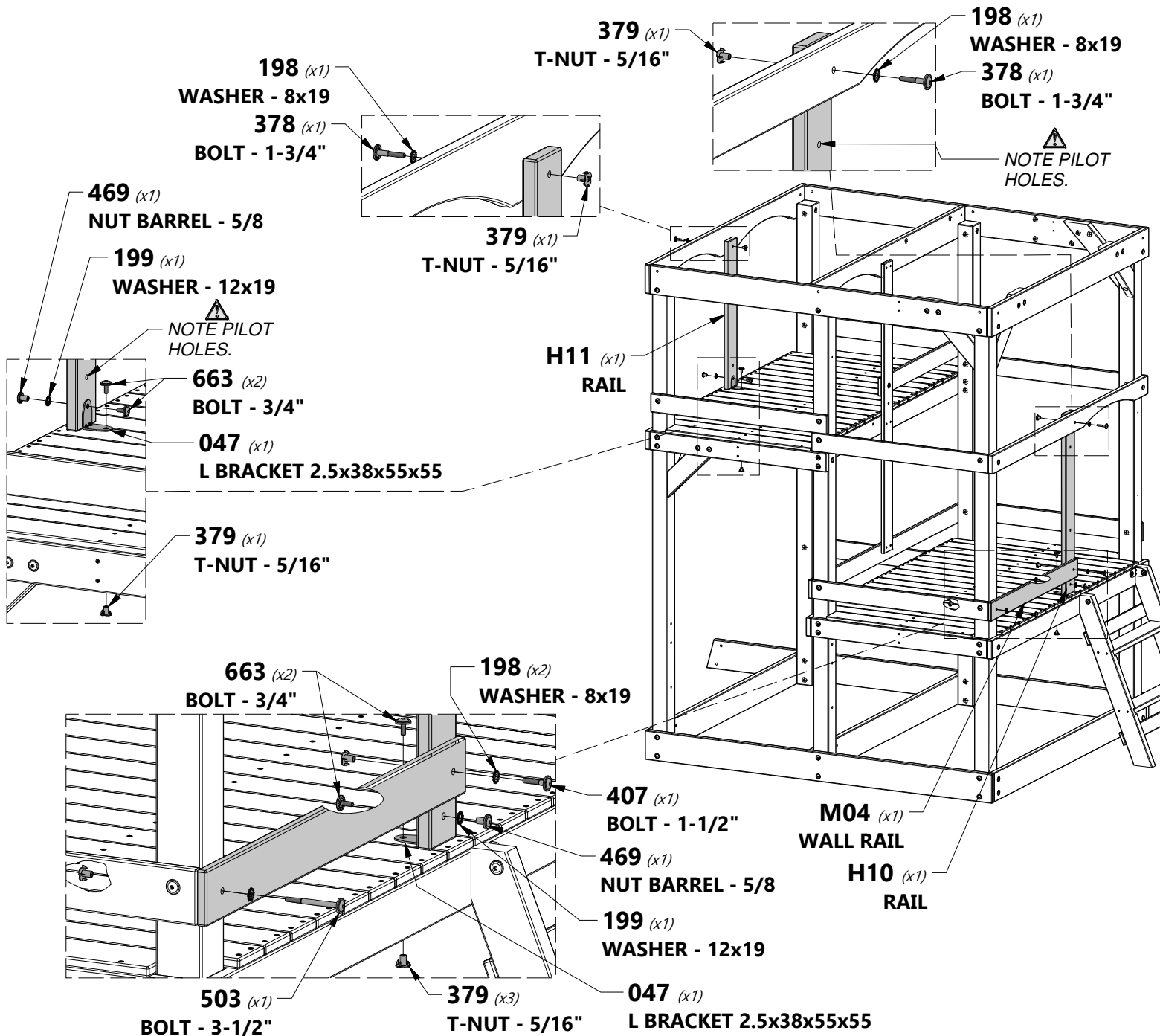
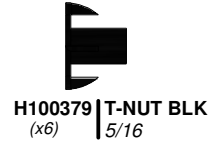
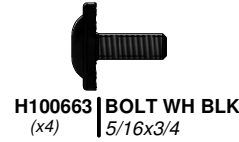
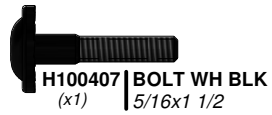
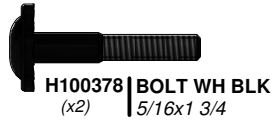

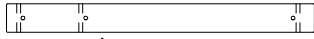
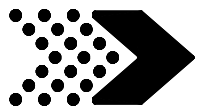

B07 | POST - W4L13903
(x1) | 3"x3"x32" (76x76x814)



B09 | POST - W4L13904
(x2) | 3"x3"x32" (76x76x814)

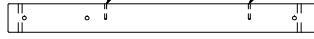

B08 | POST - W4L13975
(x1) | 3"x3"x32" (76x76x814)

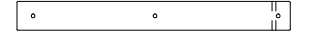

B10 | POST - W4L13905
(x2) | 3"x3"x28 1/2" (76x76x724)



N07 | UPPER WALL RAIL - W4L13919
(x1) | 5/8"x2 3/8"x60" (16x60x1524)

NOTE PILOT HOLES.



H100415 | BOLT WH BLK
(x12) | 5/16x3 3/4

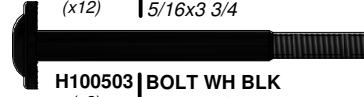

H100503 | BOLT WH BLK
(x2) | 5/16x3 1/2



H100379 | T-NUT BLK
(x14) | 5/16



H100198 | WASHER LOCK EXT BLK
(x14) | 8x19



NOTE:
USE THE PILOT HOLES TO ORIENTATE EACH POST AND ASSEMBLE AS SHOWN.

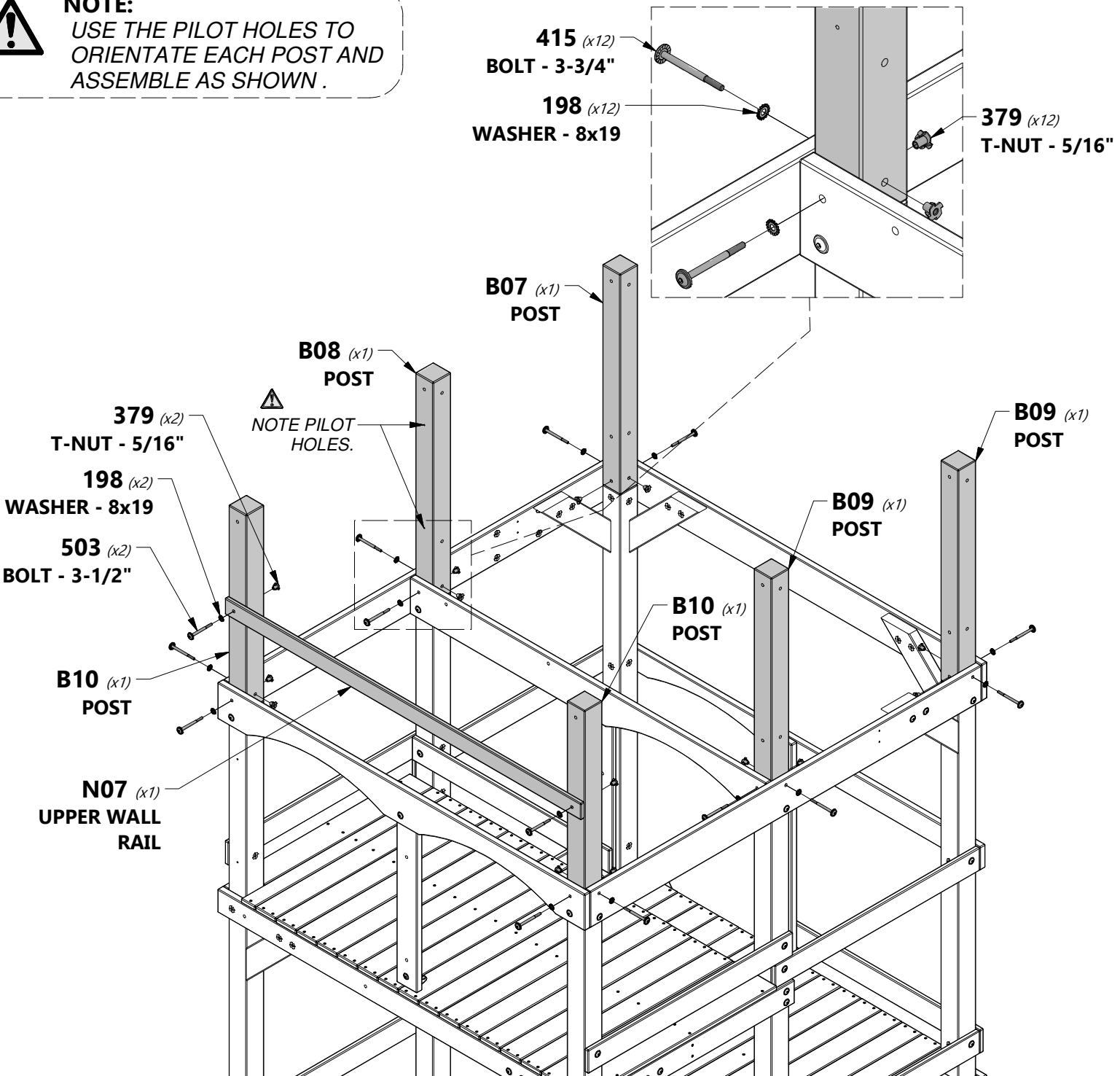

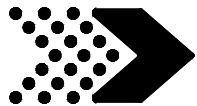

FORT ASSEMBLY

STEP 16

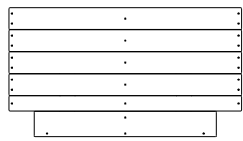

HH1 | FLOOR PANEL - W2A03079
(x1) | 1 1/4"x20 1/8"x36 3/8" (32x510x924)

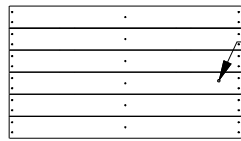

HH7 | FLOOR PANEL - W2A03087
(x1) | 36 3/8"x1 1/4"x20 9/16" (924x32x522)

 **NOTE PILOT HOLE.**

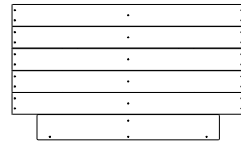

HH3 | FLOOR PANEL - W2A03078
(x1) | 36 3/8"x1 1/4"x21 1/8" (924x32x536)



H04 | RAIL - W4L13928
(x1) | 1"x3 3/8"x60" (24x86x1524)

 **H100201** | SCREW PFH BLK
(x4) | 8x2-1/2

 **H100086** | SCREW PFH
(x86) | 8x1 1/2

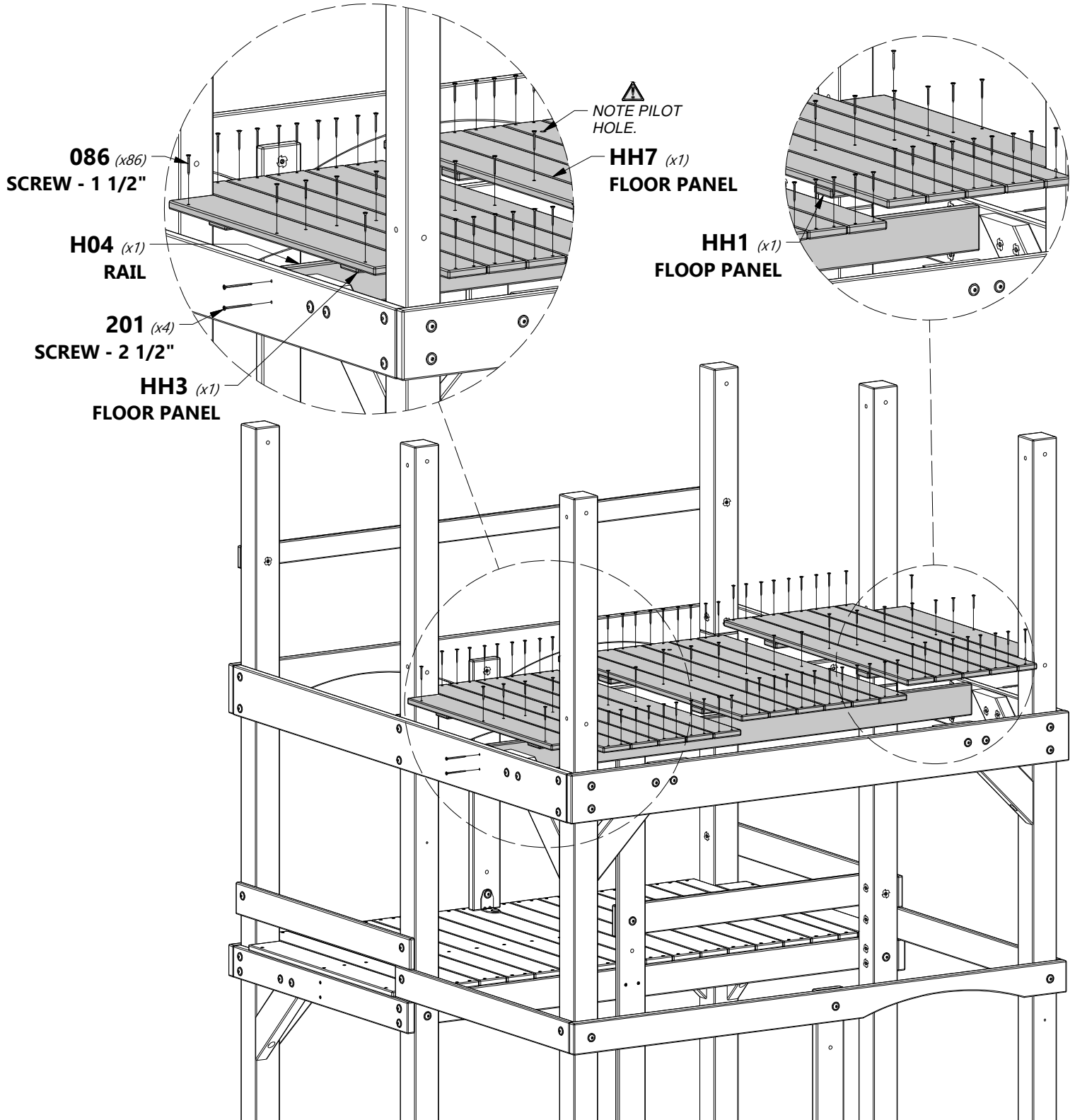

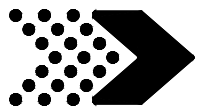

FORT ASSEMBLY

STEP 17

M01 | WALL RAIL - W4L13947
(x4) | 5/8"x3 3/8"x34 1/2" (16x86x876)

H13 | RAIL - W4L13923
(x1) | 1"x3 3/8"x66" (24x86x1676)

H100503 | BOLT WH BLK
(x10) | 5/16x3 1/2

H100379 | T-NUT 5/16 BLK
(x14)

M02 | WALL RAIL - W4L13943
(x1) | 5/8"x3 3/8"x61 1/4" (16x86x1556)

H14 | RAIL - W4L13922
(x1) | 1"x3 3/8"x66" (24x86x1676)

H100415 | BOLT WH BLK
(x4) | 5/16x3 3/4

H100198 | WASHER LOCK
(x14) | EXT 8x19 BLK

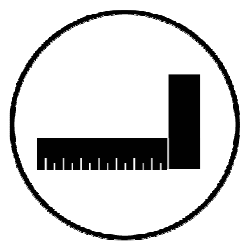

NOTE:
REPEAT THIS ON BOTH
SIDES WHERE SHOWN.

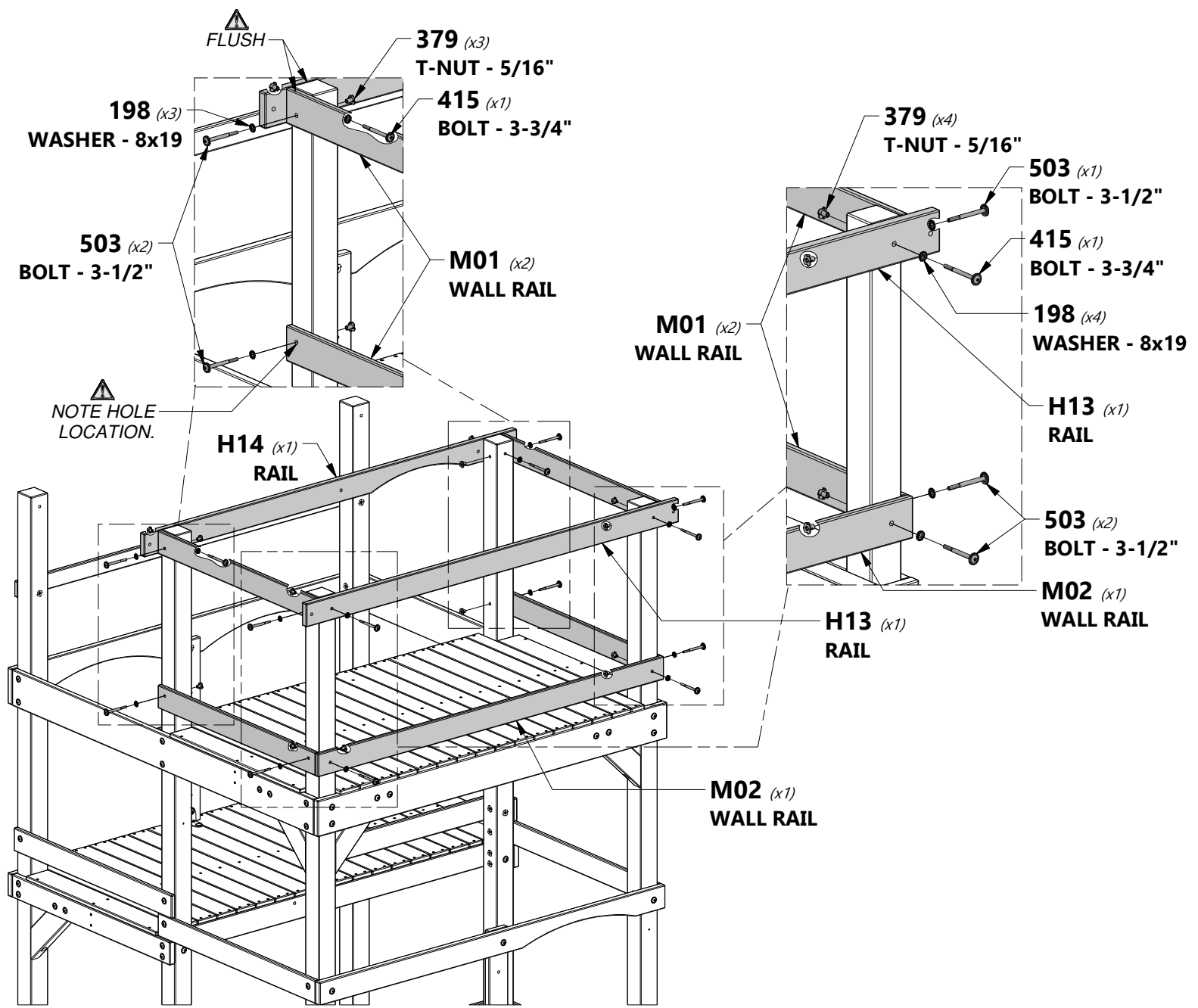

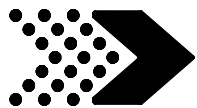

FORT ASSEMBLY

STEP 18

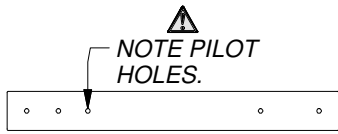

H18 | RAIL - W4L13935
(x1) | 1"x3 3/8"x28 3/4" (24x86x731)



A4M01047 | L BRACKET
(x1) | 2.5x38x55x55



M04 | WALL RAIL - W4L13946
(x1) | 5/8"x3 3/8"x34 1/8" (16x86x868)

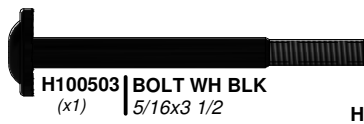

H100503 | BOLT WH BLK
(x1) | 5/16x3 1/2



H100663 | BOLT WH BLK
(x2) | 5/16x3/4



H100378 | BOLT WH BLK
(x1) | 5/16x1 3/4



H100469 | NUT BARREL WH BLK
(x1) | 5/16x5/8



H100198 | WASHER LOCK
(x3) | EXT 8x19 BLK

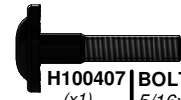

H100407 | BOLT WH BLK
(x1) | 5/16x1 1/2



H100379 | T-NUT BLK
(x4) | 5/16



H100199 | WASHER LOCK
(x1) | EXT 12x19 BLK

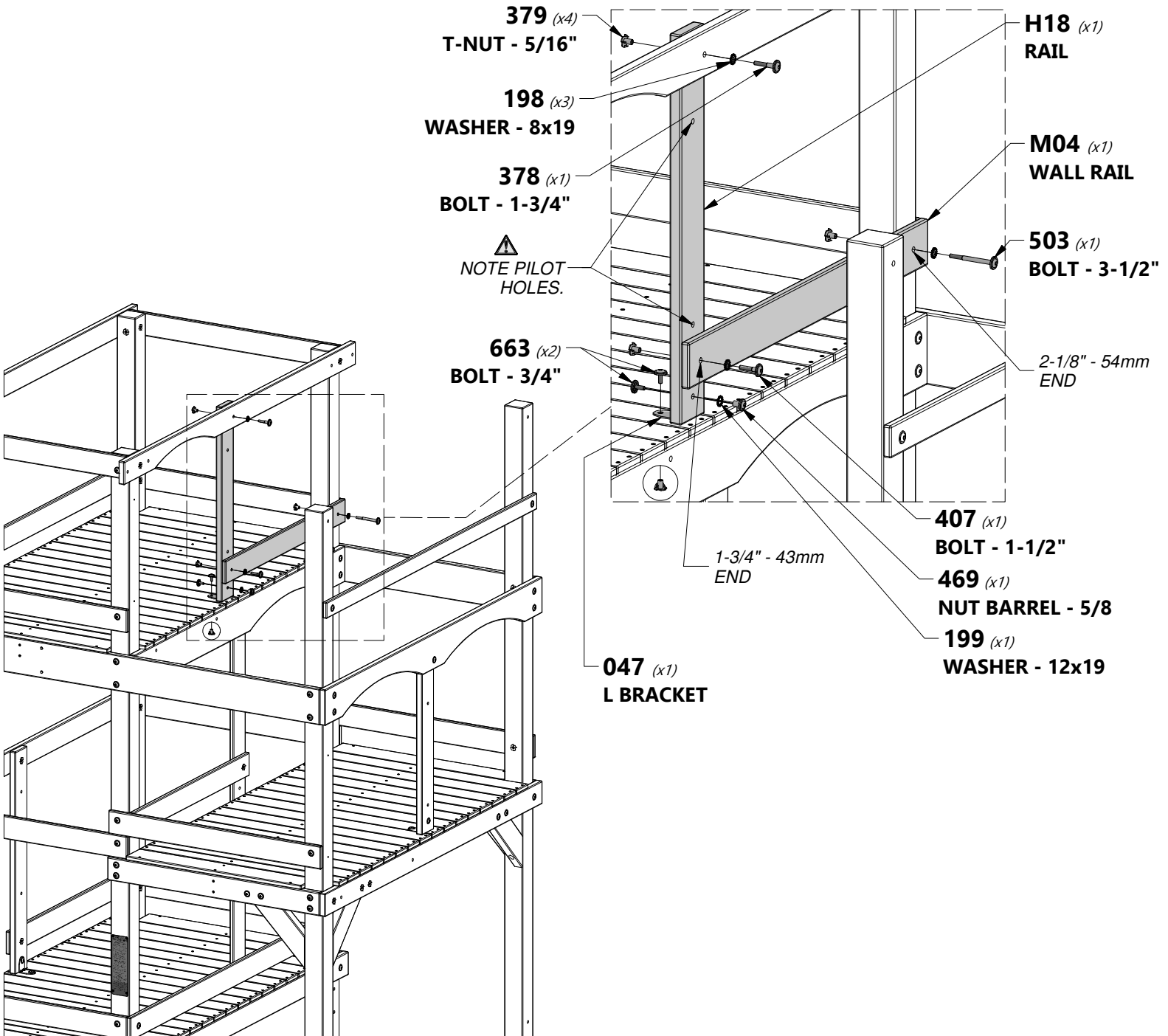

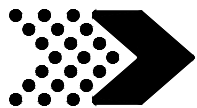

N03 GABLE BOARD - W4L13956
(x2) 5/8"x2 3/8"x34" (16x60x864)

K01 SUNBURST - W4L13914
(x2) 5/8"x5 1/4"x13 1/2" (16x134x344)

H15 RAFTER - W4L13929
(x2) 1"x3 3/8"x49 3/4" (24x86x1262)

H100380 SCREW PFH BLK
(x26) 8x1 1/8

N08 GABLE BOARD - W4L13961
(x2) 5/8"x2 3/8"x16" (16x60x406)

N09 GABLE BOARD - W4L13962
(x4) 5/8"x2 3/8"x10" (16x60x254)

H17 RAFTER - W4L13930
(x2) 1"x3 3/8"x49 7/8" (24x86x1268)

COMPLETE THIS TWICE TO MAKE TWO SUNBURST ASSEMBLIES

NOTE: INSTALL N09 BOARDS AT APPROXIMATELY 45° AS SHOWN.

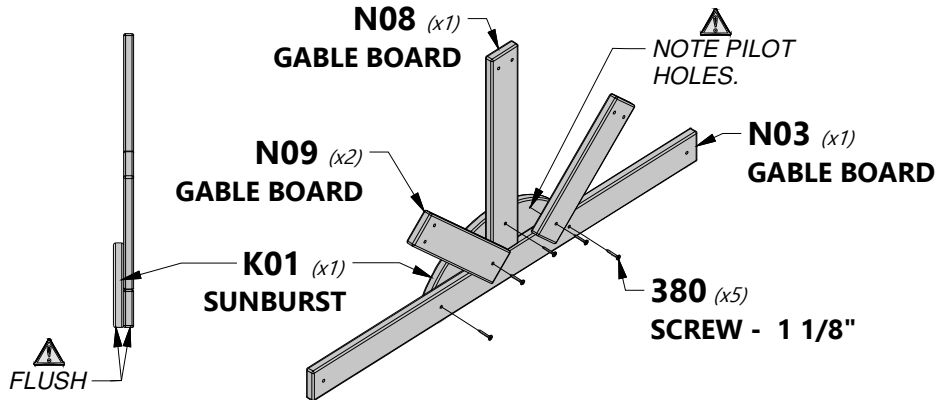
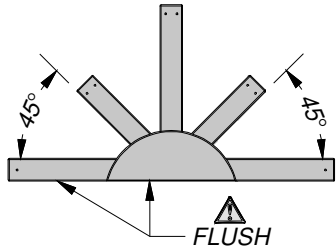

NOTE: ASSEMBLE BOTH GABLE PANELS AS SHOWN. USE THE DIMENSIONS BELOW TO PLACE THE SUNBURST ASSEMBLIES AND ENSURE THERE'S A GAP ON ALL SIDES OF THE SUNBURST ASSEMBLIES AS SHOWN.

UPPER GABLE ASSEMBLY

LOWER GABLE ASSEMBLY

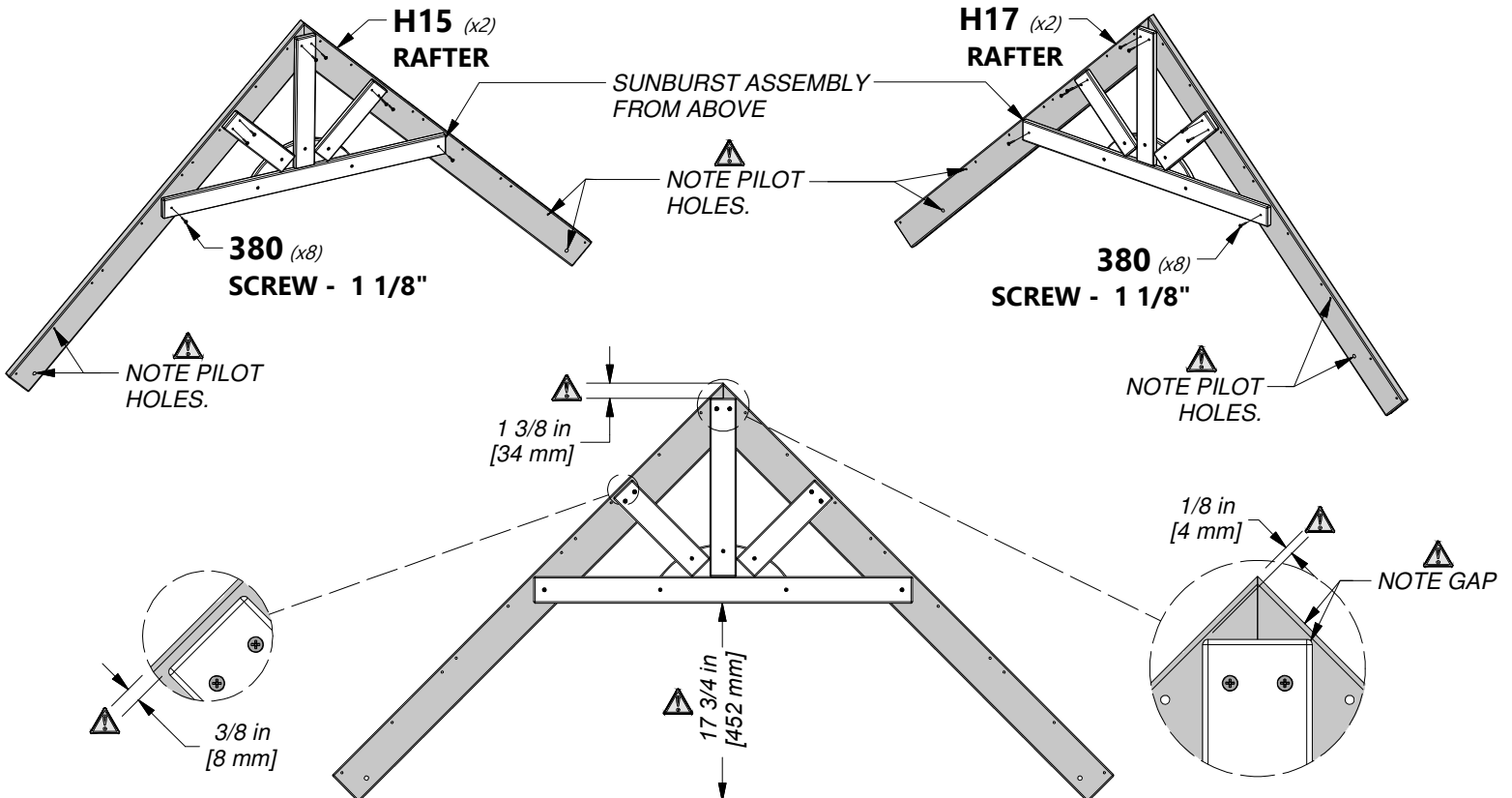

NOTE: BOTH GABLE ASSEMBLIES WILL BE USED IN A LATER STEP.

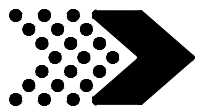

FORT ASSEMBLY

STEP 20

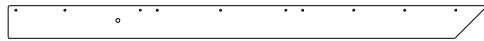

H16 | RAFTER - W4L13931
(x2) | 1"x3 3/8"x49 7/8" (24x86x1268)



N10 | GABLE BOARD - W4L13963
(x1) | 5/8"x2 3/8"x3" (16x60x76)



H100378 | BOLT WH BLK
(x2) | 5/16x1 3/4



H100198 | WASHER LOCK
(x2) | EXT 8x19 BLK



H100379 | T-NUT 5/16 BLK
(x2)



H100087 | SCREW PFH
(x4) | 8x1 1/4



NOTE:

USE THE GABLE ASSEMBLY DIAGRAM TO LOCATE THE N10 BOARD AND INSTALL AS SHOWN.

GABLE ASSEMBLY

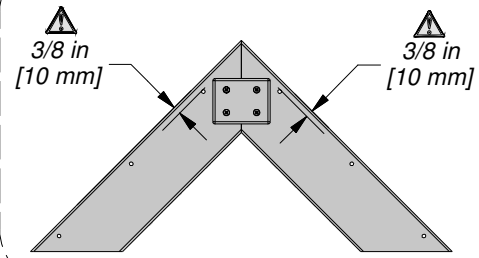

H16 (x2)
RAFTER

N10 (x1)
GABLE BOARD

087 (x4)
SCREW - 1-1/4"

378 (x2)
BOLT - 1-3/4"

198 (x2)
WASHER - 8x19

379 (x2)
T-NUT - 5/16"

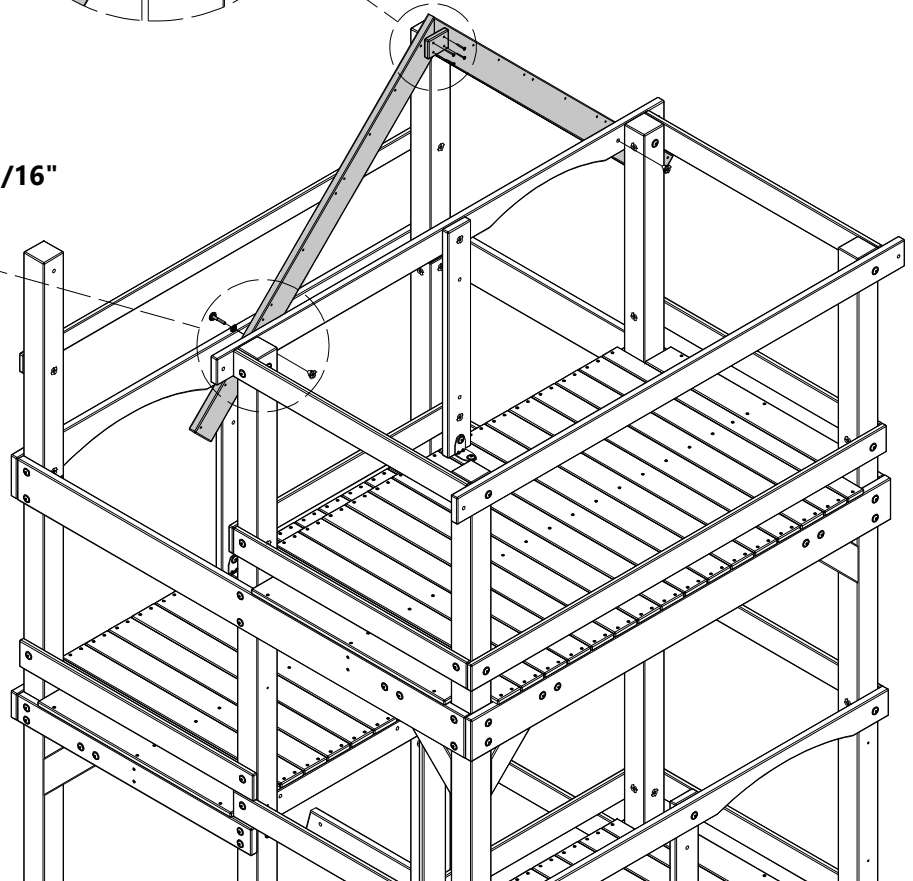

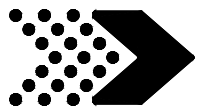

FORT ASSEMBLY

STEP 21

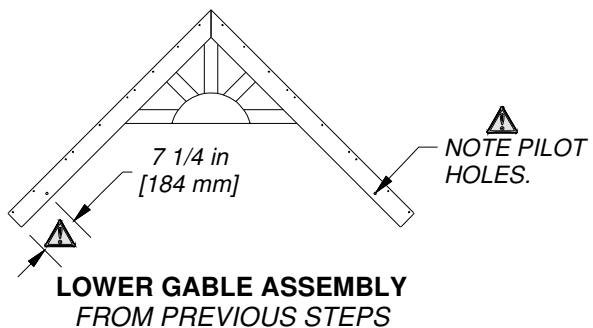

H100198 | WASHER LOCK
(x2) | EXT 8x19 BLK



H100379 | T-NUT 5/16 BLK
(x2)

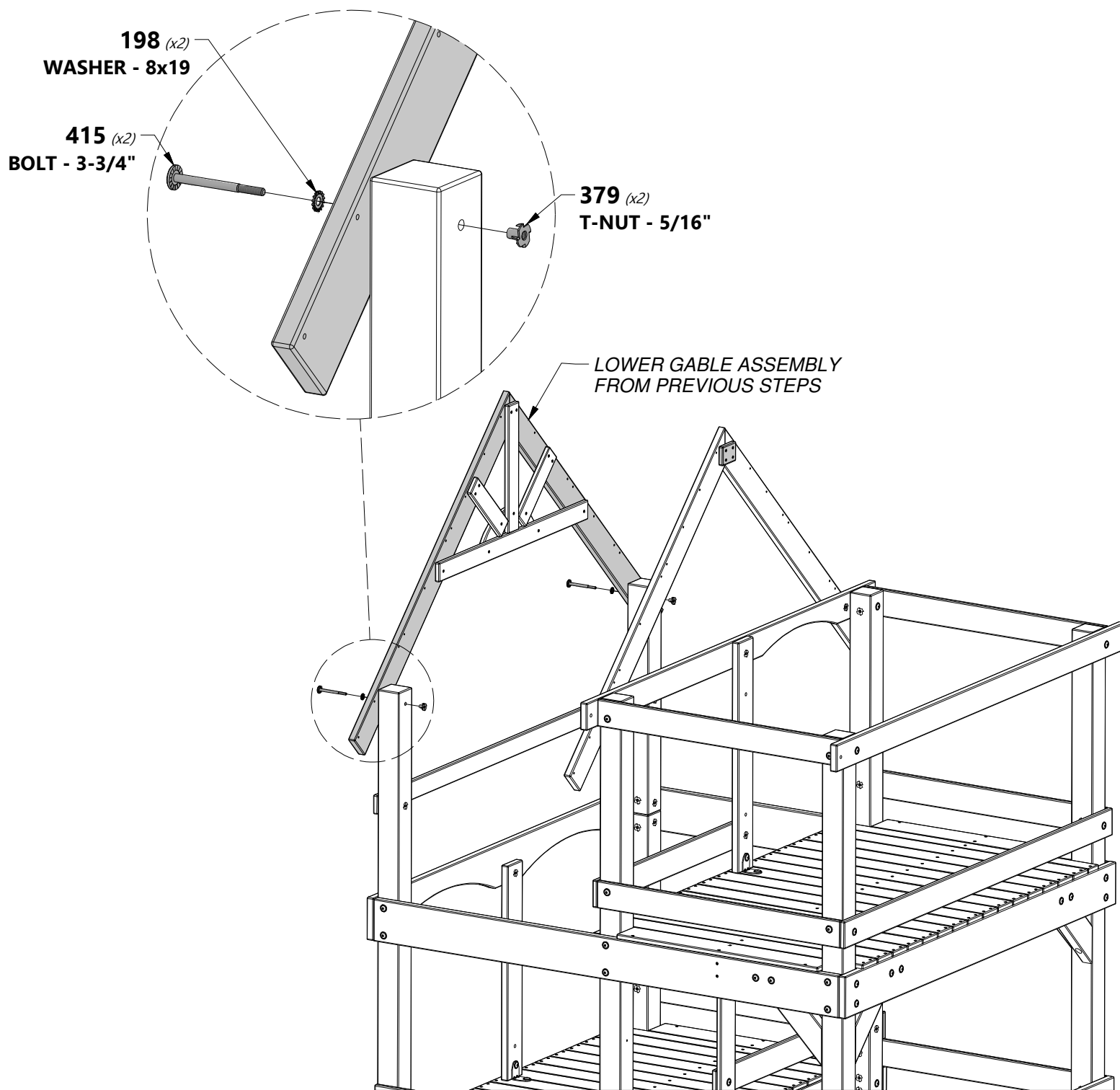

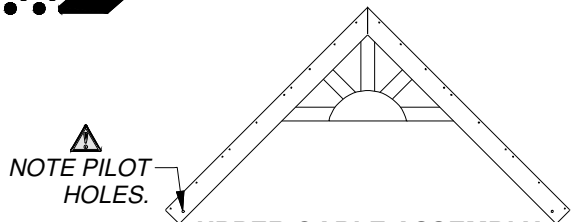

UPPER GABLE ASSEMBLY FROM PREVIOUS STEPS

N10 | GABLE BOARD - W4L13963
(x1) | 5/8"x2 3/8"x3" (16x60x76)

H15 | RAFTER - W4L13929
(x2) | 1"x3 3/8"x49 3/4" (24x86x1262)



H100378 | BOLT WH BLK
(x4) | 5/16x1 3/4



H100198 | WASHER LOCK
(x4) | EXT 8x19 BLK



H100379 | T-NUT 5/16 BLK
(x4)



H100087 | SCREW PFH
(x4) | 8x1 1/4



NOTE:
USE THE GABLE ASSEMBLY DIAGRAM TO LOCATE THE N10 BOARD AND INSTALL AS SHOWN.

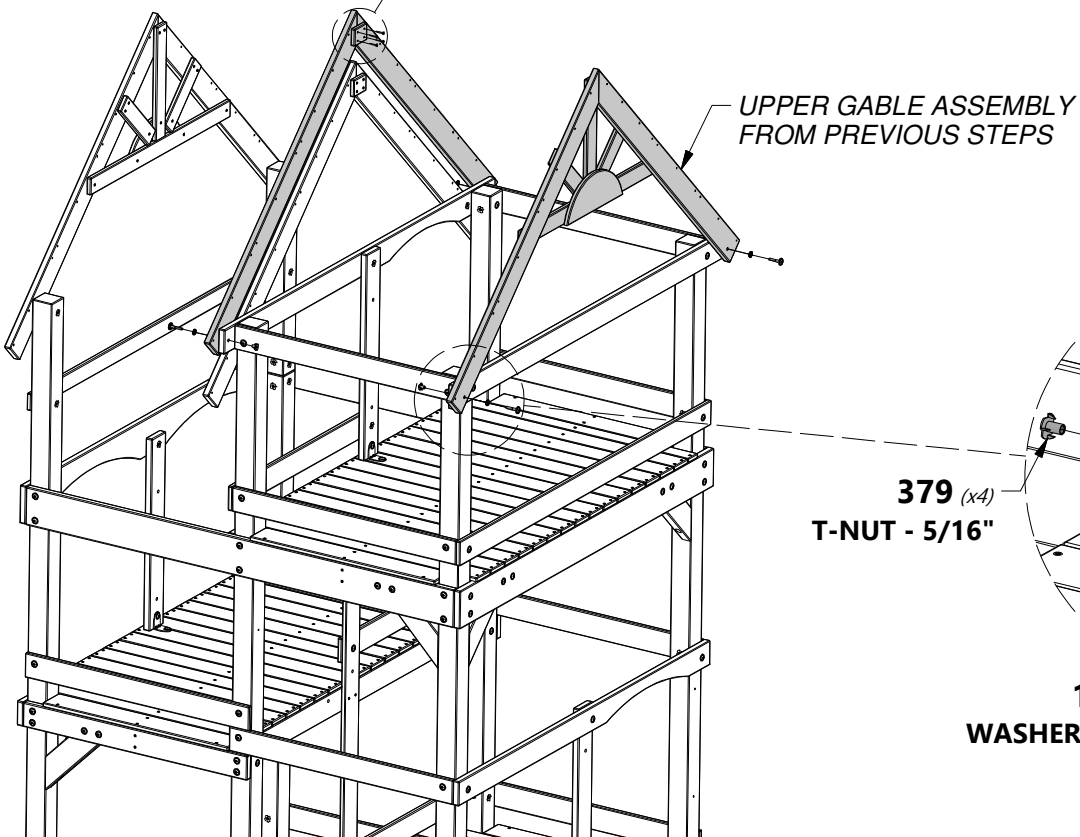
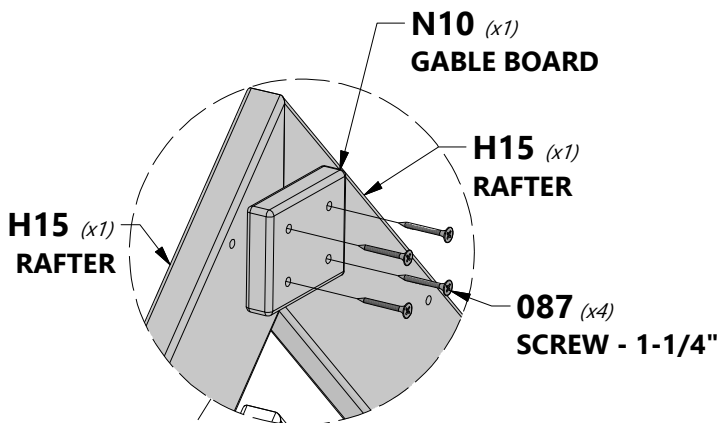
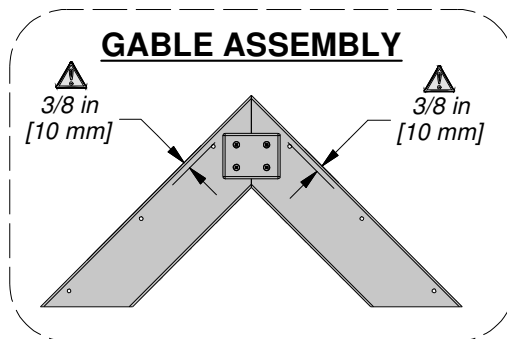

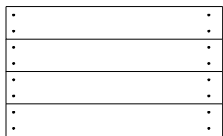
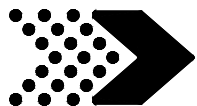

RP7 | ROOF PANEL - W2A03085
(x1) | 1 5/8"x20 11/16"x33 7/8" (42x526x860)



RP8 | ROOF PANEL - W2A03086
(x1) | 1 5/8"x15 5/8"x33 7/8" (42x397x860)



RP9 | ROOF PANEL - W2A03073
(x1) | 1 5/8"x15 5/8"x33 7/8" (42x397x860)



H100111 | SCREW PFH
(x20) | 8x2



NOTE:

START AT THE TOP WITH THE RP7 PANEL AND WORK YOUR WAY DOWN INSTALLING EACH PANEL AS SHOWN.

NOTE PILOT HOLES.

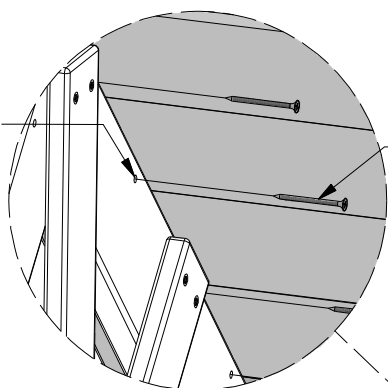

111 (x10)
SCREW - 2"

NOTE PILOT HOLES.

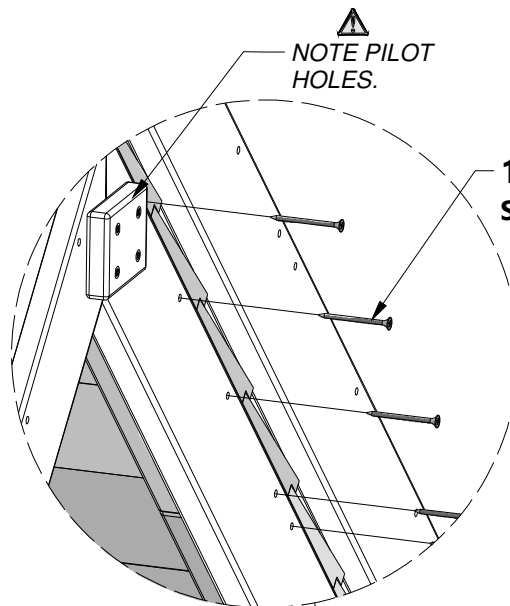

111 (x10)
SCREW - 2"

RP7 (x1)
ROOF PANEL

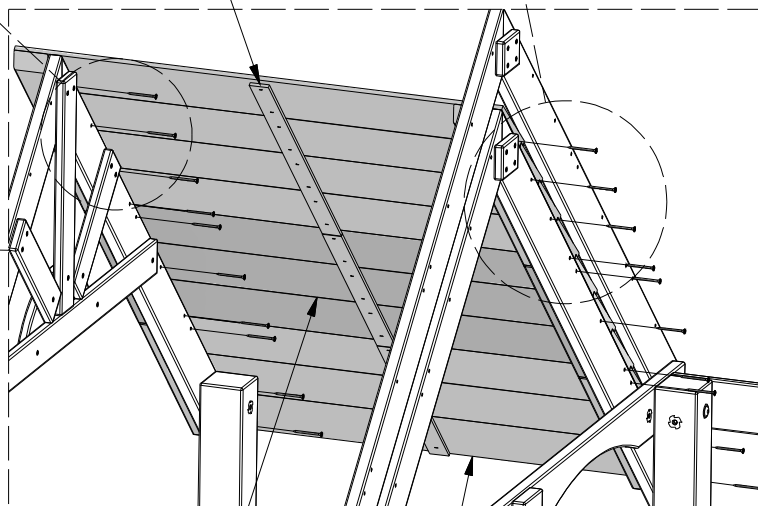

RP8 (x1)
ROOF PANEL

RP9 (x1)
ROOF PANEL

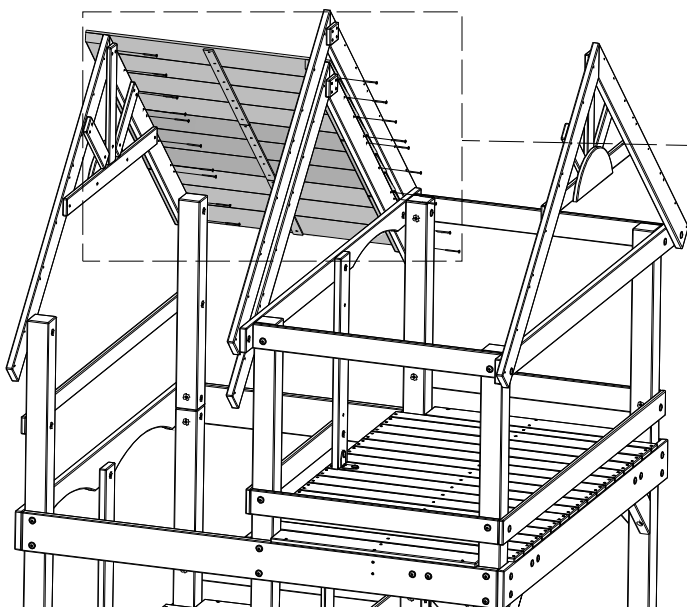

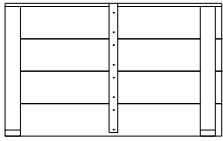
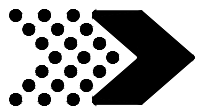

RP4 | ROOF PANEL - W2A03083
(x1) | 33 7/8"x1 5/8"x20 11/16" (860x42x526)

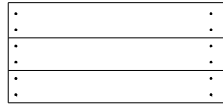

RP5 | ROOF PANEL - W2A03084
(x1) | 1 5/8"x15 5/8"x33 7/8" (42x397x860)

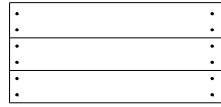

RP6 | ROOF PANEL - W2A03072
(x1) | 1 5/8"x15 5/8"x33 7/8" (42x397x860)



H100111 | SCREW PFH
(x20) | 8x2



NOTE:

START AT THE TOP WITH THE RP4 PANEL AND WORK YOUR WAY DOWN INSTALLING EACH PANEL AS SHOWN.

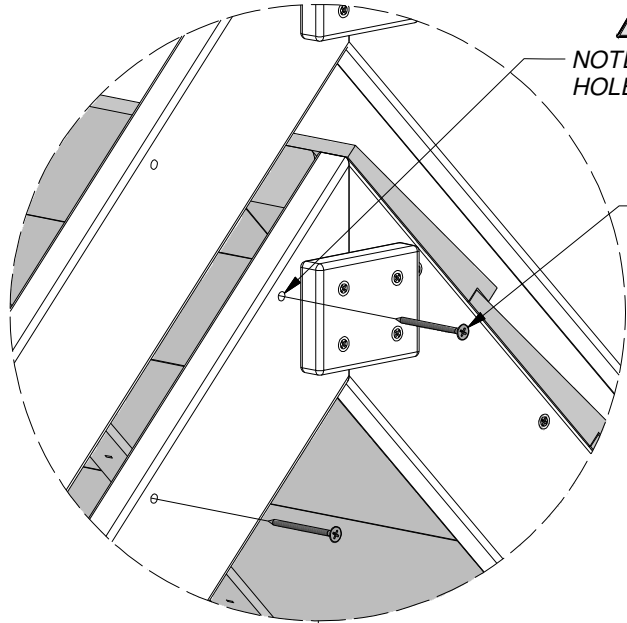

NOTE PILOT HOLES

111 (x20)
SCREW - 2"

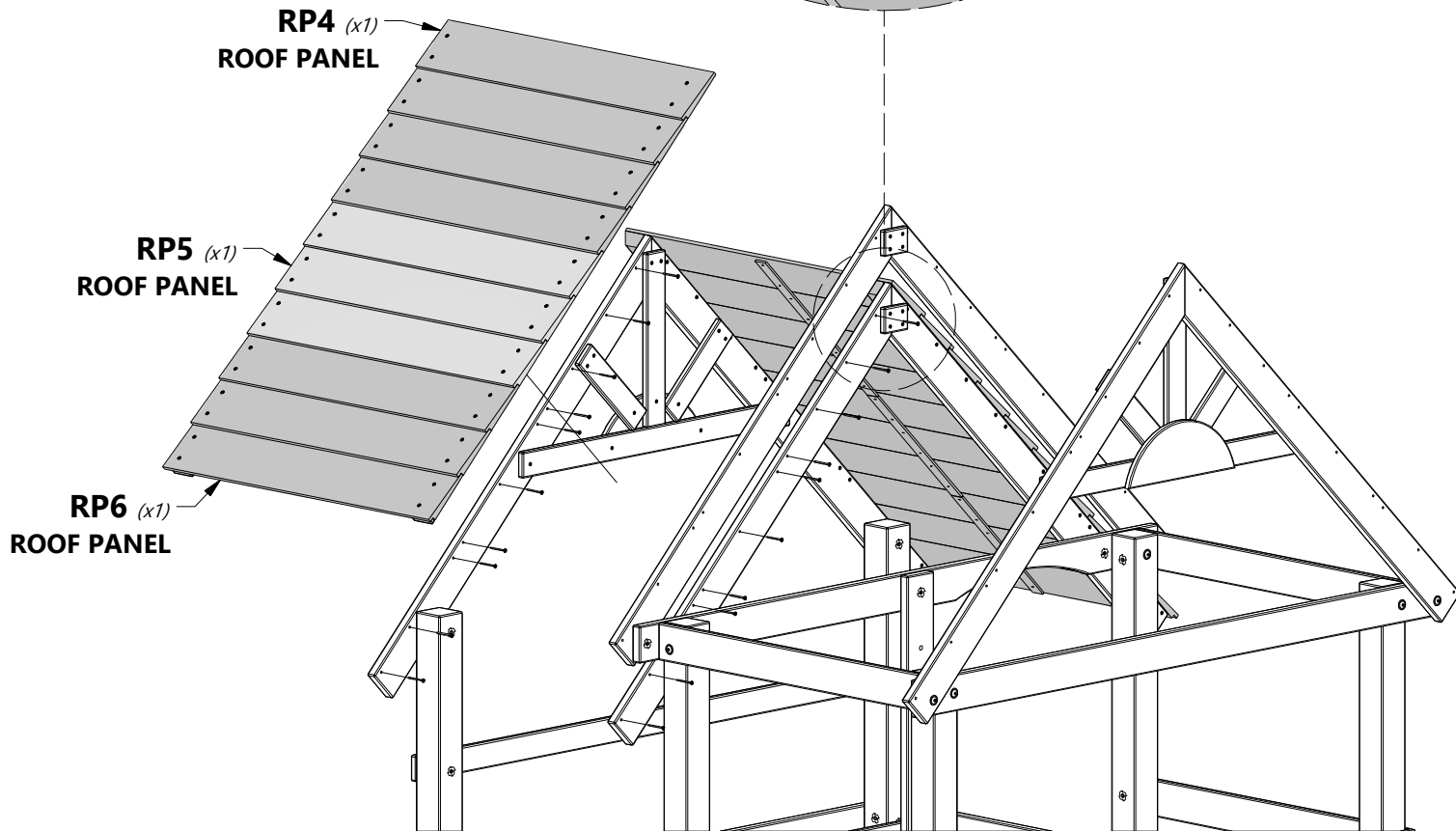

RP4 (x1)
ROOF PANEL

RP5 (x1)
ROOF PANEL

RP6 (x1)
ROOF PANEL

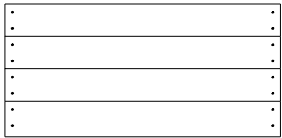
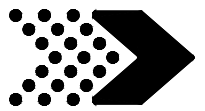

RP1 | ROOF PANEL - W2A03081
(x2) | 1 5/8"x20 11/16"x43 1/16" (42x526x1094)

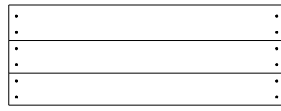

RP2 | ROOF PANEL - W2A03082
(x2) | 1 5/8"x15 5/8"x43 1/16" (41x397x1094)

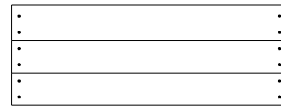

RP3 | ROOF PANEL - W2A03135
(x2) | 1 5/8"x15 5/8"x43 1/16" (41x397x1094)



H100111 | SCREW PFH
(x40) | 8x2



NOTE:

START AT THE TOP WITH THE RP1 PANEL AND WORK YOUR WAY DOWN INSTALLING EACH PANEL AS SHOWN.

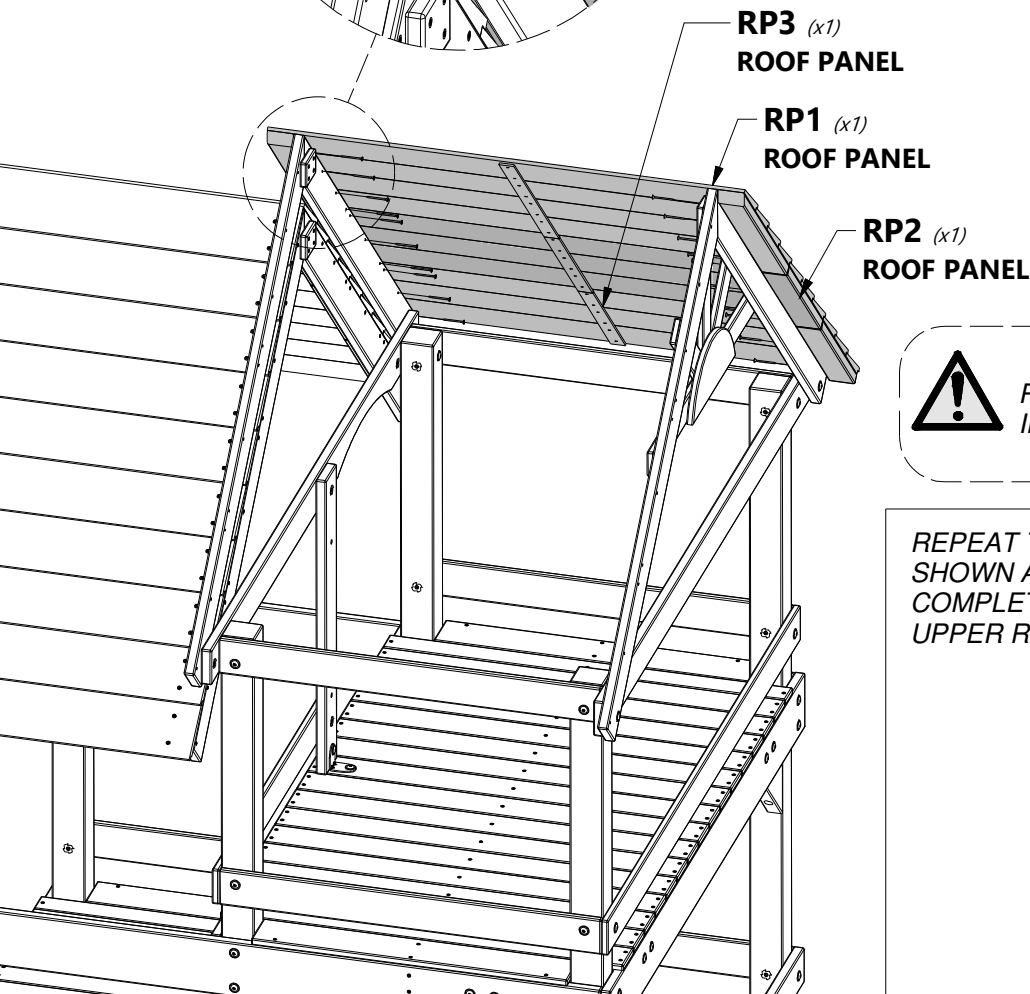
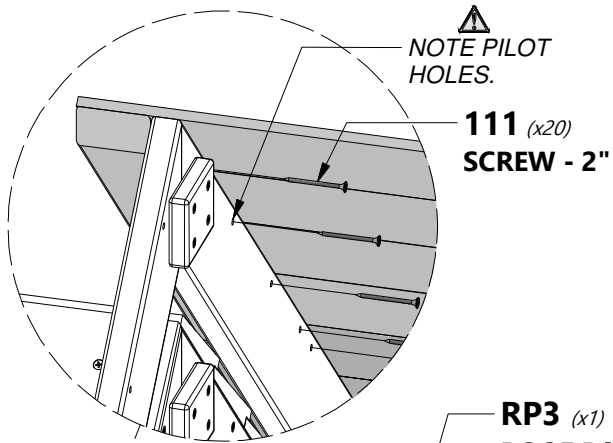

NOTE:

REPEAT THIS STEP TO COMPLETE AND INSTALL TWO ROOF PANEL ASSEMBLIES.

REPEAT THE STEPS SHOWN ABOVE TO COMPLETE THE UPPER ROOF.

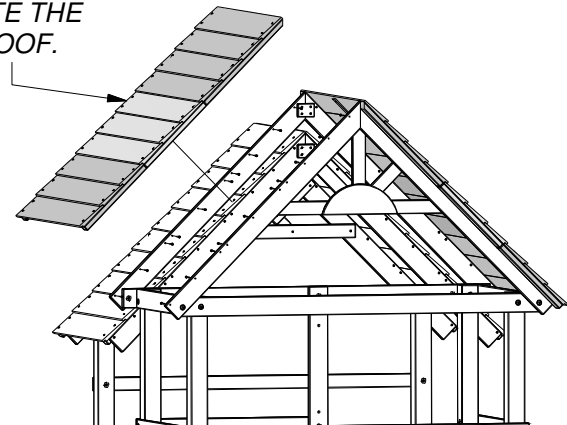

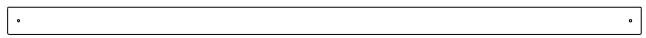
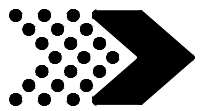

N01 | WALL RAIL - W4L13954
(x2) | 5/8"x2 3/8"x55" (16x60x1398)



H100380 | SCREW PFH BLK
(x4) | 8x1 1/8

FRONT VIEW

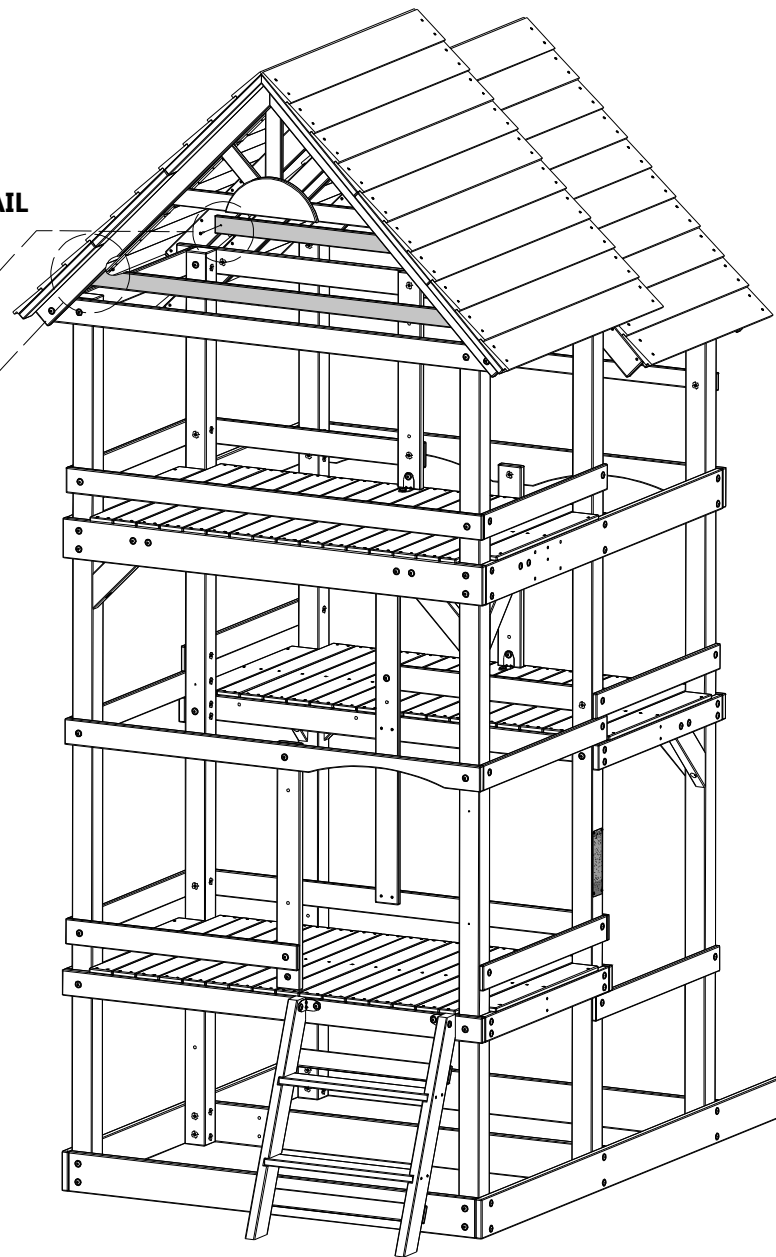
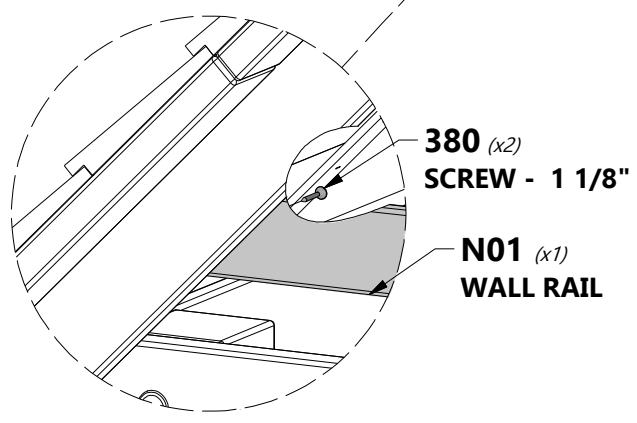
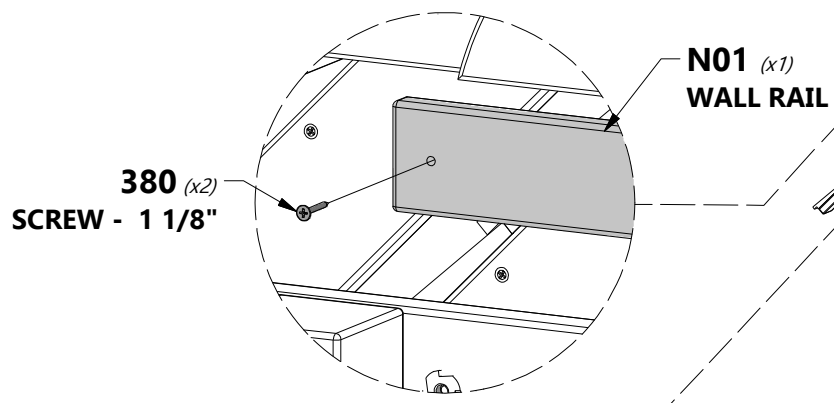
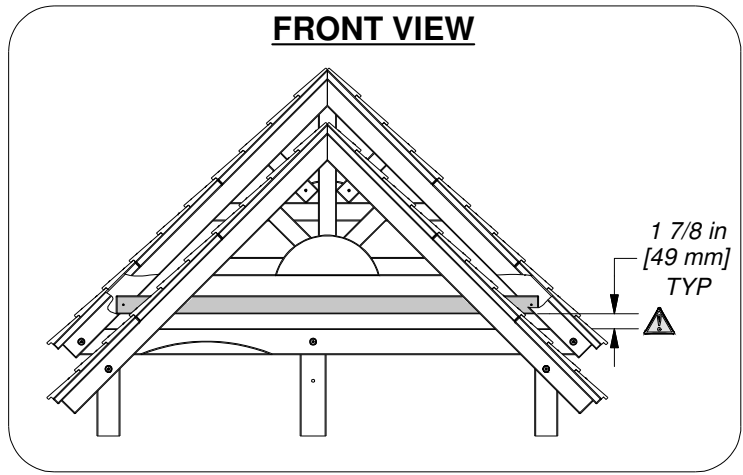

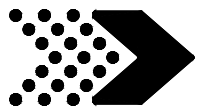

H19 | PICNIC TABLE SEAT - W4L13940
(x2) | 1"x3 3/8"x14 3/4" (24x86x374)

H20 | PICNIC TABLE SEAT SUPPORT - W4L13941
(x2) | 1"x3 3/8"x14 1/2" (24x86x368)

G10 | PICNIC TABLE SUPPORT - W4L13938
(x2) | 1"x5 1/4"x13 1/2" (24x134x344)

M08 | PICNIC TABLE - W4L13950
(x4) | 5/8"x3 3/8"x28 1/2" (16x86x724)

N06 | PICNIC TABLE SUPPORT - W4L13959
(x1) | 5/8"x2 3/8"x12 3/8" (16x60x314)

H12 | BENCH - W4L13933
(x2) | 1"x3 3/8"x32 1/2" (24x86x824)

H100415 | BOLT WH BLK
(x6) | 5/16x3 3/4

H100379 | T-NUT 5/16 BLK
(x14)

H100089 | SCREW PFH
(x24) | 8x1 3/4

H100378 | BOLT WH BLK
(x8) | 5/16x1 3/4

H100198 | WASHER LOCK
(x14) | EXT 8x19 BLK

H100088 | SCREW PFH
(x4) | 8x1 1/8

TABLE TOP ASSEMBLY

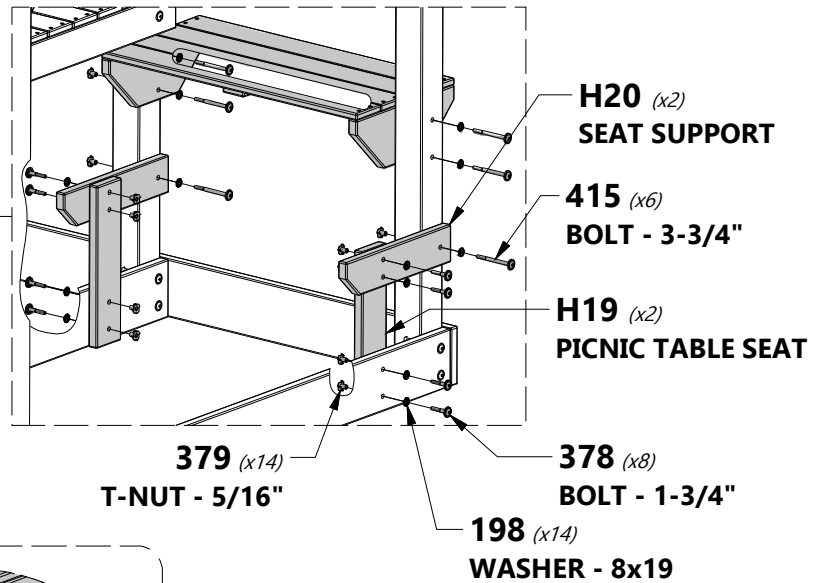
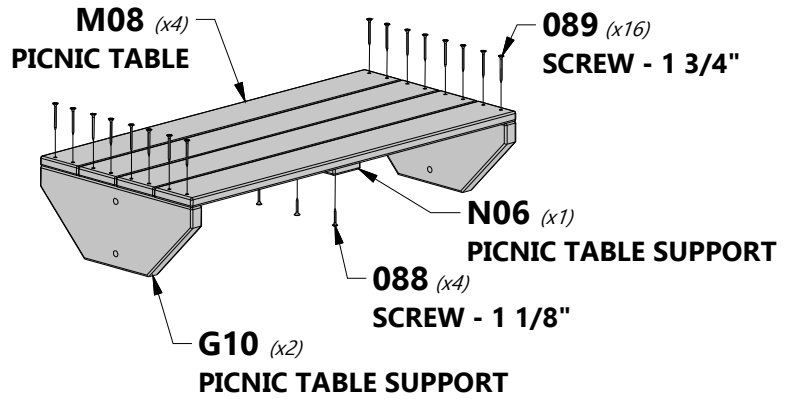

BENCH ASSEMBLY

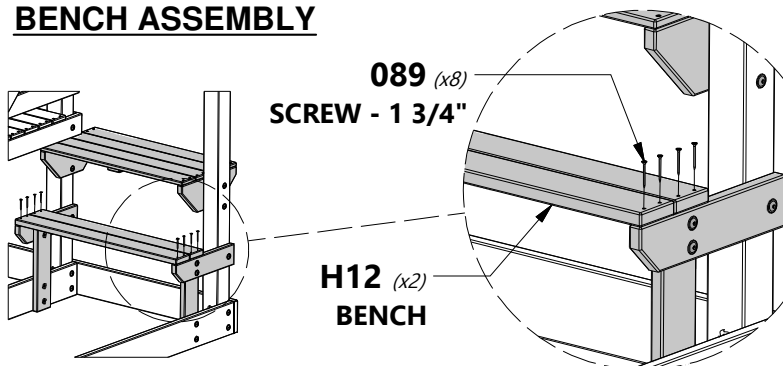

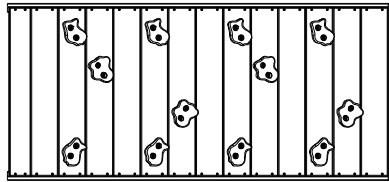
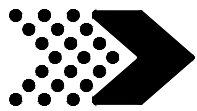

ROCK WALL ASSEMBLY
FROM PREVIOUS STEPS

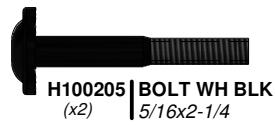

H100205 | BOLT WH BLK
(x2) | 5/16x2-1/4



H100379 | T-NUT BLK
(x2) | 5/16



H100407 | BOLT WH BLK
(x2) | 5/16x1 1/2



H100198 | WASHER LOCK
(x4) | EXT 8x19 BLK



NOTE:

MOUNT ROCK WALL ASSEMBLY USING THE T-NUTS THAT YOU PREVIOUSLY INSTALLED DURING THE ROCK WALL ASSEMBLY STEPS.

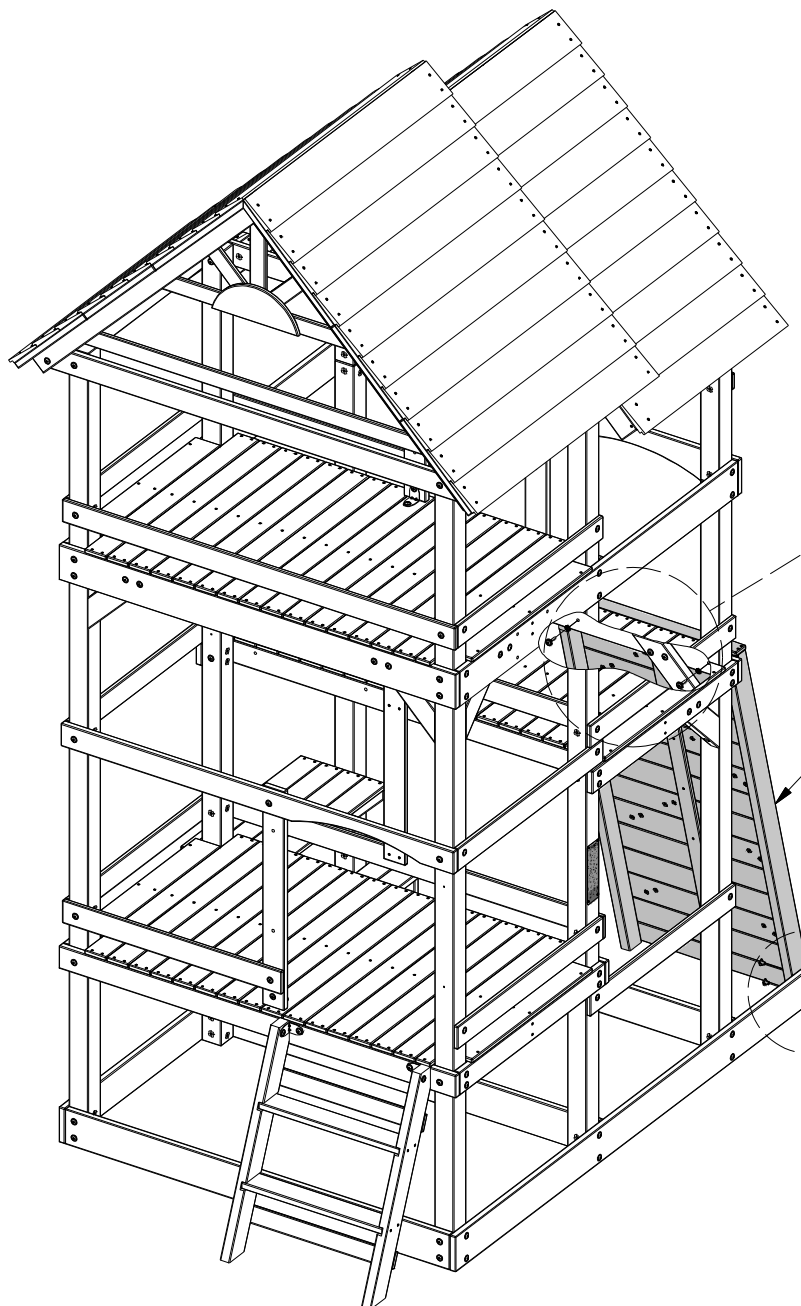

 NOTE PILOT HOLES.

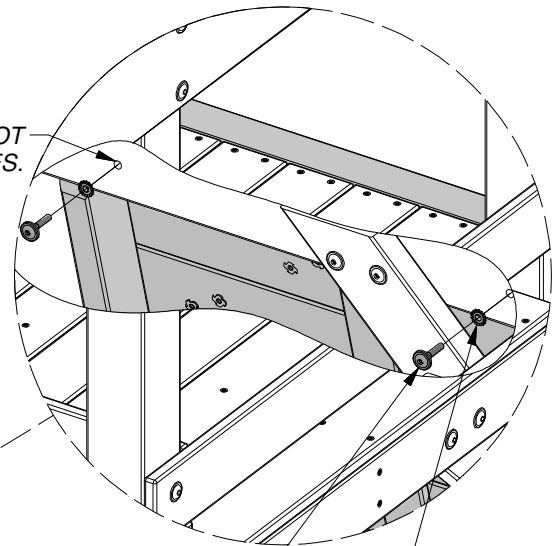

407 (x2)
BOLT - 1-1/2"
198 (x2)
WASHER - 8x19

ROCK WALL (x1)
FROM PREVIOUS STEPS

379 (x2)
T-NUT - 5/16"

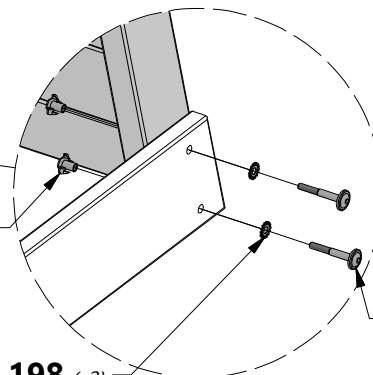

198 (x2)
WASHER - 8x19

205 (x2)
BOLT - 2-1/4"

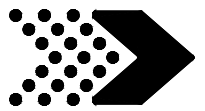

M06 | WALL BOARD - W4L13952
(x8) 5/8"x3 3/8"x23 1/4" (16x86x591)

M07 | WALL BOARD - W4L13951
(x8) 5/8"x3 3/8"x26 5/8" (16x86x677)

H100088 | SCREW PFH
(x64) 8x1 1/8"

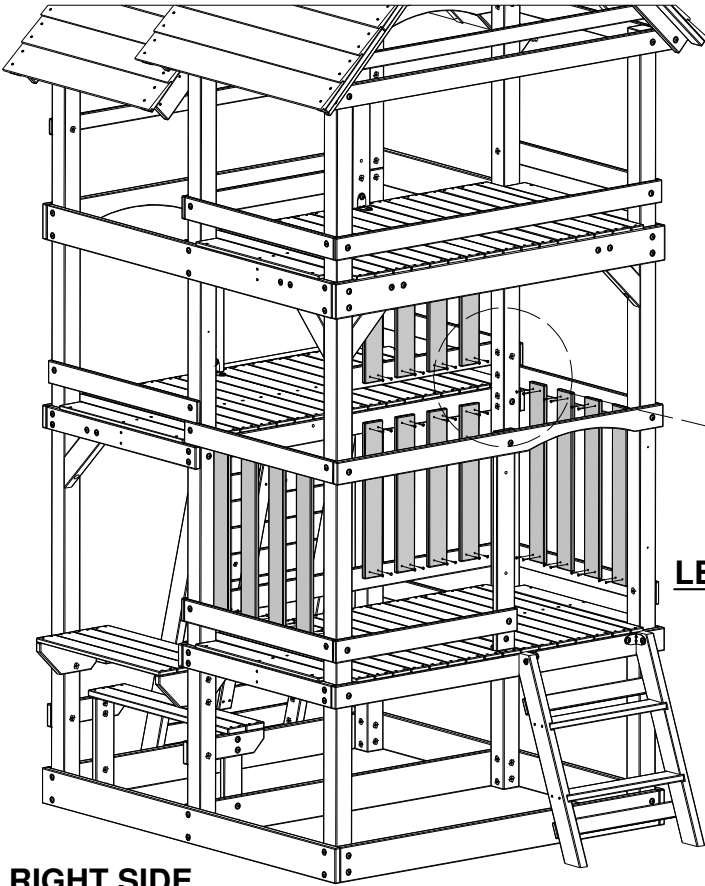

TIP:
USE THE PROVIDED PICKET PAL TO SPACE AND INSTALL EACH PICKET AS SHOWN TO THE DIMENSIONS PROVIDED BELOW.

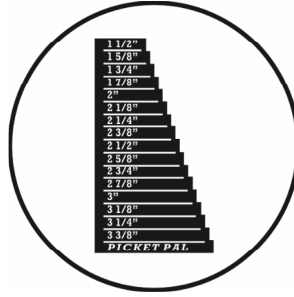

LEFT SIDE

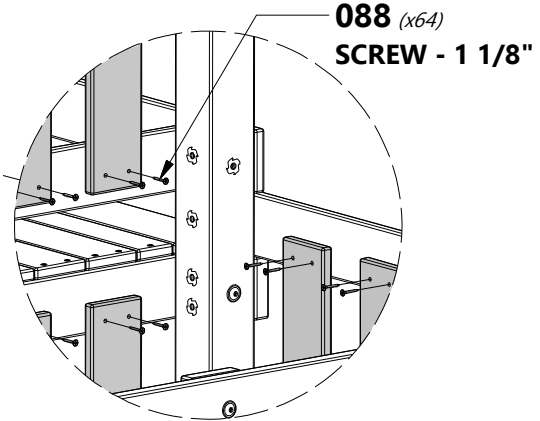

088 (x64)
SCREW - 1 1/8"

RIGHT SIDE

BACK SIDE

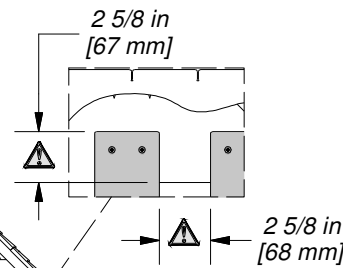

1 3/4 in [43 mm]

M07 (x4)
WALL BOARD

3 in [76 mm]

RIGHT SIDE PICKETS

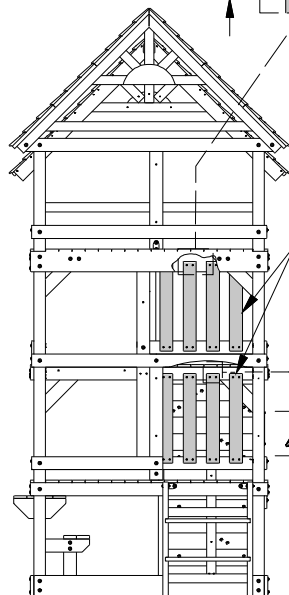

M06 (x8)
WALL BOARD

2 3/8 in [59 mm]

CENTER PICKETS

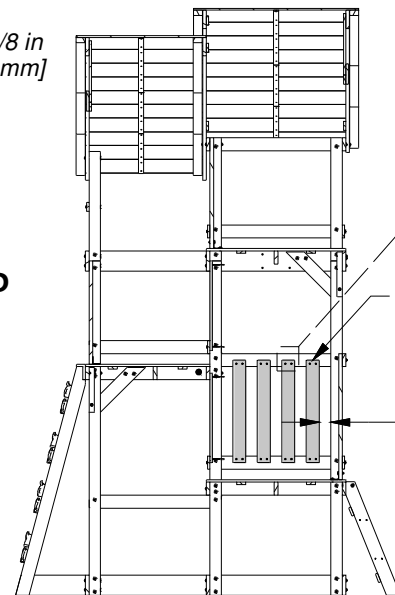

1 3/4 in [43 mm]

M07 (x4)
WALL BOARD

3 in [76 mm]

LEFT SIDE PICKETS



M06 | WALL BOARD - W4L13952
(x4) 5/8"x3 3/8"x23 1/4" (16x86x591)

M07 | WALL BOARD - W4L13951
(x4) 5/8"x3 3/8"x26 5/8" (16x86x677)

H100088 | SCREW PFH
(x32) 8x1 1/8"

CENTER PICKETS

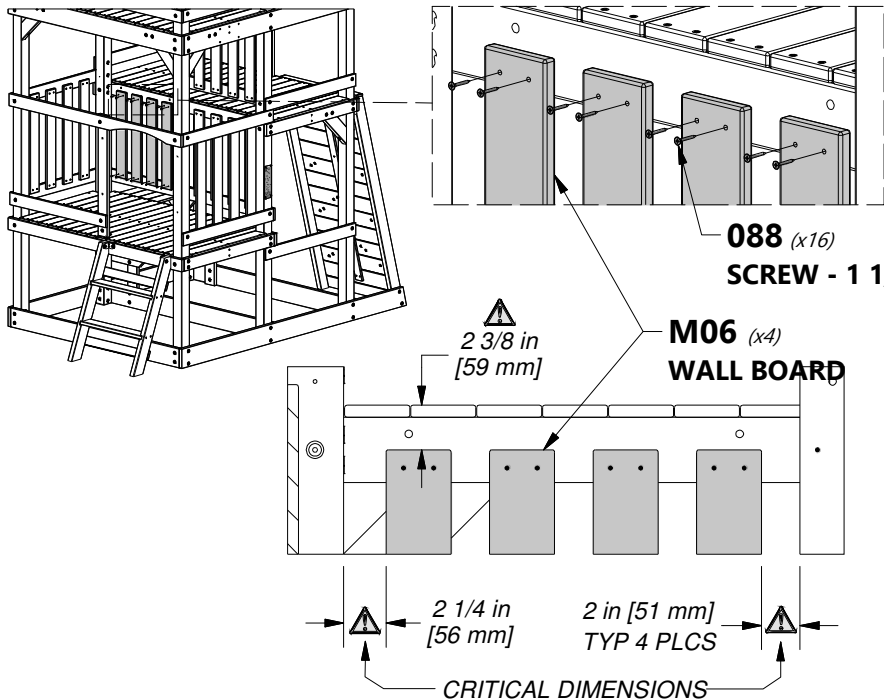

TIP:

USE THE PROVIDED PICKET PAL TO SPACE AND INSTALL EACH PICKET AS SHOWN TO THE DIMENSIONS PROVIDED BELOW.

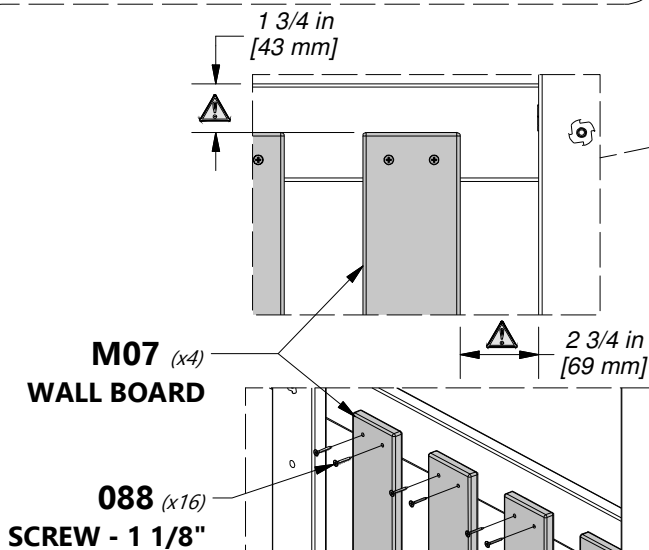
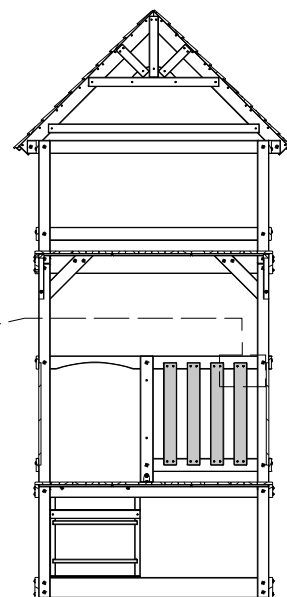
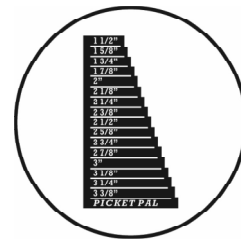

FRONT PICKETS

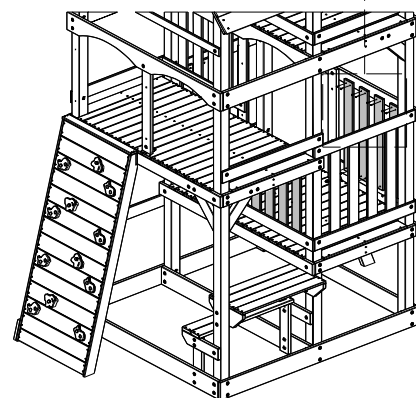

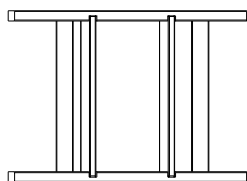

LADDER ASSEMBLY
FROM PREVIOUS STEPS



H100468 BOLT WH BLK
(x2) | 5/16x1



NOTE:

T-NUTS WERE INSTALLED IN PREVIOUS STEPS AND AREN'T SHOWN IN THIS VIEW.

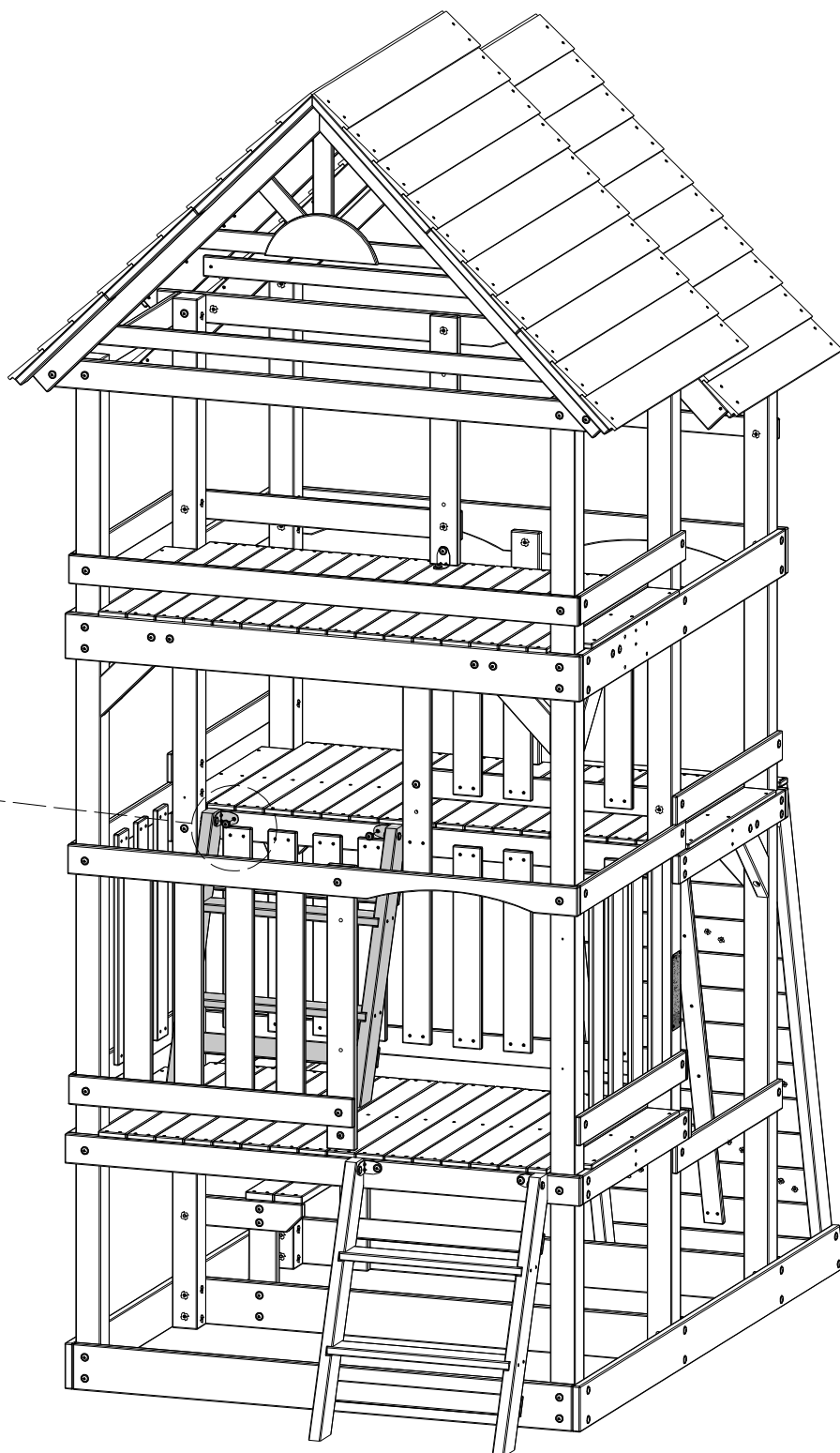

468 (x2)
BOLT - 1"

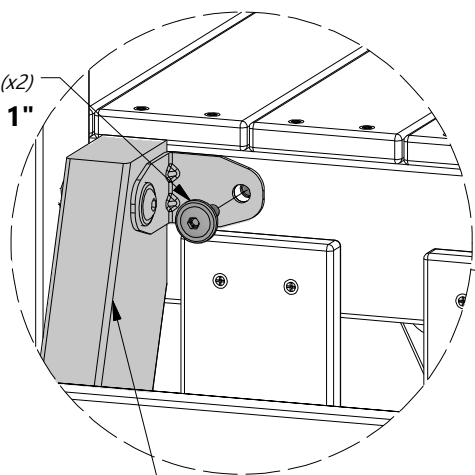

LADDER ASSEMBLY



M06 | WALL BOARD - W4L13952
(x8) | 5/8"x3 3/8"x23 1/4" (16x86x591)

H100088 | SCREW PFH
(x32) | 8x1 1/8

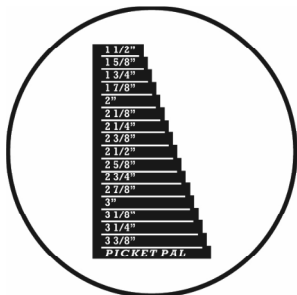

TIP:

USE THE PROVIDED PICKET PAL TO SPACE AND INSTALL EACH PICKET AS SHOWN TO THE DIMENSION PROVIDED BELOW.

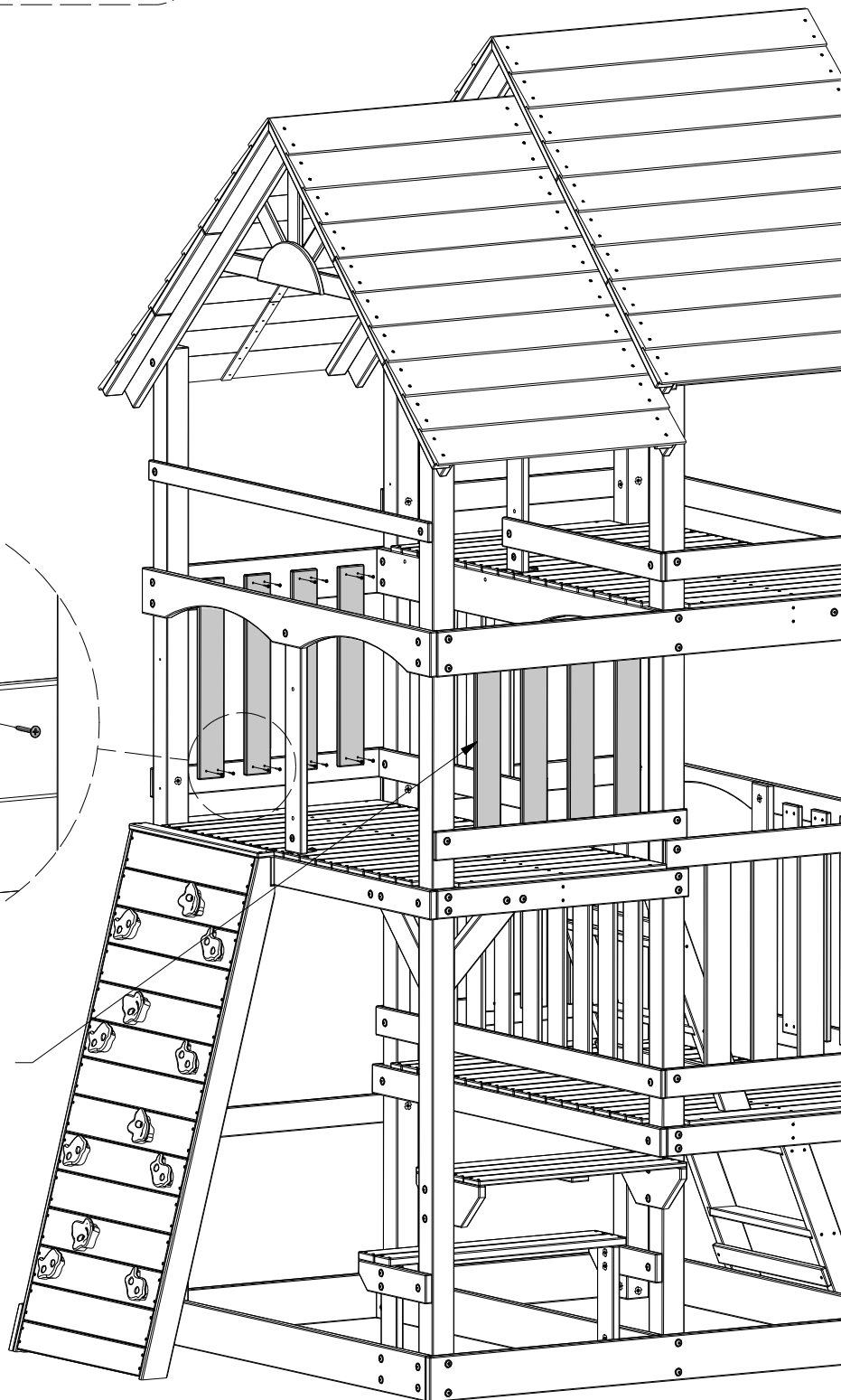

M06 (x4)
WALL BOARD

1 3/4 in
[43 mm]

3 in
[76 mm]

088 (x16)
SCREW - 1 1/8"

REPEAT ON OPPOSITE SIDE

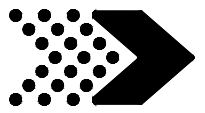

O2 | WALL BOARD - W4L13921
 (x14) | 5/8"x1 3/8"x14" (16x36x356)

H100088 | SCREW PFH
 (x28) | 8x1 1/8"

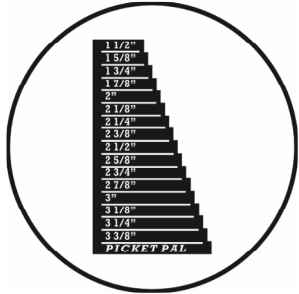

TIP:
 USE THE PROVIDED PICKET PAL TO SPACE AND INSTALL EACH PICKET AS SHOWN TO THE DIMENSION PROVIDED BELOW.

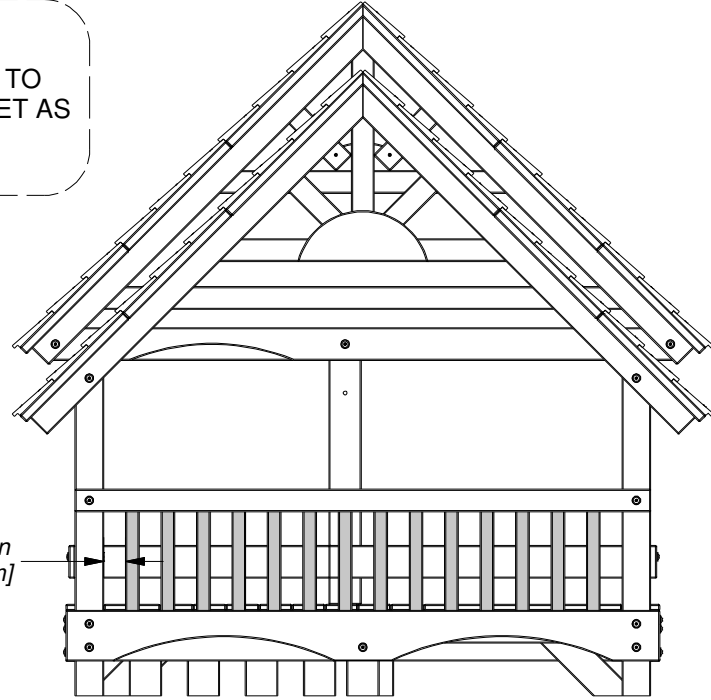

FRONT VIEW

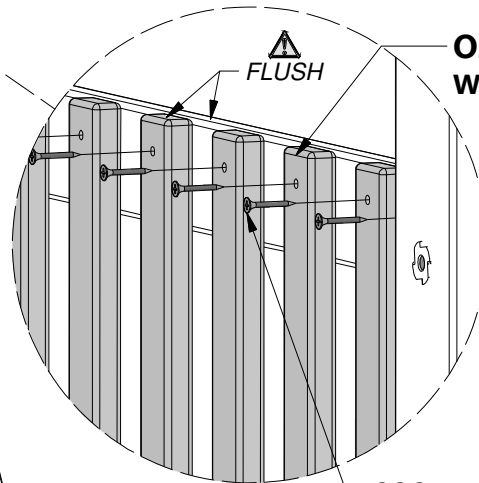
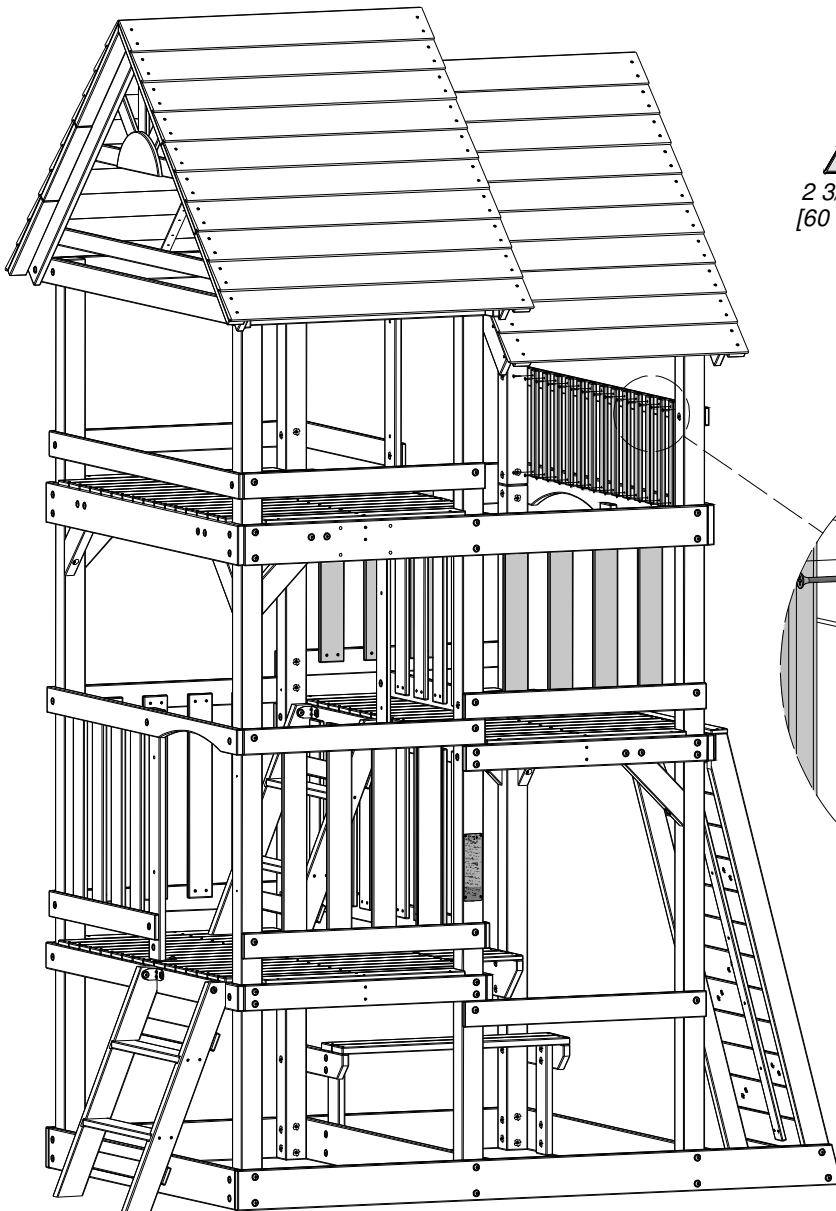

O2 (x14)
WALL BOARD

088 (x28)
SCREW - 1 1/8"

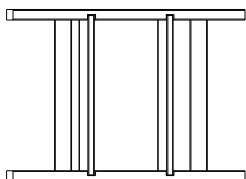

LADDER ASSEMBLY
FROM PREVIOUS STEPS



H100468 | BOLT WH BLK
(x2) | 5/16x1



NOTE:

T-NUTS WERE INSTALLED IN PREVIOUS STEPS AND AREN'T SHOWN IN THIS VIEW.

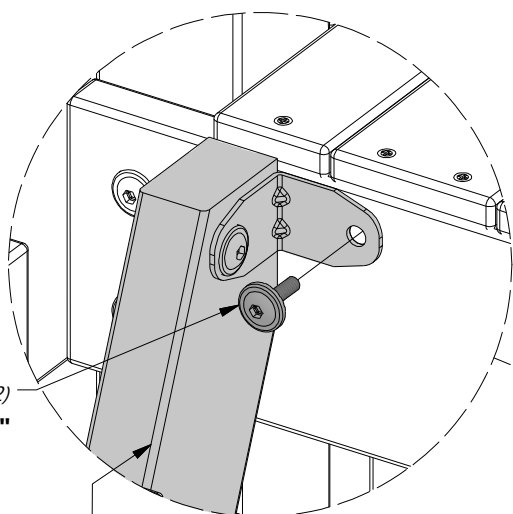

468 (x2)
BOLT - 1"

LADDER ASSEMBLY

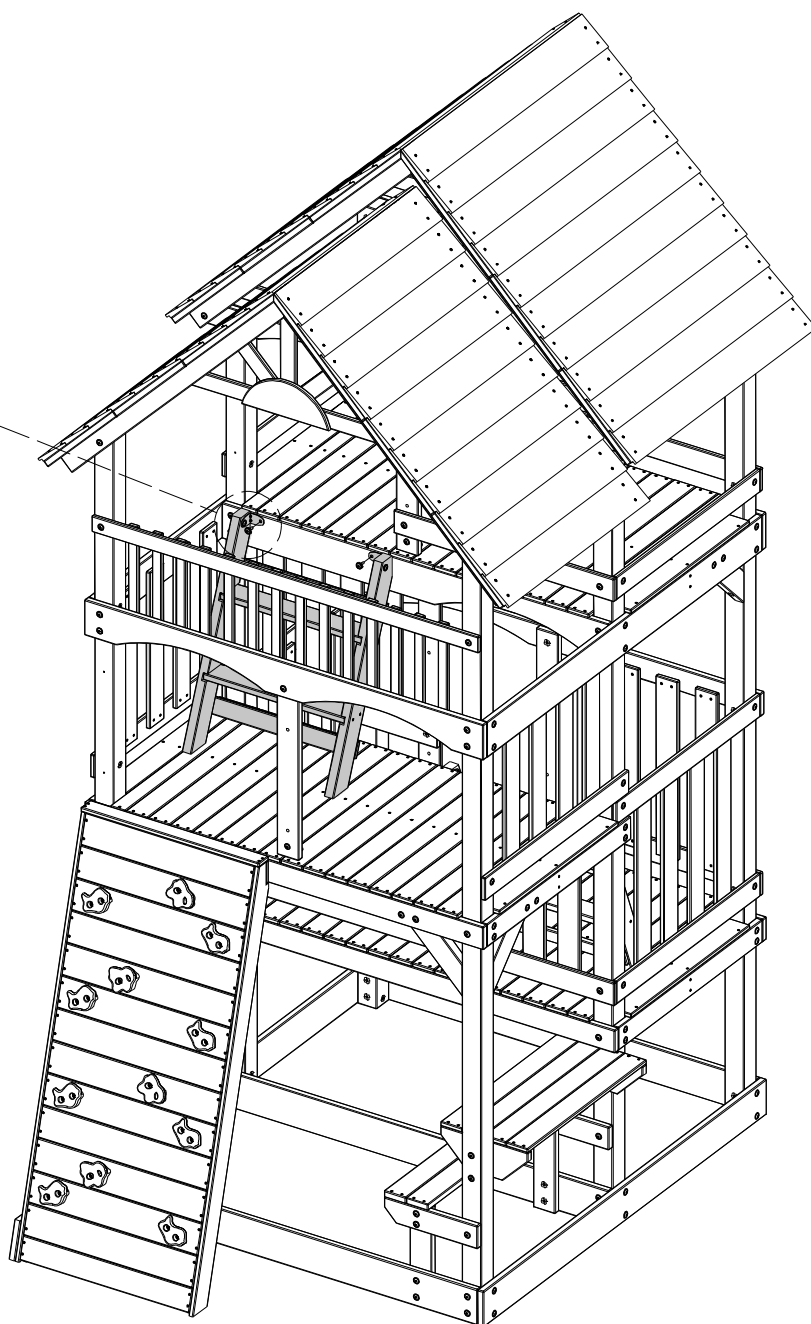

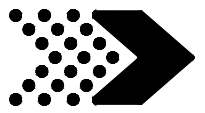

M06 | WALL BOARD - W4L13952
 (x8) | 5/8"x3 3/8"x23 1/4" (16x86x591)

H100088 | SCREW PFH
 (x32) | 8x1 1/8"

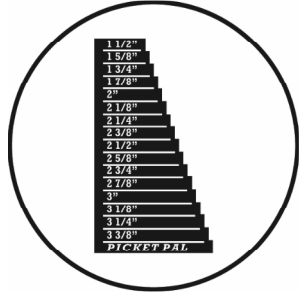

TIP:
 USE THE PROVIDED PICKET PAL TO SPACE AND INSTALL EACH PICKET AS SHOWN TO THE DIMENSIONS PROVIDED BELOW.

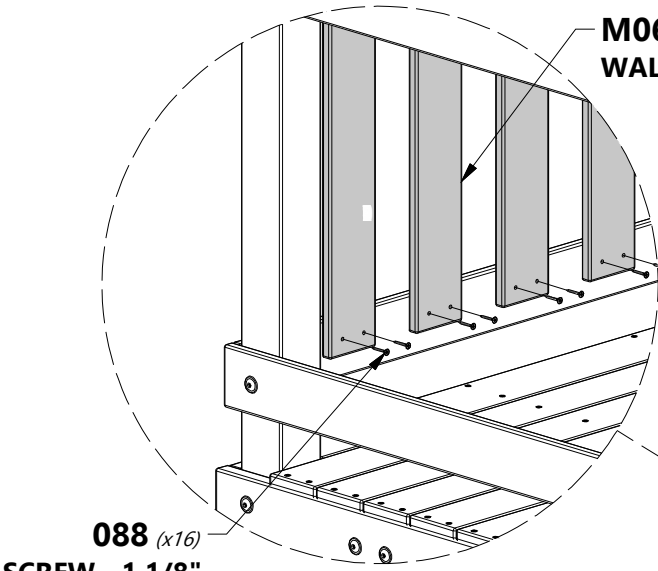

REPEAT ON OPPOSITE SIDE

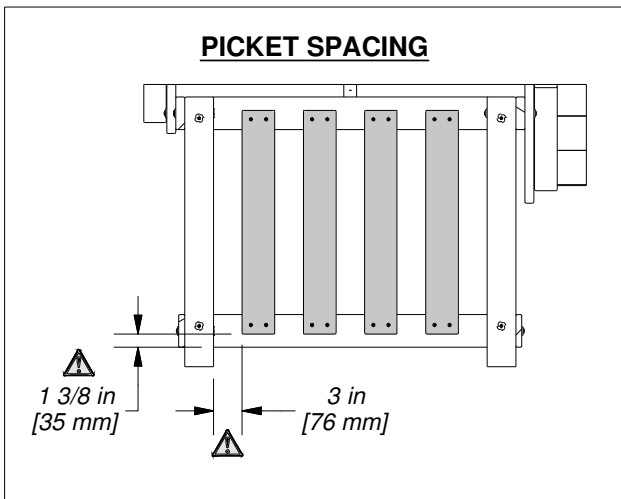
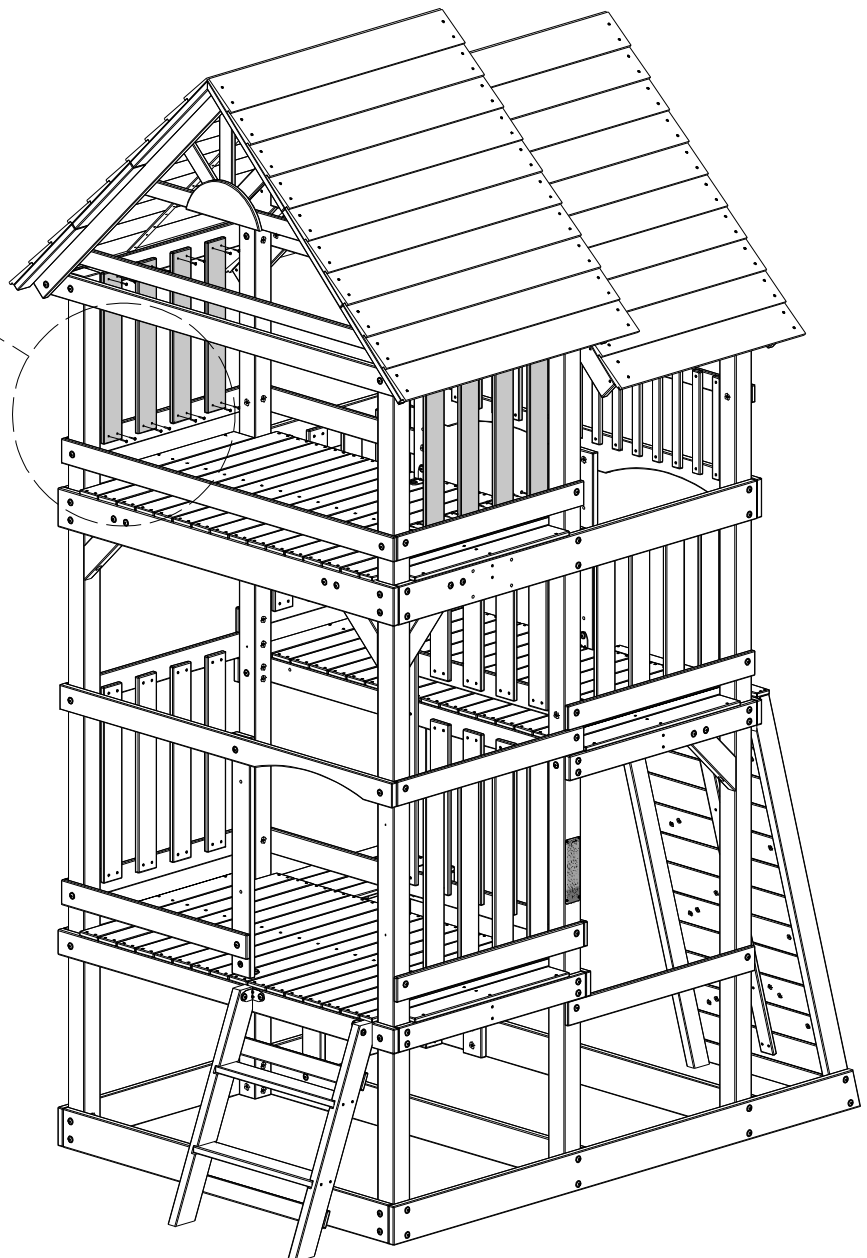

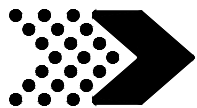

M06 | WALL BOARD - W4L13952
(x12) | 5/8"x3 3/8"x23 1/4" (16x86x591)

H100088 | SCREW PFH
(x48) | 8x1 1/8"

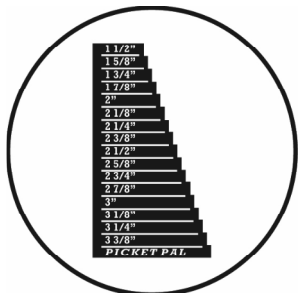

TIP:
USE THE PROVIDED PICKET PAL TO SPACE AND INSTALL EACH PICKET AS SHOWN TO THE DIMENSIONS PROVIDED BELOW.

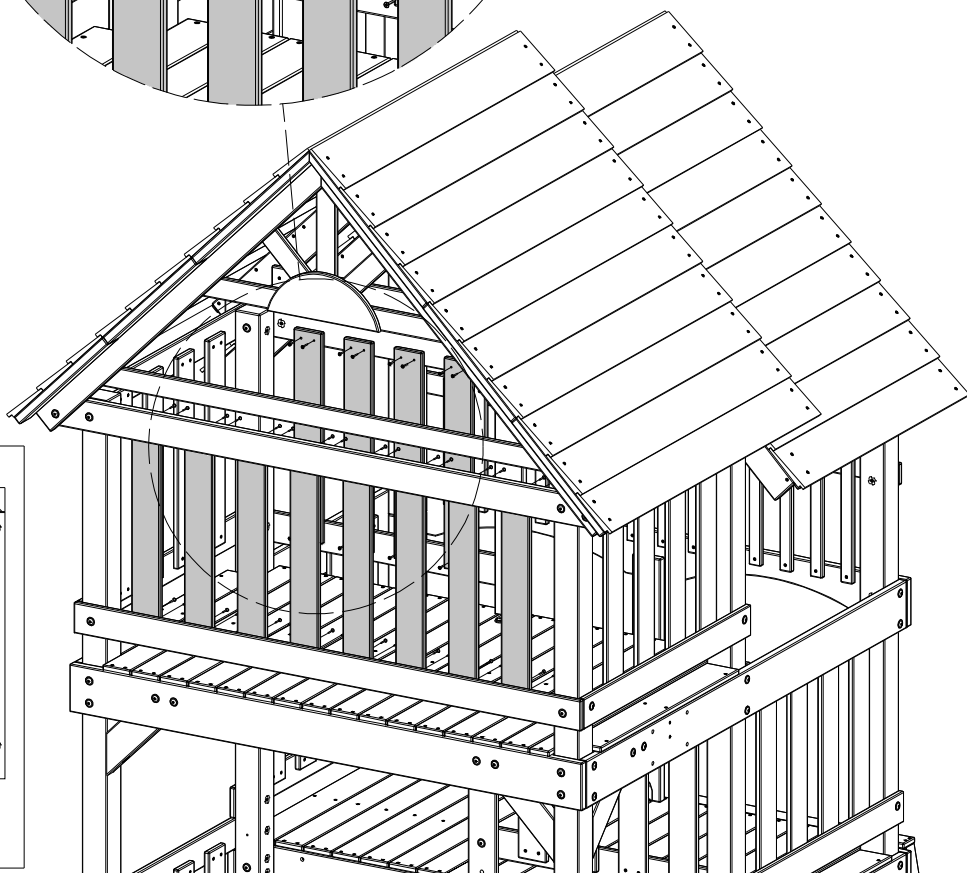
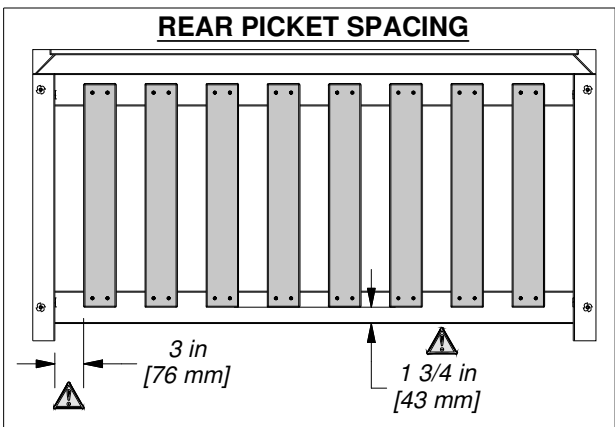
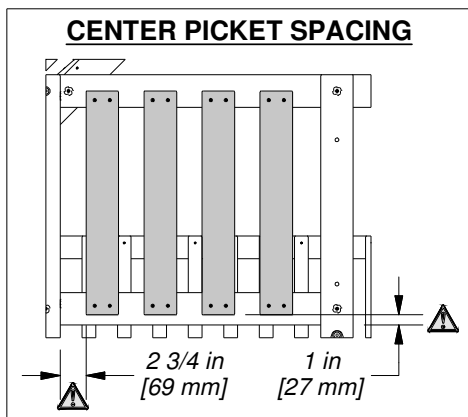
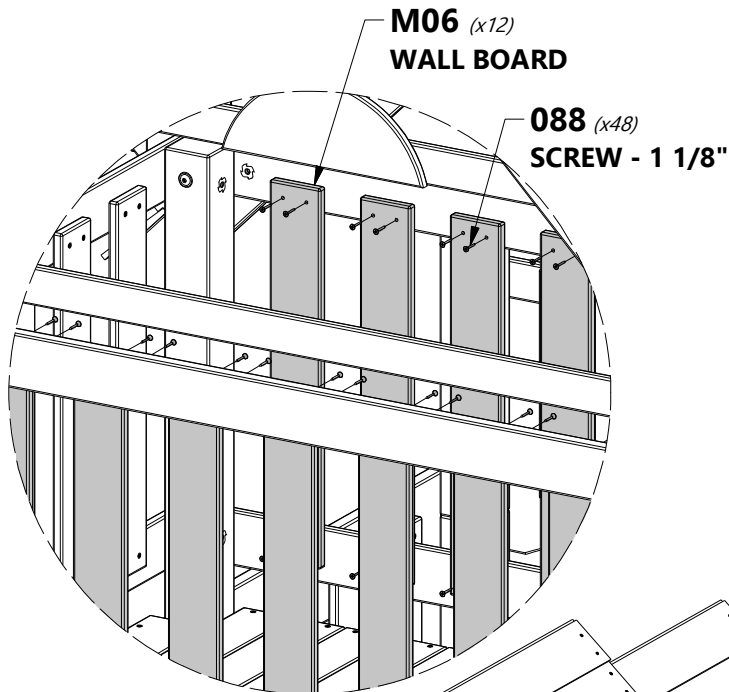

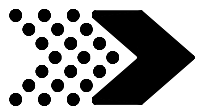

FORT ASSEMBLY

STEP 37



A100118 | **HAND GRIP**
(x8) | **METAL GREEN**
381 c/c



H100468 | **BOLT WH BLK**
(x6) | 5/16x1



H100458 | **LAG SCREW WH BLK**
(x8) | 5/16x2



H100663 | **BOLT WH BLK**
(x2) | 5/16x3/4



H100379 | **T-NUT BLK**
(x8) | 5/16

⚠ LOOSEN RAFTER BOLT TO HELP WITH GRAB HANDLE INSTALL.

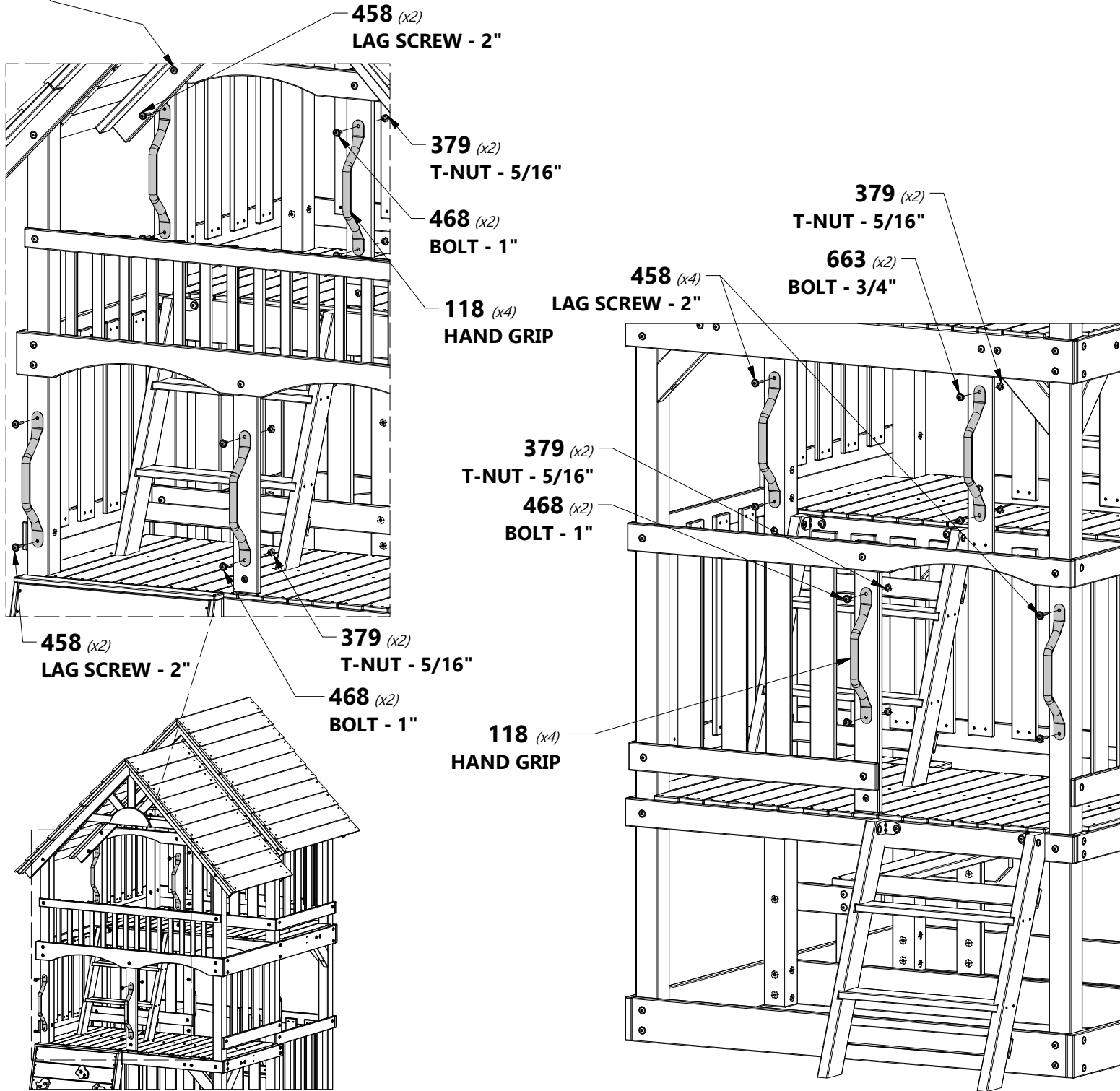

FRONT VIEW

REAR VIEW



SWING BEAM ASSEMBLY
FROM PREVIOUS STEPS

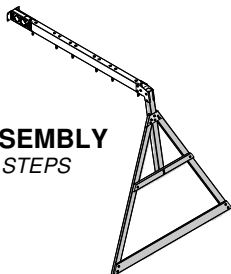

H100481 | BOLT HEX BLK
(x4) | 5/16x1 1/4



H100477 | WASHER SPLIT BLK
(x4) | 5/16



H100478 | WASHER FLAT BLK
(x4) | 8x27



NOTE:
INSTALL SWING BEAM USING
T-NUTS PREVIOUS INSTALLED.

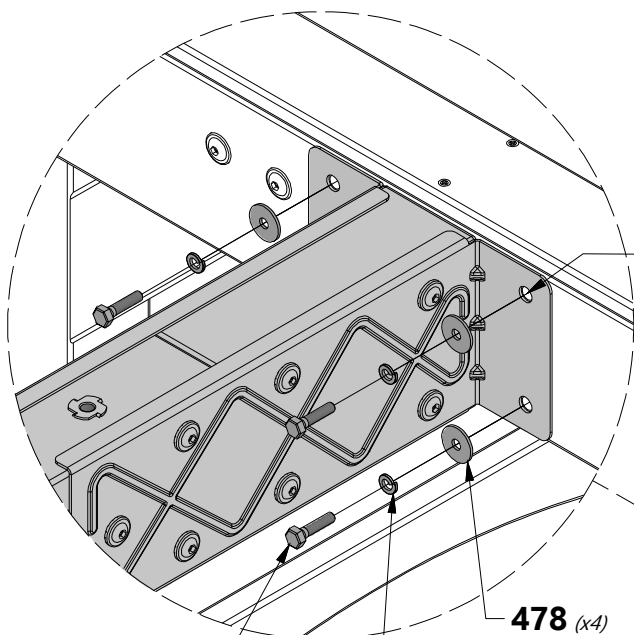

NOTE PILOT HOLES.

481 (x4)
BOLT - 1 1/4"

477 (x4)
WASHER - 5/16

478 (x4)
WASHER - 8x27

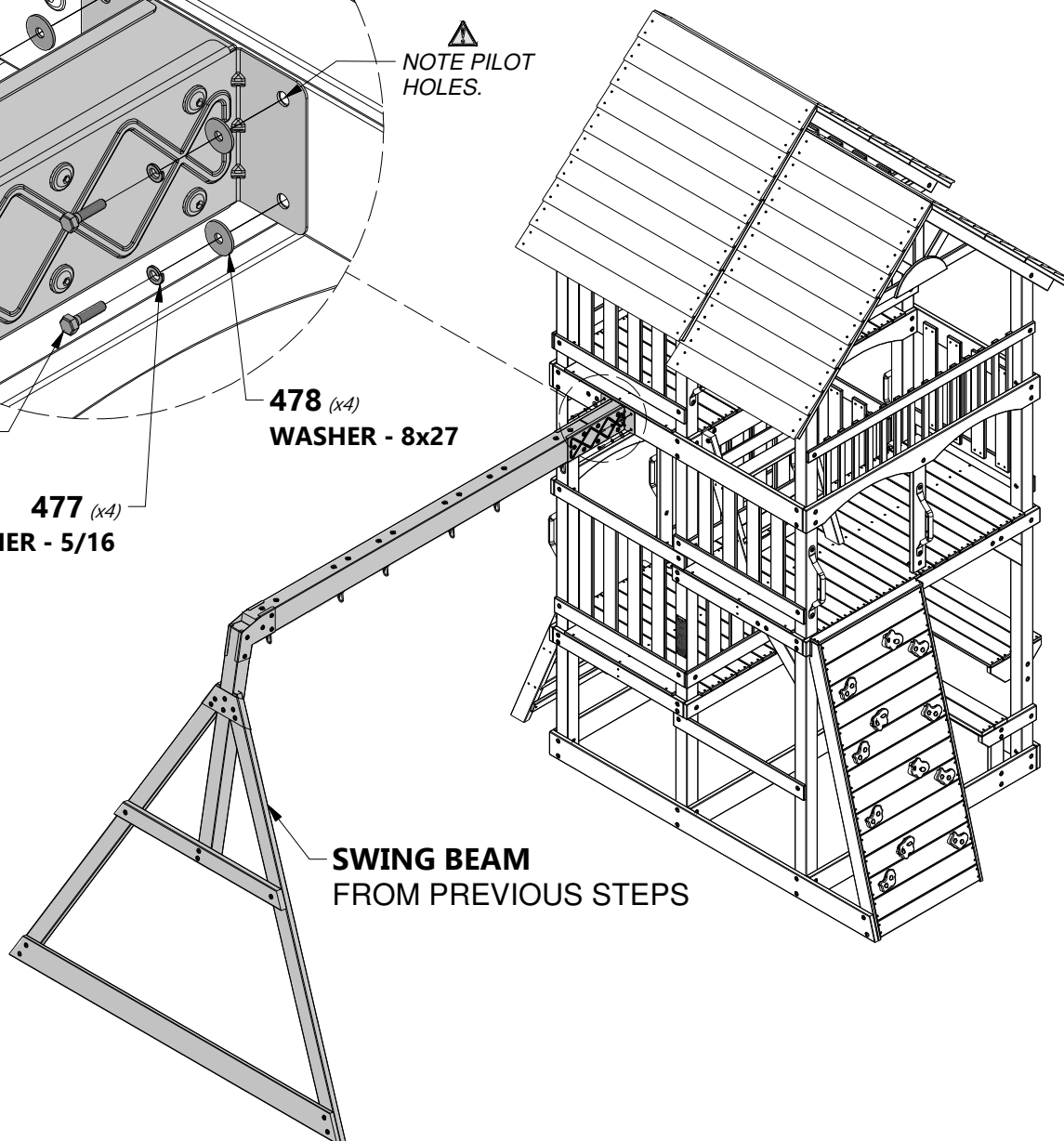

SWING BEAM
FROM PREVIOUS STEPS



FORT ASSEMBLY

STEP 39



A100069 (x4) QUICK LINK



A100164 (x1) BYD ID TAG (LARGE) AGES 3-10



A100047 (x4) CHAIN GREEN 57"



A6P00054 (x2) SWING SEAT GREEN 22"

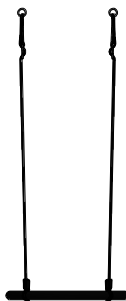

A4M01126 (x1) 26" WEB SWING SEAT ROPE



H100202 (x4) SCREW PWH BLK 8x5/8

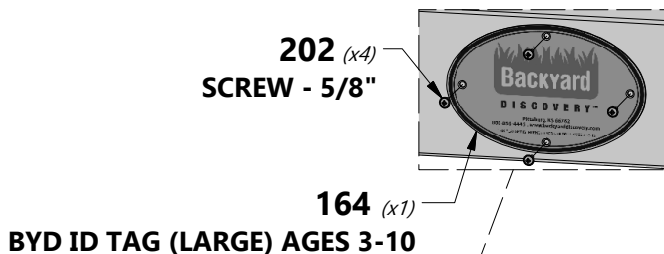
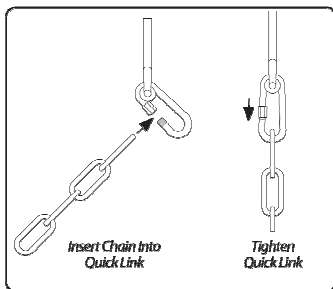

202 (x4) SCREW - 5/8"

164 (x1) BYD ID TAG (LARGE) AGES 3-10

126 (x1) 26" WEB SWING

047 (x4) CHAIN GREEN 57"

069 (x4) QUICK LINK

054 (x2) SWING SEAT GREEN 22"

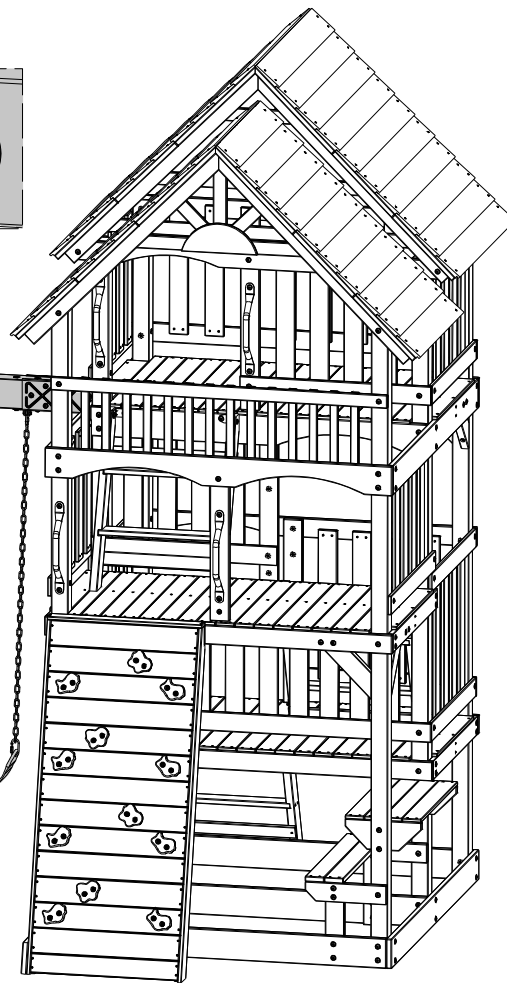
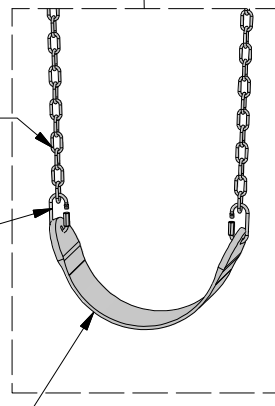



FORT ASSEMBLY

STEP 40



A100178 | AUGER GROUND STAKE
(x6)



H100468 | BOLT WH BLK
(x6) | 5/16x1



H100199 | WASHER LOCK EXT BLK
(x6) | 12x19



H100469 | NUT BARREL WH BLK
(x6) | 5/16x5/8



NOTE:

TWIST GROUND STAKE INTO THE GROUND WHERE SHOWN. THEN USING GROUND STAKE AS A GUIDE, DRILL A 7/16" (10mm) HOLE FOR HARDWARE.

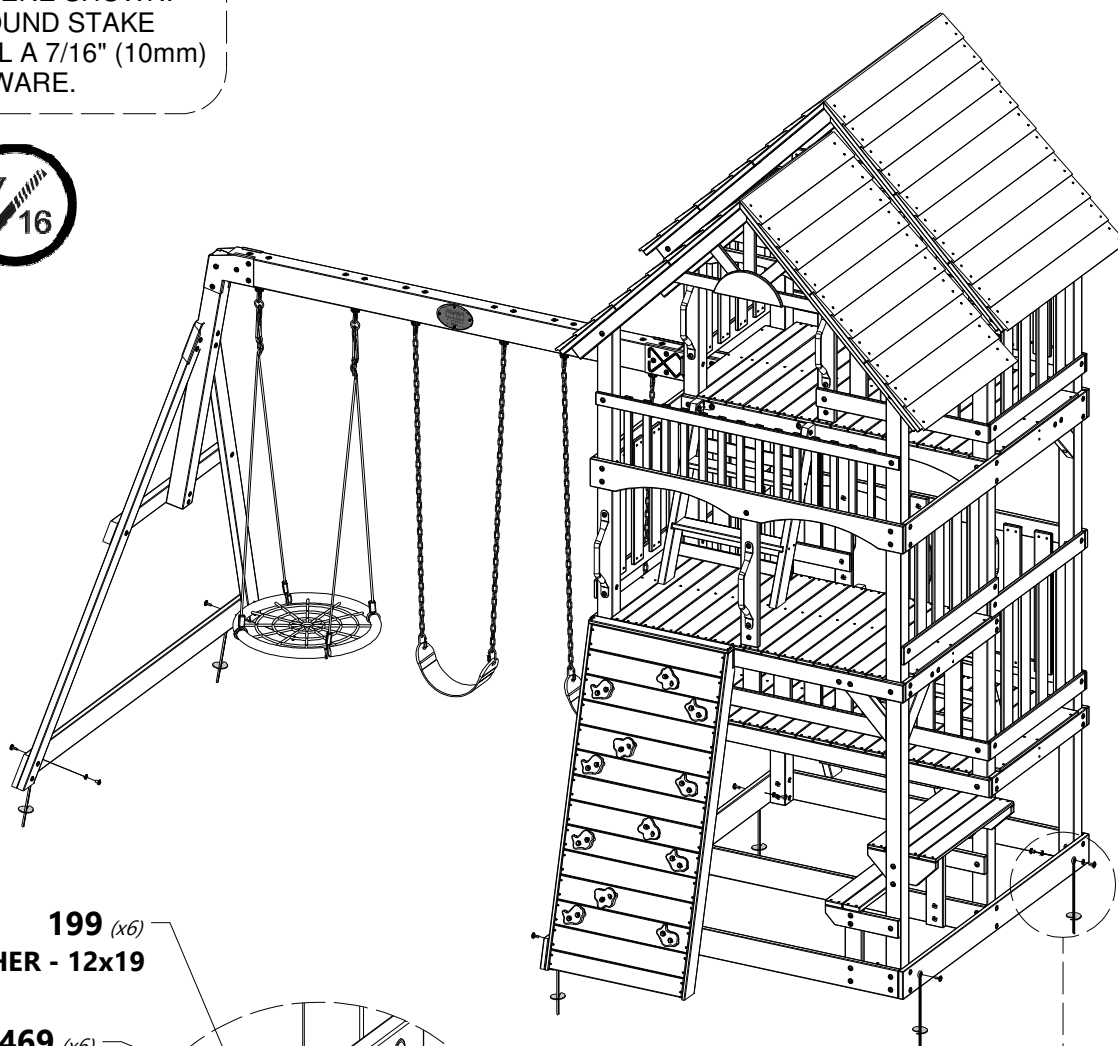
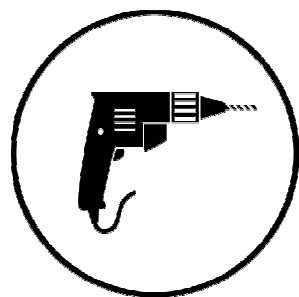

199 (x6)
WASHER - 12x19

469 (x6)
NUT BARREL - 5/8

468 (x6)
BOLT - 1"

178 (x6)
AUGER GROUND STAKE

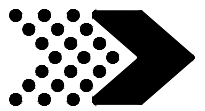

O70 | SLIDE MOUNTING BOARD - W4L09040
 (x1) | 5/8"x1 3/8"x20 3/8" (16x34x517)

H100088 | SCREW PFH
 (x4) | 8x1 1/8"

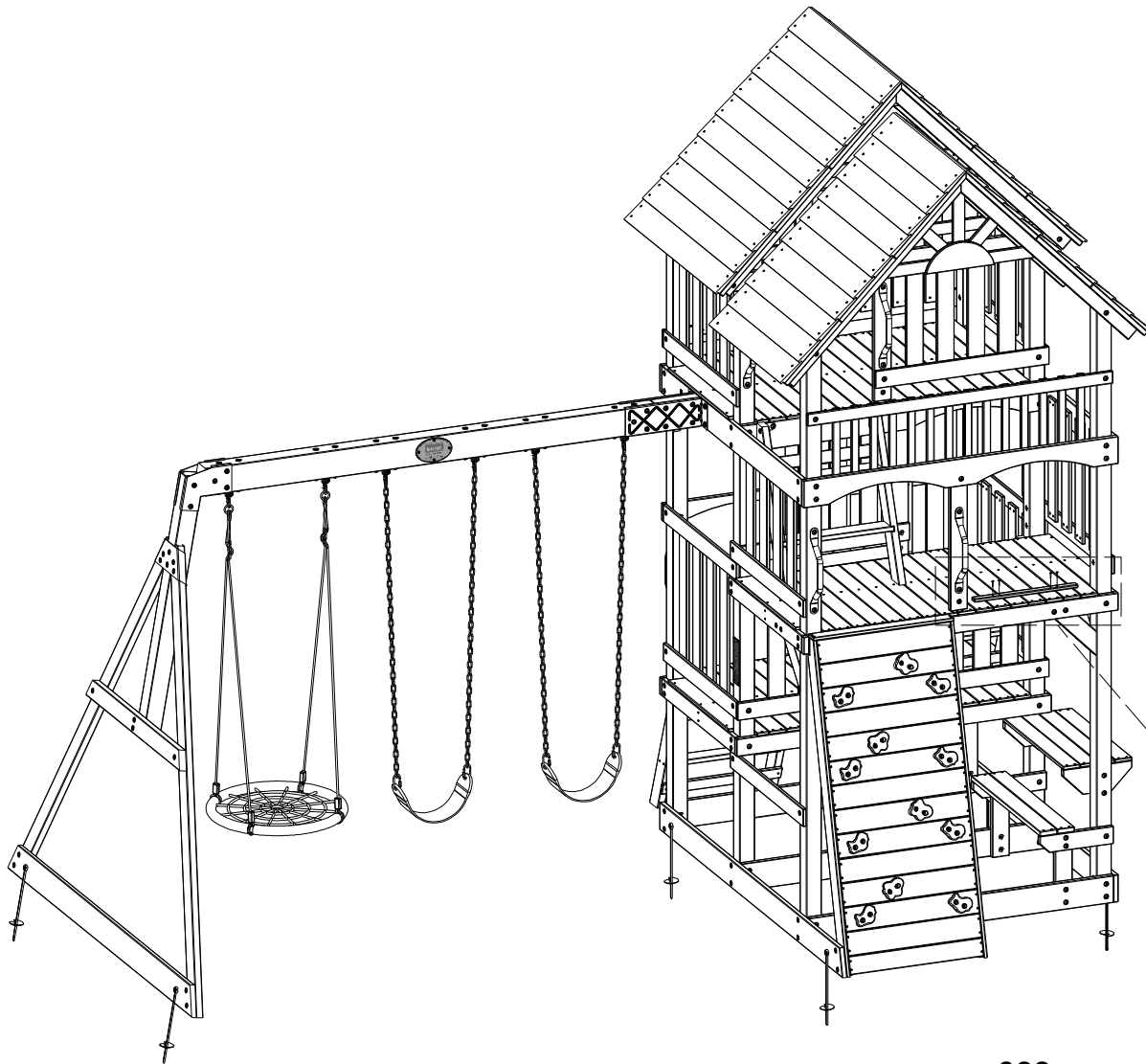

O70 BOARD PLACEMENT

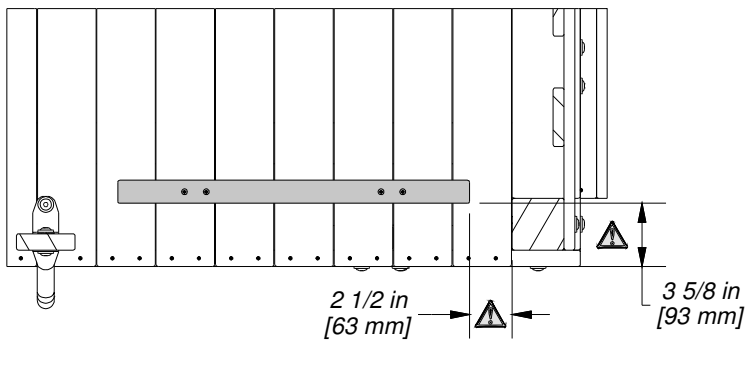

088 (x4)
 SCREW - 1 1/8"

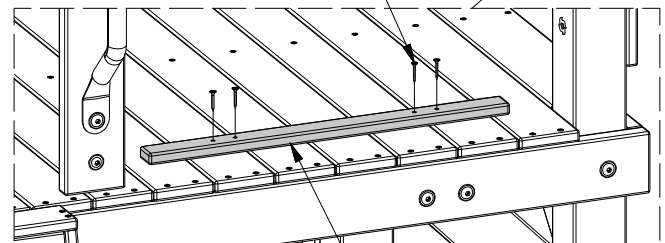

O70 (x1)
 SLIDE MOUNTING BOARD

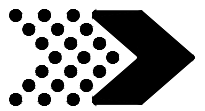

FORT ASSEMBLY

STEP 42

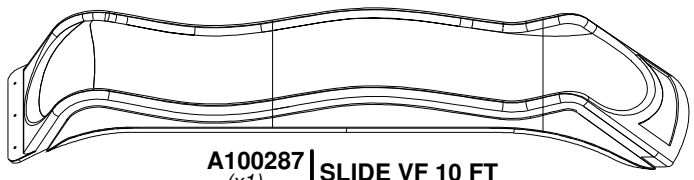

A100287 | SLIDE VF 10 FT
(x1)



H100459 | BOLT WH BLK
(x3) | 5/16x1 1/4



H100379 | T-NUT BLK
(x3) | 5/16



NOTE:

PLACE THE SLIDE USING THE DIMENSIONS SHOWN BELOW. ONCE IN PLACE USE THE SLIDE AS A TEMPLATE AND DRILL (3) 3/8" (10 mm) HOLES. USE THE HOLES TO MOUNT THE SLIDE WITH THE INCLUDED HARDWARE.

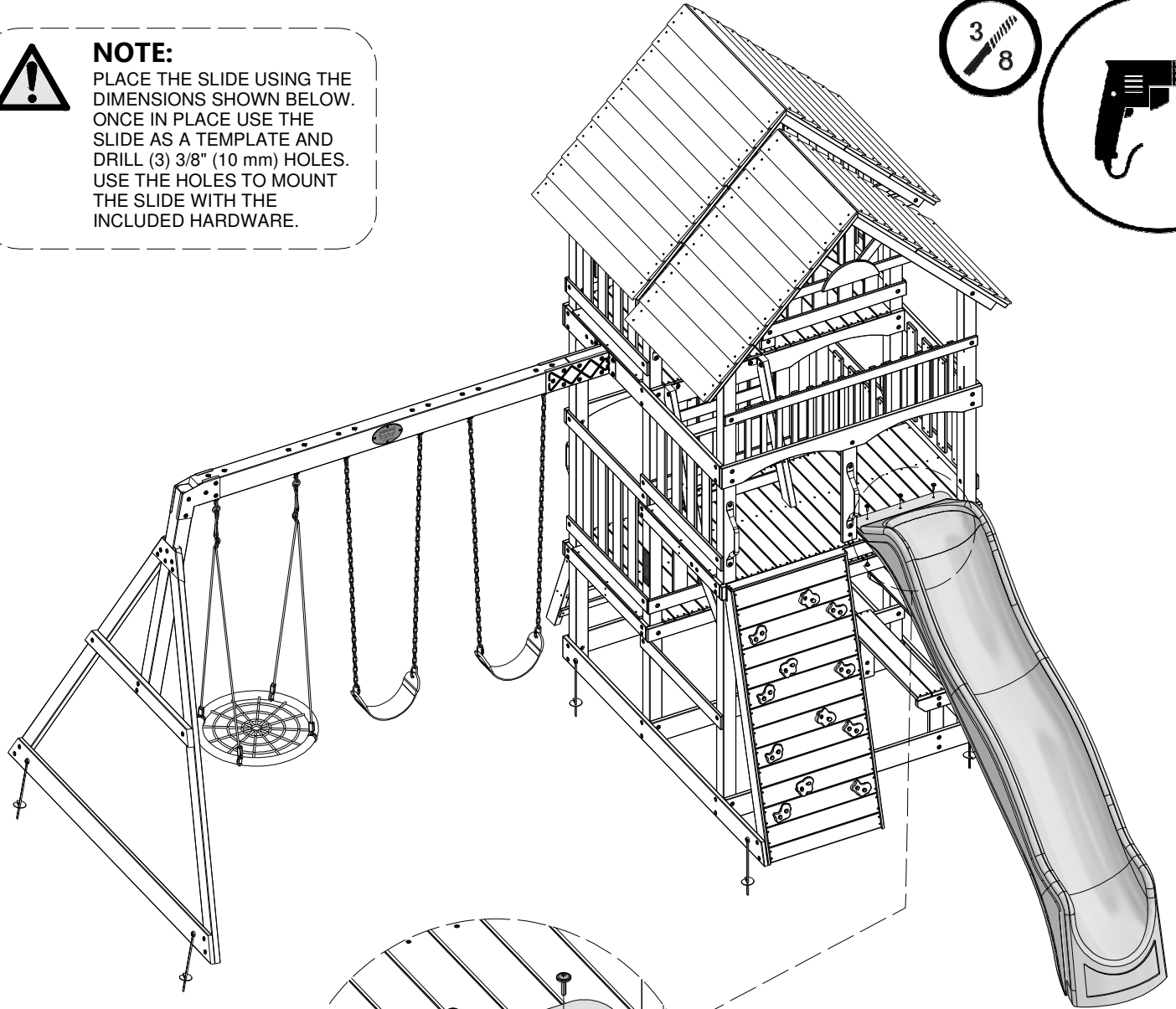
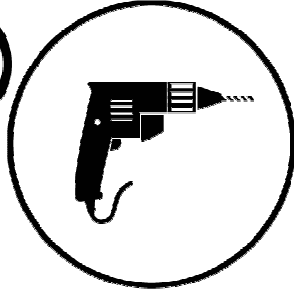

- 459 (x3)**
BOLT - 1-1/4"
- 287 (x1)**
SLIDE VF 10 FT
- 379 (x3)**
T-NUT - 5/16"

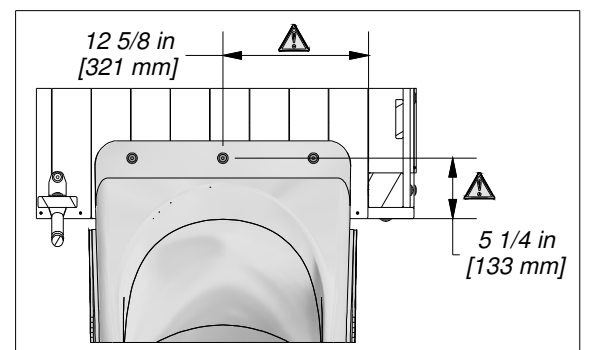
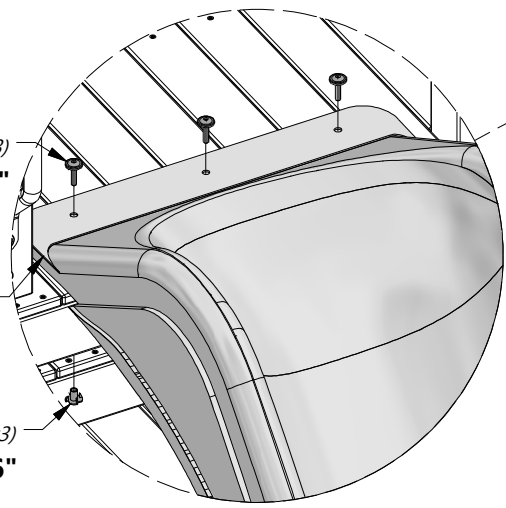

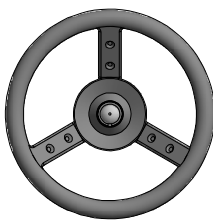

A100107 (x1) STEERING WHEEL

TIP: FOR EASIER ASSEMBLY AND TO KEEP BOARD FROM SPLITTING PRE-DRILL PICKET USING A 3/16" (5 mm) DRILL BIT.

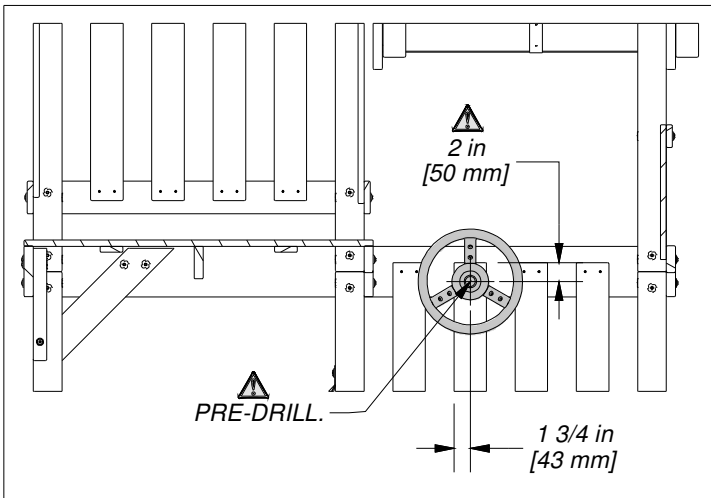
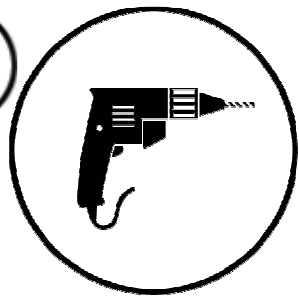

107 (x1) STEERING WHEEL

WASHER FLAT 8x27 (x1) (INCLUDED WITH STEERING WHEEL)

LAG SCREW HEX 5/16x2 (x1) (INCLUDED WITH STEERING WHEEL)

CENTER CAP (x1) (INCLUDED WITH STEERING WHEEL)

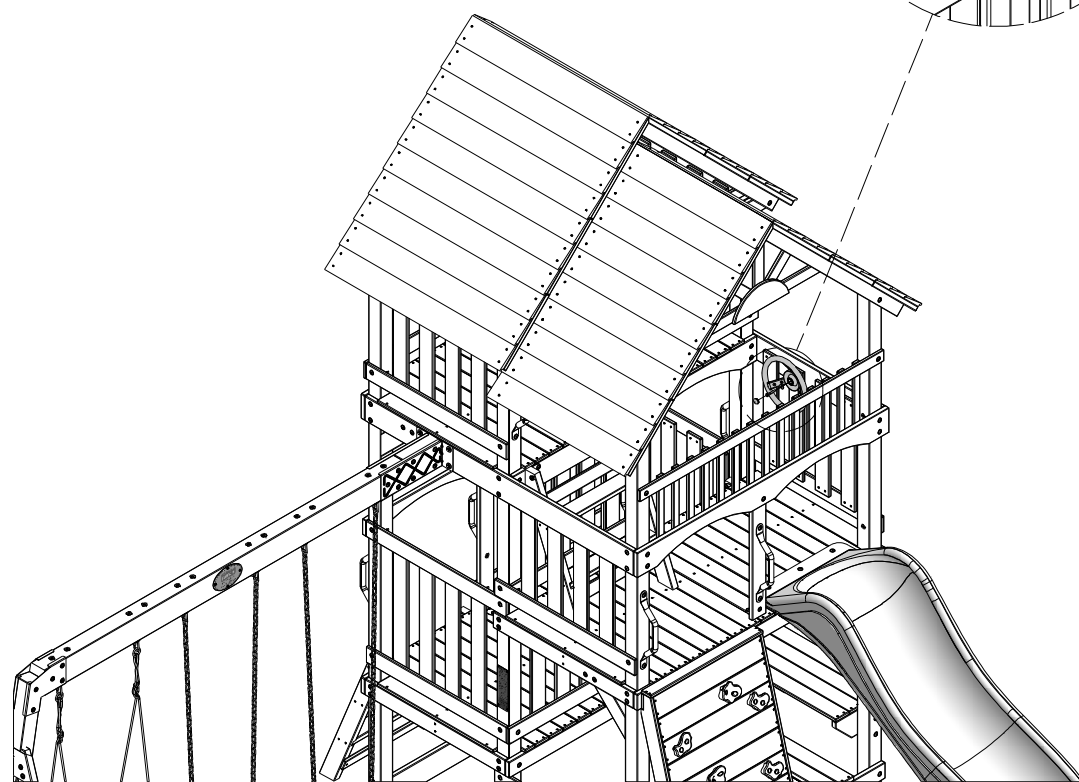
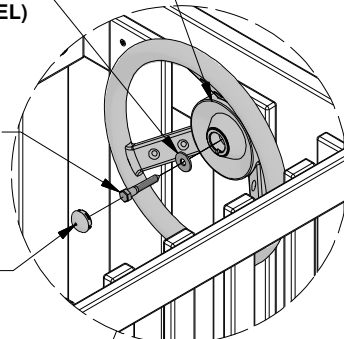



INCLUDED IN TELESCOPE KIT

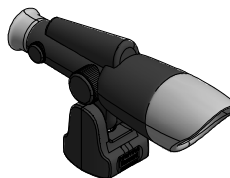

A100104 (x1) TELESCOPE KIT



H100082 (x1) SCREW TAPPING
14x2 1/2



H100225 (x1) FLANGE CUP WASHER
9x34



H100483 (x2) SCREW PFH BLK
8x2 1/4

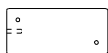

F01 (x1) TELESCOPE MOUNT - W4L13974
1 3/8"x2 3/8"x5 1/4" (36x60x134)

