

T =	.932±	.008
E =	.848±	.008
H =	.646±	.015
I =	.516 MIN	
S =	.046±	.015

DETAIL A

Overflow Capacity: 261 ml ± 7

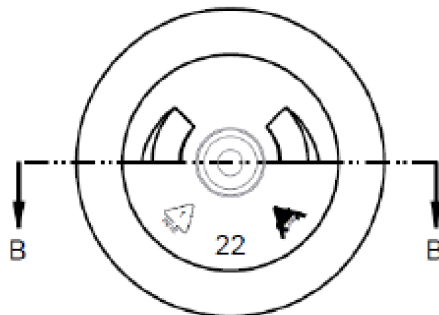
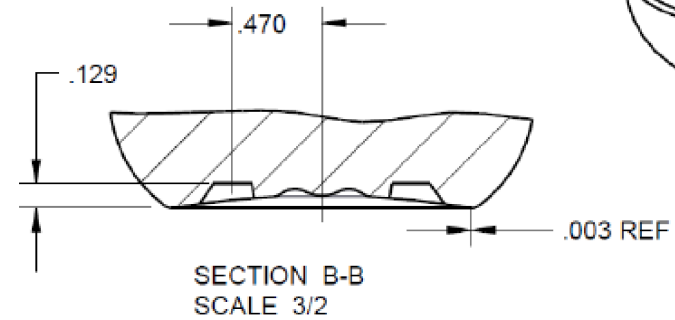
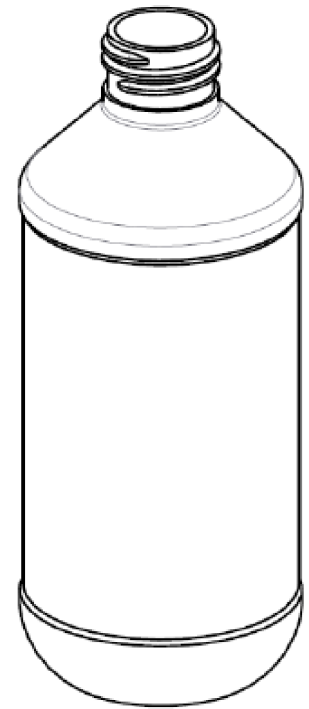

DISCLAIMER

THIS INFORMATION IS PROVIDED AS A GENERAL GUIDE, INCLUDING DIMENSIONS. IT IS THE CUSTOMER'S RESPONSIBILITIES TO SELECT THE PROPER CONTAINER FOR PRODUCT AND APPLICATION COMPATIBILITY.

DISTRIBUTED BY:



REF NO.:

DWG10075

DESCRIPTION:

8 oz PET Modern Round, 24-410