

Model ZW209 & ZW209BP LEAD-FREE*

Pressure Reducing Valve Assembly & with Low Flow By-Pass
Globe and Angle Pattern Bodies

1 1/4", 1 1/2", 2", 2-1/2", 3", 4", 6", 8", 10", 12", 14" & 16"

*Contains a weighted average lead content less than 0.25% for wetted surfaces



□ Installation □ Troubleshooting □ Maintenance Instructions

Installation / Start-up

NOTE: Flushing of all pipe lines is to be performed to remove all debris prior to installing valve.

CAUTION: The recommended installation orientation for ACVs is horizontal, with the valve cover up. 6" and larger valves should only be installed horizontally, with the valve cover up, due to the difficulty of properly bleeding air out of the cover on valves installed in the vertical orientation. In addition, the horizontal positioning of the larger valves avoids premature wear due to the mass of plunger assemblies as well as allows for greater accessibility during annual inspections, and maintenance.

NOTE: If installation is subject to very low flow or potentially static conditions it is recommended a pressure relief valve (1/2" minimum) be installed downstream of the pressure reducing valve for additional system protection.

1. For making adjustments and servicing allow for adequate space around the valve before installing valve.
 2. When installing a ZW209 or ZW209BP, gate valves installed on both inlet and outlet are recommended for maintenance allowing for isolation of valve.
 3. Position the valve in line matching the direction of flow as indicated on the valve model tag with the proper direction of flow in the system. Once attached to line, double check all fasteners/bolts in the pilot system and on main valve are tight and there is no damage prior to pressurizing system.
- NOTE: Pressure in some applications can be very high so be thorough in checking and inspecting for proper installation and makeup.**

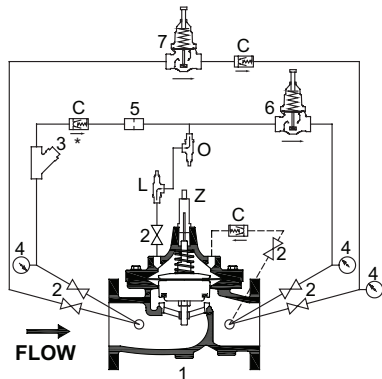

ZW209 SCHEMATIC

STANDARD COMPONENTS

- 1 Main Valve
- 2 850MXL Isolation Valve
- 3 SXL Wye Type Strainer
- 4 Pressure Gauge
- 5 Restriction Tube Fitting
- 6 PRXL PRV (15-150 psi)
- 7 *PRXL Pressure Reducing Control By-Pass (ZW209BP only)

OPTIONAL FEATURES

- C 40XL Hydraulic Check w/ Isolation Valve
- L SC1 Closing Speed Control
- O SC1 Opening Speed Control
- Z ZPI Valve Position Indicator
- 6 PV-PRD (20-200 psi)

START-UP

CAUTION: To prevent personnel injury and damage to equipment check that downstream venting is adequate prior to start-up and test procedures. **All adjustments under pressure should be made slowly while under flowing conditions.** If the main valve closes too fast it may cause surging in upstream piping.

1. Open the pilot ball valves (2) in the pilot system (see ZW209 or ZW209BP schematic).
2. Then slowly open the upstream supply shutoff valve only enough to fill main valve assembly and pilot system. Prior to pressurizing

the valve assembly it is also recommended that a ZPI valve position indicator be installed to aid in verifying proper valve movement.

3. As the valve is filling with water, it is necessary to bleed the main valve and pilot system of air. To vent air, partially open or loosen the highest plugs or fittings in the system. **Use caution when loosening plugs.** The ZPI valve position indicator is a great location, as it has a test cock at the top to vent air pressure. It may be necessary to bleed system more than once. After removal of air in the system tighten all loose fittings. **NOTE: If valve is installed vertically, it will be necessary to loosen some upper cover bolts until you have vented all the air from the cover chamber.**

4. Before setting pilot valve, if valve is equipped with SC1 speed controls (O or L on ZW209 schematic) it is necessary to back out the adjusting screw a minimum of 3 turns from closed position.

5. At this point with the upstream supply shutoff valve partially open, slowly open the downstream system shut off valve. Flow will begin to occur and pressure should build up in valve and eventually stabilize.

6. Next it is advisable to flow water through the valve to ensure all air has been escaped from system. High flow may be needed to flush all air. With water flowing through the valve the Zurn Wilkins Pressure Reducing Valve (PRV) pilot can be set to the desired pressure. To adjust the pilot, loosen jam nut on adjustment screw and either turn adjustment screw in (to increase pressure) or out (to decrease pressure). Tighten jam nut on pilot when the desired setting has been made. Flow at least 5-10 gpm minimum. Higher flow is better for more accurate setting. If valve has a low flow bypass, or a parallel installation, you must close a ball valve in the bypass line and isolate any parallel valves.

7. For ZW209BP the low flow by-pass control must be set 5-10 psi greater than main Pilot PRV. Isolate the main valve by closing the downstream pilot ball valve below the pilot. Open the low flow bypass ball valves. To set the low flow bypass, you only want a trickle of water flowing. Adjust the bypass PRV to 5 psi higher than the main pilot PRV. If you cannot determine the flow, then close the downstream ball valve and then slowly crack the downstream ball valve just until the needle on the pressure gauge drops a small amount (a downstream valve must be partially open to allow for a small amount of flow). Now set the bypass PRV is set slowly open both ball valves on the bypass and open all 3 ball valves in the main pilot PRV piping. Tighten the bypass PRV jam nut. To verify proper operation of ZW209 & ZW209BP slowly close and open downstream system shut off valve several times to ensure downstream pressure is stable at set pressure.

8. After pilot system has been adjusted and the valve is properly regulating the main valve opening and closing speed controls (O or L) can be adjusted as needed. Start with the opening speed control "O" three turns from fully closed. Unscrew stem to speed up the valve opening (will help if downstream pressure drops too far when there is a sudden increase of demand). If wild pressure fluctuations and chatter occur at low flow, turn the setting screw in slowly until valve stabilizes. A closing speed control "L" is not normally used on a pressure reducing valve because a closing speed control can cause downstream high pressure surges. If present, start with this wide open by unscrewing the stem completely. Adjust by turning in to slow the closing speed only as needed, but never more than three turns from fully closed. Tighten the locknuts on the speed controls

Troubleshooting

The following troubleshooting information in Tables deals strictly with the ZW209 and ZW209BP valve and pilot systems. It is recommended to verify that the pilot system is properly functioning before troubleshooting the main valve. All trouble shooting can be

⚠ **WARNING:** Cancer and Reproductive Harm - www.P65Warnings.ca.gov

⚠ **ADVERTENCIA:** Cáncer y daño reproductivo - www.P65Warnings.ca.gov

⚠ **AVERTISSEMENT:** Cancer et néfastes sur la reproduction - www.P65Warnings.ca.gov

Troubleshooting

performed without disassembly. It is also recommended to permanently install a model ZPI valve position indicator.

PILOT SYSTEM FUNCTION CHECK

1. To verify if the Pilot PRV is properly regulating pressure, first slowly close the downstream pilot and bypass ball valves in the pilot systems. Allow the cover to fill and the main valve to close. To close the valve, it may be necessary to open a downstream valve so there is flow going through the ZW209. If installed, verify the main valve is closed by checking the position indicator (model ZPI).
2. When the main valve is closed, close the cover ball valve to keep the main valve closed.
3. Proceed with venting outlet downstream pressure by opening a source downstream. When opening the downstream source if there is continuous flow, the main valve is not sealing properly (large systems may take longer to drop to zero pressure). It is recommended that the main valve be disassembled and inspected

for diaphragm damage, seal ring/seat damager or debris. (Refer to "Disassembly" section).

4. When downstream pressure is relieved, proceed with slowly closing the upstream pilot ball valve. Re-open the outlet ball valve to relieve pressure on the downstream gauge.
5. With the main valve closed and the system pressure relieved slowly re-open the upstream pilot ball valve and re-pressurize the pilot system only leaving downstream pilot ball valve closed. Monitor the inlet and outlet pressures and compare to the desired system settings. Static downstream pressure will be 5-10 psi above flowing pressure, this is normal. If the outlet pressure is the same as the inlet or climbs more than 10 psi above the flowing set point, the Pilot PRV is not properly regulating (refer to the troubleshooting Table 1. Corrective Action section).
6. If the pressure is regulating to the desired system pressures proceed with diagnosis checks for the main valve.

TABLE 1.

PROBLEM	POSSIBLE CAUSES	CORRECTIVE ACTION
1. Downstream pressure too high Note: Use "PILOT SYSTEM FUNCTION CHECK" in "Troubleshooting" section of instruction sheet to determine whether the issue is with the pilot or main valve.	1. Pilot ball valves closed 2. Air in main valve cover and/or tubing 3. "Wye" Strainer, orifice fitting, or a pipe in pilotry between inlet and cover is plugged 4. Inaccurate pressure gauge 5. Pilot PRV adjusted incorrectly or spring compressed solid 6. Mechanical obstruction in pilot PRV preventing valve from closing 7. Worn seal ring, o-ring, or damaged seat in pilot PRV 8. Mechanical obstruction under plunger or stem. 9. Foreign matter between rubber seal ring and seat, or worn rubber seal ring 10. Scale on stem or diaphragm ruptured 11. Worn or damaged stem o-rings	1. Open ball valves 2. Loosen top cover plug and fitting and bleed air out of the system 3. Remove, clean, and/or replace 4. Replace pressure gauge 5. Back off adjusting screw 6. Disassemble and remove obstruction 7. Remove and replace pilot PRV cartridge 8. Disassemble and remove obstruction 9. Disassemble the main valve, remove debris, clean parts, and replaced defective parts 10. Clean parts, and replace defective parts 11. Clean parts, and replace defective parts
2. Downstream pressure too low	1. No pressure at valve Inlet 2. Pilot ball valves closed 3. Pilot PRV adjusted incorrectly or no spring compression 4. SC1 opening speed control causes valve to open too slowly 5. Damaged spring in pilot PRV 6. Mechanical obstruction in pilot PRV preventing valve from opening 7. Clogged pipe in pilotry between cover and outlet 8. Mechanical obstruction in main valve between cover and diaphragm disc 9. Scale on main valve stem	1. Check Inlet pressure, check that upstream valves are open 2. Open ball valves 3. Tighten pilot PRV adjusting screw and/or inspect for corrosion 4. Turn the SC1 adjustment screw counterclockwise so valve responds quicker 5. Disassemble and replace 6. Disassemble pilot PRV and remove obstruction 7. Remove, clean, and/or replace 8. Disassemble and remove obstruction 9. Clean parts, and replace defective parts
3. Downstream pressure fluctuates rapidly	1. Air in main valve cover and/or tubing 2. Flow rate through valve is below minimum specified flow rate	1. Loosen top cover plug and fitting and bleed air out of the system 2 (a) Add SC1 opening speed control to pilotry system (see "O" in ZW209 Schematic). Turn SC1 opening speed control adjustment screw clockwise until fluctuations are at an acceptable level. 2 (b) If fluctuations are not at an acceptable level after 6(a), add low flow bypass. See ZW209BP spec sheet for information. 2 (c) If low flow bypass PRV is installed, increase PRV setting until fluctuations are acceptable. (Start at 5psi above ZW209 setting and increase if necessary)

When performing troubleshooting and diagnosis checks it is recommended that the following steps be performed in sequential order for best results.

DIAGNOSIS CHECKS

CAUTION: Do not service valve while under pressure. When performing diagnosis checks on the ZW209 & ZW209BP when the valve is fully open, high flow rates and high downstream pressures can occur. In order to prevent harm to personnel, equipment, and downstream piping be sure a downstream valve is closed before performing checks.

DIAPHRAGM CHECK

1. Slowly close upstream shut off valve and relieve all pressure downstream.
2. With all pressure relieved in the main valve, close both

upstream and downstream pilot ball valves. Remove side plug on cover and leave off.

3. Then open upstream shut off valve partially, allowing water to flow through the valve. While flowing water monitor the opening on the cover. Water will flow from the cover as the plunger assembly rises, if water continues to flow once fully open then there is most likely damage to the diaphragm or fluid is leaking past the diaphragm assembly due to loose assembly. It is recommended that the valve cover be removed to investigate the leakage (To remove cover see "Maintenance" section for procedures). If water stops flowing out of cover then the diaphragm is good and you may proceed to the diaphragm movement check.



DIAPHRAGM MOVEMENT CHECK

1. The diaphragm movement check can be determined during the diaphragm check by removing the top center plug or it can also be performed with the use of a valve position indicator model ZPI.
2. Replace cover plugs and open pilot ball valves on upstream and cover.
3. Closing the downstream pilot ball valves will direct the flow to the cover causing it to close. **NOTE: Slow or delayed closing of main valve is normal and is due to the time requirements to fill and pressurize cover, pushing the diaphragm into the closed position. This normal delay is not mechanical binding of the valve assembly.**
4. Using the valve position indicator, make note of the closed position on the indicator. Compare distance of the open mark to the close mark and compare to Table 3. (Or by measuring to the top of the stem under center plug before and after diaphragm check)
5. Verify that the main valve is closed, by opening a downstream source. If water continuously flows, then the main valve is not sealing properly. Double check the valve movement matches the values in Table 3 and refer to the disassembly procedures section if it does not. This is an indication that the main valve is not sealing due to an obstruction between the seat and the seal, stem or a damaged seal. If water does stop flowing and the measured valve movement does not match Table 3, then there is possible damage under the cover. Remove cover to identify obstruction and replace parts as necessary.

TABLE 3. VALVE STEM TRAVEL

VALVE SIZE (in)	VALVE SIZE (mm)	STEM TRAVEL (in)	STEM TRAVEL (mm)
1-1/4" - 1-1/2"	38	0.4	10.2
2"	50	0.7	18.0
2-1/2"	65	0.8	21.3
3"	80	0.9	23.4
4"	100	1.1	28.8
6"	150	1.7	43.4
8"	200	2.4	59.7
10"	250	2.8	71.1
12"	300	3.4	86.4
14"	350	3.8	96.5
16"	400	4.3	109.2

6. For smaller valves (6" and below) diaphragm checks can be performed by hand with the use of a valve stem tool. The valve stem tool can be made using Table 4 to create a "T" bar handle with the appropriate threads on the opposite end of the "T" handle.

TABLE 4. VALVE STEM THREAD SIZE

VALVE SIZE (in)	THREAD SIZE UNF INTERNAL
1-1/4" - 1-1/2"	10-32
2"	10 - 32
2-1/2"	10 - 32
3"	1/4 - 20
4"	1/4 - 20
6"	1/4 - 20
8"	3/8 -16
10"	3/8-16
12"	3/8-16
14"	3/8-16
16"	3/8-16

7. To perform the diaphragm check using the valve stem tool, first remove all pressure in the system and vent the cover. Then remove the center plug on the cover and insert tool into the top of the stem threads. Once the tool is inserted, the valve can be lifted up and the valve movement can be measured by creating marks on the tool in the opened and closed positions. The distance between marks is the valve stem travel. Replace or repair any parts as necessary. **Caution:** water will squirt from center hole or can be vented from extra plug on cover when lifting.

SEAL RING CHECK

1. To check the seal of the valve disc, an additional pressure gauge will be needed downstream of main valve. Also isolate low flow bypass line if equipped.
2. With the valve flowing, slowly, close downstream pilot ball valves to apply pressure to cover and allow to close.
3. Open downstream source to relieve all downstream pressure and then completely close downstream shutoff valve or downstream source to close downstream system. Monitor the pressure on the inlet and installed outlet gauge, for one min. The pressure on the outlet side should remain zero. If the pressure matches inlet pressure or increases, the main valve is leaking or the outlet ball valve on the pilot system is allowing pressure to creep by. Either way it is recommended that the valve be disassembled and inspected (refer to "Disassembly" section).

Maintenance Instructions

PREVENTATIVE MAINTENANCE

The Zurn Wilkins ZW200 models require minimal maintenance. However, it is highly recommended to schedule annual inspections and to have a repair kit on hand before work begins. Valves used often may be inspected on an annual basis, but at least every five years. Valves that rarely open, should be inspected every six months to one year for water deposits, debris, or corrosion.

DISASSEMBLY

Warning: Because of the ability to perform inspections and maintenance without removal from the system, it is very important that all shut off valves be closed and all pressure relieved in the valve before beginning disassembly. Failure to do so can result in personnel injury or equipment damage.

1. Verify that all pressure sources are closed up and downstream of valve.
2. Remove pressure in pilot system by loosening the tube fittings to the valve body and cover. When all pressure has been vented, continue to disassemble the pilot control valve and cover tubing. **NOTE:** Taking a picture before tear down can help with re-assembly of pilot system.
3. Next remove the cover by loosening and removing the cover bolts. If the cover does not come off easily it may be necessary to loosen the cover using a brass chisel and rubber mallet. Apply the chisel under the cover pointing upward away from valve body and tap bottom of cover with the chisel and mallet to loosen the cover. Once the cover is loose, pull cover straight up to avoid damaging the stem and stem bearing in the cover. On larger valves 8" and up, eye bolts and a hoist are recommended due to the weight of these larger covers.

4. With the cover removed the diaphragm assembly can be removed. To avoid damaging the seat bushing, grab the stem and lift straight up. For larger valves 8" and up it is recommended that an eye bolt with the proper stem threads be used with a hoist to lift the assembly out of the valve (see Table 4 for appropriate stem threads).
5. Next it is recommended that the diaphragm assembly be placed in a vise with the bottom hex secured. Once secured remove the spring and stem nut.
6. After inspecting the stem and removing the nut the diaphragm assembly can be dismantled. If the valve has not been serviced in awhile it is possible that the assembly will require the use of a rubber mallet or pry bars to dismantle the assembly. If this is the case gently tap or pry the components until the components are free to move. When disassembling be sure to clean, inspect, and save all components. Replace any damaged components as necessary.
7. The last component to inspect is the seat which is in the body of the main valve. During inspection of the seat, clean and polish as necessary with fine grit wet/dry sandpaper (400 grit or higher). Typically, if after cleaning there is no visual damage or excessive wear the seat should not require removal. If damage is present or the seat is excessively worn the seat should be replaced.
8. To remove the seat, on valves 6" and smaller the seat is threaded into the body and will require a seat removal tool. Care should be taken when removing the seat to avoid damaging. On 8" and larger valves, the seat is held in place with flat head hex screws. For larger valves a seat puller may be required to remove the seat from the body. A seat tool may be made by grinding three notches for the spokes in the end of a pipe. Turn with a pipe wrench.

INSPECTION OF COMPONENTS

Cleaning of components is required for proper inspection. Lime deposits are common in systems that use water. To remove deposits, fine grit wet/dry sandpaper (400 grit or higher) can be used. If deposits cannot be removed, off the shelf lime deposit remover can be used. Prepare a solution following the lime deposit remover instructions and soak components (excluding rubber components) until lime deposits are removed.

CAUTION: When handling chemicals (acids) be sure to use proper safety equipment (gloves and eye protection) and practices. After soaking components, be sure to thoroughly rinse all components before handling and re-assembling valve.

Once all valve components have been cleaned, inspect each component looking for damage, abnormal wear & corrosion, and replace all components that look questionable. Replace all rubber components including the diaphragm, o-rings and disc each time the valve is serviced or inspected (rubber components are standard in ZW200 repair kits).

REASSEMBLY

1. First reinstall seat into body. Be sure to use lube around seat o-ring before tightening. Tighten seat according to torque values in Table 5 using seat tool.
2. Next place valve stem in a vise clamping on the hex portion of the stem. Then assemble the diaphragm assembly as shown in Figure. When assembling be sure that the diaphragm is centered on the raised step of the disc retainer. It is also recommended to apply lube to stem threads and o-rings before tightening. Then tighten the stem nut according to Table 5 for torque values.
3. Lower diaphragm assembly carefully into the seat bushing. Be careful not to damage the seat or stem while installing assembly. Rotate the assembly as needed until the bolt holes on the diaphragm line up with the body bolt holes.
4. Place lower spring disc on the diaphragm disc and place spring on top of the assembly. Then install cover, aligning the bolt holes and insuring that the cover is not pinching the diaphragm between the bolt holes. Position cover so plug holes and pilot connection are in original position.
5. Install cover bolts and tighten in a star pattern to the torque values in Table 5.
6. Before installing center cover plug manually check that assembly has full operating travel before installing the pilot assembly (refer to "Diaphragm Movement" in the diagnosis checks section).
7. Once full operation range of the main valve is verified, begin reinstalling pilot system.
8. After installing pilot system double check that all plugs, bolts, and fittings are sealed and tight before applying pressure.
9. Slowly open upstream supply isolation valve to pressurize the system and check for any leaks.
10. Stop leaks as needed and proceed to "Start-Up" and "Diagnosis Check" sections for returning valve to proper system operations.

TABLE 5. VALVE TORQUE SETTINGS

VALVE SIZE (in)	COVER (ft-lbs)	DIAPHRAGM ASSEMBLY (ft-lbs)	THREADED SEAT (ft-lbs)	SEAT BOLTS (ft-lbs)
1-1/4"	3.5	7.5	11	N/A
1-1/2"	3.5	7.5	11	N/A
2"	15	20-25	30	N/A
2-1/2"	25	25-35	60	N/A
3"	25	35-45	70	N/A
4"	55	40-50	85	N/A
6"	110	50-60	95	N/A
8"	120	60-70	N/A	7.4
10"	184	70-75	N/A	7.4
12"	200	110-115	N/A	7.4
14"	275	170-175	N/A	7.4
16"	360	230-240	N/A	7.4

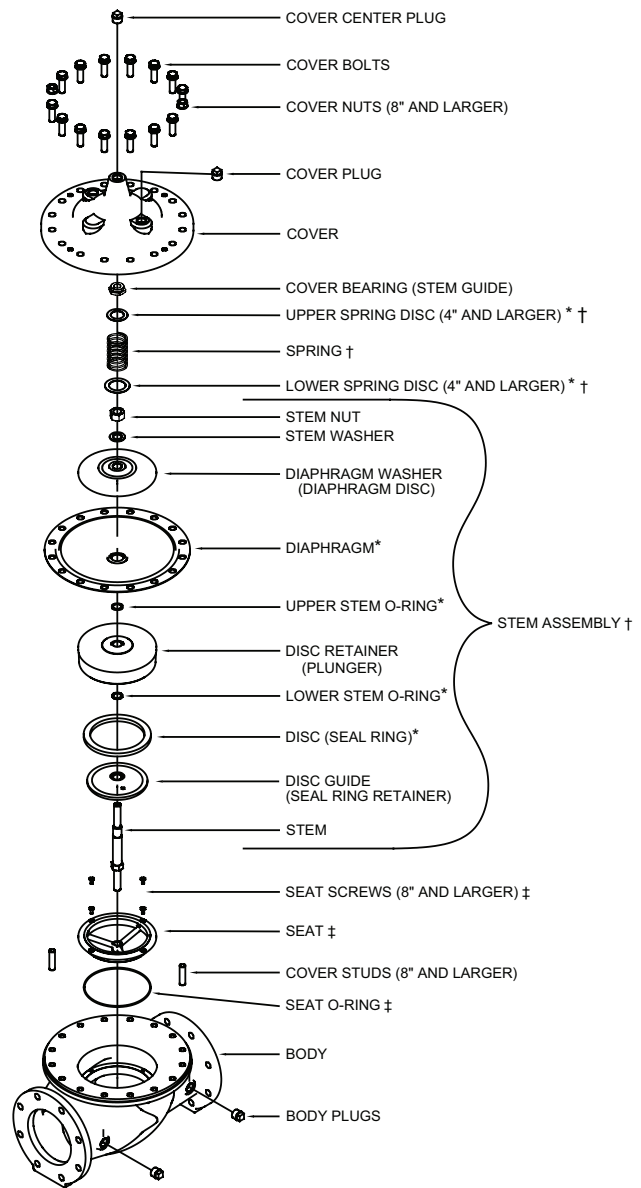

* RUBBER REPAIR KIT ITEMS
† COMPLETE REPAIR KIT ITEMS
‡ SEAT REPAIR KIT

Flow Characteristics

BODY MINIMUM FRICTION LOSS

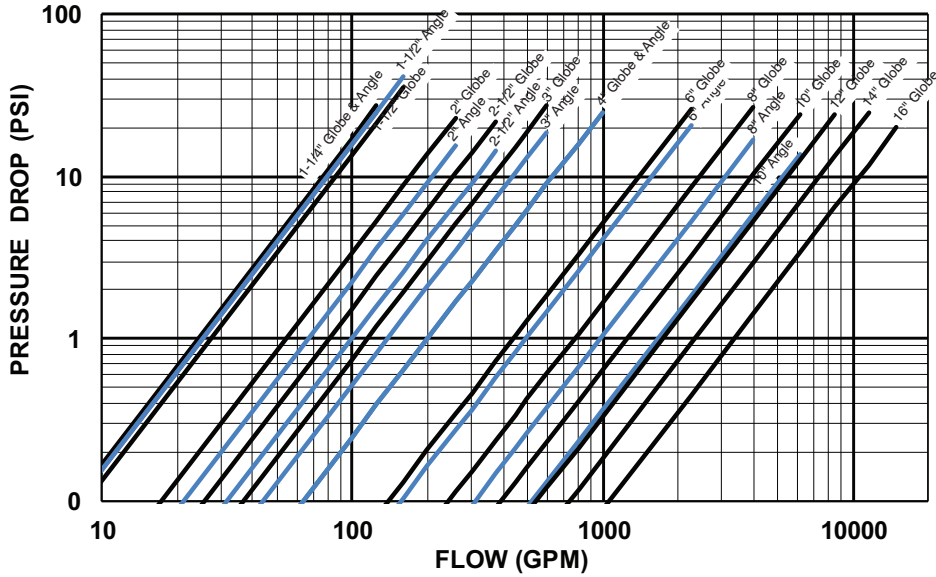

PRESSURE REDUCTION LIMIT

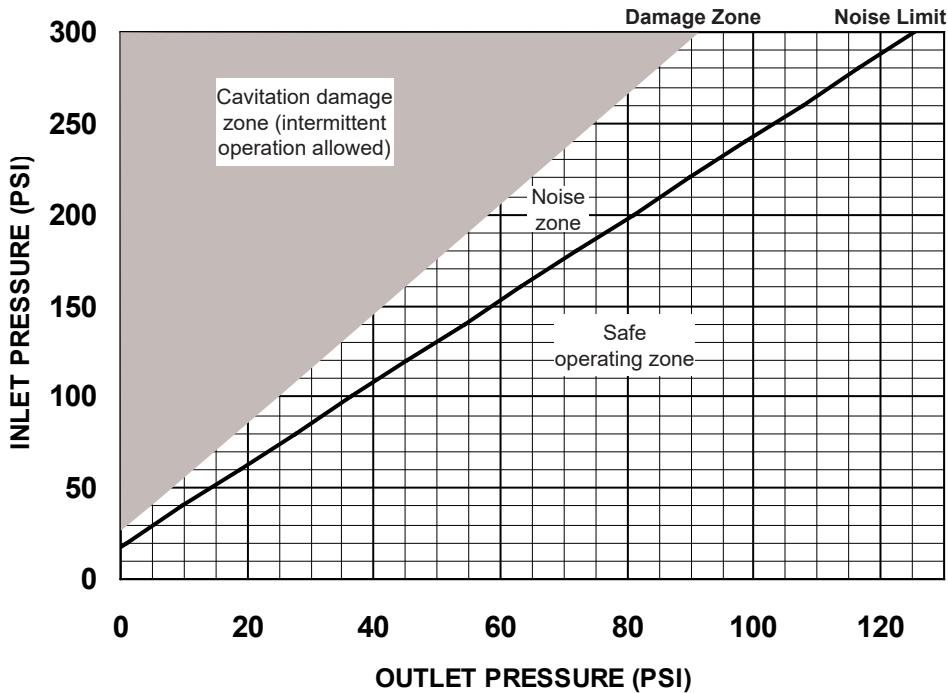

*** Notes for Body Minimum Friction Loss Chart:**

Minimum inlet pressure is 10 psi higher than set point or the additional body friction loss at intended flow, whichever is higher. (friction loss may be important at flows above 20 ft/s)

Example: A 6" valve intended to flow 2000 GPM at 150 psi has a friction loss of 20 psi at 2000 GPM. The minimum inlet pressure would be $150 + 20 = 170$ psi. When inlet pressure is below set point, the outlet pressure will be the pressure at the inlet minus the friction loss.

Model ZW209Q

LEAD-FREE*



Pressure Reducing Valve with Downstream Surge Protection

Globe and Angle Pattern Bodies

1 1/4", 1 1/2", 2", 2-1/2", 3", 4", 6", 8", 10", 12", 14" & 16"

*Contains a weighted average lead content less than 0.25% for wetted surfaces

□ Installation □ Troubleshooting □ Maintenance Instructions

Installation / Start-up

NOTE: Flushing of all pipe lines is to be performed to remove all debris prior to installing valve.

CAUTION: The recommended installation orientation for ACVs is horizontal, with the valve cover up. 6" and larger valves should only be installed horizontally, with the valve cover up, due to the difficulty of properly bleeding air out of the cover on valves installed in the vertical orientation. In addition, the horizontal positioning of the larger valves avoids premature wear due to the mass of plunger assemblies as well as allows for greater accessibility during annual inspections, and maintenance.

NOTE: If installation is subject to very low flow or potentially static conditions it is recommended a pressure relief valve (1/2" minimum) be installed downstream of the pressure reducing valve for additional system protection.

1. For making adjustments and servicing allow for adequate space around the valve before installing valve.
2. When installing a ZW209Q, gate valves installed on both inlet and outlet are recommended for maintenance allowing for isolation of valve.
3. Position the valve in line matching the direction of flow as indicated on the valve model tag with the proper direction of flow in the system. Once attached to line, double check all fasteners/bolts in the pilot system and on main valve are tight and there is no damage prior to pressurizing system.

NOTE: Pressure in some applications can be very high so be thorough in checking and inspecting for proper installation and makeup.

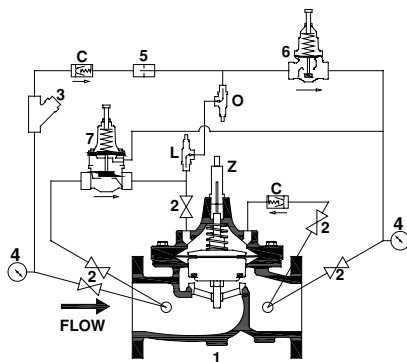

ZW209Q SCHEMATIC

STANDARD COMPONENTS

1. Main Valve
2. 850MXL Isolation Valve
3. SXL "Wye" Type Strainer
4. Pressure Gauge
5. Restriction Tube Fitting
6. PRXL Pressure Reducing Control
7. PV-RLF Pressure Relief Valve

OPTIONAL FEATURES

- C 40XL2 Hydraulic Check w/ Isolation Valve
- L SC1 Closing Speed Control
- O SC2 Opening Speed Control
- Z ZPI Valve Position Indicator

START-UP

CAUTION: To prevent personnel injury and damage to equipment check that downstream venting is adequate prior to start-up and test procedures.

All adjustments under pressure should be made slowly while under flowing conditions.

1. Open isolation valves (2) in the pilot system (see ZW209Q schematic).
2. Then slowly open the upstream shutoff valve only enough to fill main valve assembly and pilot system. Prior to pressurizing the valve assembly it is also recommended that a ZPI valve position indicator be installed to aid in verifying proper valve movement.
3. As the valve is filling with water, it is necessary to bleed the main valve and pilot system of air. To vent air, partially open or loosen the highest plugs or fittings in the system. The ZPI valve position indicator is a great location, as it has a test cock at the top to vent air pressure. It may be necessary to bleed system more than once. After removal of air in the system tighten all loose fittings. **NOTE: If valve is installed vertically, it will be necessary to loosen some upper cover bolts until you have vented all the air from the cover chamber.**
4. Before setting valve, if valve is equipped with SC1 Flow controls (O or L on ZW209Q schematic) it is necessary to completely back out the set screw.
5. Turn the surge protection pilot (relief pilot) adjustment screw clockwise until the pilot spring is compressed completely so the pressure reducing pilot can be set first.
6. At this point with the upstream shutoff valve open, slowly open the downstream shut off valve. Flow will begin to occur and pressure should build up in valve and eventually stabilize.
7. Next it is advisable to flow water through the valve to ensure all air has escaped from system. With water flowing through the valve, set the pressure reducing pilot 10 to 15 psi higher than the desired pressure reducing set pressure so the surge protection pilot can be set. To adjust the pressure reducing pilot, loosen jam nut on adjustment screw and either turn adjustment screw in (to increase outlet pressure) or out (to decrease outlet pressure).
8. Now set the surge protection pilot. With water still flowing through the main valve, start to turn the surge protection pilot adjustment screw counterclockwise until the downstream pressure drops 5 to 10 psi. Tighten the jam nut on the surge protection pilot.
9. Lower the downstream pressure to the desired setting by adjusting pressure reducing pilot. Once pilot is set, tighten the jam nut.
10. To verify proper operation of ZW209Q close and open downstream shut off valve several times to ensure downstream pressure is stable at set pressure.
11. After pilot system has been adjusted and the valve is properly regulating, the main valve opening and closing speed controls (O or L) can be adjusted as needed.
12. When setting speed controls, turning the adjustment screw into the speed control will restrict the amount of flow through the needle valve. Depending on whether the control is for opening or closing (refer to ZW209Q schematic) the control will either slow the opening or closing of the main valve when the adjustment screw is turned into the speed control. Adjust as needed and tighten jam nut.

⚠ **WARNING:** Cancer and Reproductive Harm - www.P65Warnings.ca.gov
⚠ **ADVERTENCIA:** Cáncer y daño reproductivo - www.P65Warnings.ca.gov
⚠ **AVERTISSEMENT:** Cancer et néfastes sur la reproduction - www.P65Warnings.ca.gov

Troubleshooting

The following troubleshooting information in Tables 1 - 3 deals strictly with the ZW209Q valve and pilot systems. It is recommended to verify that the pilot system is properly functioning before troubleshooting the main valve. All troubleshooting can be performed without removing the cover. It is also recommended to permanently install a model ZPI valve position indicator.

TABLE 1. PRESSURE REDUCING PILOT SYSTEM TROUBLESHOOTING

<u>PROBLEM</u>	<u>POSSIBLE CAUSES</u>	<u>CORRECTIVE ACTION</u>
1. Outlet Pressure Low	<ol style="list-style-type: none"> 1. No spring compression in Pilot 2. Damaged spring in Pilot 3. Clogged "Wye" Strainer 4. Closed ball valve 5. Relief Pilot set too low 	<ol style="list-style-type: none"> 1. Tighten adjusting screw 2. Disassemble and replace 3. Remove, clean, and/ or replace 4. Open ball valve 5. Turn Relief Pilot adjustment screw clockwise to raise set pressure.
2. Fails to Regulate (Outlet Pressure High)	<ol style="list-style-type: none"> 1. Mechanical obstruction 2. Worn disc (regulating>10 psi of flow set point) 	<ol style="list-style-type: none"> 1. Disassemble and remove obstruction, replace parts as necessary 2. Disassemble and replace disc
3. Pressure gauge fails to operate	<ol style="list-style-type: none"> 1. Damage pressure gauge 2. Closed ball valve 	<ol style="list-style-type: none"> 1. Replace pressure gauge 2. Open ball valve

TABLE 2. PRESSURE RELIEF/SURGE PROTECTION PILOT SYSTEM TROUBLESHOOTING

<u>PROBLEM</u>	<u>POSSIBLE CAUSES</u>	<u>CORRECTIVE ACTION</u>
1. Downstream pressure going high / Control valve not closing quickly	<ol style="list-style-type: none"> 1. Over compressed spring 2. Small pilot sense line clogged 3. Closed isolation ball valve 4. Worn diaphragm or stem o-ring 	<ol style="list-style-type: none"> 1. Loosen adjusting screw / Repeat start-up procedure 2. Disassemble and clean or replace 3. Open isolation ball valve 4. Disassemble and replace diaphragm or o-ring
2. Low downstream pressure / Control valve not opening	<ol style="list-style-type: none"> 1. Insufficient spring compression 2. Damaged spring 3. Worn seat seal or seat 4. Obstruction on seat 5. Obstruction around diaphragm 6. Worn seat o-ring 	<ol style="list-style-type: none"> 1. Tighten adjusting screw / Repeat start-up procedure 2. Disassemble and replace parts as necessary 3. Disassemble and replace seat seal or seat 4. Disassemble and remove obstruction 5. Disassemble and remove obstruction 6. Disassemble and replace as needed

TABLE 3. MAIN VALVE TROUBLESHOOTING

<u>PROBLEM</u>	<u>POSSIBLE CAUSES</u>	<u>CORRECTIVE ACTION</u>
1. Main Valve fails to open	<ol style="list-style-type: none"> 1. No pressure at valve Inlet 2. Main valve diaphragm assembly inoperative 3. Reducing or Relief Pilots are not opening 	<ol style="list-style-type: none"> 1. Check Inlet pressure 2. Disassemble, clean, and polish stem, replace defective parts 3. See Pilot Troubleshooting
2. Main Valve fails to close	<ol style="list-style-type: none"> 1. Foreign matter between disc and seat or worn disc 2. Scale on stem or diaphragm ruptured 3. "Wye" Strainer plugged 4. 38-850XL(ball valves) closed 5. Reducing or Relief Pilots remain open 	<ol style="list-style-type: none"> 1. Disassemble the main valve, remove debris, clean parts, and replaced defective parts 2. Clean parts, and replace defective parts 3. Remove, clean, and/or replace 4. Open ball valves 5. See Pilot Troubleshooting
3. Fails to Regulate	<ol style="list-style-type: none"> 1. Air in main valve cover and/or tubing 	<ol style="list-style-type: none"> 1. Loosen top cover plug and fitting and bleed air out of the system

When performing troubleshooting and diagnosis checks it is recommended that the following steps be performed in sequential order for best results.

Troubleshooting

PILOT SYSTEM FUNCTION CHECK

CAUTION: To prevent personnel injury and damage to equipment check that downstream venting is adequate prior to start-up and test procedures.

SURGE PROTECTION PILOT CHECK

1. With water flowing through the main valve turn the surge protection pilot (PV-RLF) adjustment screw clockwise all the way in.
2. While flowing close and open the cover isolation ball valve on the surge protection pilot while watching downstream pressure. If downstream pressure changes when opening and closing the cover isolation ball valve the pilot valve is not sealing properly. It is recommended that the pilot valve be disassembled and inspected.
3. Close the outlet isolation ball valve on the pressure reducing pilot. The main valve should close, after sometime. If installed, verify the valve position indicator (model ZPI) is closed.
4. If there is continuous flow from the outlet of the main valve, the main valve is not sealing properly. It is recommended that the main valve be disassembled and inspected (Refer to "Disassembly" section).
5. Open the outlet isolation ball valve on the pressure reducing pilot. The outlet pressure must be lower than the inlet pressure and water must be flowing through the main valve for the next steps 6-7.
6. Close all three isolation ball valves connected to the pressure reducing pilot. Close the cover isolation valve first, then the other two valves.
7. With all three surge protection isolation ball valves open, slowly turn the surge protection adjustment screw counter-clockwise until the outlet pressure starts to drop.
8. If the downstream pressure does not start to drop, the pilot valve is not opening properly. It is recommended that the surge pilot valve be disassembled and inspected.

PRESSURE PILOT REDUCING CHECK

1. With pressure on the inlet of the ZW209Q close the 3 isolation ball valves connecting to the surge protection pilot.
2. While flowing water slowly close the outlet ball valve in the pressure reducing pilot system. Allow the cover to pressurize and the main valve to close. If installed, verify the valve position indicator (model ZPI) is in a closed position.
3. Close the cover ball valve to keep the main valve closed.
4. Proceed with venting outlet downstream pressure by opening a source downstream. When opening the downstream source if there is continuous flow, the main valve is not sealing properly. It is recommended that the main valve be disassembled and inspected (Refer to "Disassembly" section).
5. With the main valve closed, open outlet isolation valve and allow a small amount of water to flow through the pilot valve by cracking open a downstream fitting. There should be continuous flow. If not, the pressure reducing pilot valve is not opening properly. It is recommended that the pilot valve be disassembled and inspected (Refer to appropriate pressure reducing pilot valve instruction sheet).
6. Monitor outlet pressure while cracking open and closing the downstream shutoff valve and compare to the desired system settings. If the outlet pressure is the same as the inlet pressure or climbs more than 15 psi above the flowing reduced pressure set point, the pressure reducing pilot is not properly regulating (refer to the pilot troubleshooting Pressure Reducing Pilot System Troubleshooting, Table 2. Corrective Action section).
7. If the pressure is regulating to the desired system pressures proceed with diagnosis checks for the main valve.

DIAGNOSIS CHECKS

CAUTION: Do not service valve while under pressure. When performing diagnosis checks on the ZW209Q when the valve is fully open, high flow rates and high downstream pressures can occur.

DIAPHRAGM CHECK

1. Slowly close upstream shut off valve and relieve all pressure downstream.
2. With all pressure relieved in the main valve, close both inlet and outlet isolation valves and remove side plug on cover and leave off.
3. Then open upstream shut off valve partially, allowing water to flow through the valve. While flowing water monitor the opening on the cover. If fluid begins to flow out of the open hole in the cover, then there is most likely damage to the diaphragm or fluid is leaking past the diaphragm assembly due to loose assembly. It is recommended that the valve cover be removed to investigate the leakage (To remove cover see "Maintenance" section for procedures). If no water flows out of cover then the diaphragm is good and you may proceed to the diaphragm movement check.

DIAPHRAGM MOVEMENT CHECK

1. The diaphragm movement check can be determined during the diaphragm check or it can also be performed with the use of a valve position indicator model ZPI.
2. Replace cover plug and open pilot ball valves on inlet and cover.
3. Closing the outlet isolation ball valves will direct the flow to the cover causing it to close. **NOTE: Slow or delayed closing of main valve is normal and is due to the time requirements to fill, pressurize cover, and stretch the diaphragm into the closed position. This normal delay is not mechanical binding of the valve assembly.**
4. Using the valve position indicator, make note of the closed position on the indicator. Compare distance of the open mark to the close mark and compare to Table 3.
5. Verify that the main valve is closed, by opening a downstream source (not the outlet isolation ball valve on the main body). If water continuously flows, then the main valve is not sealing properly. Double check the valve movement matches the values in Table 3 and refer to the disassembly procedures section if it does not. This is an indication that the main valve is not sealing due to an obstruction between the seat and the seal or a damaged seal. If water does stop flowing and the measured valve movement does not match Table 3, then there is possible damage under the cover. Remove cover to identify obstruction and replace parts as necessary.

TABLE 3. VALVE STEM TRAVEL

VALVE SIZE (in)	VALVE SIZE (mm)	STEM TRAVEL (in)	STEM TRAVEL (mm)
1-1/4" - 1-1/2"	38	0.4	10.2
2"	50	0.7	18.0
2-1/2"	65	0.8	21.3
3"	80	0.9	23.4
4"	100	1.1	28.8
6"	150	1.7	43.4
8"	200	2.4	59.7
10"	250	2.8	71.1
12"	300	3.4	86.4
14"	350	3.8	96.5
16"	400	4.3	109.2

Troubleshooting

6. For smaller valves (6" and below) diaphragm checks can be performed by hand with the use of a valve stem tool. The valve stem tool can be made using Table 4 to create a "T" bar handle with the appropriate threads on the opposite end of the "T" handle.

TABLE 4. VALVE STEM THREAD SIZE

VALVE SIZE (in)	THREAD SIZE UNF INTERNAL
1-1/4" - 1-1/2"	10-32
2"	10 - 32
2-1/2"	10 - 32
3"	1/4 - 20
4"	1/4 - 20
6"	1/4 - 20
8"	3/8 -16
10"	3/8-16
12"	3/8-16
14"	3/8-16
16"	3/8-16

7. To perform the diaphragm check using the valve stem tool,

first remove all pressure in the system and vent the cover. Then remove the center plug on the cover and insert tool into the top of the stem threads. Once the tool is inserted, the valve can be lifted up and the valve movement can be measured by creating marks on the tool in the opened and closed positions. The distance between marks is the valve stem travel. Replace or repair any parts as necessary.

SEAL CHECK

1. To check the seal of the valve disc, an additional pressure gauge will be needed downstream of main valve.
2. With the valve flowing, slowly, close pilot outlet ball valves to apply pressure to cover and allow to close.
3. Open downstream source and monitor the pressure on the inlet and installed outlet gauge, for one min. The pressure on the outlet side should remain zero. If the pressure matches inlet pressure or increases, the main valve is leaking or the outlet ball valve on the pilot system is allowing pressure to creep by. Either way it is recommended that the valve be disassembled and inspected (refer to "Disassembly" section).

Maintenance Instructions

PREVENTATIVE MAINTENANCE

The Zurn Wilkins ZW200 models require minimal maintenance. However, it is highly recommended to schedule annual inspections and to have a repair kit on hand before work begins.

DISASSEMBLY

Warning: Because of the ability to perform inspections and maintenance without removal from the system, it is very important that all shut off valves be closed and all pressure relieved in the valve before beginning disassembly. Failure to do so can result in personnel injury or equipment damage.

1. Verify that all pressure sources are closed up and downstream of valve.
2. Remove pressure in pilot system by loosening the tube fittings to the valve body and cover. When all pressure has been vented, continue to disassemble the pilot control valve and cover tubing. **NOTE:** Taking a picture before tear down can help with re-assembly of pilot system.
3. Next remove the cover by loosening and removing the cover bolts. If the cover does not come off easily it may be necessary to loosen the cover using a brass chisel and rubber mallet. Apply the chisel under the cover pointing upward away from valve body and tap bottom of cover with the chisel and mallet to loosen the cover. Once the cover is loose, pull cover straight up to avoid damaging the stem and stem bearing in the cover. On larger valves 8" and up, eye bolts and a hoist are recommended due to the weight of these larger covers.
4. With the cover removed the diaphragm assembly can be removed. To avoid damaging the seat bushing, grab the stem and lift straight up. For larger valves 8" and up it is recommended that an eye bolt with the proper stem threads be used with a hoist to lift the assembly out of the valve (see Table 4 for appropriate stem threads).
5. Next it is recommended that the diaphragm assembly be placed in a vise with the bottom hex nut secured. Once secured remove the spring and stem nut. While removing the nut inspect the stem threads. Clean stem with a wire brush if mineral deposits or corrosion are present.
6. After inspecting the stem and removing the nut the diaphragm assembly can be dismantled. If the valve has not been serviced

in a while it is possible that the assembly will require the use of a rubber mallet or pry bars to dismantle the assembly. If this is the case gently tap or pry the components until the components are free to move. When disassembling be sure to clean, inspect, and save all components. Replace any damaged components as necessary.

7. The last component to inspect is the seat which is in the body of the main valve. During inspection of the seat, clean and polish as necessary with fine grit wet/dry sandpaper (400 grit or higher). Typically, if after cleaning there is no visual damage or excessive wear the seat should not require removal. If damage is present or the seat is excessively worn the seat should be replaced.
8. To remove the seat, on valves 6" and smaller the seat is threaded into the body and will require a seat removal tool. Care should be taken when removing the seat to avoid damaging. On 8" and larger valves, the seat is held in place with flat head hex screws. For larger valves a seat puller may be required to remove the seat from the body.

INSPECTION OF COMPONENTS

Cleaning of components is required for proper inspection. Lime deposits are common in systems that use water. To remove deposits, fine grit wet/dry sandpaper (400 grit or higher) can be used. If deposits cannot be removed, off the shelf lime deposit remover can be used. Prepare a solution following the lime deposit remover instructions and soak components (excluding rubber components) until lime deposits are removed.

CAUTION: When handling chemicals (acids) be sure to use proper safety equipment (gloves and eye protection) and practices. After soaking components, be sure to thoroughly rinse all components before handling and re-assembling valve.

Once all valve components have been cleaned, inspect each component looking for damage, abnormal wear & corrosion, and replace all components that look questionable. Replace all rubber components including the diaphragm, o-rings and disc each time the valve is serviced or inspected (rubber components are standard in ZW200 repair kits).

Maintenance Instructions

REASSEMBLY

1. First reinstall seat into body. Be sure to use lube around seat o-ring before tightening. Tighten seat according to torque values in Table 5 using seat tool.
2. Next place valve stem in a vise clamping on the hex portion of the stem. Then assemble the diaphragm assembly as shown in Figure to the right. When assembling be sure that the diaphragm is centered on the raised step of the disc retainer. It is also recommended to apply lube to stem threads and o-rings before tightening. Then tighten the stem nut according to Table 5 for torque values.
3. Lower diaphragm assembly carefully into the seat bushing. Be careful not to damage the seat or stem while installing assembly. Rotate the assembly as needed until the bolt holes on the diaphragm line up with the body bolt holes.
4. Place lower spring disc on the diaphragm disc and place spring on top of the assembly. Then install cover, aligning the bolt holes and insuring that the cover is not pinching the diaphragm between the bolt holes. Position cover so plug holes are in original position.
5. Install cover bolts and tighten in a star pattern to the torque values in Table 5.
6. Before installing center cover plug manually check that assembly has full operating travel before installing the pilot assembly (refer to "Diaphragm Movement" in the diagnosis checks section).
7. Once full operation range of the main valve is verified, begin reinstalling pilot system.
8. After installing pilot system double check that all plugs, bolts, and fittings are sealed and tight before applying pressure.
9. Slowly open upstream isolation valve to pressurize the system and check for any leaks.
10. Stop leaks as needed and proceed to "Start-Up" and "Diagnosis Check" sections for returning valve to proper system operations.

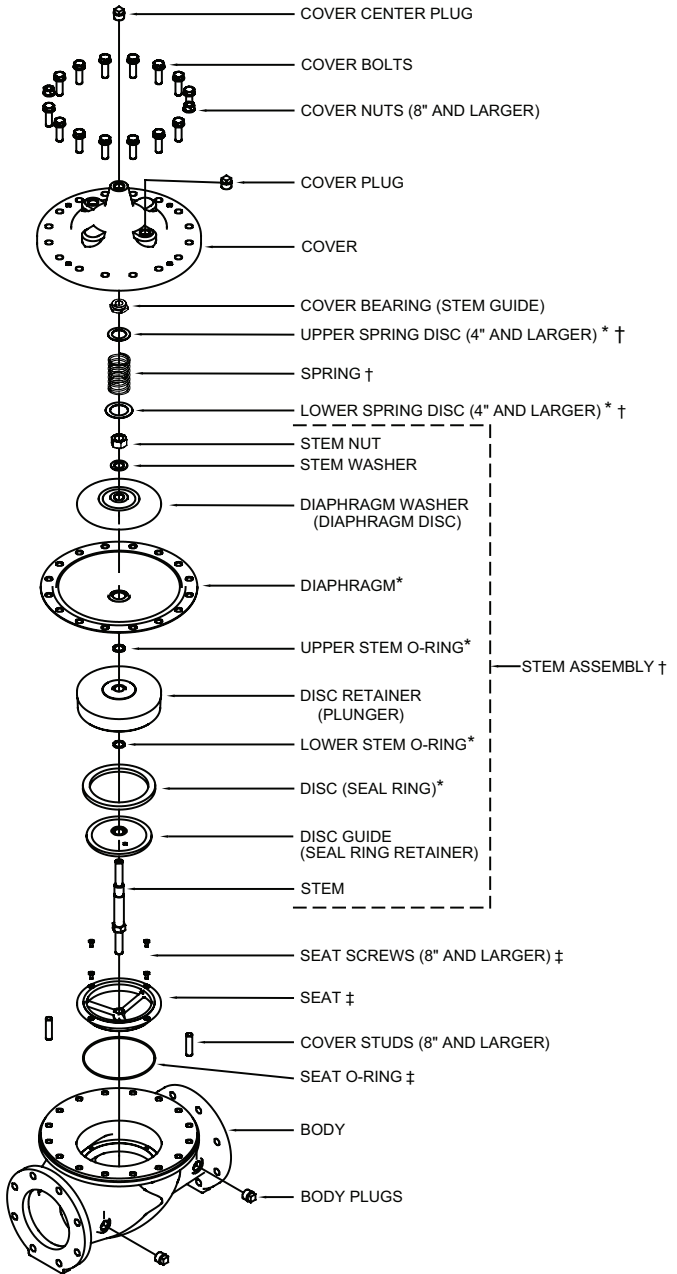

TABLE 5. VALVE TORQUE SETTINGS

VALVE SIZE (in)	COVER (ft-lbs)	DIAPHRAGM ASSEMBLY (ft-lbs)	THREADED SEAT (ft-lbs)	SEAT BOLTS (ft-lbs)
1-1/4"	3.5	7.5	11	N/A
1-1/2"	3.5	7.5	11	N/A
2"	15	20-25	30	N/A
2-1/2"	25	25-35	60	N/A
3"	25	35-45	70	N/A
4"	55	40-50	85	N/A
6"	110	50-60	95	N/A
8"	120	60-70	N/A	7.4
10"	184	70-75	N/A	7.4
12"	200	110-115	N/A	7.4
14"	275	170-175	N/A	7.4
16"	360	230-240	N/A	7.4

* RUBBER REPAIR KIT ITEMS
 † COMPLETE REPAIR KIT ITEMS
 ‡ SEAT REPAIR KIT

Maintenance (PV-RLF Valve)

The PV-RLF Pressure Relief Valve may be installed in any position. The flow direction is shown below. Flow goes from the narrow side to the wide side of the cast body.

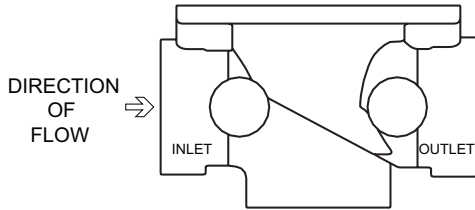

Disassembly

Prior to disassembly, relieve all pressure in pilot system and then remove the PV-RLF.

1. Secure valve body and turn the adjustment screw all the way out.
2. Next remove 8 socket head screws around the pilot bell using a 5/32" hex key. Remove the bell, the spring, and 2 spring discs.
3. Remove the spacer and remove small gasket from the bottom of the spacer. Use a 12mm socket or adjustable wrench on the diaphragm and plunger nuts to disassemble the plunger/diaphragm assembly. Unscrew one end of the stem.
4. At this point slide the plunger/diaphragm assembly out of the valve spacer.
5. Use soft jaws or a towel and pliers to clamp the stem. Be careful not to scratch the stem as this is an o-ring surface. Use an adjustable wrench on the opposite nut to remove the remaining plunger/diaphragm assembly.
6. The parts removed from the disassembled diaphragm and plunger assembly are a plunger, small washer, 2 o-rings, 2 nuts, a medium washer, a large washer, diaphragm, and lock washer.
7. Use a small pin or nail to carefully remove the o-ring on the inside through hole of the spacer.
8. After complete disassembly thoroughly clean and inspect all components before reassembly. Replace parts as necessary after inspection.
9. The pilot seat generally does not need to be removed, but if after inspection it requires replacement it can be removed with a 1-1/16" socket.

PV-RLF Valve

Reassembly

Reassembly of the PV-RLF is the reverse of disassembly.

1. Carefully install a new o-ring in the through hole of the spacer.
2. Place the medium washer (with round outer edge toward the diaphragm) on the side of the stem with the chamfered tip.
3. Follow the washer by putting on a new o-ring, new diaphragm, large washer (with the inner step against the diaphragm), lock washer, and 5/16" (chamfered side away from diaphragm) nut then hand tighten.
4. Slide the stem through the spacer with the diaphragm assembly on the spacer side with a circular groove on the top surface.
5. On the other side of the stem place the small washer, o-ring, plunger (with the rubber facing away from the spacer), and nut.

6. Use adjustable wrenches to tighten the plunger and diaphragm nuts.
7. Place small gasket on bottom of valve spacer.
8. Install the plunger assembly on to the body with the plunger sitting on the valve seat. The small rubber gasket on the plunger side of the spacer must cover the sensing hole on the pilot body.
9. Place a spring disk on the stem, then the spring, another spring disk and bell.
10. Insert socket head cap screws into pilot bell holes and thread into valve body. Place model tag on the four screws that straddle the body inlet. Tighten all screws in a cross pattern.
11. Install adjusting screw by hand with jam nut. Set valve once reinstalled into pilotry system. Refer to "Start-up" section on page one for proper setting of relief pilot. For further assistance or ordering replacement parts go to www.zurn.com or call product support 877-222-5356.

Table 1

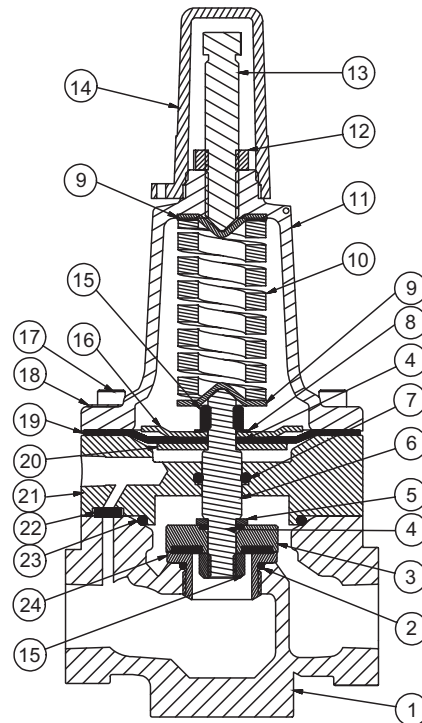

ITEM	DESCRIPTION
1	1/2" Relief Body
2	O-ring Buna Nitrile, NSF Listed
3	Relief Plunger Assy.
4	Diaphragm O-ring
5	5/16" Flat Washer
6	Relief Pilot Stem
7	O-ring, Buna Nitrile, NSF Listed
8	5/16" Internal Tooth Lock Washer
9	Spring Disc
10	Spring
11	Pilot Bell
12	3x8-16 Jam Hex Nut

ITEM	DESCRIPTION
13	3/8-16 Adjustment Bolt
14	Adjustment Cover
15	5/16-18 Diaphragm Nut
16	Relief Pilot Upper Diaphragm Disc, SS
17	10-32 X 1-1/2" Skt Hd Cap Screw, SS
18	Tag
19	Diaphragm
20	Relief Pilot Lower Diaphragm Washer
21	Relief Pilot Spacer
22	Sensing Hole Gasket
23	O-ring, Buna Nitrile, NSF Listed
24	Relief Pilot Seat

FLOW CHARACTERISTICS

BODY MINIMUM FRICTION LOSS

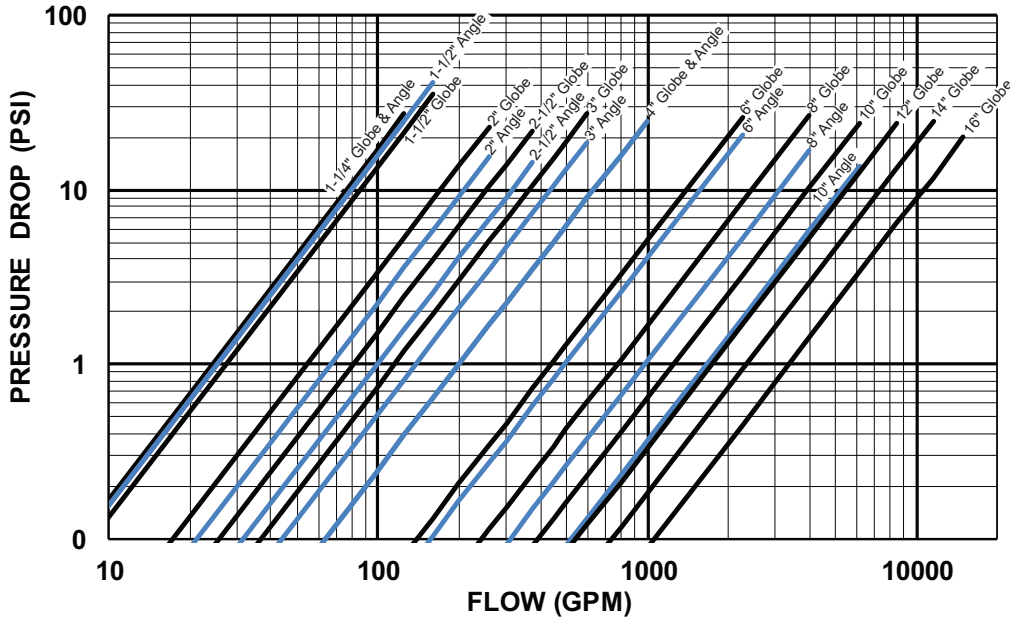

PRESSURE REDUCTION LIMIT

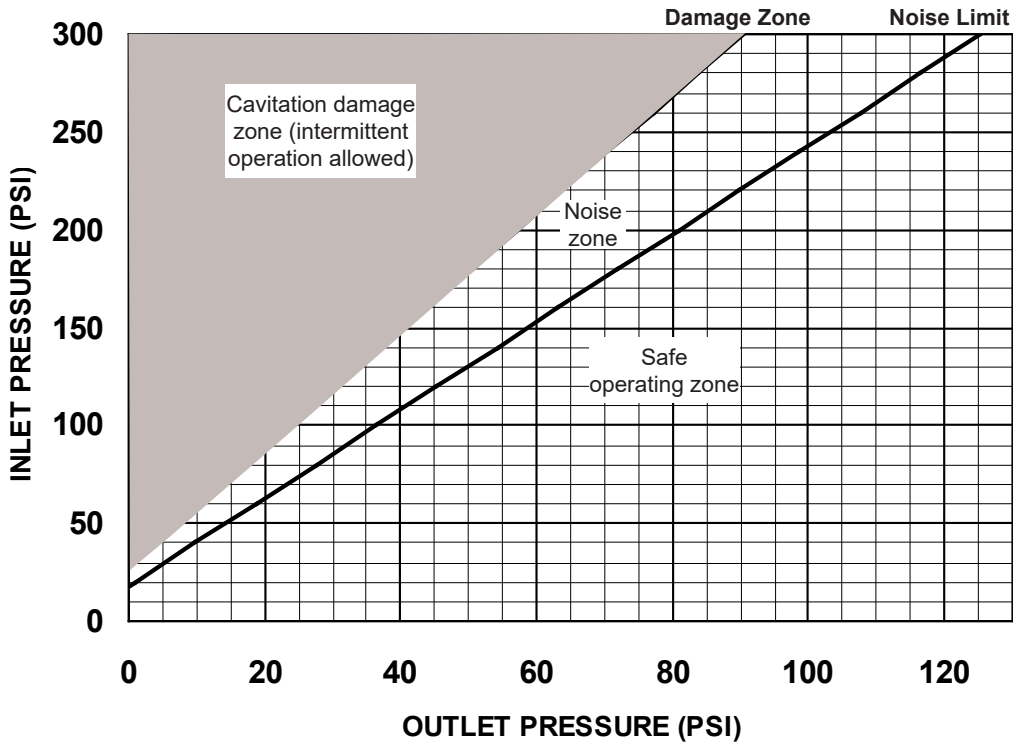

*** Notes for Body Minimum Friction Loss Chart:**

Minimum inlet pressure is 10 psi higher than set point or the additional body friction loss at intended flow, whichever is higher. (friction loss may be important at flows above 20 ft/s)

Example: A 6" valve intended to flow 2000 GPM at 150 psi has a friction loss of 20 psi at 2000 GPM. The minimum inlet pressure would be 150 + 20 = 170 psi. When inlet pressure is below set point, the outlet pressure will be the pressure at the inlet minus the friction loss.