

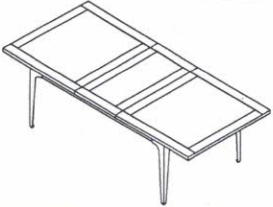



HEKMAN®

X A HOWARD MILLER COMPANY

23820 RECT. DINING TABLE

Hardware List

A	B	C	D	
ALLEN BOLT M8 X 70 (8 PCS.)	FLAT W. M8 8 PCS.	SPRING W. M8 8 PCS.	ALLEN KEY L5 (FOR ALLEN BOLT) 1 PC.	
				

Assembly Instruction

STEP 1.

LAY TOP PANEL UPSIDE DOWN ON A SOFT, CLEAN AND FLAT SURFACE. ALIGN BOLTS OF LEGS TO HOLES ON TOP PANEL AND CONNECT USING FLAT WASHER (B), SPRING WASHER (C), ALLEN BOLT (A) AND ALLEN KEY (D) PROVIDED.

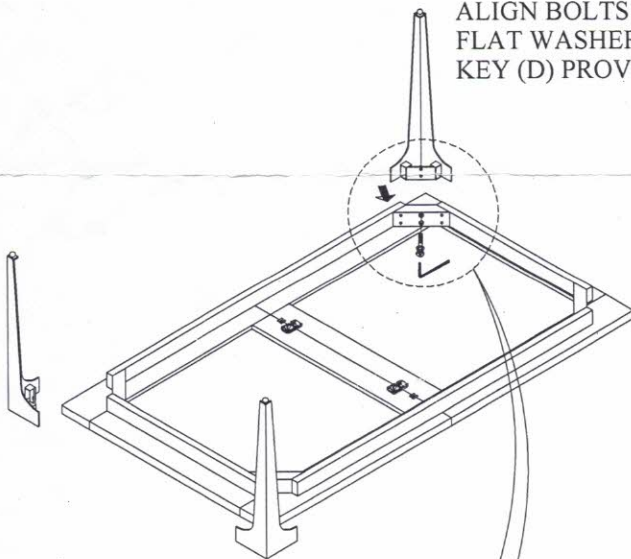

STEP 2:

TURN ASSEMBLED TABLE UPWARD.

* TO ATTACH EXTENSION LEAF, UNLOCK TABLE LOCKS UNDER THE TOP, SLIDE TABLE TOP HALVES APART AND PLACE EXTENSION LEAF TO THE OPENING AT RIGHT POSITION. SLIDE TOP HALVES TO HOLD EXTENSION LEAF IN PLACE AND LOCK AGAIN THE TABLE LOCK.

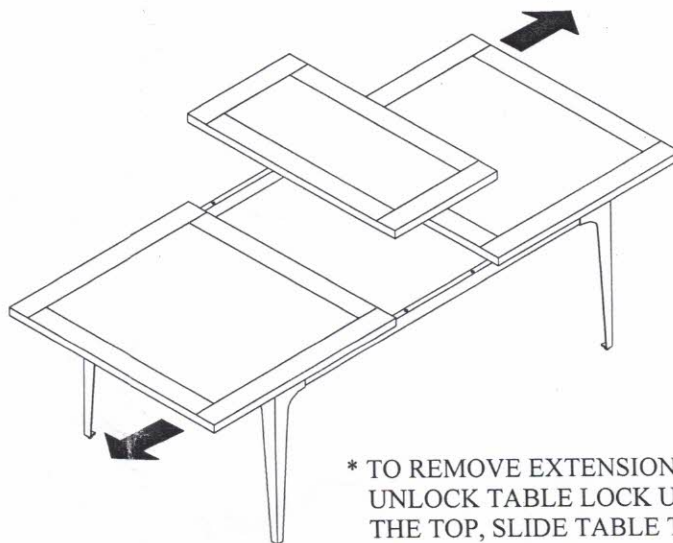

* TO REMOVE EXTENSION LEAF, UNLOCK TABLE LOCK UNDER THE TOP, SLIDE TABLE TOP HALVES APART. REMOVE EXTENSION LEAF (G) AND SLIDE TOP HALVES TOGETHER.

