

# SLOAN® Water Closet Installation Instructions

Water Connects Us®

## THE RIGHT CHOICE

We thank you for your purchase. Our products are 100% tested but should you have any questions, please contact us by phone or at our web site.



**⚠ WARNING: Any vitreous china can chip or break if the bolts or nuts are over-tightened or if mishandled.**

### BEFORE YOU START...

- Check all local plumbing and building codes.
- Check for any damage to the new water closet before installation.

### WHAT YOU WILL NEED...

- Putty knife
- Safety glasses
- Measuring tape
- Spud wrench
- Sponge
- 10" adjustable wrench
- Large level
- Wax seal

### NOTE: Plumbing System Requirements

- ✓ Minimum Flowing Pressure: 25 PSI
- ✓ Minimum Flow Rate: 25 GPM
- ✓ Maximum Static Pressure: 80 PSI

## 1. REMOVAL OF EXISTING WATER CLOSET

- Turn off the water supply.
- Disconnect the flush valve.
- Remove the existing water closet.

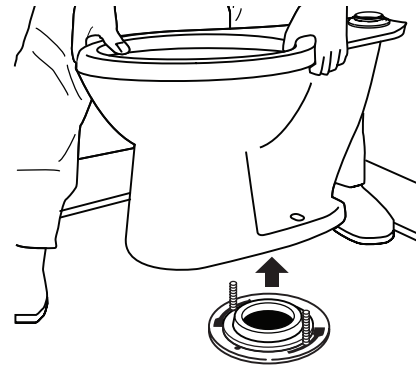

- Using putty knife, completely remove old wax seal from floor and bottom of water closet.
- Lay water closet down on padded surface to help protect the vitreous china.



**⚠ WARNING: Hazardous gases can escape through the closet flange if new water closet is not installed quickly. A temporary fix: place a large rag in the closet flange.**

**NOTE:** All vitreous china dimensions shown in these drawings are nominal. Dimensions can vary within the tolerances established in the governing ASME A112.19.2/CSA B45.1 standard. Please take this into consideration when planning rough-in and plumbing layouts.

## 2. INSTALLING NEW WATER CLOSET

- Check rough-in dimensions and install or relocate flush valve and outlet as indicated.
- Record model number for reference.
- Place and press in a new wax seal around the water closet bottom outlet.
- Install new 5/16 "T-bolts.

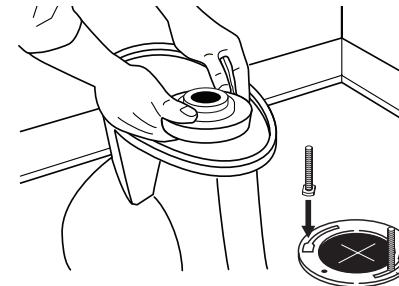

- Take out the temporary rag (if used) from the water closet flange hole.
- Carefully align and lower the water closet over the flange and T-bolts.

**IMPORTANT! Do not lift or rock the water closet after replacement. The watertight seal will have to be replaced if breakage occurs.**



- To seal, apply your full body weight around the water closet.
- Place the plastic cap base in the position indicated on cap as marked.
- The metal washers and nuts can now be placed on the bolt cap base and T-bolts.



- Tighten the nuts carefully.

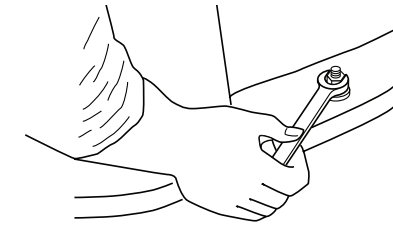

**⚠ IMPORTANT! Do not overtighten the nuts, breakage and chipping of vitreous china can occur.**

- Cut 1/4" or more over the top of the nut.
- Attach the bolt caps.

**⚠ IMPORTANT! Product damage can occur if using a saw blade to cut off the excess T-bolt length. Make sure vitreous china is protected and covered.**

## 3. COMPLETING THE INSTALLATION

- Flush valve should be installed to manufacturer's installation instructions.
- Turn on water supply valve.
- Install toilet seat (not included).

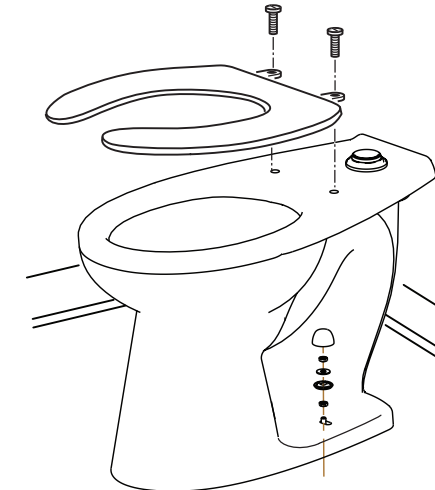

- Flush water closet a few times and check all connections for water seepage.
- Check for leaks.

## CARE AND CLEANING OF VITREOUS CHINA

Clean water closet with a cleaner safe for vitreous china. Spray and wipe clean using soft cloth. Soft abrasive cleaners may be used to remove stains.

## LIMITED WARRANTY

Sloan Valve Company warrants its products to be made of first class materials, free from defects of material or workmanship under normal use and to perform the service for which they are intended in a thoroughly reliable and efficient manner when properly installed and serviced, for a period of three years (one year for special finishes) from date of purchase. During this period, Sloan Valve Company will, at its option, repair or replace any part or parts which prove to be thus defective if returned to Sloan Valve Company, at customer's cost, and this shall be the sole remedy available under this warranty. No claims will be allowed for labor, transportation or other incidental costs. This warranty extends only to persons or organizations who purchase Sloan Valve Company's products directly from Sloan Valve Company for purpose of resale.

**THERE ARE NO WARRANTIES WHICH EXTEND BEYOND THE DESCRIPTION ON THE FACE HEREOF. IN NO EVENT IS SLOAN VALVE COMPANY RESPONSIBLE FOR ANY CONSEQUENTIAL DAMAGES OF ANY MEASURE WHATSOEVER.**

**NOTE: IN NO EVENT SHALL THE SLOAN VALVE COMPANY BE LIABLE FOR INCIDENTAL DAMAGES, RESULTING FROM IMPROPER INSTALLATION, OR FOR DAMAGES CAUSED BY NEGLIGENCE, ABUSE OR ALTERATION.**

The information contained in this document is subject to change without notice.

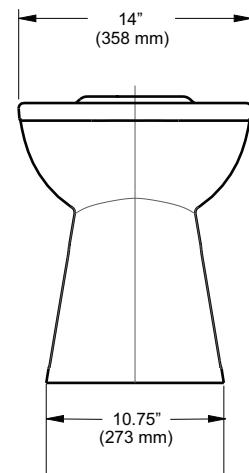
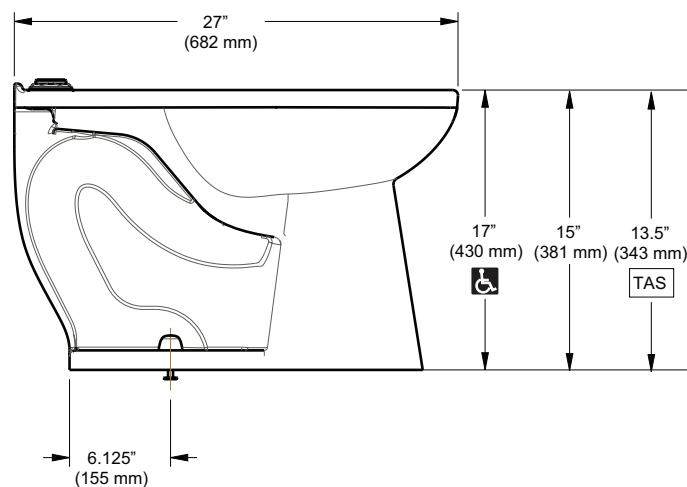
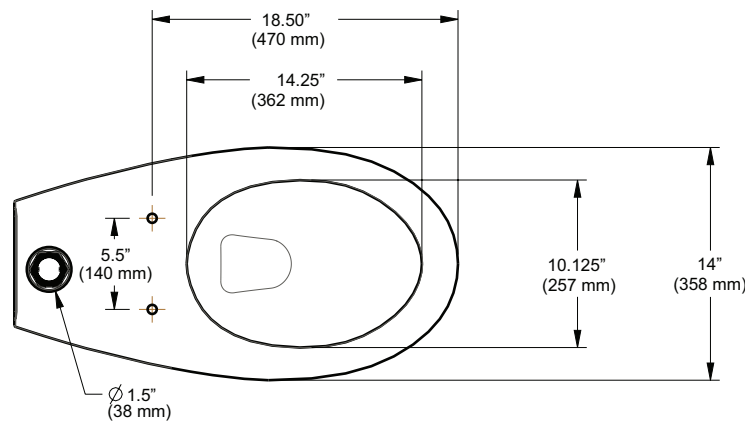

**TO MAXIMIZE THE PERFORMANCE OF YOUR SLOAN WATER CLOSET, USE ONLY SLOAN FLUSHOMETERS**

**SLOAN®**

## SLOAN

10500 Seymour Avenue  
Franklin Park, IL 60131  
Phone: 1-800-9-VALVE-9 (982-5839)  
or 1-847-671-4300  
Fax: 1-800-447-8329 or 1-847-671-4380  
www.sloan.com

Copyright © 2017 Sloan Valve Company  
Printed in the U.S.A.  
Code No. 0816691 Rev.2 (03-17)

# SLOAN® Instalación de Sanitario

Water Connects Us®

## LA ELECCIÓN CORRECTA

Le agradecemos su compra. Nuestros productos son probados al 100%, sin embargo, si tiene alguna duda, contáctenos por teléfono o en nuestro sitio web.



**⚠️ ADVERTENCIA:** Cualquier porcelana puede desconcharse o romperse si los pernos o tuercas se aprietan de más o si son mal manipulados.

- Revise los códigos locales de plomería y construcción.
- Revise si el nuevo sanitario presenta daños antes de instalarlo.

### LO QUE USTED NECESITA...

- Espátula
- Esponja
- Lentes de Seguridad
- Llave ajustable de 10
- Cinta para medir
- Nivel grande
- Llave para spud
- Sello de cera

### NOTA: Requisitos del sistema de plomería

- ✓ Presión mínima de flujo: 25 PSI
- ✓ Caudal mínimo: 25 GPM
- ✓ Máxima presión estática: 80 PSI

## 1. REMOVER EL SANITARIO EXISTENTE.

- Apague la alimentación de agua.
- Desconecte la válvula de descarga.
- Remueva el sanitario existente.

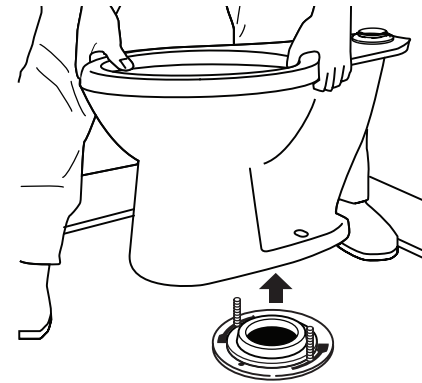

- Utilizando una espátula, remueva completamente el sello de cera anterior del piso y la parte inferior del sanitario.
- Coloque el sanitario en una superficie acolchada para ayudar a proteger la porcelana.



**⚠️ ADVERTENCIA:** Gases peligrosos pueden escapar por el chapetón del sanitario si el nuevo sanitario no se instala rápidamente. Revise los códigos locales de plomería. Una solución temporal: coloque un trozo grande de tela en el chapetón de sanitario.

**NOTA:** Todas las dimensiones mostradas en estos dibujos son nominales. Las dimensiones pueden variar dentro de las tolerancias establecidas en la norma ASME A112.19.2/CSA B45.1. Por favor tenga esto en cuenta al planificar la preparación y diseños de plomería.

## 2. INSTALAR EL NUEVO SANITARIO

- Revise las dimensiones de preparación e instale o vuelva a colocar la válvula de descarga y la salida como se indica.
- Guarde el número de modelo como referencia.
- Coloque y presione el nuevo sello de cera alrededor de la salida en la parte inferior del sanitario.
- Instale pernos-T nuevos de 5/16".

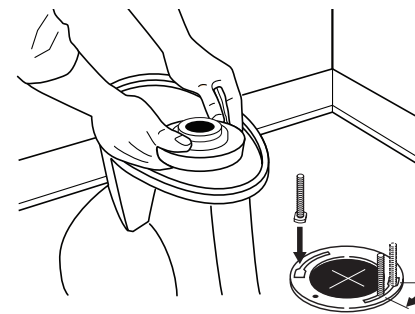

- Retire la tela temporal (si se usó) del agujero de chapetón del sanitario.
- Alinee y baje el sanitario cuidadosamente sobre el chapetón y los pernos T.
- **⚠️ IMPORTANTE:** No levante ni meza el sanitario después de volver a colocarlo. El sello de agua deberá reemplazarse si ocurre una ruptura.



- Para sellar, aplique el peso completo de su cuerpo alrededor del sanitario.
- Coloque la tapa de plástico en la posición que se indica en la tapa.
- Las arandelas y tuercas metálicas pueden colocarse en la base de la tapa de pernos y en los pernos.



- Apriete las tuercas cuidadosamente

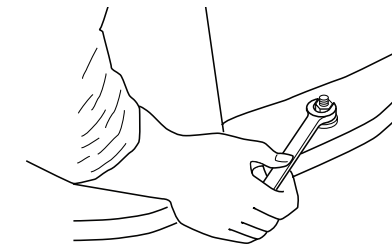

**⚠️ IMPORTANTE!** No apriete de más las tuercas, puede ocurrir ruptura o desconchar la porcelana.

- Corte 1/4" o más sobre la parte superior de la tuerca.
- Coloque las tapas de perno.

**⚠️ IMPORTANTE!** Puede ocurrir daño al producto si se usa una hoja de sierra para cortar la longitud excesiva del perno T. Asegúrese que la porcelana esté protegida y cubierta.

## 3. COMPLETAR LA INSTALACIÓN

- La válvula de descarga debe ser instalada de acuerdo con las instrucciones de instalación del fabricante.
- Abra la válvula de alimentación de agua.
- Instale el asiento del sanitario (no incluido).

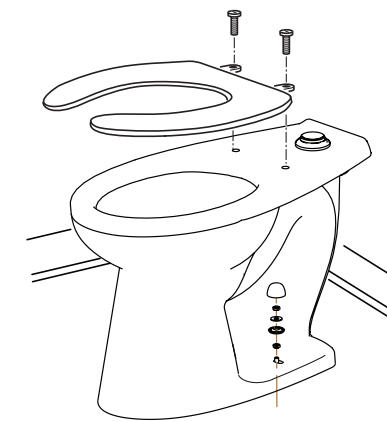

- Descargue el sanitario unas cuantas veces y revise todas las conexiones en busca de filtraciones de agua.
- Revise si existen fugas por unos cuantos días.

## CUIDADO Y LIMPIEZA DE LA PORCELANA

Limpie los sanitarios con un limpiador seguro para porcelana y limpie y seque utilizando un trapo suave. Pueden utilizarse limpiadores abrasivos suaves para remover manchas.

## GARANTÍA LIMITADA

Sloan Valve Company garantiza que sus Productos están hechos de materiales de primera clase, libres de defectos en el material o en la fabricación, bajo uso normal y para llevar a cabo el servicio para el cual se han fabricado, en una forma totalmente eficiente confiable siempre que se instalen adecuadamente y se les dé el servicio adecuado, por un período de tres años (un año para acabados especiales) a partir de la fecha de compra. Durante este periodo Sloan, a su discreción, reparará o reemplazará cualquier parte o partes que se comprueben que estén defectuosas si se devuelven a Sloan, a costo del cliente, y este será el único recurso correctivo que se ofrece con esta garantía. No se aceptarán reclamos por mano de obra, transporte u otros costos incidentales. La presente garantía se extiende únicamente a personas u organizaciones que compren los productos de Sloan Valve Company directamente de Sloan Valve Company con fines de reventa.

**NO EXISTEN MÁS GARANTÍAS QUE SE EXTIENDAN MAS ALLÁ DE LA QUE SE DESCRIBIÓ ANTERIORMENTE. EN NINGÚN CASO SLOAN VALVE COMPANY ES RESPONSABLE POR CUALQUIER DAÑO CONSECUENTE DE CUALQUIER CLASE.**

**NOTA:** EN NINGÚN CASO SLOAN VALVE COMPANY SERÁ RESPONSABLE POR DAÑOS INCIDENTALES, RESULTADO DE INSTALACIÓN INADECUADA, O POR DAÑOS CAUSADOS POR NEGLIGENCIA, ABUSO O ALTERACIÓN.

La información contenida en este documento está sujeta a cambios sin previo aviso.

**SLOAN®**

## SLOAN

10500 Seymour Avenue  
Franklin Park, IL 60131  
Teléfono: 1-800-9-VALVE-9 o 1-841-671-4300  
Fax: 1-800-447-8329 o 1-847-671-4380  
www.sloan.com

Copyright © 2017 Sloan Valve Company  
Impreso en EE.UU.  
Code No. 0816691 Rev.2 (03-17)

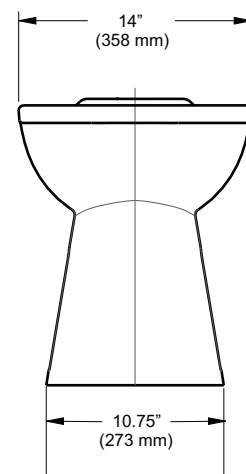
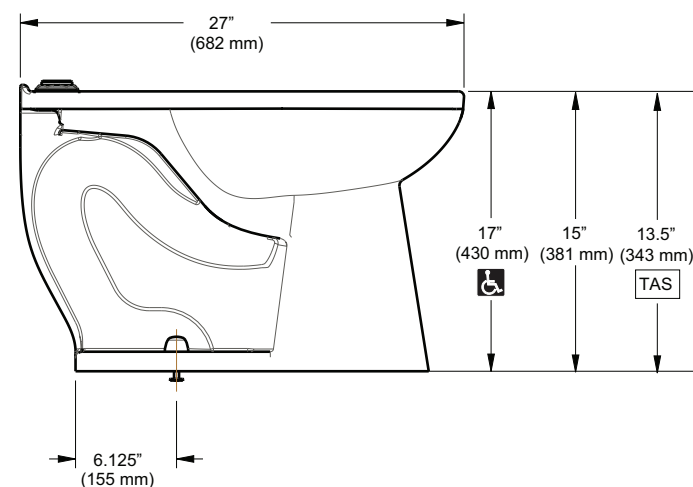
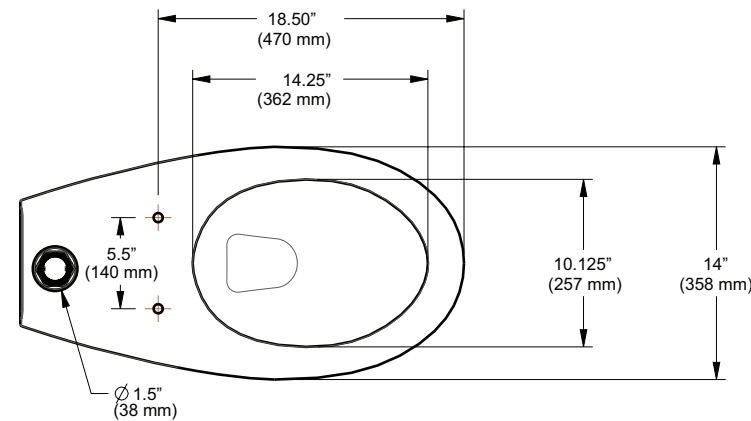

**PARA MAXIMIZAR EL DESEMPEÑO DE SU SANITARIO SLOAN, USE ÚNICAMENTE FLUXÓMETROS SLOAN**

## INSTALLATION INSTRUCTIONS FOR DUAL-FLUSH FLUSHOMETERS



**WES-111**  
Exposed Closet  
Flushometer  
for 1-1/2 Top Spud

### EXPOSED TOP SPUD 1½" WATER CLOSET

- MODEL 111
- MODEL 113
- MODEL 115
- MODEL 116

### EXPOSED REAR SPUD 1½" WATER CLOSET

- MODEL 120

### LIMITED WARRANTY

Unless otherwise noted, Sloan Valve Company warrants this product, manufactured and sold for commercial or industrial uses, to be free from defects in material and workmanship for a period of three (3) years (one (1) year for special finishes, SF faucets, PWT electronics and 30 days for PWT software) from date of first purchase. During this period, Sloan Valve Company will, at its option, repair, replace, or refund the purchase price of any product which fails to conform with this warranty under normal use and service. This shall be the sole and exclusive remedy under this warranty. Products must be returned to Sloan Valve Company, at customer's cost. No claims will be allowed for labor, transportation or other costs. This warranty extends only to persons or organizations who purchase Sloan Valve Company's products directly from Sloan Valve Company for purpose of resale. This warranty does not cover the life of the batteries.

**THERE ARE NO WARRANTIES WHICH EXTEND BEYOND THE DESCRIPTION ON THE FACE HEREOF. IN NO EVENT IS SLOAN VALVE COMPANY RESPONSIBLE FOR ANY CONSEQUENTIAL DAMAGES OF ANY MEASURE WHATSOEVER.**

## PRIOR TO INSTALLATION

Before you install the flushometer, be sure the items listed below are installed. Also, refer to the rough-in diagram below.

- Closet fixture
- Drain line
- Water supply line

### IMPORTANT:

- **ALL PLUMBING SHOULD BE INSTALLED IN ACCORDANCE WITH APPLICABLE CODES AND REGULATIONS.**

- **WATER SUPPLY LINES MUST BE SIZED TO PROVIDE AN ADEQUATE VOLUME OF WATER FOR EACH FIXTURE.**
- **FLUSH ALL WATER LINES PRIOR TO MAKING CONNECTIONS.**

Sloan's flushometers are designed to operate with 10 to 100 psi (69 to 689 kPa) of water pressure. **THE MINIMUM PRESSURE REQUIRED TO THE VALVE IS DETERMINED BY THE TYPE OF FIXTURE SELECTED.** Consult fixture manufacturer for minimum pressure requirements. Most Low Consumption water closets (1.6 gpf/6.0 Lpf) require a minimum flowing pressure of 25 psi (172 kPa).

## TOOLS REQUIRED FOR INSTALLATION

- Straight blade screwdriver
- Sloan A-50 Super-Wrench™, Sloan A-109 Plier Wrench or smooth jawed spud wrench

## ROUGH-IN

### MODELS 111, 113, 114, 115, 116

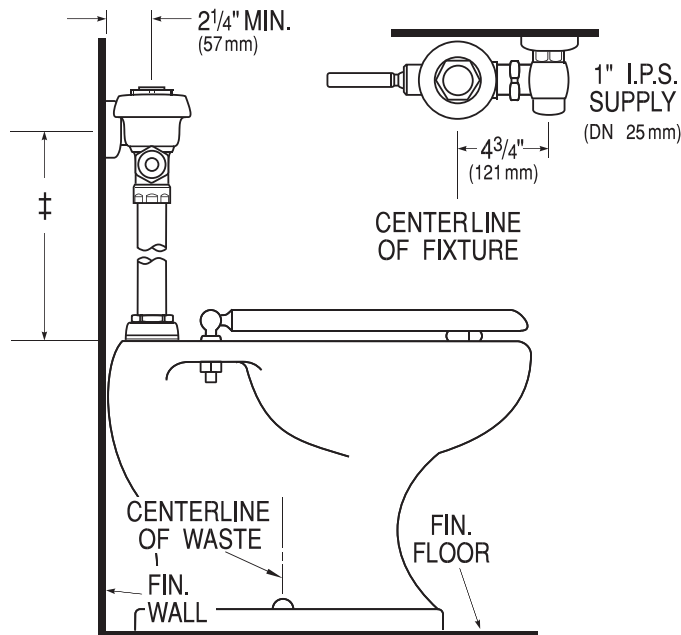

- |                             |                          |
|-----------------------------|--------------------------|
| ‡ Model 111 – 11½" (292 mm) | Model 115 – 24" (610 mm) |
| Model 113 – 16" (406 mm)    | Model 116 – 27" (686 mm) |
| Model 114 – 34⅜" (873 mm)   |                          |

### MODEL 120

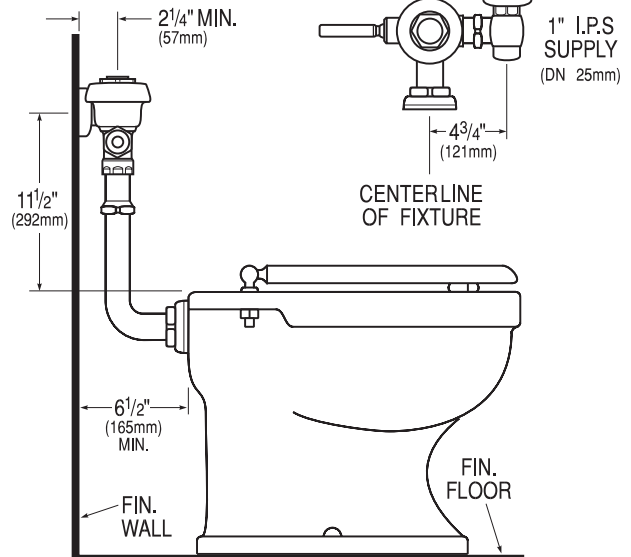

### !!! IMPORTANT !!!

Protect the chrome or special finish of Sloan Flushometers – **DO NOT USE** toothed tools to install or service these valves. Use a Sloan A-50 Super-Wrench™, Sloan A-109 Plier Wrench or smooth jawed spud wrench to secure all couplings. Also see "Care and Cleaning" section of this manual.

### !!! IMPORTANT !!!

This product contains mechanical and/or electrical components that are subject to normal wear. These components should be checked on a regular basis and replaced as needed to maintain the valve's performance.

### !!! IMPORTANT !!!

When mounted on an ADA accessible bowl, the rough-in to the supply inlet should be no higher than 37½" or the handle will exceed maximum height allowances under ADA guidelines.

New ADAAG Guidelines allow for Split or Offset Grab Bars, check with local authorities or reference section 604.5.2 of ADAAG.

# 1 - INSTALL OPTIONAL SWEAT SOLDER ADAPTER (ONLY IF YOUR SUPPLY PIPE DOES NOT HAVE MALE THREAD)

**A** Measure from finished wall to C/L of fixture spud. Cut pipe 1" (32 mm) shorter than this measurement. Chamfer O.D. and I.D. of water supply pipe.

**B** Slide threaded adapter fully onto pipe.

**C** Sweat solder the adapter to pipe.

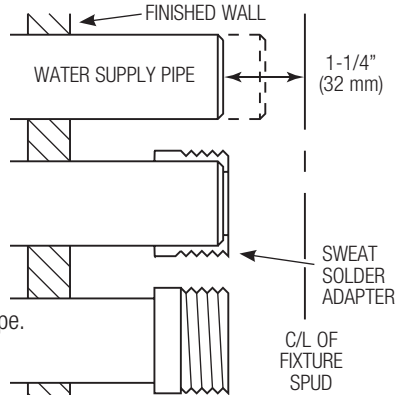

**!!! IMPORTANT !!!**  
**WITH THE EXCEPTION OF THE CONTROL STOP INLET, DO NOT USE PIPE SEALANT OR PLUMBING GREASE ON ANY VALVE COMPONENT OR COUPLING!**

**A** Measure from finished wall to first thread of adapter or threaded supply pipe (dimension "X"). Cut cover tube to this length.

**B** Slide cover tube over pipe. Slide wall flange over cover tube until against wall.

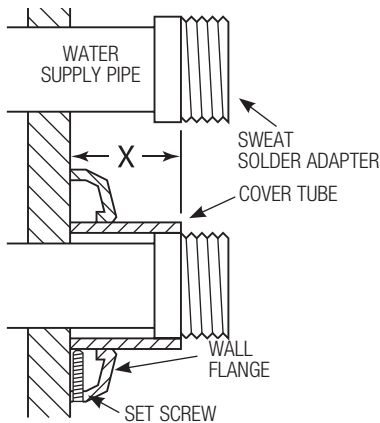

**C** Thread Control Stop onto pipe. Tighten with a wrench.

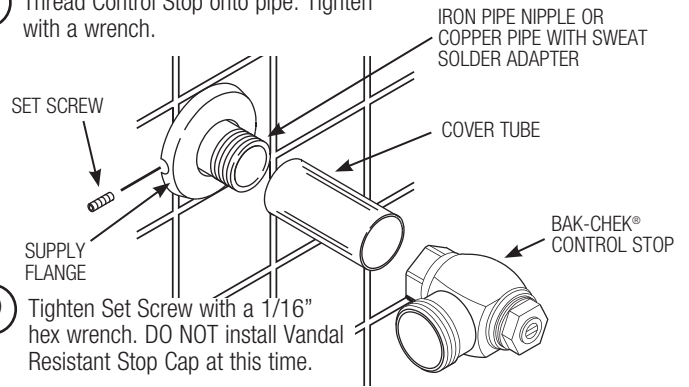

**D** Tighten Set Screw with a 1/16" hex wrench. DO NOT install Vandal Resistant Stop Cap at this time.

# 3 - INSTALL VACUUM BREAKER CONNECTION

**A** Slide spud coupling, nylon slip gasket, rubber gasket and spud flange over vacuum breaker tube.

**B** Insert tube into fixture spud.

**C** Hand tighten spud coupling onto fixture spud.

**NOTE**

Follow instructions on bag of high back pressure vacuum breaker kit included with flushometer: insert baffle into groove of vacuum breaker sack; insert sack in vacuum breaker tube; and place friction ring on top of sack.

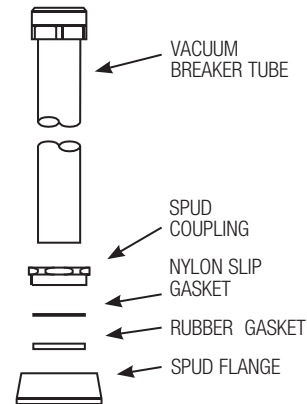

# 4 - INSTALL FLUSHOMETER

**A** Lubricate tailpiece o-ring with water. Insert adjustable tailpiece into control stop. Tighten tailpiece coupling by hand.

**B** Align flushometer directly above the vacuum breaker flush connection by sliding the flushometer body IN or OUT as needed. Tighten vacuum breaker coupling by hand.

**C** Align flushometer body and securely tighten first the tailpiece coupling (1), then the vacuum breaker coupling (2), and finally the spud coupling (3). Use a wrench to tighten these couplings in the order shown.

**NOTE**

**MAXIMUM** adjustment of Sloan adjustable tailpiece is 1/2" (13 mm) IN or OUT from the standard 4 3/4" (121 mm) (centerline of flushometer to centerline of control stop).

If roughing-in measurement exceeds 5 1/4" (133 mm), a longer tail may be supplied.

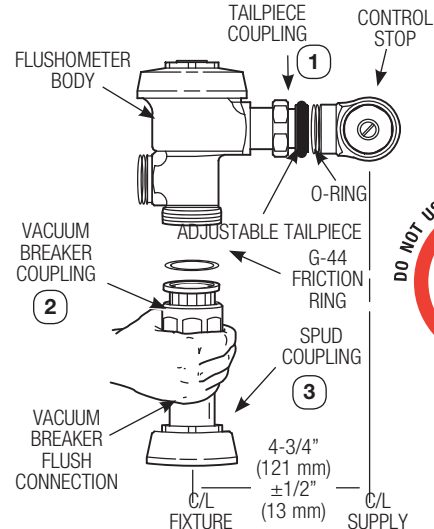

## 5 - INSTALL DUAL-FLUSH HANDLE ASSEMBLY AND GASKET (IF NOT ALREADY INSTALLED)

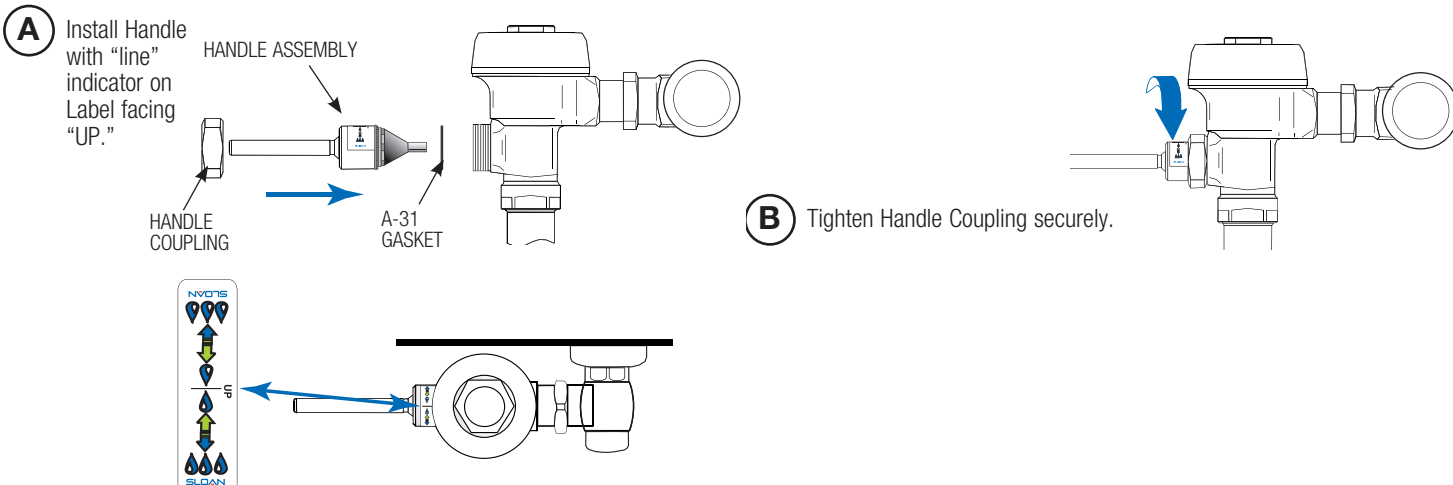

## 6 - FLUSH OUT SUPPLY LINE

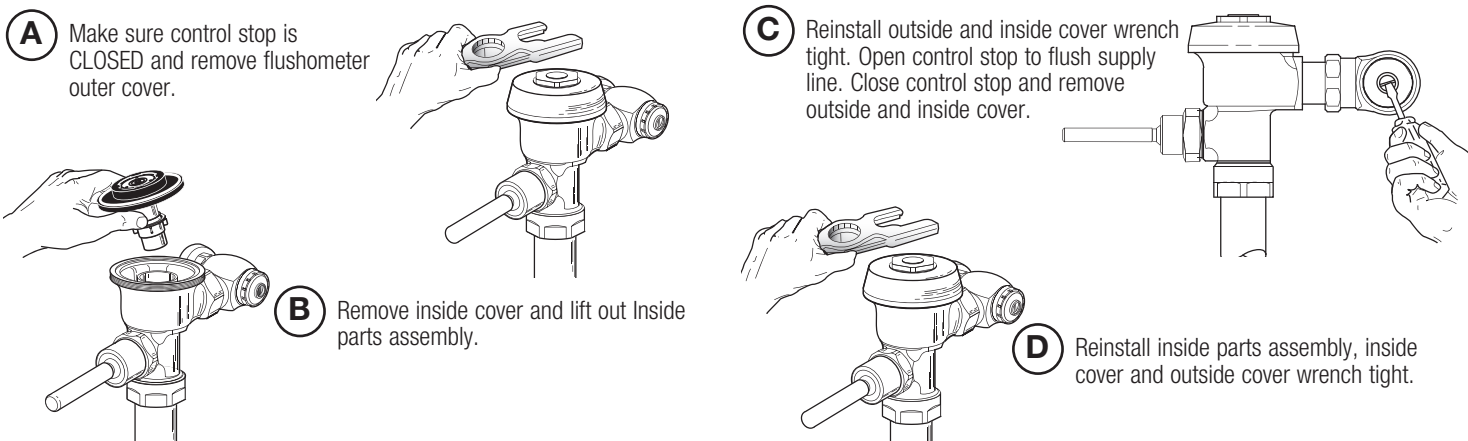

## 7 - ADJUST CONTROL STOP AND INSTALL VANDAL RESISTANT STOP CAP

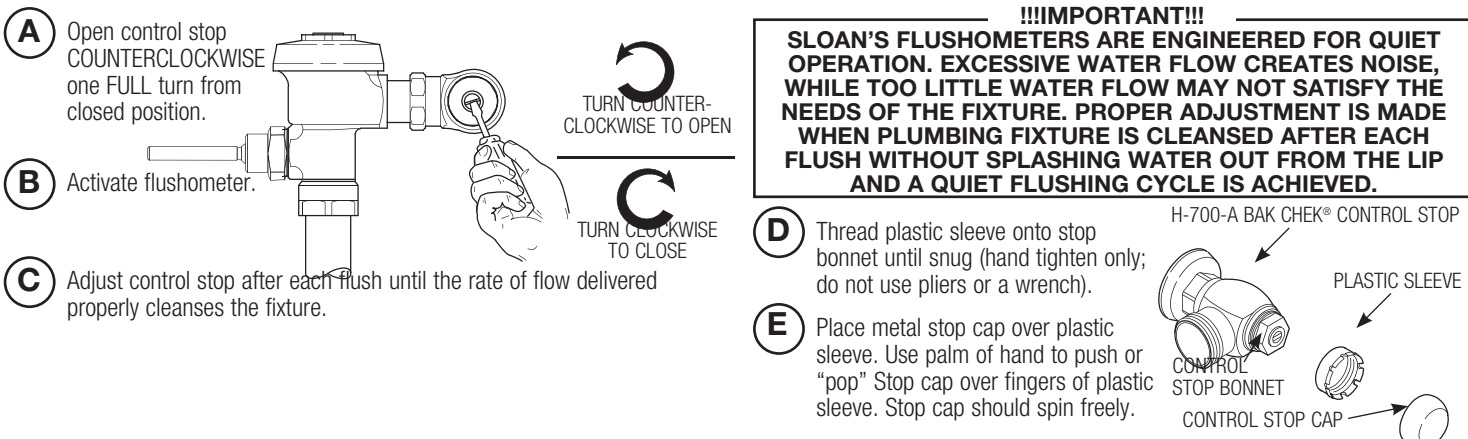

## 8 - INSTALL DUAL-FLUSH INSTRUCTION PLATES (RECOMMENDED PLATE LOCATIONS)

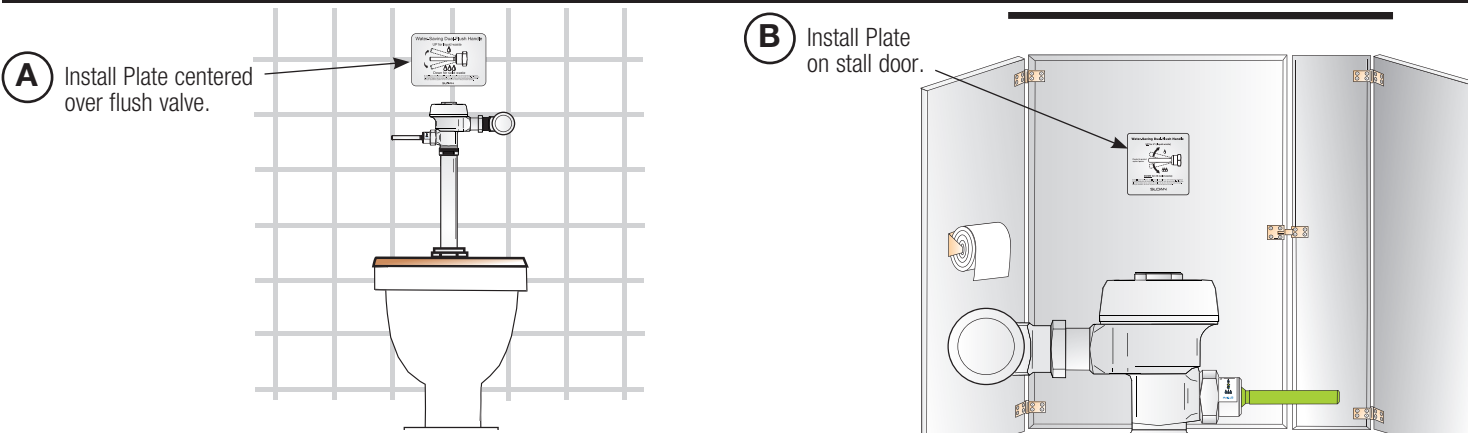

## VANDAL RESISTANT CONTROL STOP CAP REMOVAL

Use a large flat screwdriver as a lever to remove the cap from the control stop. Insert the screwdriver blade between the bottom edge of the cap and the flat surface of the control stop body as shown. Push the screwdriver handle straight back toward the wall to gently lift the cap. If necessary, work the screwdriver around the diameter of the cap until you can grasp the cap and lift it completely off the sleeve. The sleeve should remain attached to the bonnet of the control stop.

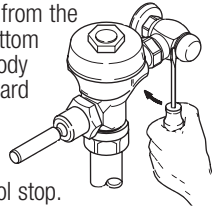

## TROUBLESHOOTING GUIDE

### 1. Flushometer does not function (no flush).

- Control stop or main valve is closed. Open control stop or main valve.
- Handle assembly is damaged. Replace handle (WES-212).
- Relief valve is damaged. Replace performance kit.

### 2. Volume of water is not sufficient to siphon fixture.

- Control stop is not open wide enough. Adjust control stop for desired delivery of water volume.
- Dual-filtered diaphragm assembly is damaged. Replace performance kit.
- Incorrect dual-filtered diaphragm assembly is installed in flushometer; for instance, urinal assembly inside a closet flushometer, or low consumption assembly inside a higher consumption fixture. Determine the flush volume required by the fixture and replace performance kit. Use valve label and markings on fixture for reference.
- Water supply volume or pressure is inadequate. If no gauges are available to properly measure supply pressure or volume of water at the flushometer, then remove the relief valve from the dual-filtered diaphragm assembly, reassemble the flushometer and completely open the control stop.
  - If the fixture siphons, more water volume is required. Install a higher flushing volume performance kit. **IMPORTANT — LAWS AND REGULATIONS PROHIBIT THE USE OF HIGHER FLUSHING VOLUMES THAN LISTED ON FIXTURE OR FLUSHOMETER.**
  - If the fixture does not siphon or if a low consumption flush is required, steps must be taken to increase the water supply pressure and/or volume. Contact the fixture manufacturer for minimum water supply requirements of the fixture.

### 3. Length of flush is too short (short flush).

- Dual-filtered diaphragm assembly is damaged. Replace performance kit.
- Handle assembly is damaged. Replace handle (WES-212).

## CARE AND CLEANING

DO NOT use abrasive or chemical cleaners (including chlorine bleach) to clean flushometers that may dull the luster and attack the chrome or special decorative finishes. Use ONLY mild soap and water, then wipe dry with clean cloth or towel.

While cleaning the bathroom tile, protect the flushometer from any splattering of cleaner. Acids and cleaning fluids will discolor or remove chrome plating.

- Incorrect dual-filtered diaphragm assembly is installed in flushometer; for instance, urinal assembly inside a closet flushometer, or low consumption assembly inside a higher consumption fixture. Determine the flush volume required by the fixture and replace performance kit. Use valve label and markings on fixture for reference.

### 4. Length of flush is too long (long flush) or continuous.

- Metering bypass hole in diaphragm is clogged. Remove the dual-filtered diaphragm assembly. Remove the primary and secondary filter rings from the diaphragm and wash under running water. Replace performance kit if cleaning does not correct the problem.
- Diaphragm or relief valve is damaged. Replace performance kit.
- Incorrect dual-filtered diaphragm assembly is installed in flushometer; for instance, closet assembly inside a urinal flushometer, or water saver assembly inside a low consumption flushometer. Determine the flush volume required by the fixture and replace the performance kit. Use valve label and markings on fixture for reference.
- Inside cover is damaged. Replace inside cover (A-71).
- Supply line water pressure has dropped and is not sufficient to close the valve. Close control stop until pressure is restored.

### 5. Chattering noise is heard during flush.

- Inside cover is damaged. Replace inside cover (A-71).

### 6. Handle Leaks.

- Handle seal or assembly is damaged. Replace handle (WES-212).

If assistance is required, please contact Sloan Technical Support at:

**1-888-SLOAN-14 (1-888-756-2614)**

or visit us online at: [www.sloanvalve.com](http://www.sloanvalve.com)

## PARTS LIST

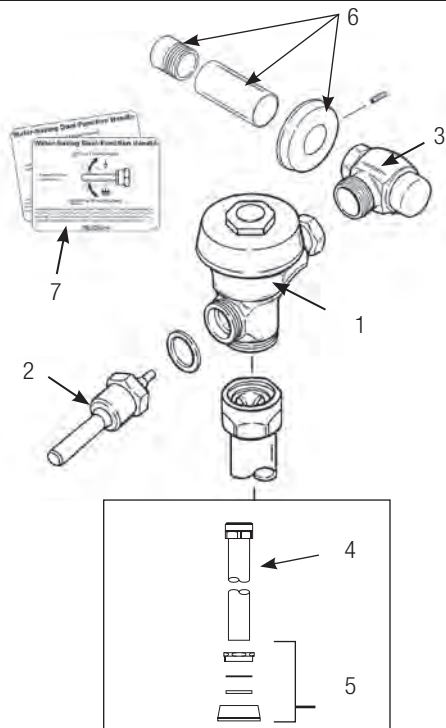

Item No.	Part No.	Description
1	†	Valve Assembly
2	WES-212	ADA Compliant Dual-Flush Handle Assembly
3	H-700-A	Bak-Chek® Control Stop
4	V-600-AA	1-1/2" (38 mm) x 9" (229 mm) Vacuum Breaker Assembly ‡
5	F-5-A	1-1/2" (38 mm) Spud Coupling Assembly
6	H-633-AA	1" (25 mm) Sweat Solder Kit with Cast Set Screw Flange
7	WES-13	Wall Plates (2) – English
	WES-18	Wall Plates (2) – Spanish
†		Part number varies with valve model variation; consult factory.
‡		Length varies with valve model variation; consult factory.

For optimum water conservation and flushometer performance, use only Genuine Sloan Parts.

Manufactured in the U.S.A. by Sloan Valve Company under one or more of the following patents: U.S. Pats. 5,295,655; 5,505,427; 5,542,718; 5,558,120; 5,564,460; 5,649,686; 5,730,415; 7,607,635. Other Pats. Pending. BAK-CHEK®, PARA-FLO®, PERMEX®, TURBO-FLO®. Additional patent(s) pending.

NOTE: The information contained in this document is subject to change without notice.

**SLOAN HEADQUARTERS • 10500 SEYMOUR AVENUE • FRANKLIN PARK, IL 60131**

Phone: 1-800-9-VALVE-9 • Fax: 1-800-447-8329 or 1-847-671-4380 • [www.sloanvalve.com](http://www.sloanvalve.com)