

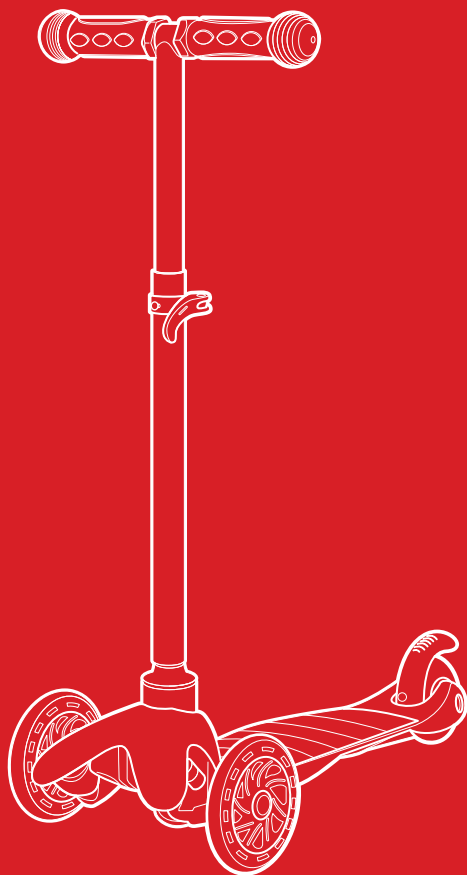

bestchoiceproducts



# INSTRUCTION MANUAL

---

Kids Mini Kick Scooter



bestchoiceproducts

---

As shoppers, we're always trying to find the perfect balance between quality & value. At BCP, we believe we've achieved that. Our diverse catalog of everyday essentials is tailored especially to our customers & guaranteed to hit that sweet spot of high quality & low price.

— Always. —

## NOTICE

Please retain these instructions for future reference.

- Only one child may ride the scooter at a time.
- Do not exceed 3 miles per hour.
- Please do not exceed the weight limitations of this item.
- Firmly secure all bolts, screws, and knobs before use.
- Reconfirm that all bolts, screws, and knobs are secure every 90 days.
- If any parts are missing, broken, damaged, or worn, stop using this item until repairs are made and/or factory replacement parts are installed.
- Do not use this item in a way inconsistent with the manufacturer's instructions as this could void the product warranty.

**WEIGHT CAPACITY:** 88 lbs.

**AGE RANGE:** 3 years old and up

**RECOMMENDED MAX SPEED:** 3 miles/hour

## WARNING

- Children should learn how to control a scooter before riding.
- Be aware that riding a scooter is dangerous and can lead to accidents.
- Do not ride scooter in traffic.
- Do not ride scooter downhill on slopes as the brake does not effectively stop at high speeds.
- Do not brake for an extended period of time.
- Brake will get hot during use. Do not touch brake directly after use.
- Do not ride scooter on roads, highways, or any place where motor vehicles drive.
- Do not ride in dark conditions, such as dusk or night.
- Do not attempt dangerous stunts on the scooter.
- Be aware that loosening/tightening the axle or screws too often can affect the fastening of the screws and result in screws loosening more easily.

## SCOOTER WARNING

- Always wear safety equipment such as helmet, knee pads and elbow pads. Always wear a helmet when riding your scooter and keep the chinstrap securely buckled. Always wear shoes.
- Avoid sharp bumps, drainage grates, and sudden surface changes. Scooter may suddenly stop.
- Avoid streets and surfaces with water, sand, gravel, dirt, leaves, and other debris. Wet weather impairs traction, braking, and visibility.
- Avoid excessive speed associated with downhill rides.
- Adults must assist children in the initial adjustment procedures to unfold scooter and adjust handlebar and steering to height.
- Watch out for pedestrians.
- Check and secure all fasteners before every ride.
- Replace worn or broken parts immediately.

## MAIN DIAGRAM

- **HEIGHT ADJUSTMENT BUTTON:** Compress button to adjust handlebar height

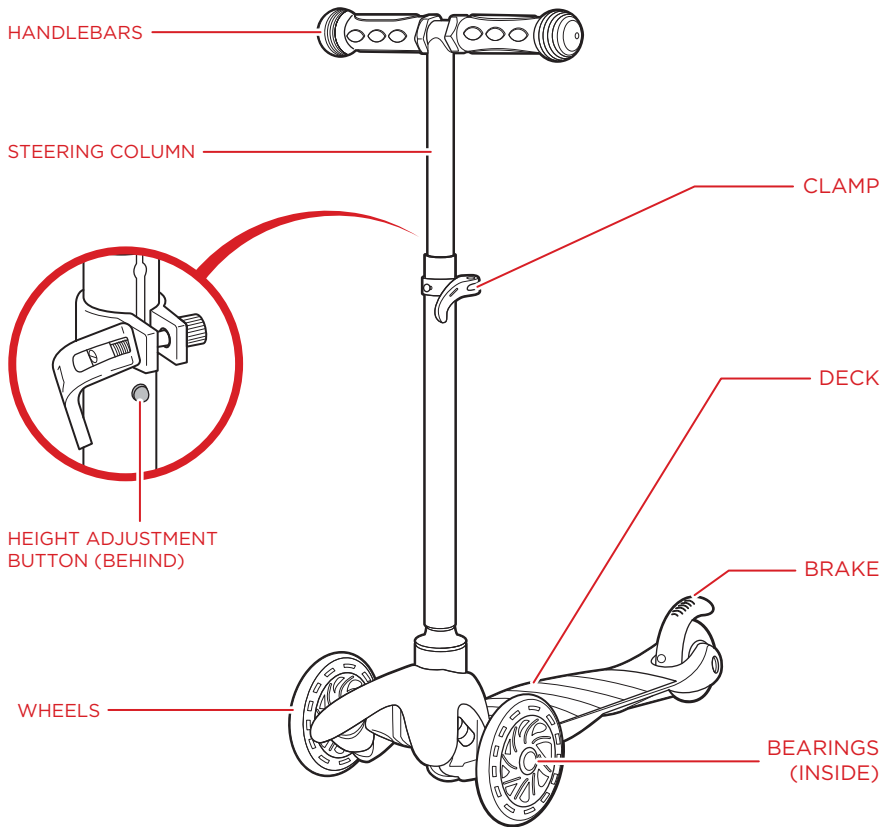

## PARTS

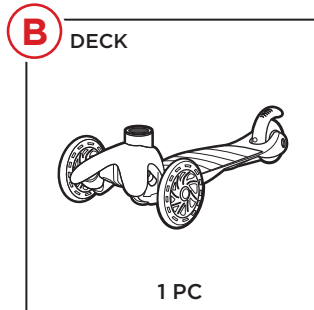
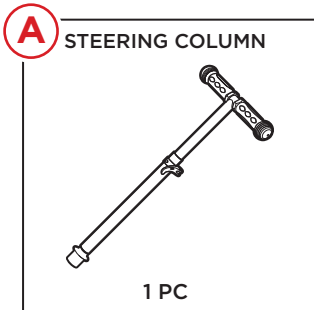

## PRODUCT ASSEMBLY

1

Insert the part A steering column into the part B deck until it locks in place.

**NOTE:** When inserting, compress the tab and align it with the designated slot.

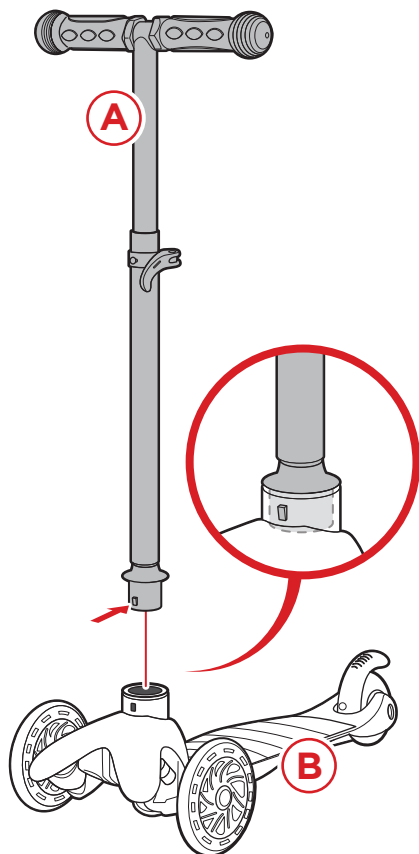

2

Release the clamp. Compress the button and slide the steering column up/down to adjust the handlebar height. Lock the clamp at your desired height.

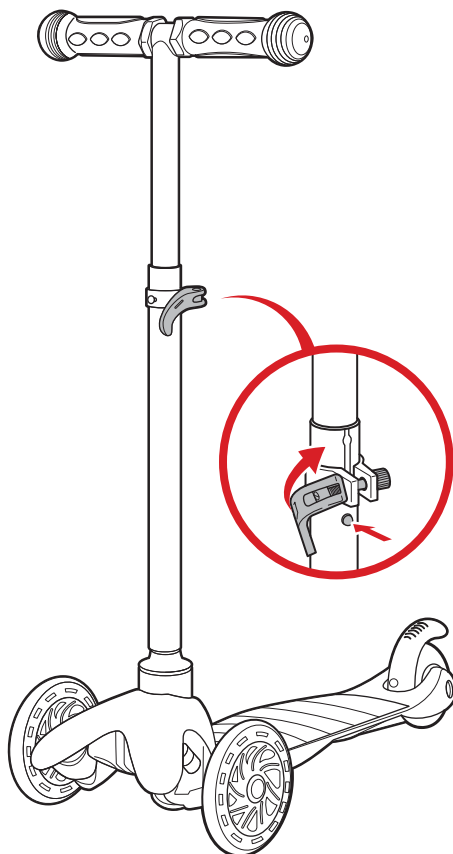

**NOTE:** Before use, ensure that all screws, steering column, and wheels are fastened tightly and do not have excessive wear.

## OPERATING INSTRUCTIONS

1. Step on the deck with one foot and use the other foot to propel the scooter forward.

**NOTE:** Typically, if right-handed, step left foot on deck; vice versa if left-handed.

2. To stop the scooter, apply the brake by stepping down on the rear brake with the heel of your shoe.

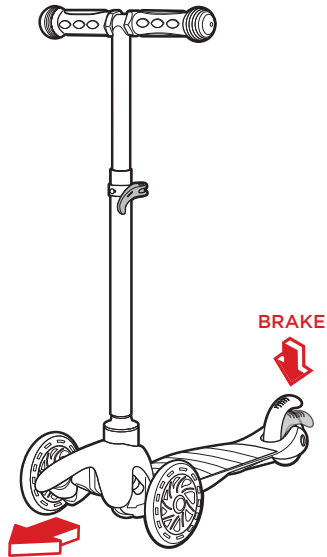

## CARE AND STORAGE

- If necessary, clean scooter with a damp cloth.
- If wheels are not turning smoothly, lubricate the bearings.
- Do not change a single wheel or bearing as this may result in instability when riding.
- Store in a cool, dry place away from direct sunlight.

## SPECIFICATIONS

Wheel Diameter	120mm
Wheel Width	24mm
Bearings	ABEC-5

Earn points while you shop. Join today!

bestchoiceproducts  
**rewards**

Join | Earn | Redeem

Give your friends 15% off their first order! For each successful referral you'll receive 100 points.

[bestchoiceproducts.com](https://bestchoiceproducts.com)



# HELP CENTER



Question about your product? We're here to help. Visit us at:

[help.bestchoiceproducts.com](http://help.bestchoiceproducts.com)



Chat Support



Product Inquiry



Orders FAQ



Product Assembly



Returns & Refunds

## PRODUCT WARRANTY INFORMATION

All items can be returned for any reason within 60 days of the receipt and will receive a full refund as long as the item is returned in its original product packaging and all accessories from its original shipment are included. All returned items will receive a full refund back to the original payment method. All returned items will not be charged a re-stocking fee.

All returned items require an RA (Return Authorization) number, which can only be provided by a Best Choice Products Customer Service Representative when the return request is submitted. Items received without an RA may not be accepted or may increase your return processing time. Once an item has been received by Best Choice Products, refunds or replacements will be processed within 5 business days.

All returns must be shipped back to the Best Choice Products Return Center at the customer's expense. If the reason for return is a result of an error by Best Choice Products then Best Choice Products will provide a pre-paid shipping label via email. Boxes for return shipping will not be provided by Best Choice Products, and is the customer's responsibility to either use the original shipping boxes or purchase new boxes.

Pictures may be required for some returns to ensure an item is not damaged prior to its return. Items returned are not considered undamaged until they are received by Best Choice Products and verified as such. All damages to items are the customer's responsibility until the item has been received by and acknowledge by Best Choice Products as undamaged.



## WARNING

Manufacturer and seller expressly disclaim any and all liability for personal injury, property damage or loss, whether direct, indirect, or incidental, resulting from the incorrect attachment, improper use, inadequate maintenance, or neglect of this product.