





HEKMAN®

A HOWARD MILLER COMPANY

ASSEMBLY INSTRUCTION FOR 24504 END TABLE

HARDWARE LIST

NO.	ITEM	DESCRIPTIN	QTY.
1		JCB Bolt M6 X 13 MM	8
2		Allen wrench	1
3		Bolt M8X20 MM	4
4		Flat washer M6X25 MM	4
5		Wrench	1

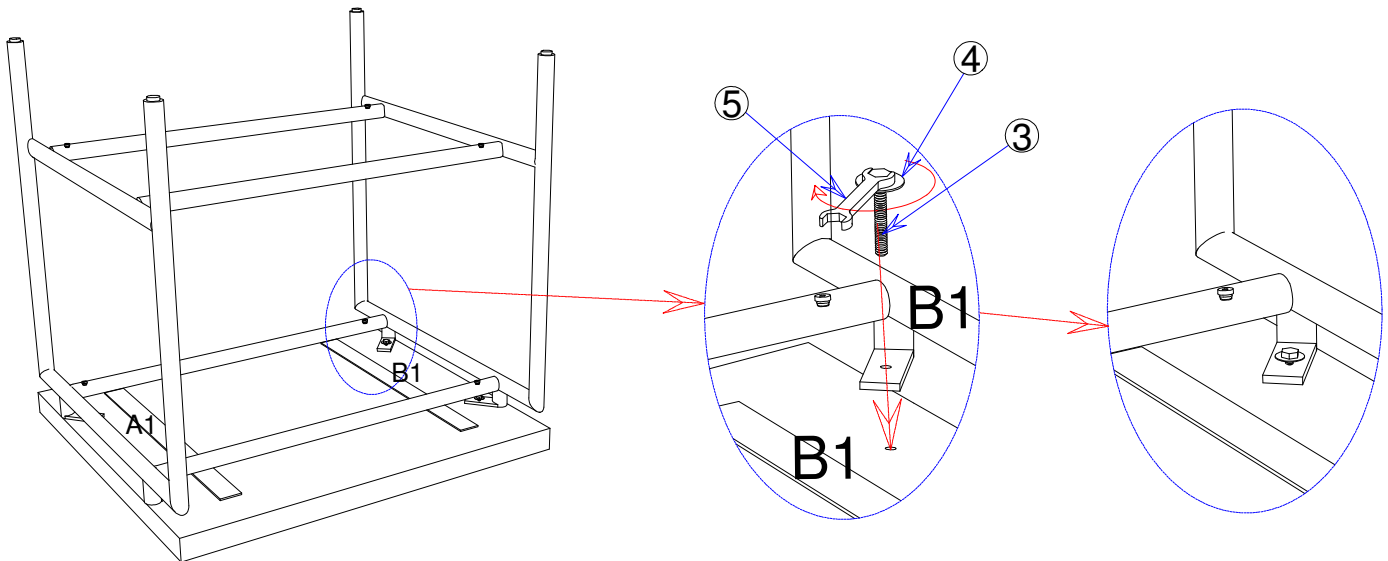
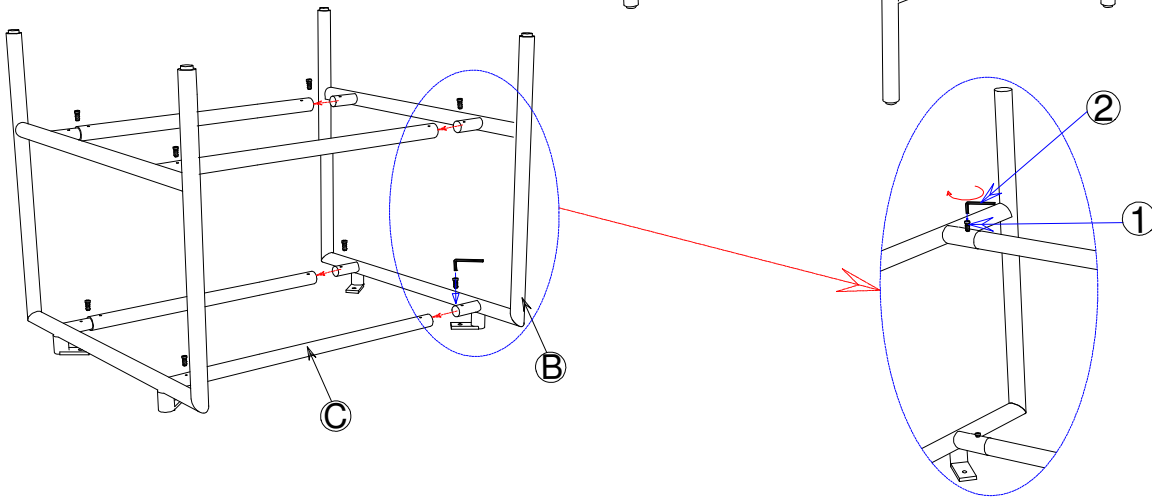
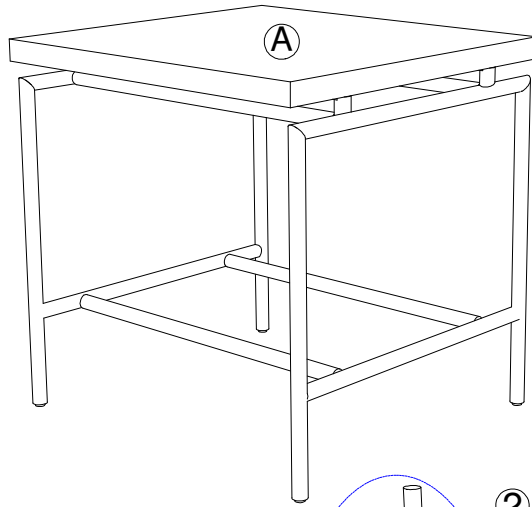

TO ASSEMBLY :

STEP 1 : Unpack end table.

STEP 2 : Roll end table on its back, then on its top on a clean, soft surface.

STEP 3 : Thread the JCB bolt (1) to iron leg(B) & iron cross bar(C).using tighten end assemblies fully.

STEP 4 : Set base assembly on the upside down case and attach HEX bolt (3) and washer (4) using allen wrench (5).

STEP 5 : Tighten bolts in step 4 fully with wrench (5) then carefully turn the end table upright.