



bestchoiceproducts



INSTRUCTION MANUAL

Folding Sewing Craft Table

SKY5834 + SKY6212 + SKY6281 + SKY7530 + SKY7531 + SKY7532
SKY7533

! NOTICE

Please retain these instructions for future reference.

- Please do not exceed the weight limitations of this item.
- Do not stand on or use any part of this item as a step ladder.
- Firmly secure all bolts, screws, and knobs before use.
- Reconfirm that all bolts, screws, and knobs are secure every 90 days.
- Do not use or store this item in the proximity of open flame or flammable/combustible chemicals.
- If any parts are missing, broken, damaged, or worn, stop using this item until repairs are made and/or factory replacement parts are installed.
- Do not use this item in a way inconsistent with the manufacturer's instructions as this could void the product warranty.
- This product is intended for residential use only.

TOOLS REQUIRED



PHILLIPS
SCREWDRIVER



FLAT HEAD
SCREWDRIVER



5 LBS
EXTENSION
CAPACITY



40 LBS
TOTAL
CAPACITY



1 PERSON
ASSEMBLY



UP TO 60 MIN.
ASSEMBLY

HARDWARE

A CAM BOLT



14 PCS

B CAM LOCK



14 PCS

C DOWEL



21 PCS

D M4 X 22MM
SCREW



18 PCS

E ANCHOR
SCREW SET



5 SETS

F M3 X 12MM
SCREW



9 PCS

G M3 X 16MM
SCREW



2 PCS

H M4 X 18MM
SCREW



1 PC

I KNOB



1 PC

J METAL PLATE



1 PC

K MAGNETIC
CATCH



1 PC

L HINGE

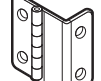

2 PCS

M LOCKING
CASTER



2 PCS

N CASTER



3 PCS

PARTS

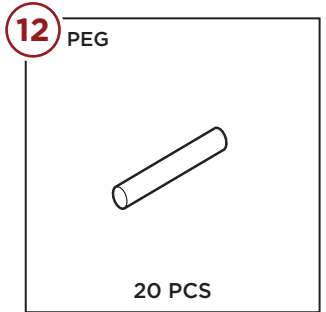
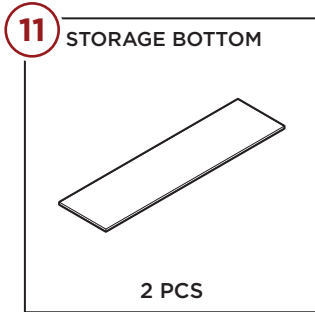
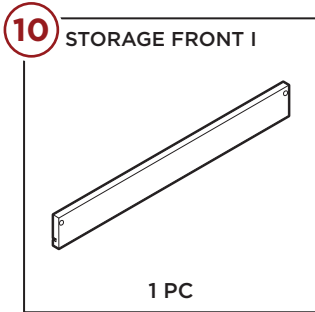
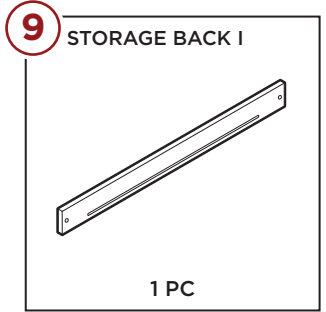
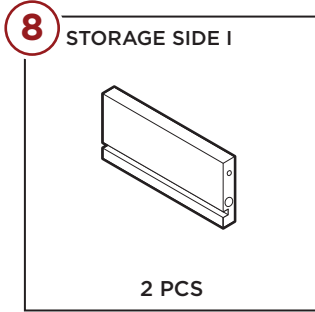
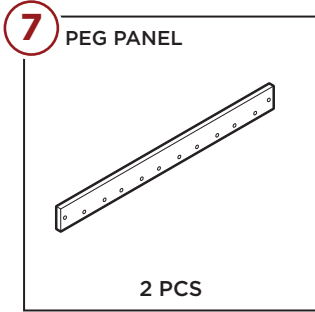
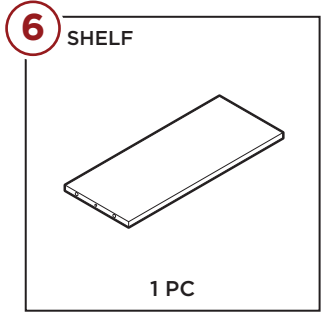
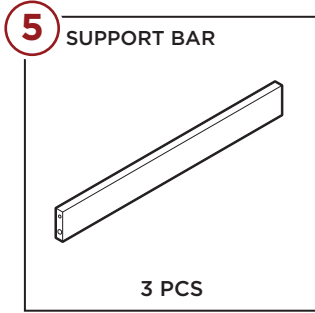
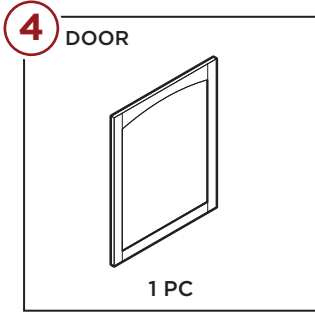
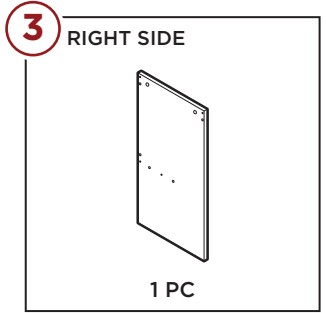
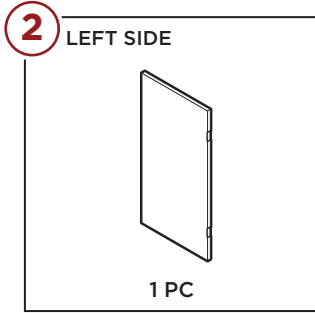
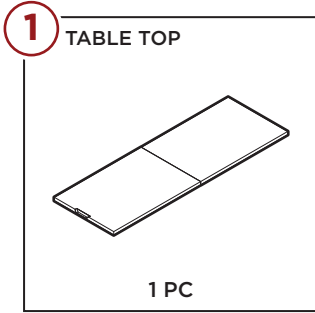

PARTS

13 STORAGE SIDE II

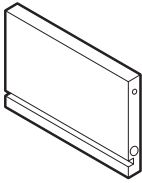

2 PCS

14 STORAGE BACK II

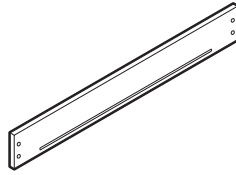

1 PC

15 STORAGE FRONT II

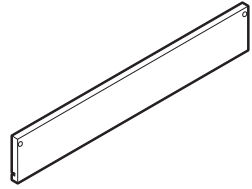

1 PC

TIGHTENING CAMLOCKS

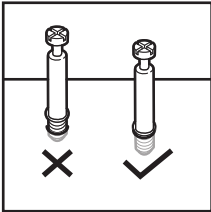

1. Screw cam bolt in completely.

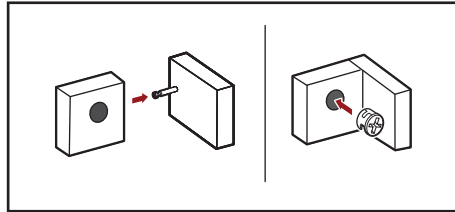

2. Insert cam bolt and cam lock into designated holes.

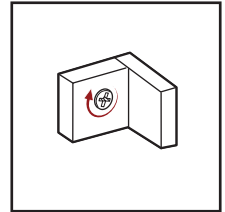

3. Screw cam lock clockwise to secure cam bolt.

PRODUCT ASSEMBLY

1

Attach a **part M locking caster** and **part N** caster to **part 2 left side** with two **part E anchor screw sets**.

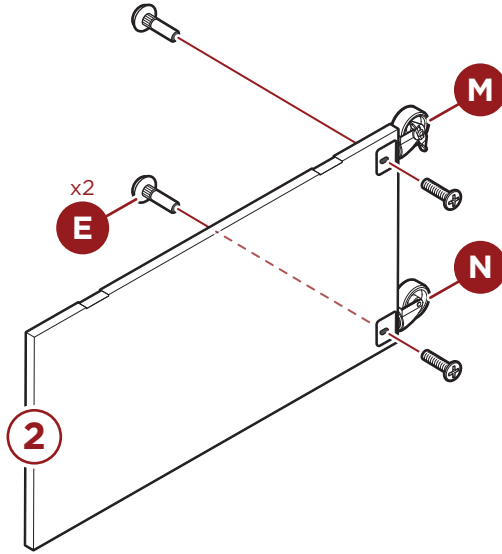

2

Screw five **part A cam bolts** into the left side.

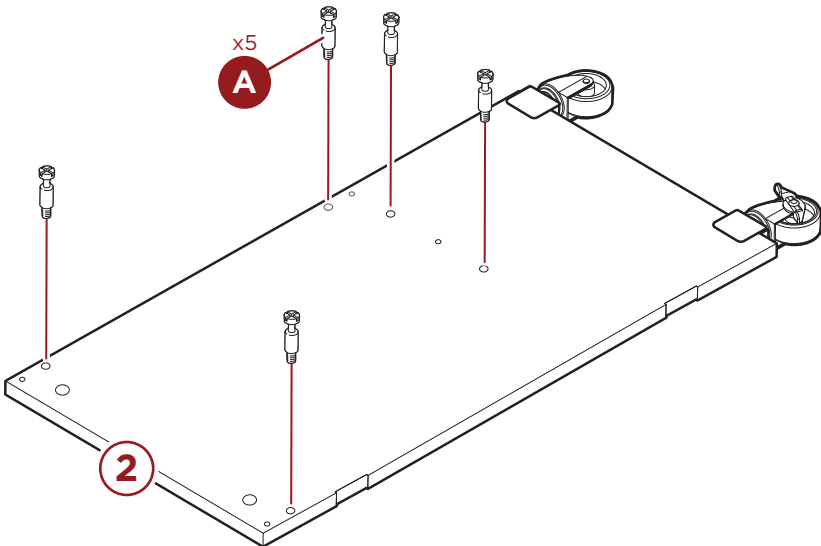

PRODUCT ASSEMBLY

3

Attach a **part M** locking caster and **part N** caster to **part 3** right side with two **part E** anchor screw sets.

Attach **part K** magnetic catch with two **part G** screws.

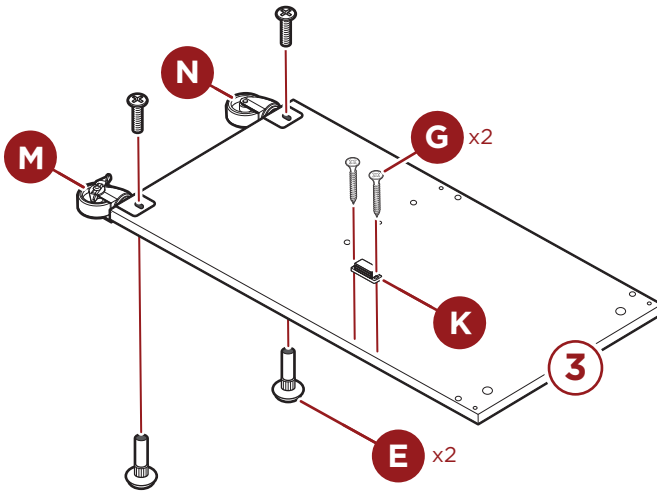

4

Screw five **part A** cam bolts into the right side.

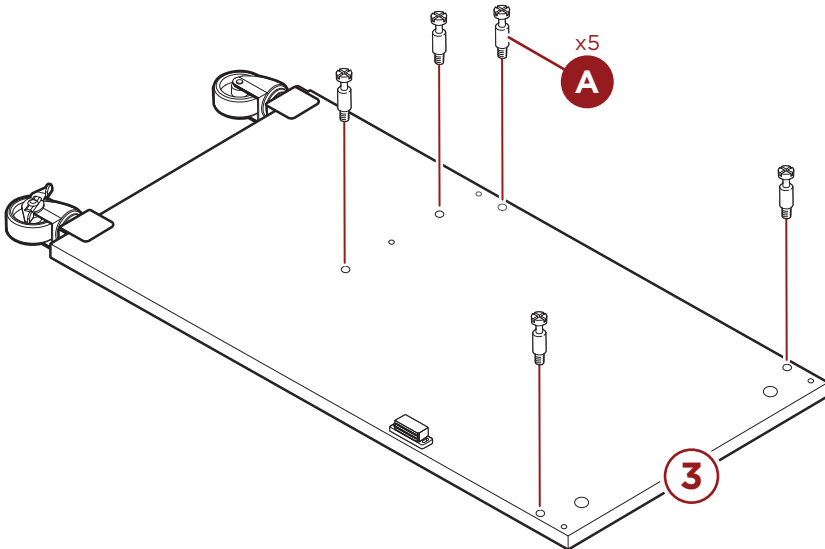

PRODUCT ASSEMBLY

5

Attach three **part 5 support bars** to the **part 3 right side** with three **part C dowels** and three **part B cam locks**.

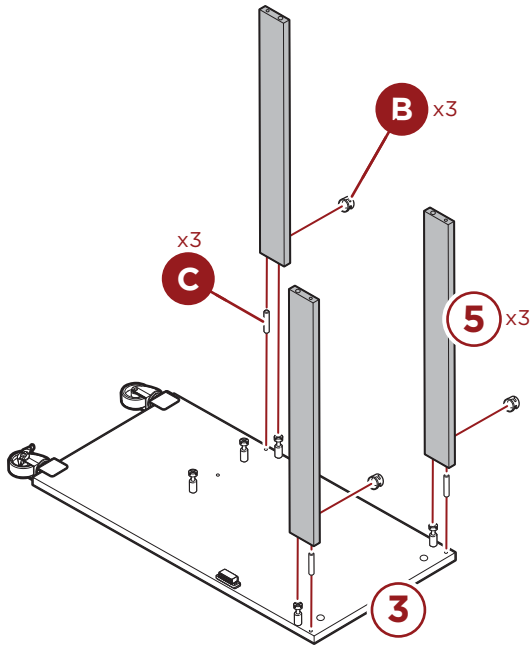

6

Attach **part 6 shelf** with a **part C dowel** and two **part B cam locks**.

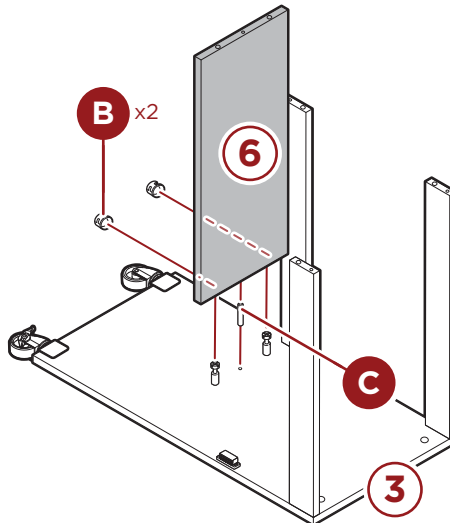

PRODUCT ASSEMBLY

7

Attach the **part 2 left side** with four **part C** dowels and five **part B** cam locks.

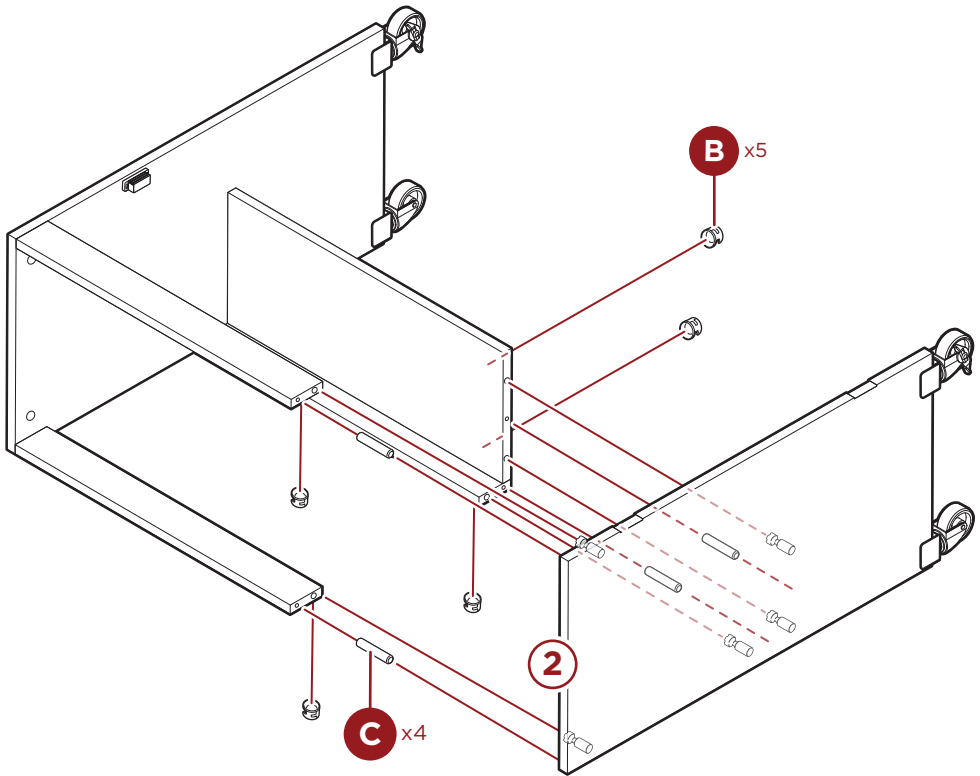

PRODUCT ASSEMBLY

8

Screw four **part A** cam bolts into the **part 1** tabletop.

Attach the tabletop with four **part C** dowels and four **part B** cam locks.

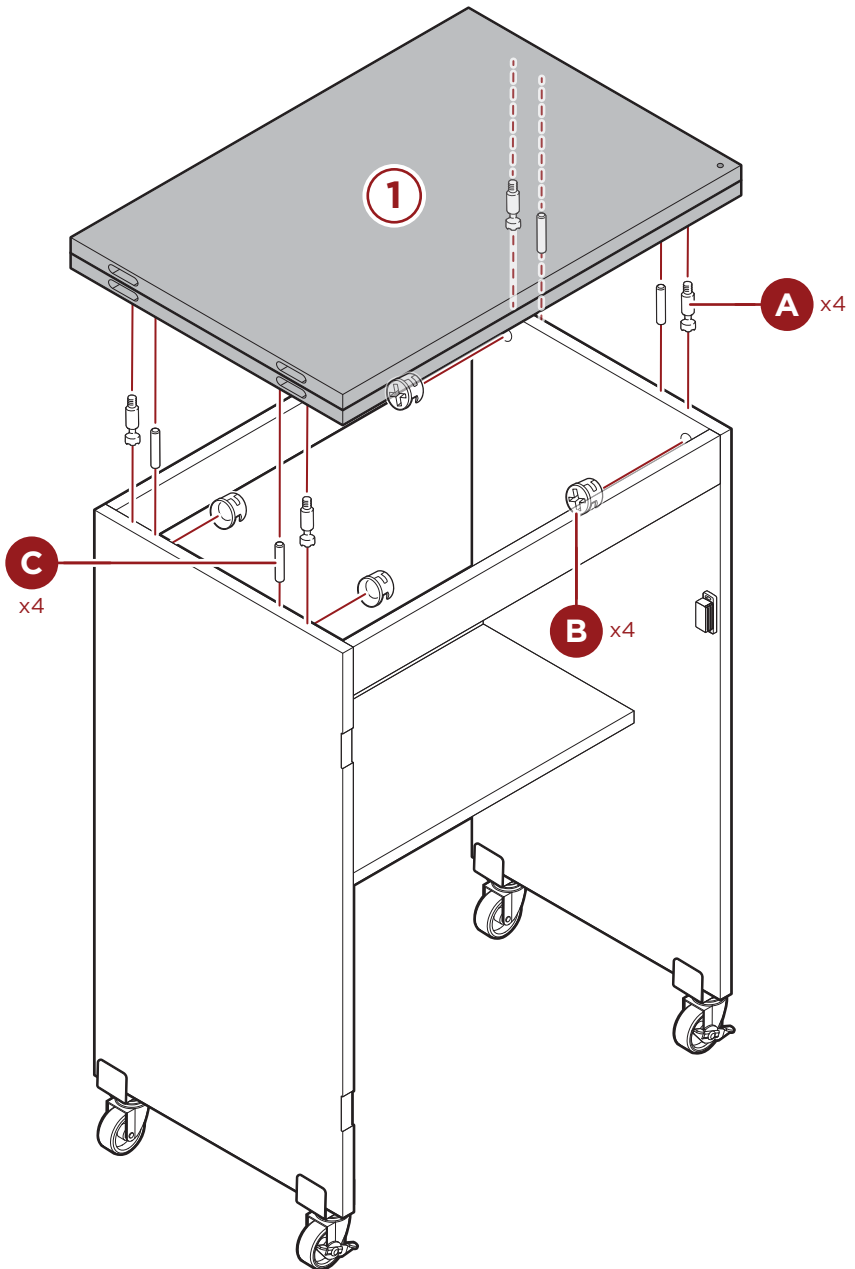

PRODUCT ASSEMBLY

9

Attach two **part 8 storage sides** to **part 9 storage back** with two **part C dowels** and two **D screws**.

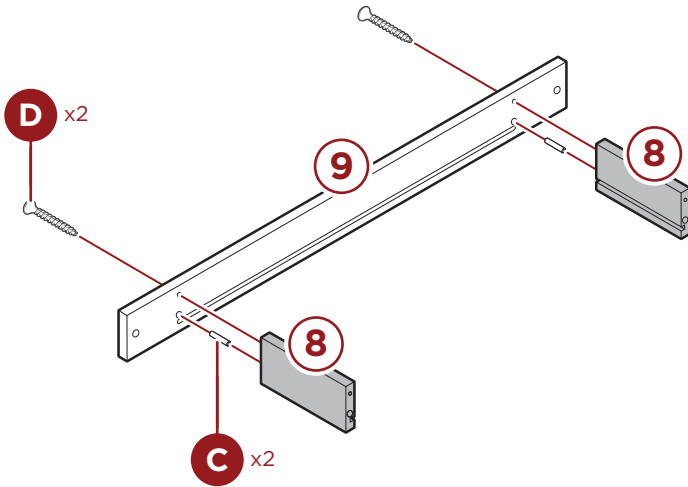

10

Slide in **part 11 storage bottom**.

Attach **part 10 storage front** with two **part C dowels** and two **part D screws**.

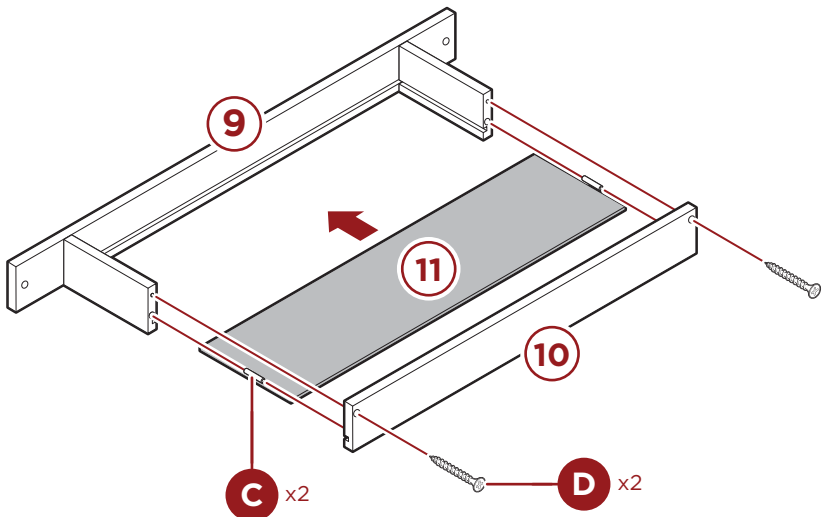

PRODUCT ASSEMBLY

11

Attach two **part 13 storage sides** to **part 14 storage back** with two **part C dowels** and two **D screws**.

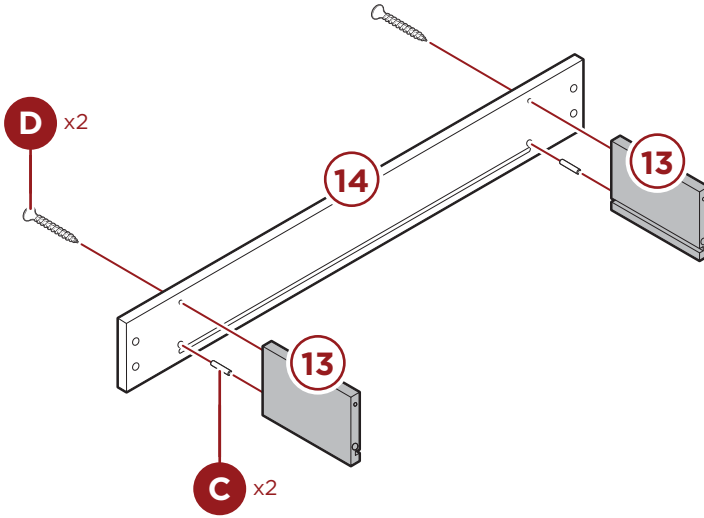

12

Slide in **part 11 storage bottom**.

Attach **part 15 storage front** with two **part C dowels** and two **part D screws**.

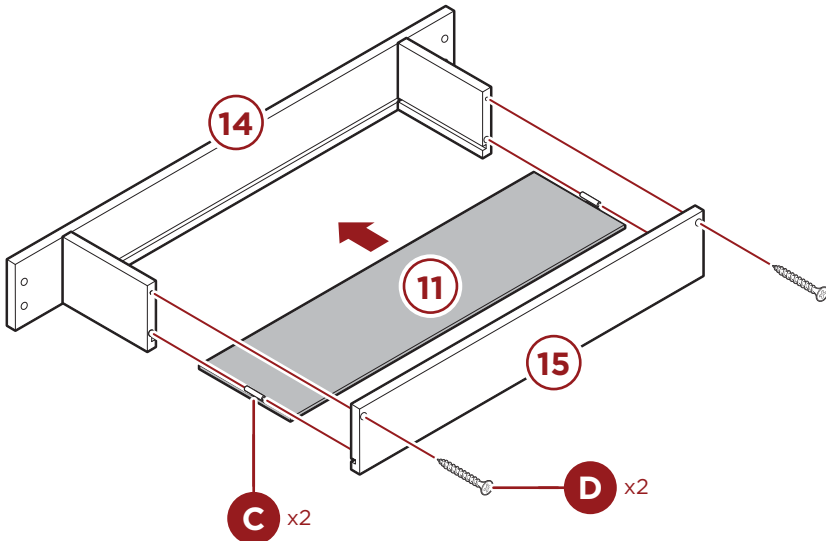

PRODUCT ASSEMBLY

13

- Attach a **part N** caster to the **part 4** door with one **part E** screw set.
- Attach **part I** knob with a **part H** screw.
- Attach **part J** metal plate with a **part F** screw.

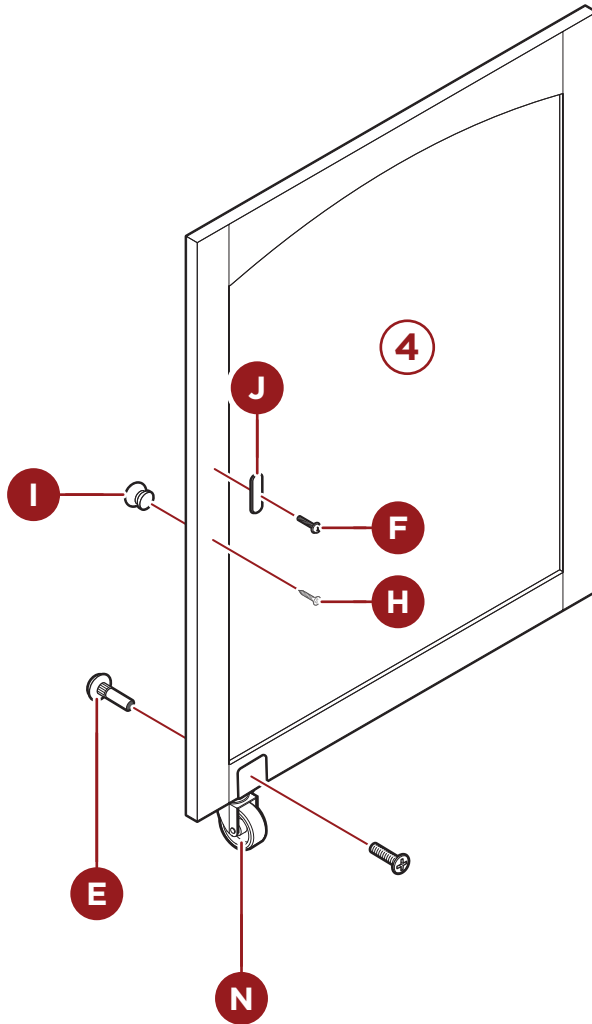

PRODUCT ASSEMBLY

14

Attach the two storage compartments and two **part 7** peg panels with ten **part D** screws.
Insert twenty **part 12** pegs into the peg panels.

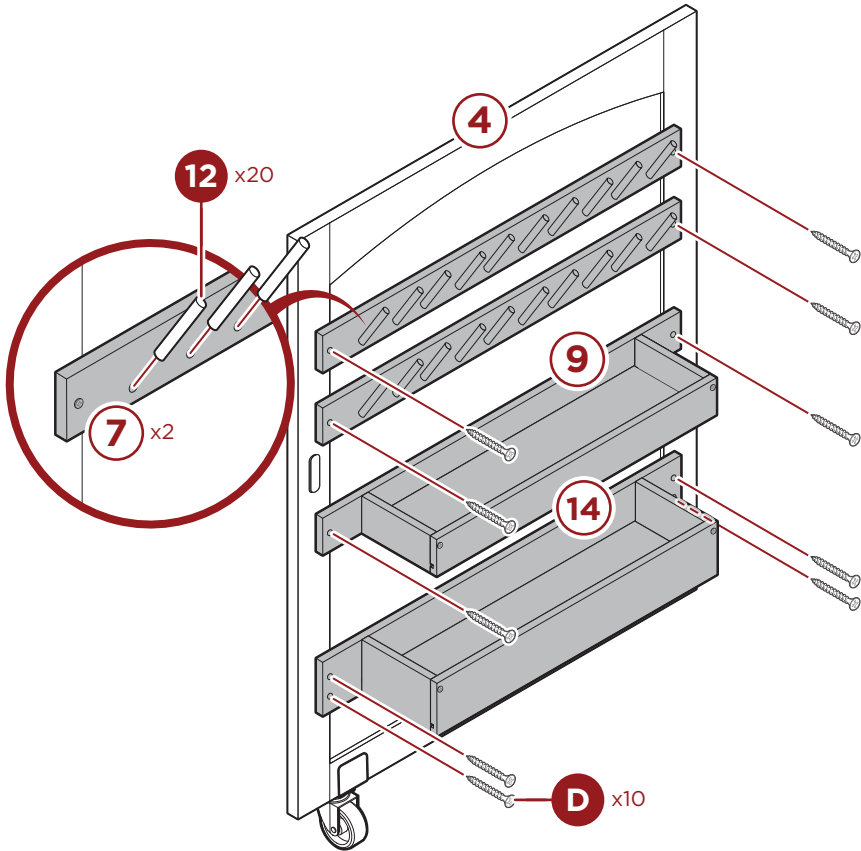

PRODUCT ASSEMBLY

15

Attach the door to the assembly with two **part L hinges** and eight **part F screws**.

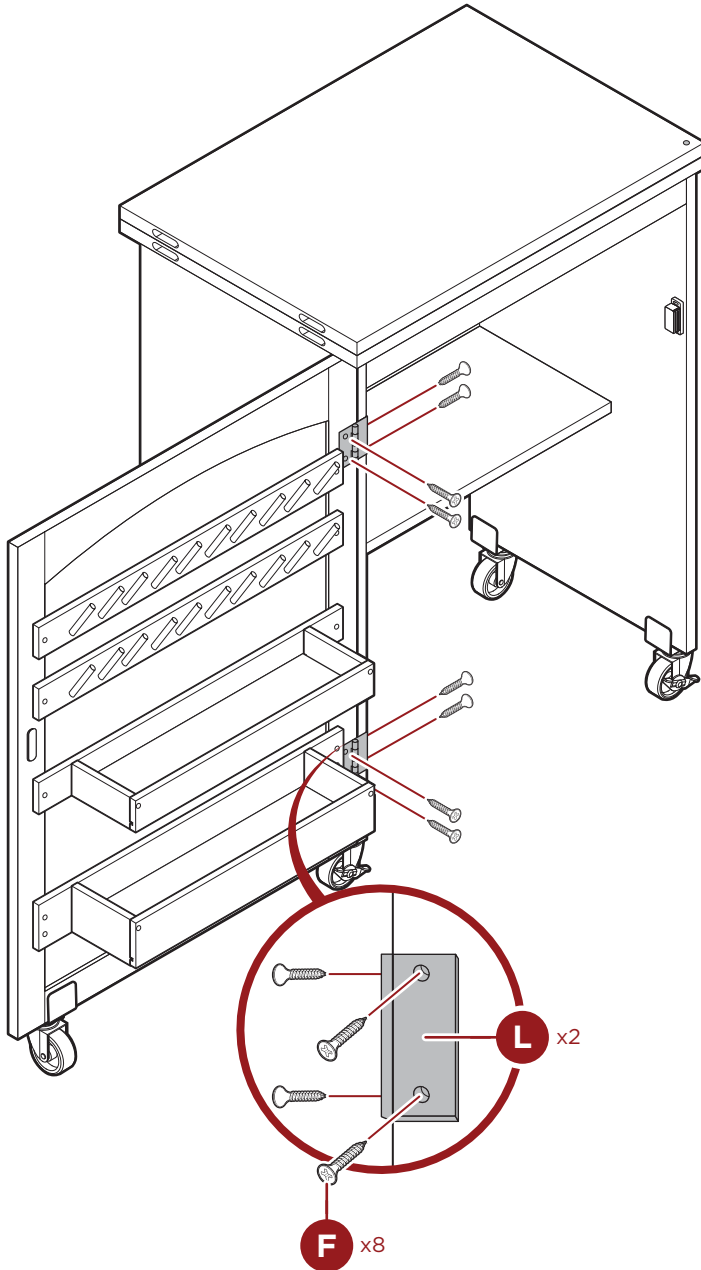

PRODUCT ASSEMBLY

16

Flip open the tabletop and secure it with a **part C** dowel.

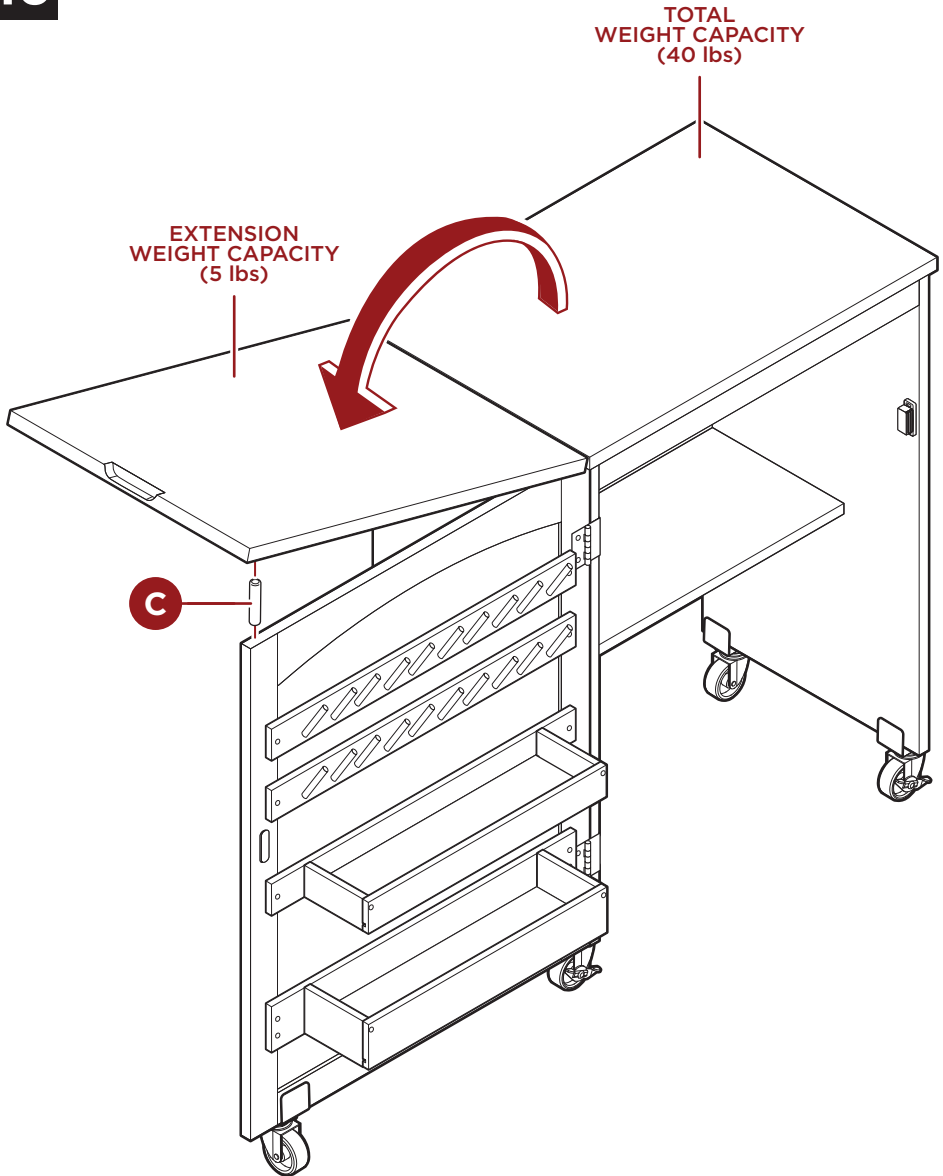



HELP CENTER



Question about your product? We're here to help. Visit us at:

help.bestchoiceproducts.com



Chat Support



Product Inquiry



Orders FAQ



Product Assembly



Returns & Refunds

PRODUCT WARRANTY INFORMATION

All items can be returned for any reason within 60 days of the receipt and will receive a full refund as long as the item is returned in its original product packaging and all accessories from its original shipment are included. All returned items will receive a full refund back to the original payment method. All returned items will not be charged a re-stocking fee.

All returned items require an RA (Return Authorization) number, which can only be provided by a Best Choice Products Customer Service Representative when the return request is submitted. Items received without an RA may not be accepted or may increase your return processing time. Once an item has been received by Best Choice Products, refunds or replacements will be processed within 5 business days.

All returns must be shipped back to the Best Choice Products Return Center at the customer's expense. If the reason for return is a result of an error by Best Choice Products then Best Choice Products will provide a pre-paid shipping label via email. Boxes for return shipping will not be provided by Best Choice Products, and is the customer's responsibility to either use the original shipping boxes or purchase new boxes.

Pictures may be required for some returns to ensure an item is not damaged prior to its return. Items returned are not considered undamaged until they are received by Best Choice Products and verified as such. All damages to items are the customer's responsibility until the item has been received by and acknowledged by Best Choice Products as undamaged.

© 2023 Best Choice Products, Inc. All rights reserved. Distributed by Best Choice Products, Inc. Tustin, CA 92780

WARNING

Manufacturer and seller expressly disclaim any and all liability for personal injury, property damage or loss, whether direct, indirect, or incidental, resulting from the incorrect attachment, improper use, inadequate maintenance, unapproved modification, or neglect of this product.