

TV stand

Meuble TV

Mueble para televisión



Get ready for assembly! Préparez-vous à l'assemblage!

Prepararse para el montaje!

You need assembly support or
replacement parts for your product?

Vous avez besoin de support à l'assemblage ou
de pièces de remplacement pour votre produit?

¿Necesita soporte de montaje o piezas
de repuesto para su producto?



Contact our customer
support heroes

Contactez nos héros au
service à la clientèle

Contacte a nuestros héroes
de servicio al cliente



Call us

Appelez-nous

llámenos

USA & Canada : 1-800-290-0465

Mexico : 001-800-514-5320

o al 800-522-6796



Send an Email at

Envoyez-nous un courriel au

Envianos un email al

service@southshorefurniture.com

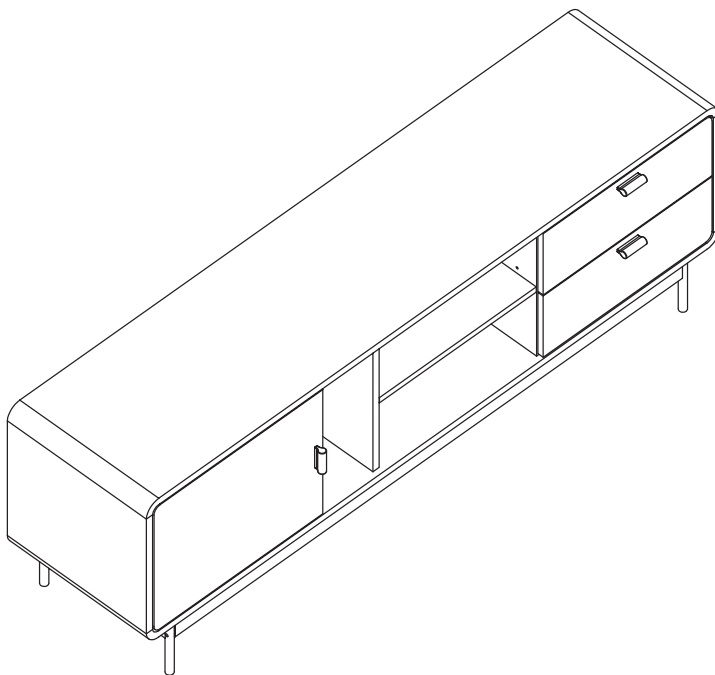

South  Shore

southshorefurniture.com

Production Code / Code de production / Código producción _____

**

** This number should be kept for all service request. / Ce numéro devra être conservé pour toute demande de service. / Conserve este número para cualquier solicitud de servicio.

ASSEMBLY INSTRUCTIONS #10042788

INSTRUCTIONS D'ASSEMBLAGE / INSTRUCTIVO DE ARMADO

A customer service available 7 days a week to answer all your needs

South Shore is a family company based in Quebec. We design our own pieces, and make them in house, so we're never far away when you call us with a question or concern. Our team is in constant contact with our design, production and distribution teams, making it easy to find answers for you — whether it's a five-minute call or an hour-long tutorial on how to assemble a storage unit. When we put so much time into crafting our pieces, why would we put a limit on support?

Servicio al cliente disponible los 7 días de la semana para satisfacer todas sus necesidades.

South Shore es una empresa familiar con sede en Quebec. Diseñamos nuestras propias piezas. El poder estar en constante contacto con nuestro equipo de diseño, de producción y de distribución, nos permite conseguir respuestas a todas sus preguntas, ya sea por una simple llamada de cinco minutos o incluso por un tutorial de una hora para ayudarlo a ensamblar sus muebles. Destinamos tanto tiempo a la creación de nuestros productos, que sería una locura limitar nuestro apoyo y nuestro servicio.

Un service client disponible 7 jours sur 7 pour répondre à tous vos besoins

South Shore est une entreprise familiale basée à Québec. On conçoit nos propres produits. Constamment en contact avec nos équipes de conception, de production et de distribution, c'est facile pour nous d'obtenir les réponses à vos questions — que ce soit pour un simple appel de cinq minutes ou encore pour un tutoriel d'une heure afin de vous aider à assembler votre meuble. On consacre tellement de temps à la création de nos produits, ce serait fou de limiter notre accompagnement et notre service!



**For any question
Pour toute question**
Para cualquier duda



**Call us
Appelez-nous
llámenos**
USA & Canada : 1-800-290-0465
Mexico : 001-800-514-5320
o al 800-522-6796



**Send an Email at
Envoyez-nous un courriel au**
Envianos un email al

service@southshorefurniture.com

1-YEAR WARRANTY / GARANTIE D'UN AN / GARANTÍA DE UN AÑO

Your peace of mind is guaranteed!

We are committed to offering durable furniture and accessories that will last for many years to come. That's why all our products are covered by a warranty.

La paix d'esprit, c'est garanti!

Nous avons à cœur de vous offrir des meubles et accessoires durables qui sauront vous accompagner pour de nombreuses années à venir. C'est pourquoi ils sont tous couverts par une garantie selon le type de produit.

¡Tu tranquilidad está garantizada!

Estamos comprometidos en ofrecer muebles y accesorios duraderos por muchos años. Esa es la razón por la que nuestros productos están cubiertos por una garantía.

1-year warranty on furniture and accessories

This warranty covers all parts and components of your furniture against defects in materials and workmanship for a specified period of one (1) year for furniture manufactured by our partners. It is limited to the repair or replacement of parts. See the *Warranty* section on our website

Garantie sur les meubles et accessoires d'un (1) an

Cette garantie couvre toutes les pièces et composantes de vos meubles contre les défauts de matériaux et de main-d'œuvre pour une durée déterminée d'un (1) an pour les meubles manufacturés par nos partenaires. Elle se limite à la réparation ou au remplacement des

Garantía en muebles y accesorios de un (1) año

Esta garantía cubre todas las partes y componentes de nuestros muebles contra defectos en materiales y mano de obra por un período especificado de un (1) año para muebles fabricados por nuestros socios. Está limitada a la reparación o remplazo de las partes. Ver la sección de la

to know which coverage applies.

DOWNLOAD THE FULL WARRANTY



southshorefurniture.com/warranty-information

pièces. Consultez la section *Garantie* sur notre site Web pour connaître la couverture qui s'applique.

TÉLÉCHARGER LA GARANTIE COMPLÈTE



southshorefurniture.com/warranty-information

Garantía en nuestra página web para saber que cobertura es aplicable.

BAJAR LA GARANTÍA COMPLETA



southshorefurniture.com/warranty-information



Register your product now!

Enregistrez votre produit dès maintenant!

¡Registre su producto ahora!



WARNING / AVERTISSEMENTS / ADVERTENCIA

Serious or fatal crushing injuries can occur from furniture tip-over. To help prevent tip-over:

- It is important to place the safety bracket included.
- Place heaviest items in the lowest storage space.
- Never allow children to climb or hang on drawers, doors, or shelves.
- Never open more than one drawer at a time.
- If a heavy object is placed on top or inside the furniture, consider this risk

Use of tip-over restraints reduce, but does not eliminate, the risk of tip-over.

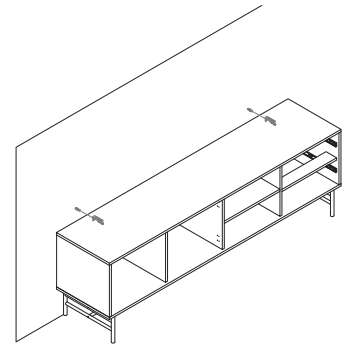

Des blessures graves ou fatales peuvent résulter de basculement du meuble. Afin de prévenir le basculement:

- Il est important d'installer le crochet de sécurité inclus.
- Placer les items les plus lourds dans les espaces de rangement du bas.
- Ne jamais laisser un enfant grimper sur les tiroirs, les portes et les tablettes ou s'accrocher à ceux-ci.
- Ne jamais ouvrir plus d'un tiroir à la fois.
- Si un objet lourd est placé sur l'unité ou à l'intérieur, considérez le risque de basculement.

L'utilisation de dispositif antibasculement réduit les risques de basculement, sans les éliminer totalement.

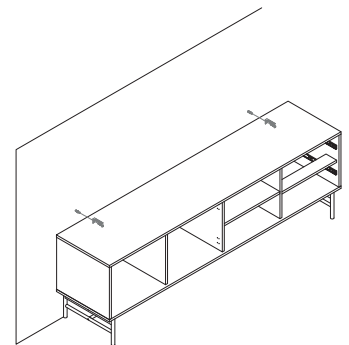

El volcadura del mueble puede ser causa de lesiones graves o de un atropellamiento fatal. Para evitar la volcadura :

- Es importante instalar el gancho de seguridad.
- Ponga las cosas pesadas en los compartimentos más bajos.
- Nunca permita que un niño se suba o se cuelgue en cajones, puertas o estantes.
- Nunca abra más de un cajón a la vez.
- Si un objeto pesado está colocado dentro o sobre el mueble, considere el riesgo de que se puede voltear.

El uso de sujetadores para evitar la volcadura sólo puede disminuir el riesgo de una volcadura, pero no lo elimina.

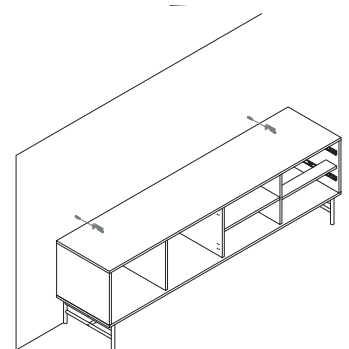

1

Collect the pieces together
Rassembler les morceaux ensemble
Poner las piezas juntas

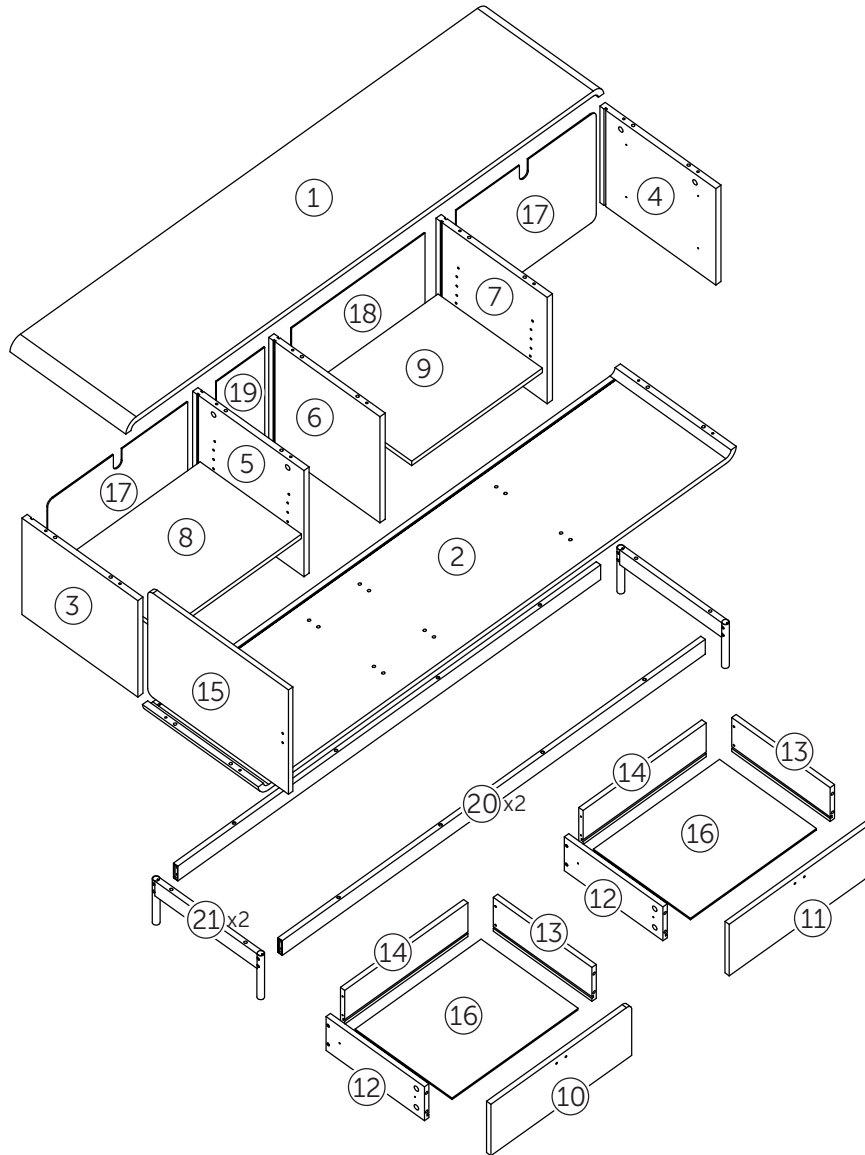
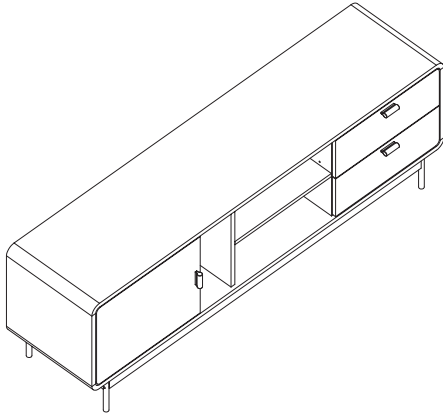

2

Let's get handy!
Mettons-nous au travail!
¡Vamos a ponernos prácticos!

01

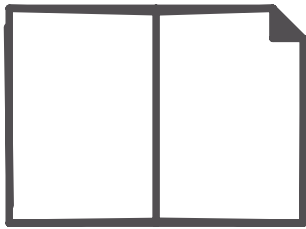

02



03

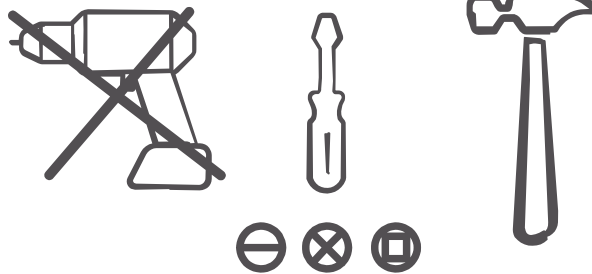

04

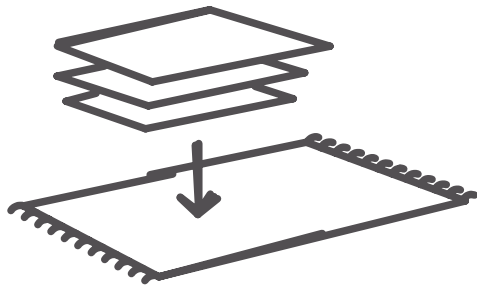

05



3

Collect the Hardware Rassembler la quincaillerie Reunir los articulos de ferreteria

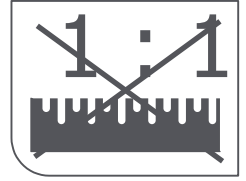

A (x22)



K (x2)



O (x8)



B (x22)



L (x2)



C (x20)



M (x2)



D (x42)



N (x14)



E (x6)



O (x8)



F (x1)



P (x8)



G (x3)

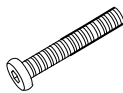

Q (x12)



H (x6)

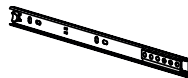

R (x4)



I (x2)



S (x4)



J (x2)



T (x8)

*Hardware package may have spare parts.

*Le sac de quincaillerie peut contenir des pièces de remplacement.

*La bolsa de herraje puede contener piezas adicionales de repuesto.

4

4.1

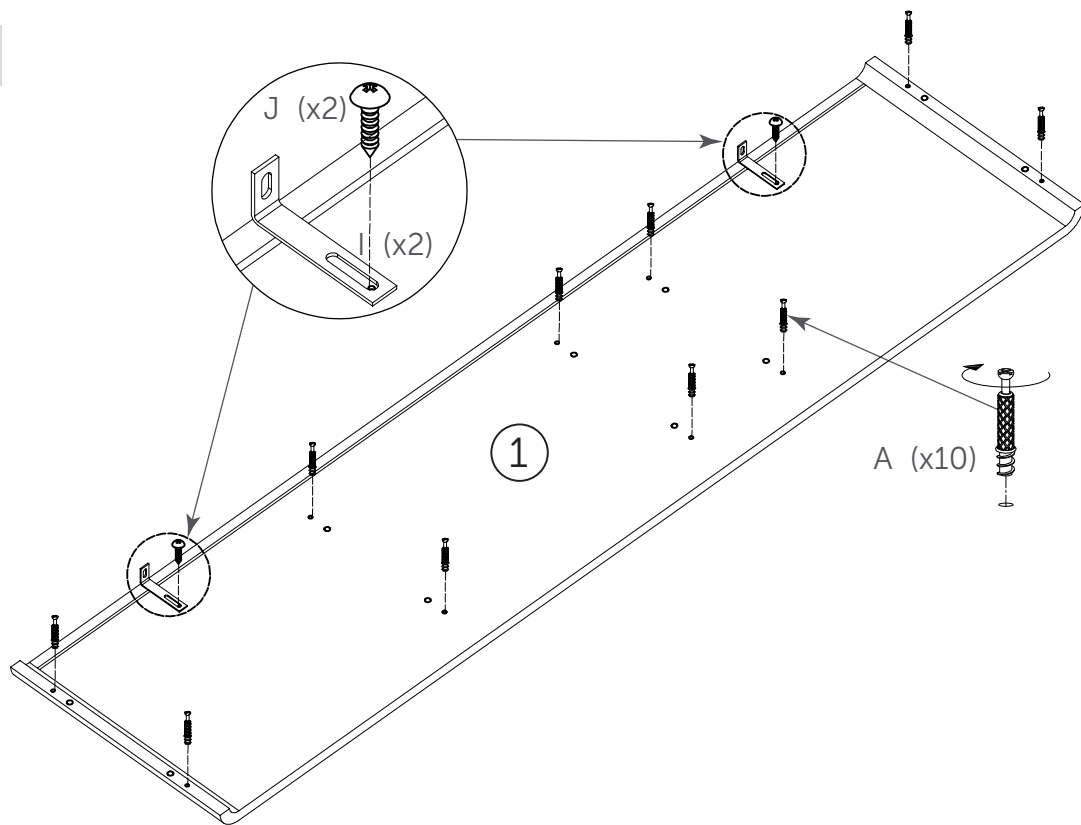

4.2

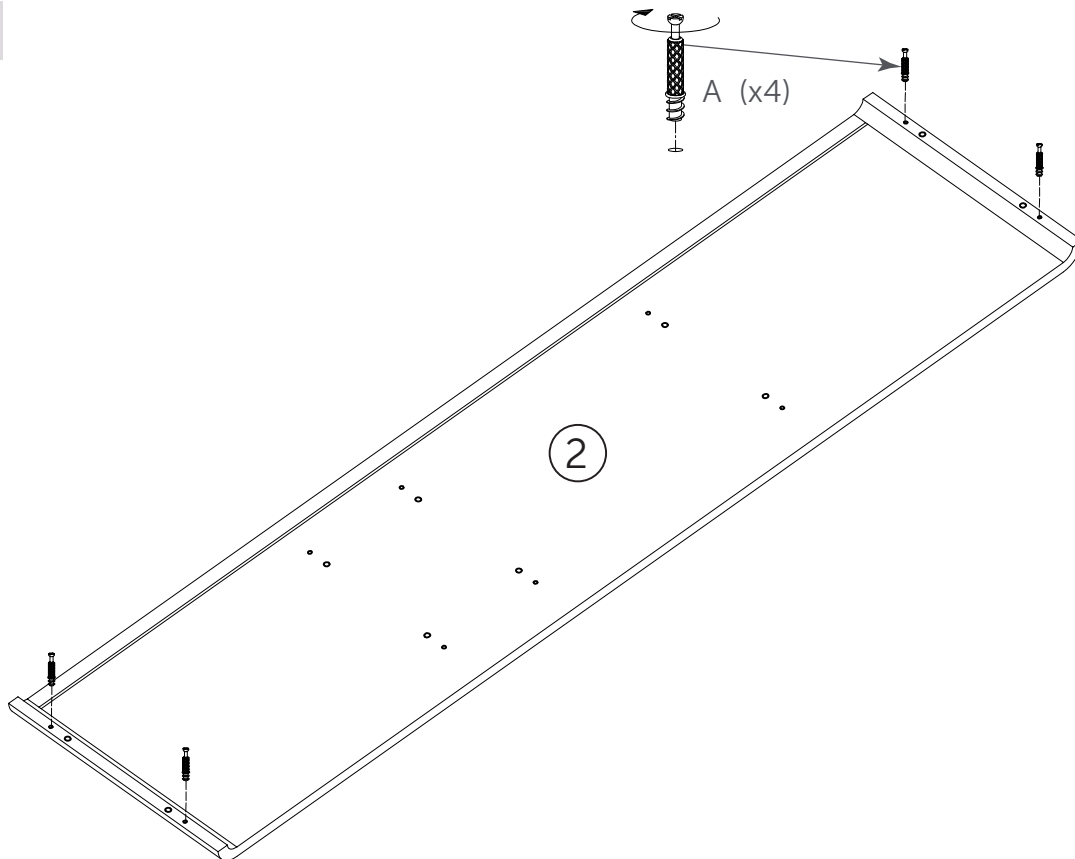

5

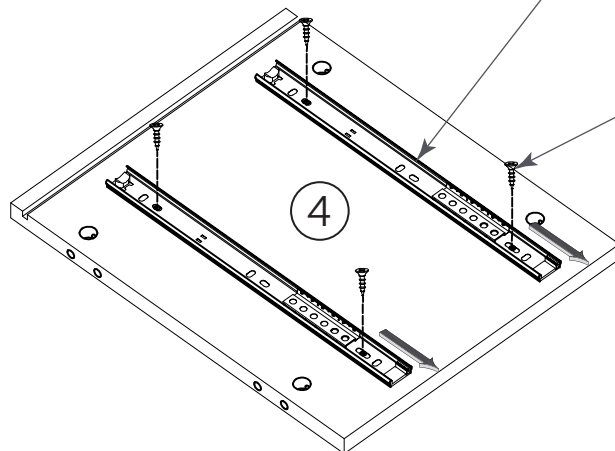
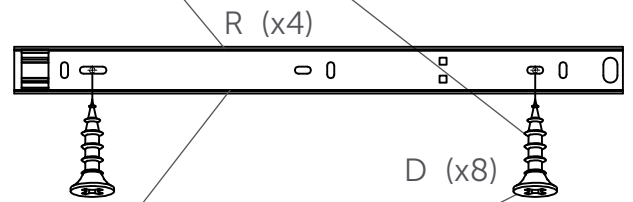
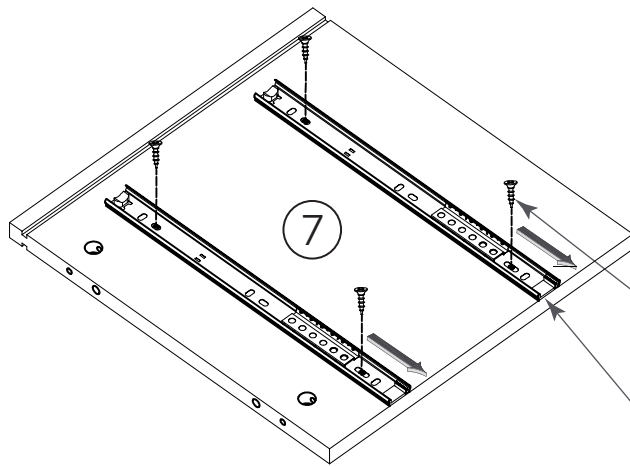
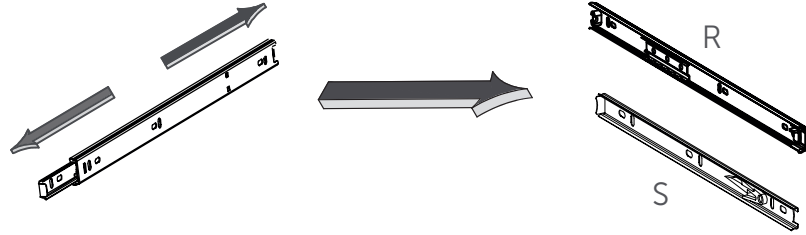
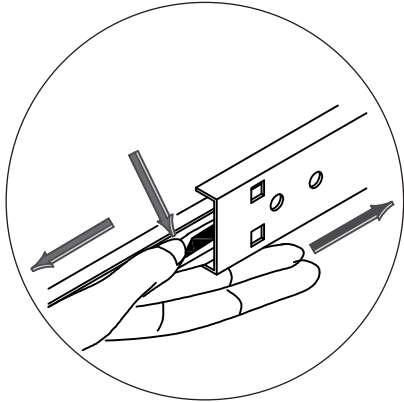
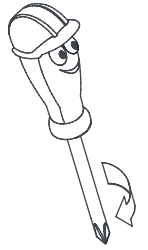

6

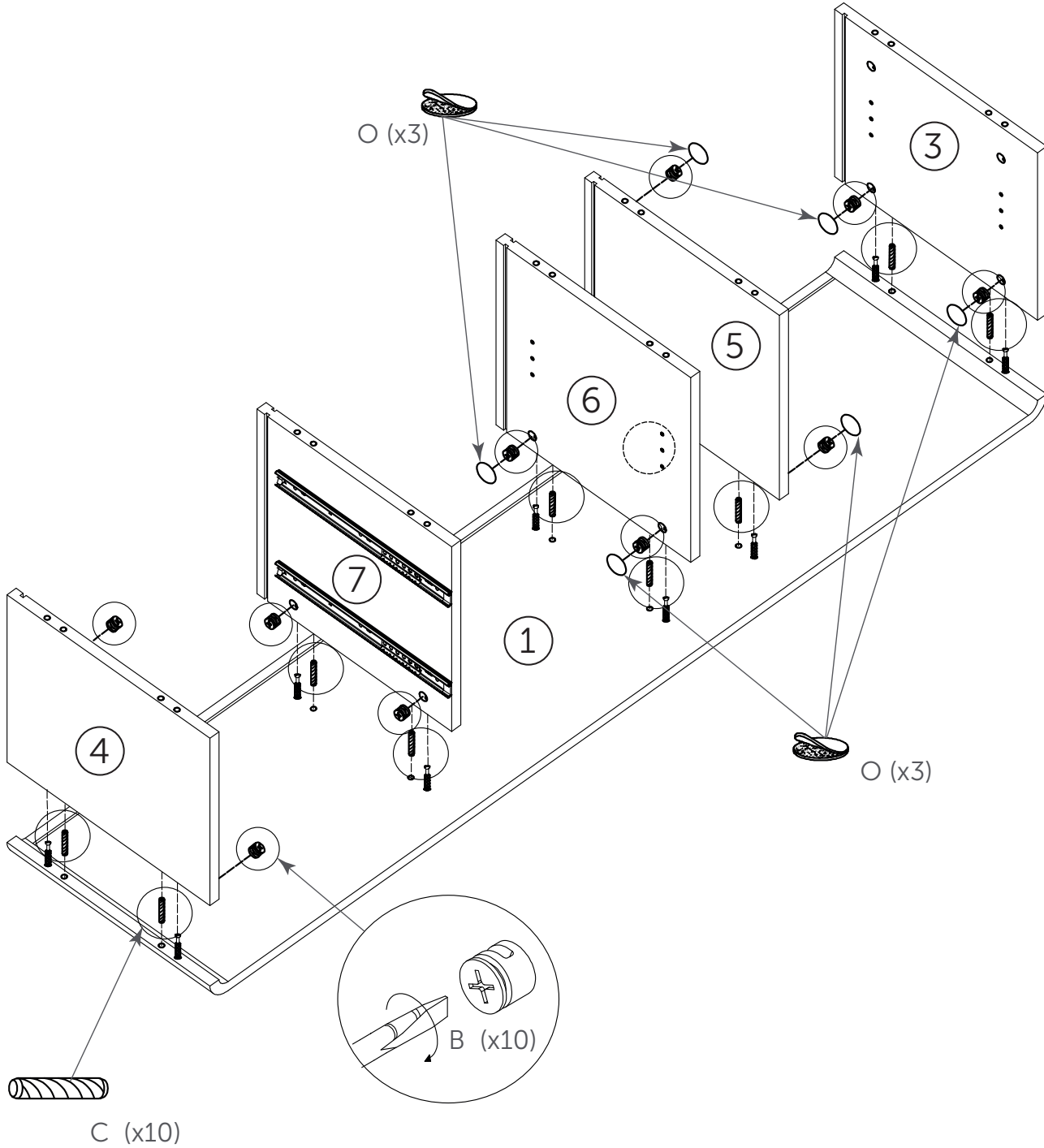
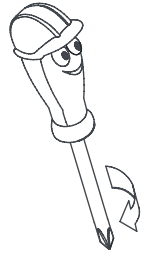

7

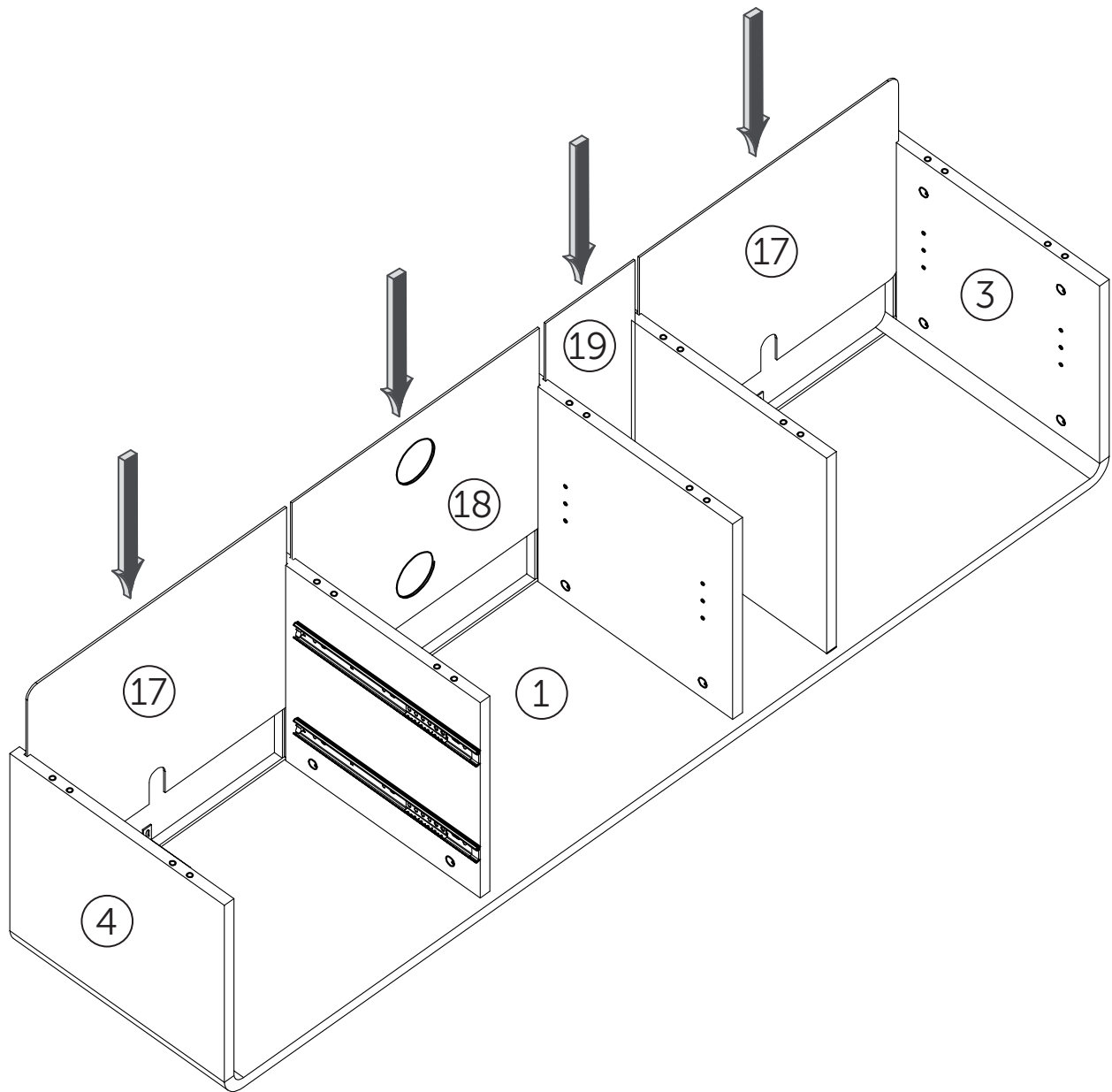

8

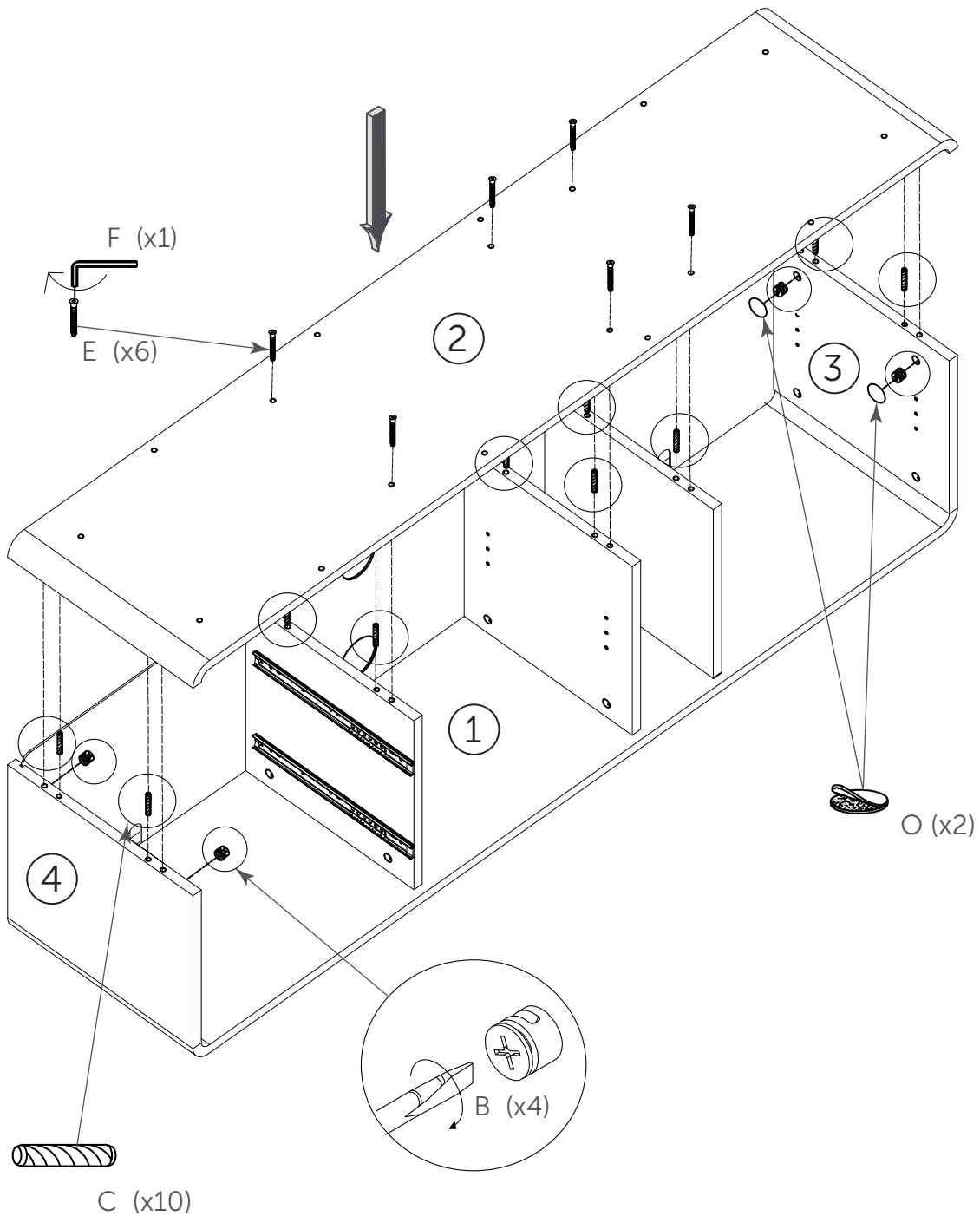
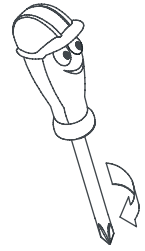

9

9.1

F (x1)
P (x8)

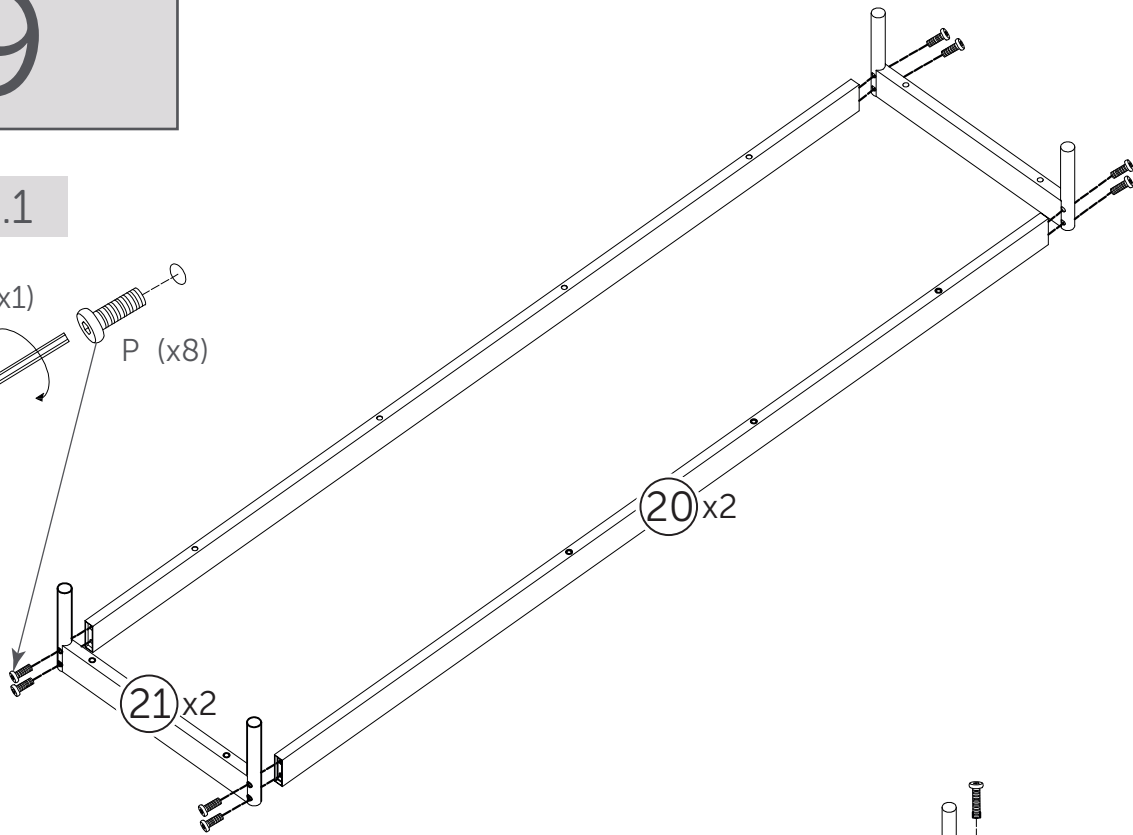

9.2

F (x1)
Q (x12)

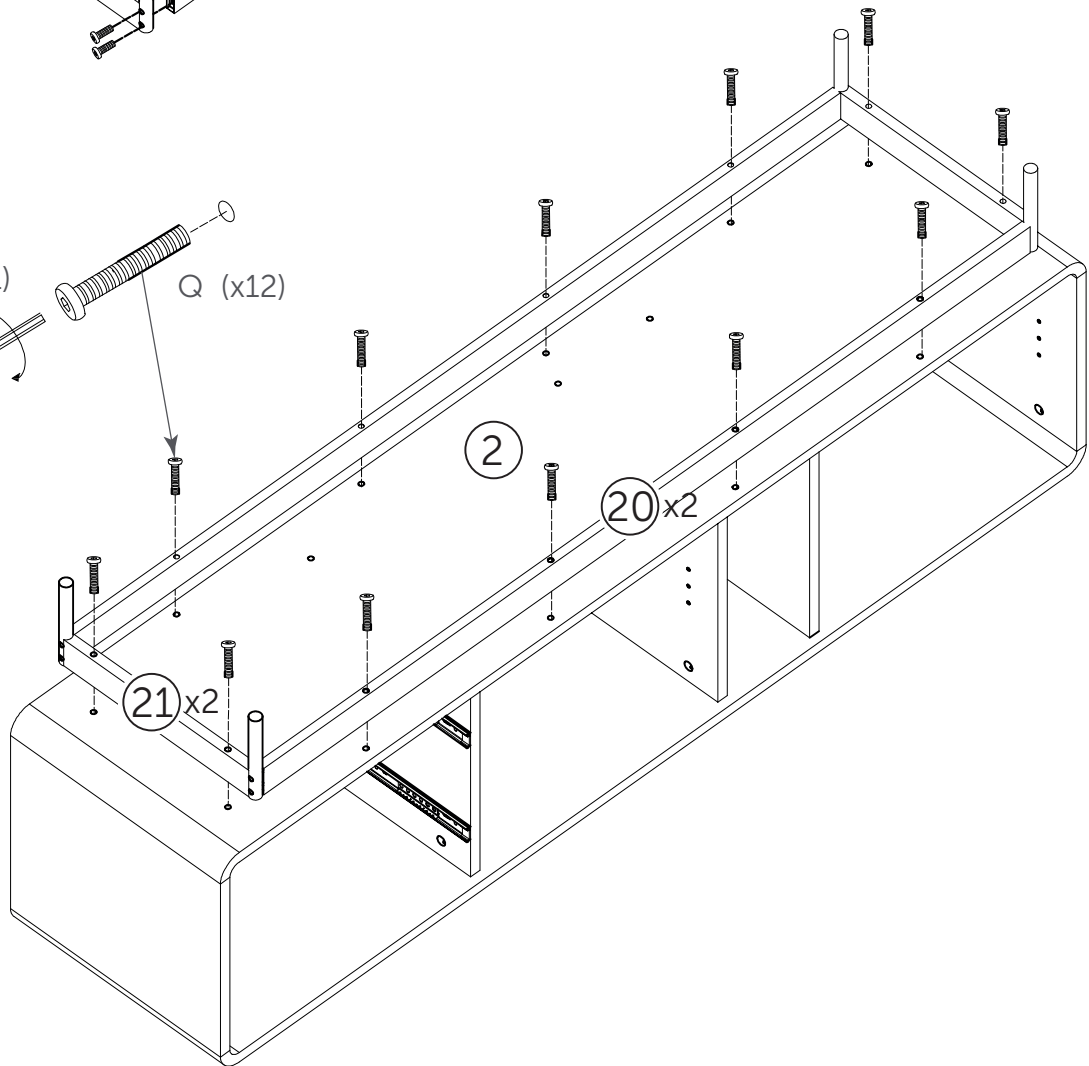

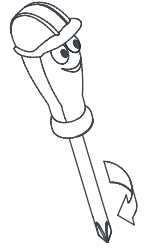

Flip furniture
Tourner le meuble
Girar el mueble

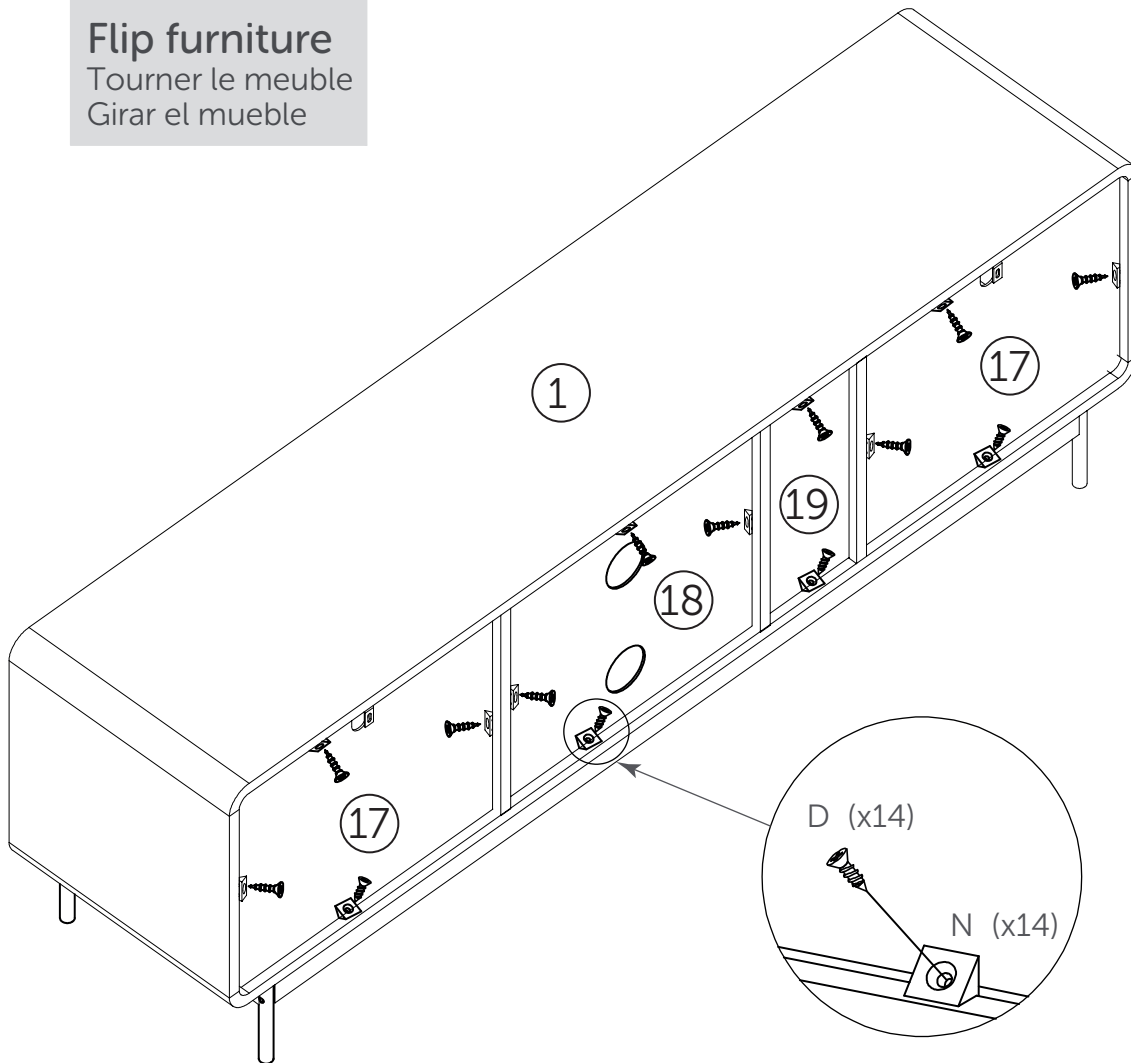

11

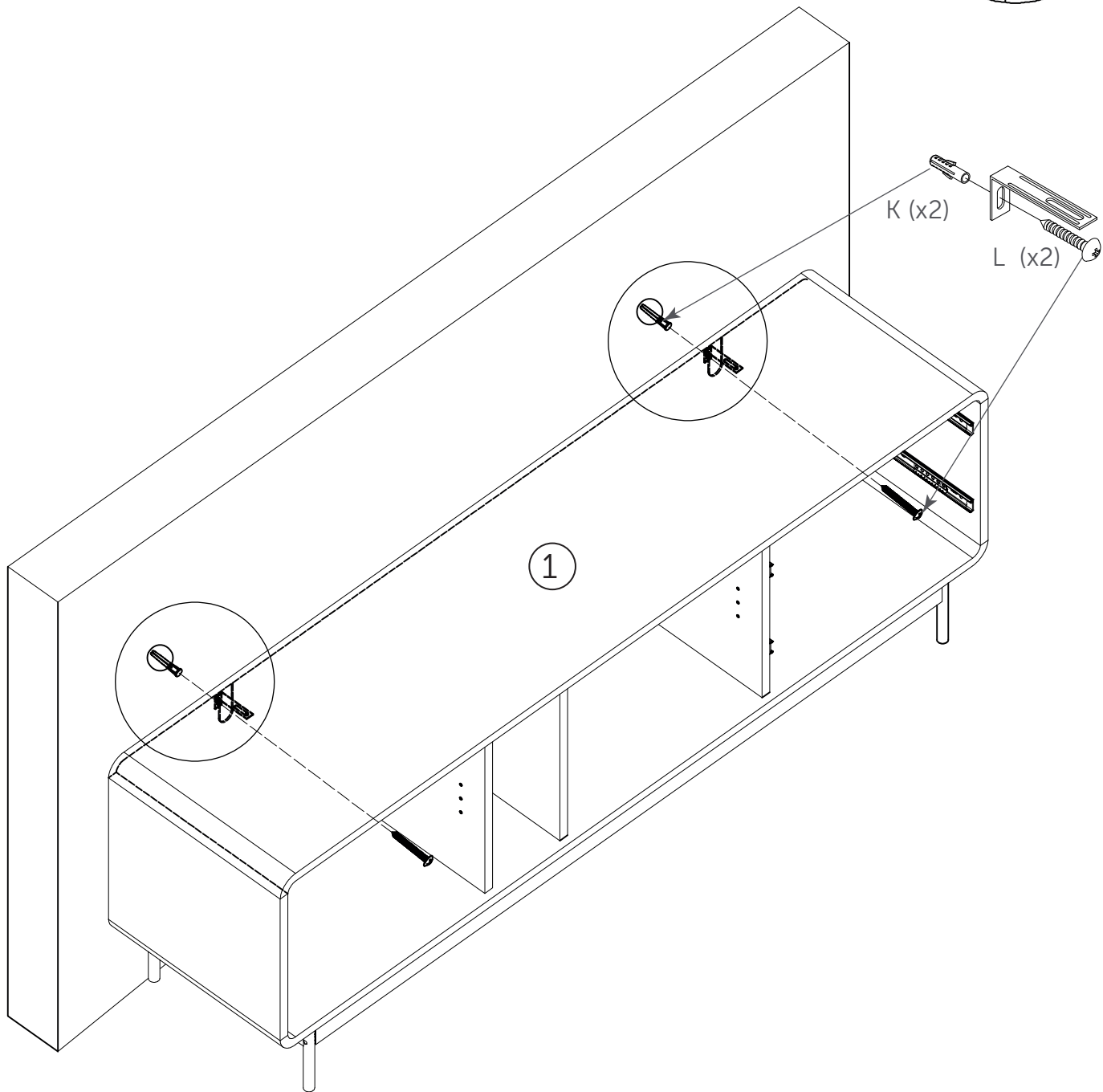
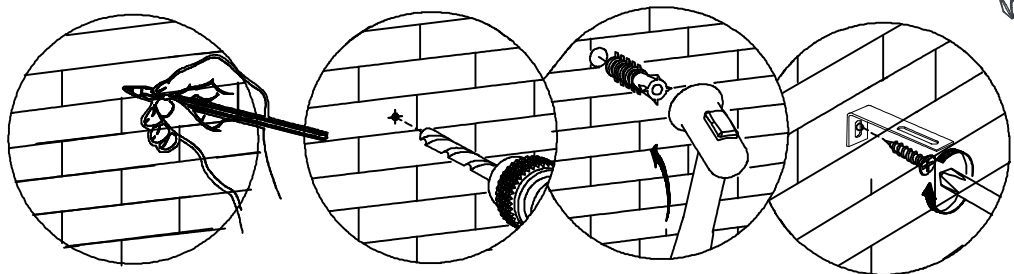
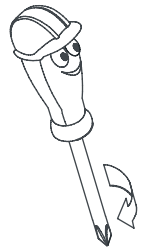

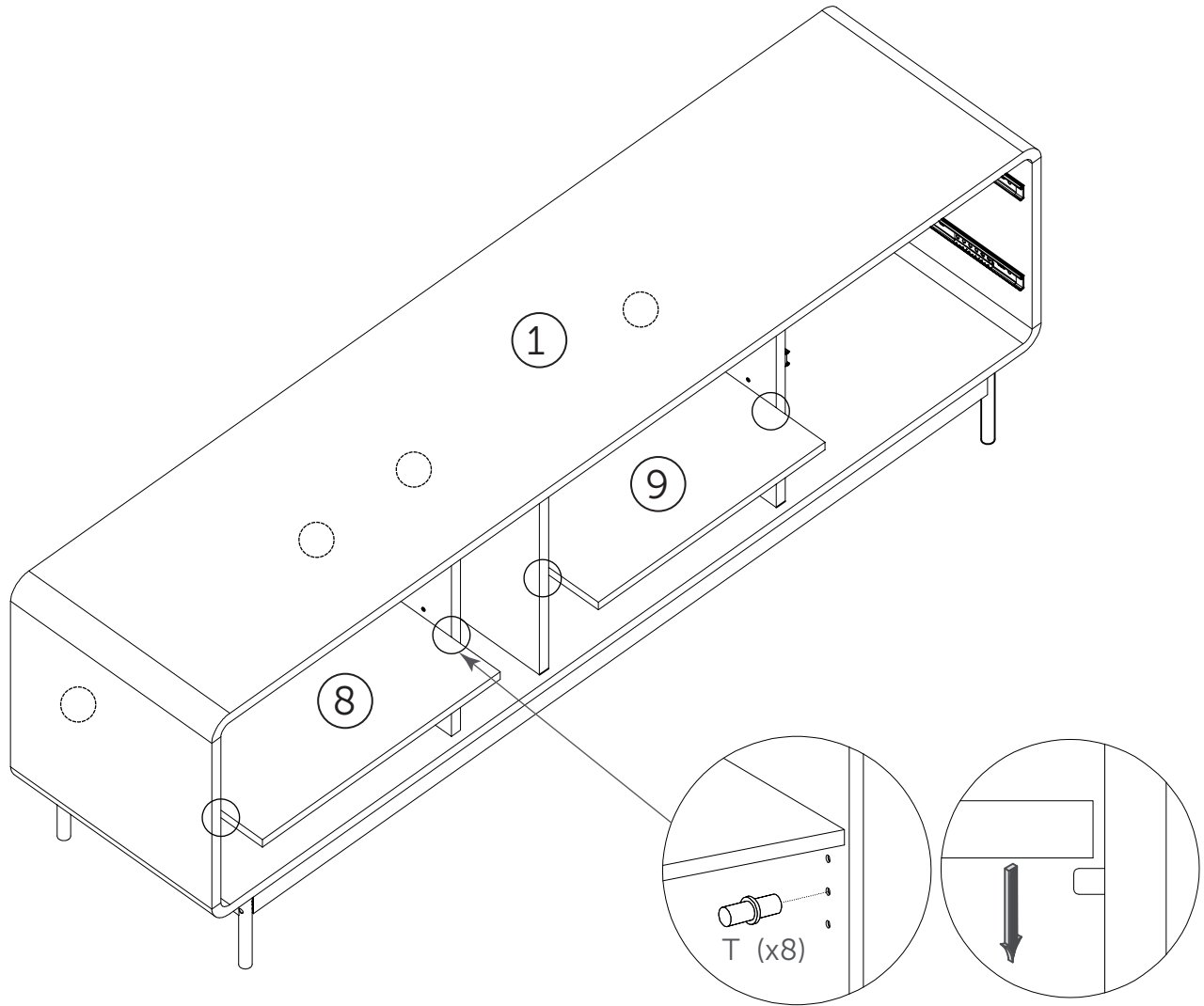

13

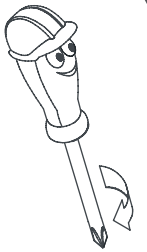

13.1

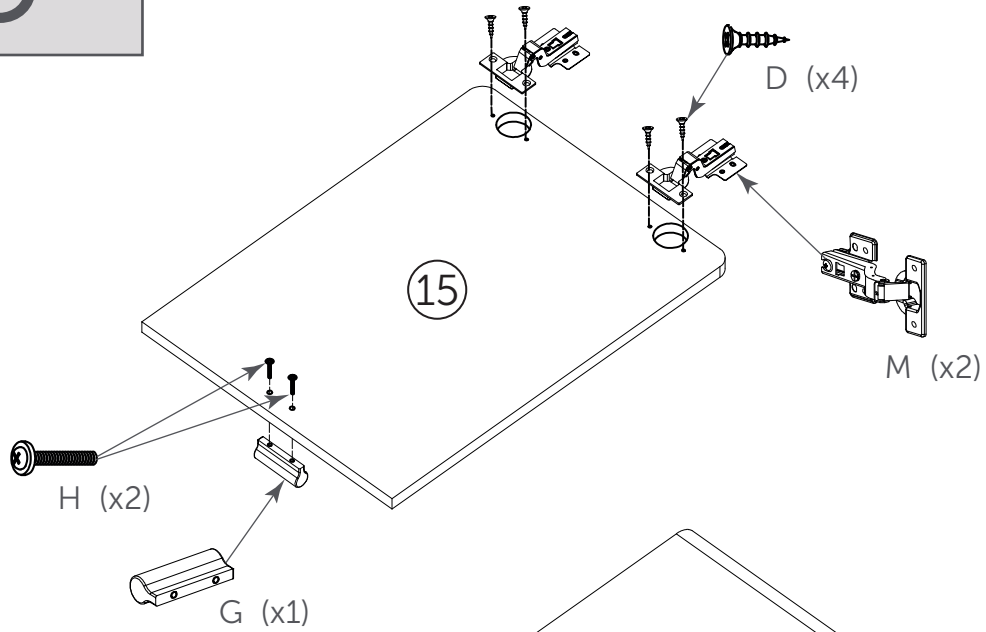

13.2

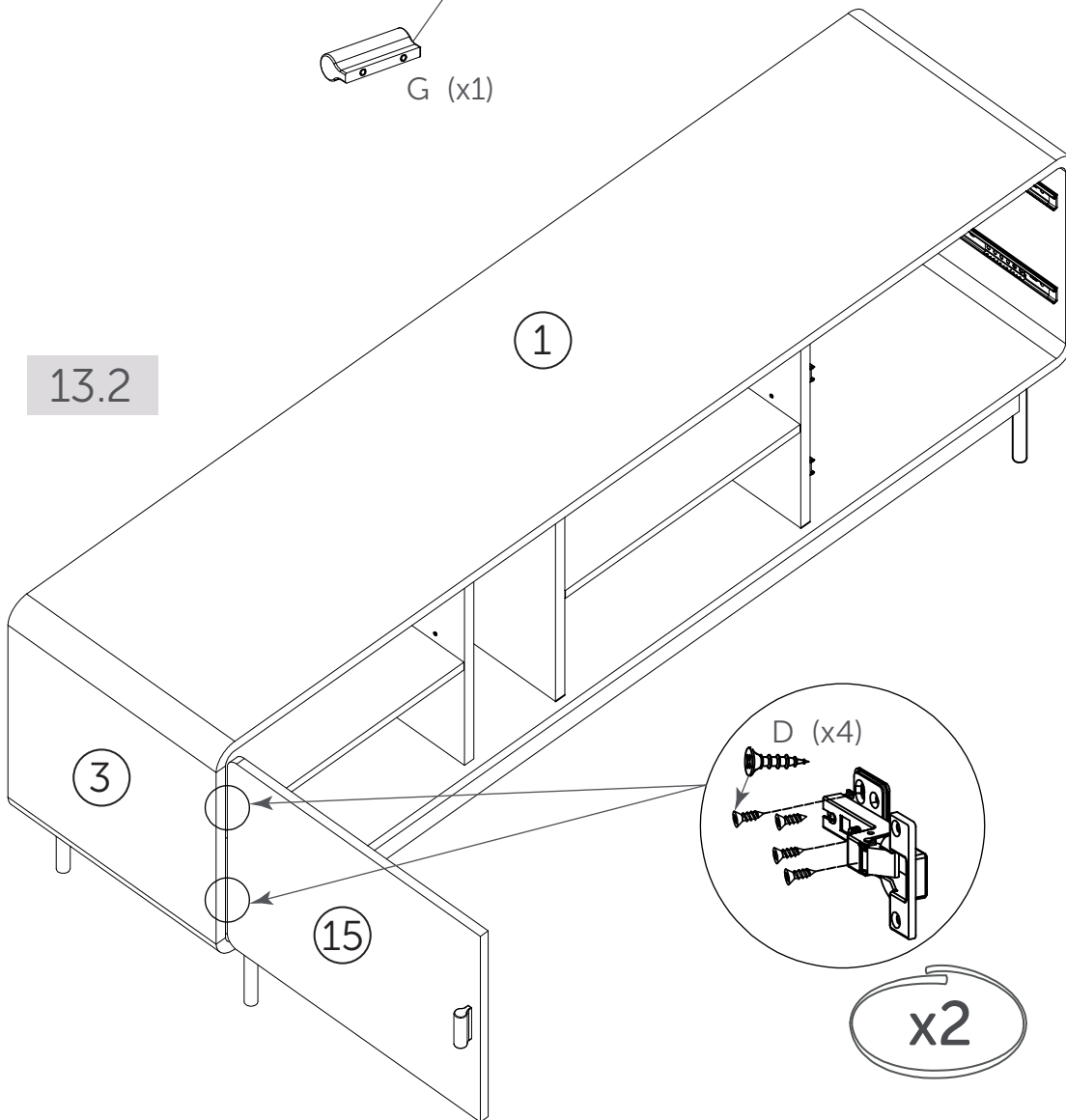

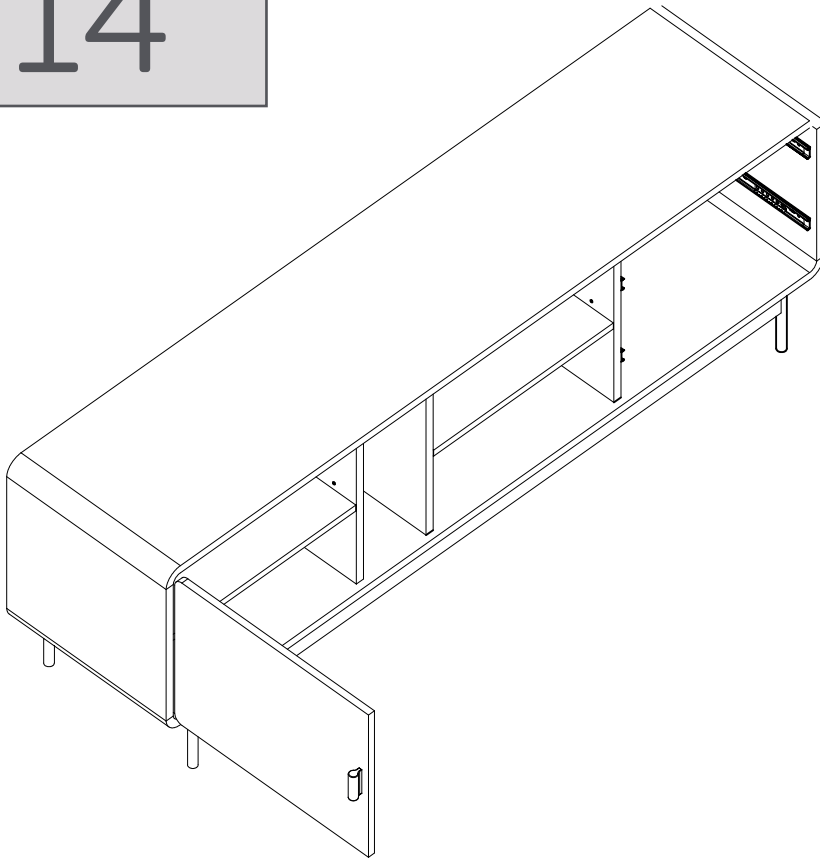
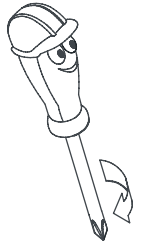

* Doors ajustement (Hinges)

* Ajustement des portes (Charnières)

* Ajuste de las puertas (Bisagras)

* Make sure the unit is level.

* Loosen the concerned screw(s), adjust, and tighten.

* Assurez-vous que le meuble soit au niveau.

* Déserrer la(les) vis concernée(s), ajuster, et resserrer.

* Cerciorarse de que la unidad se encuentre a nivel.

* Desapretar los atornillos apropiados, ajustar, y apretar.

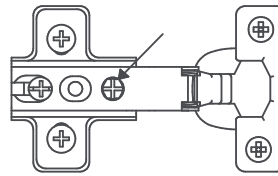

Left/Right

Gauche/Droite

Izquierda/Derecha

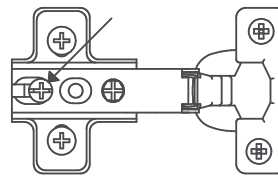
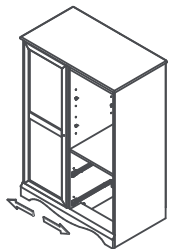

Depth

Profondeur

Profundidad

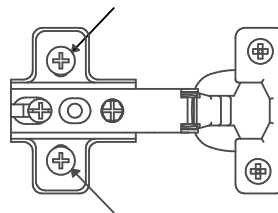
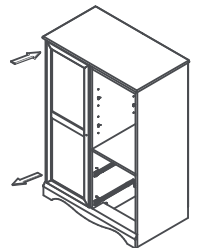

Height

Hauteur

Altura

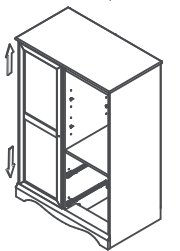

15

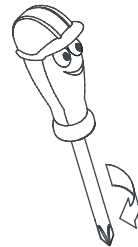

15.1

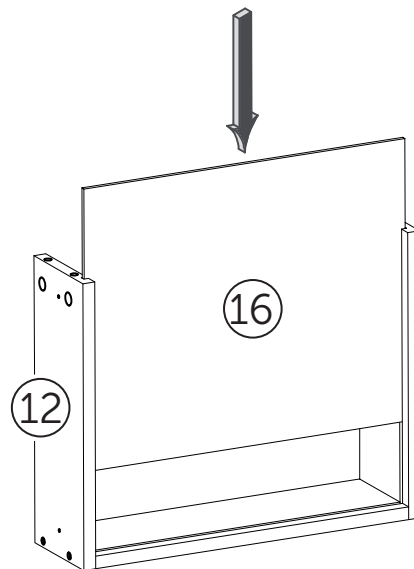
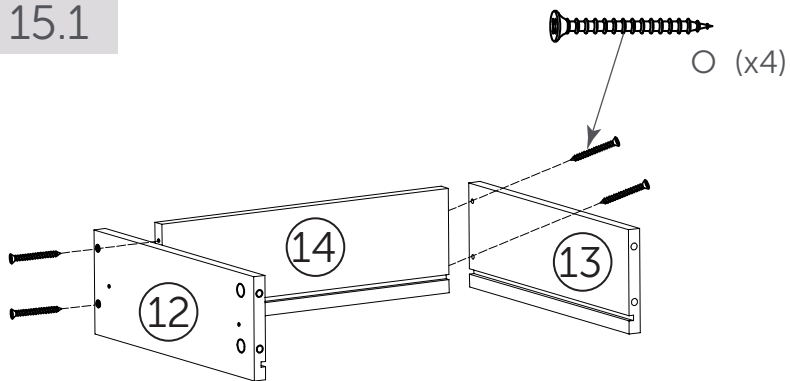

x2

15.2

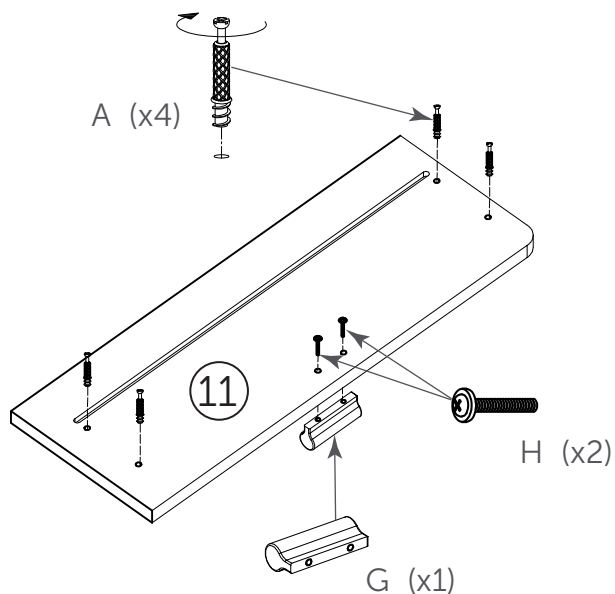
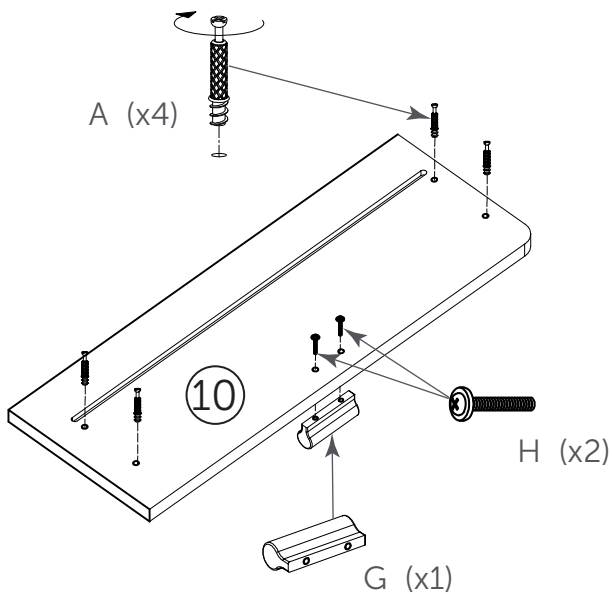

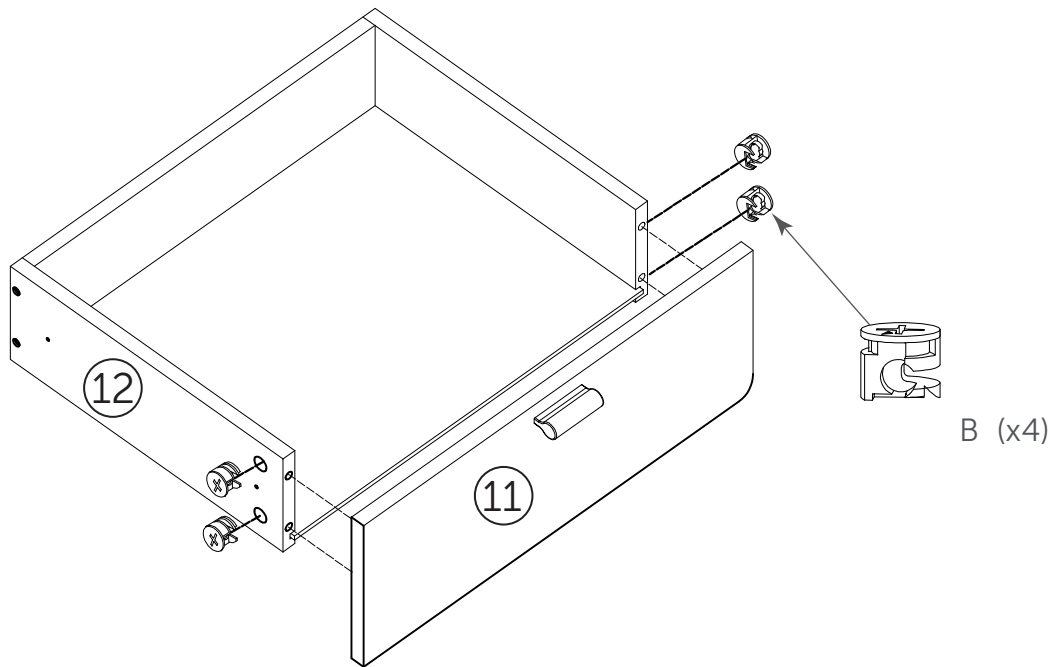
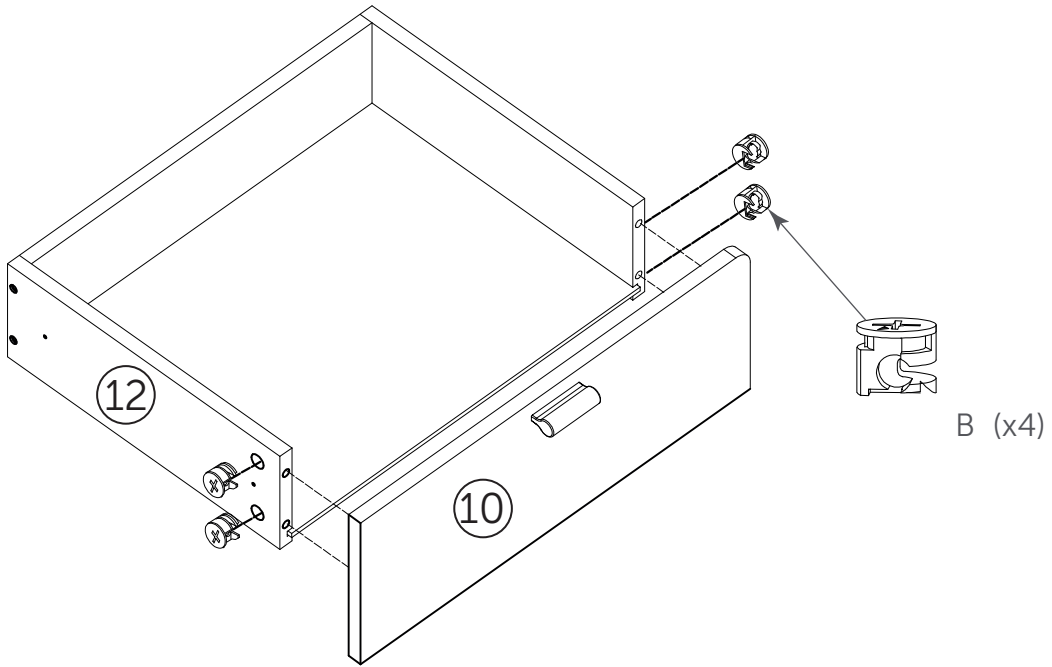
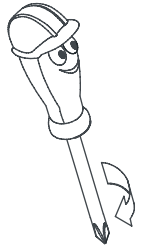

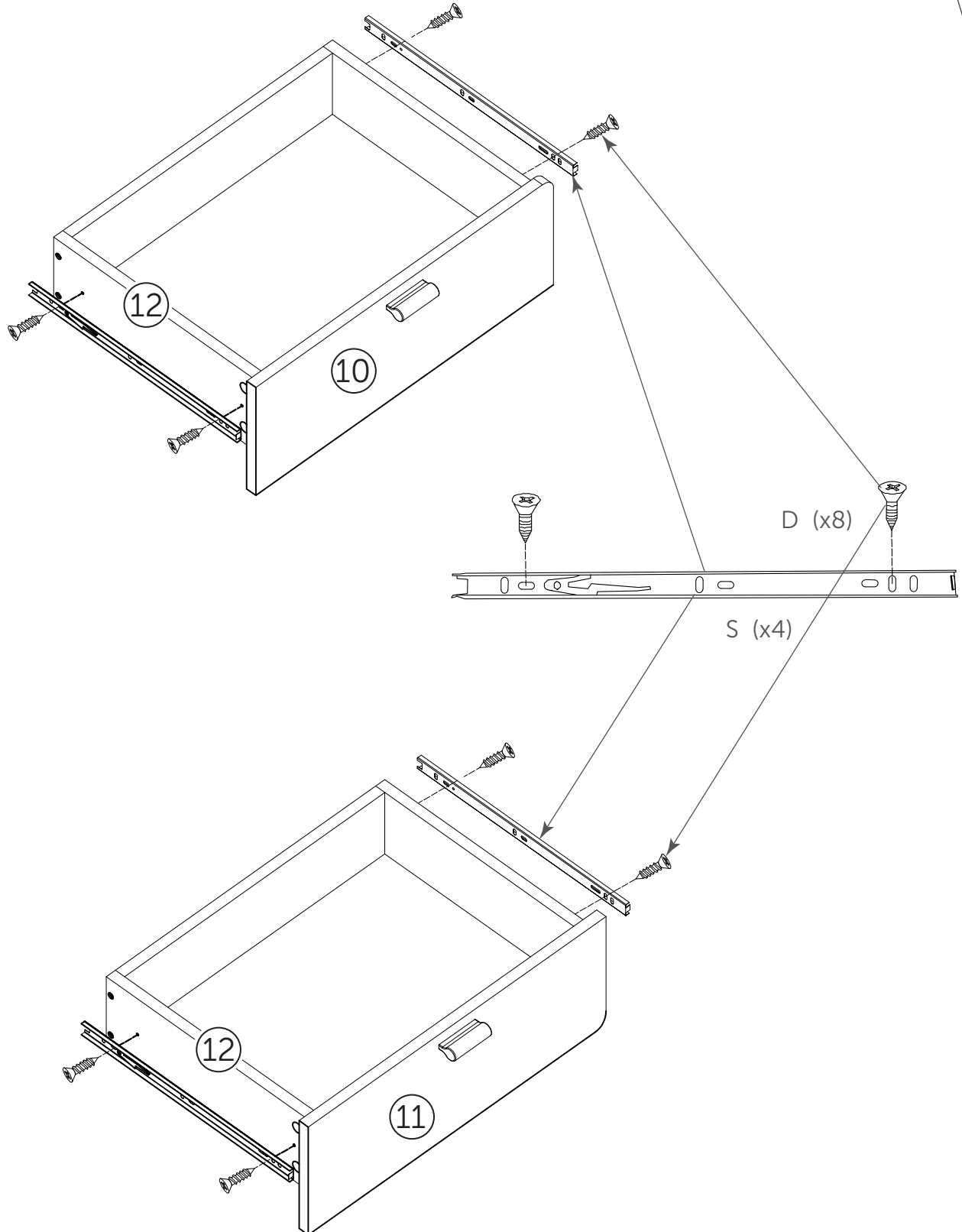
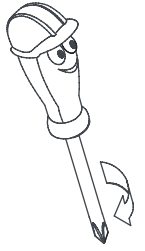

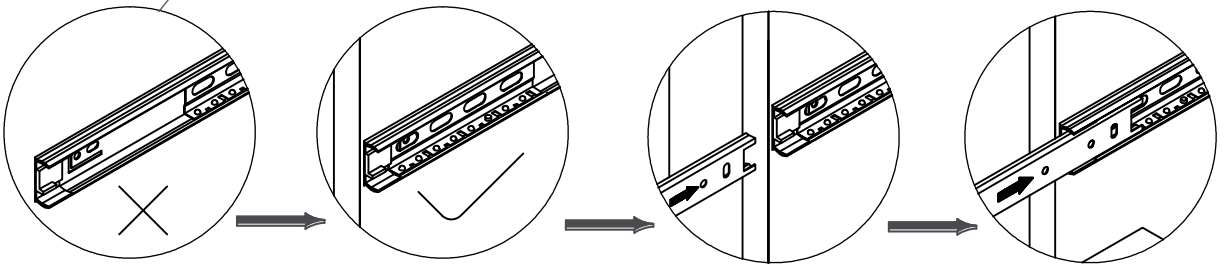
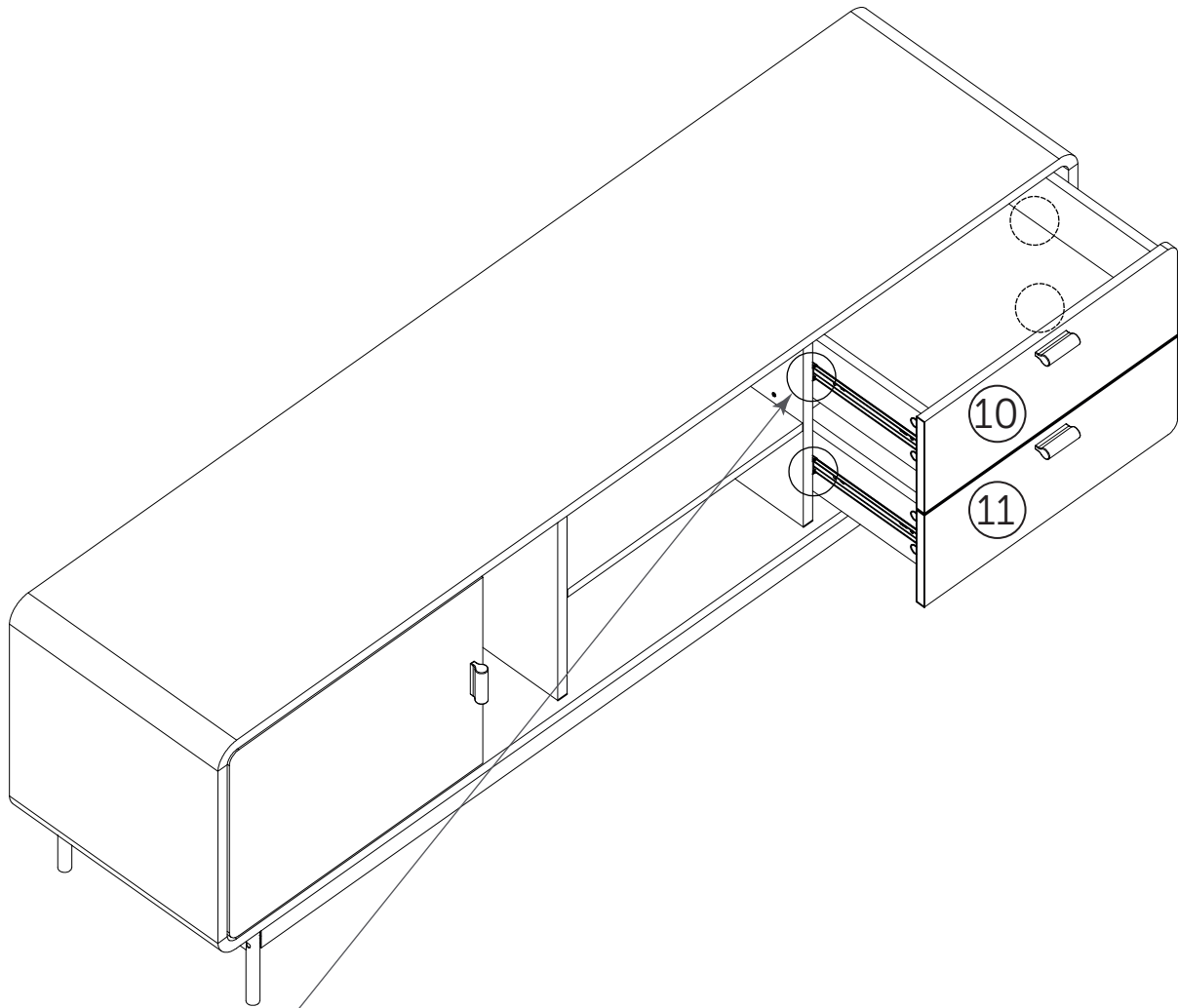

WEIGHT

POIDS

PESO

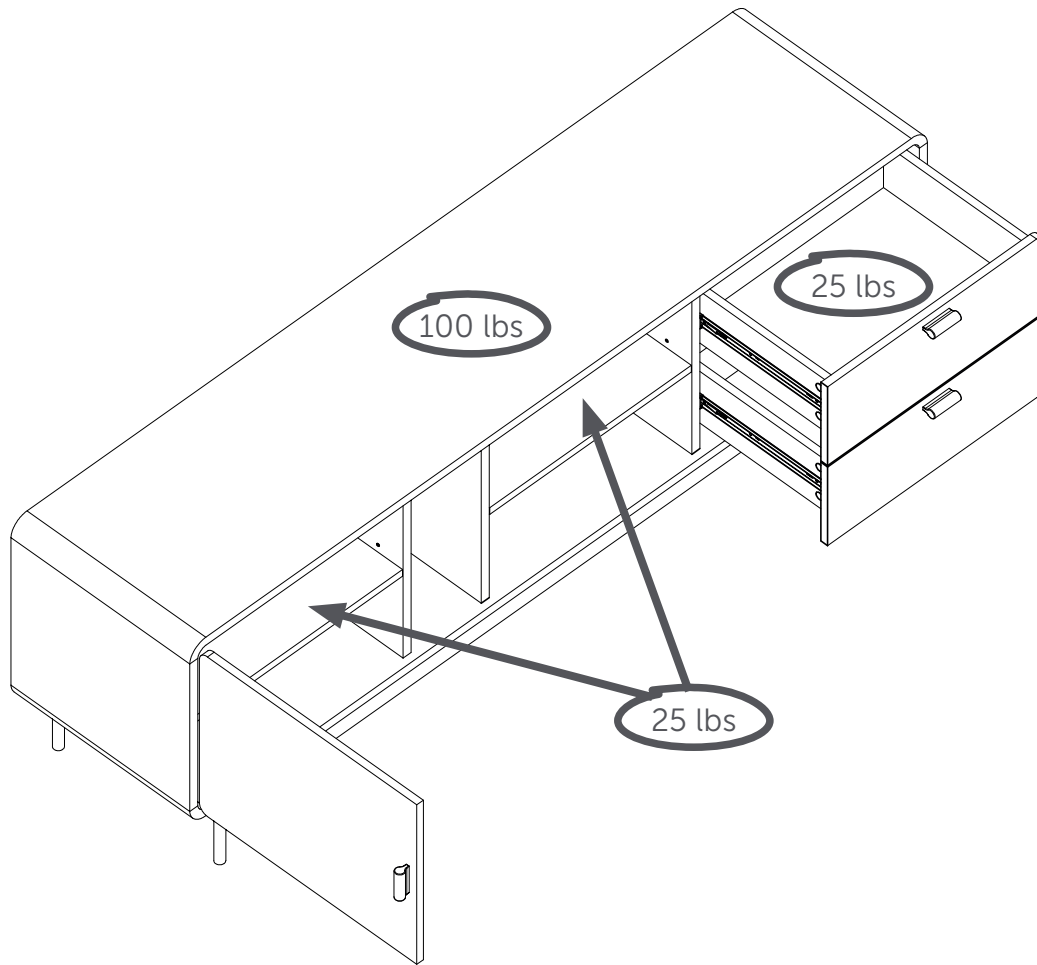

This South Shore Furniture product is designed to withstand the weight indicated above. We are not responsible for the breakage of parts or any injury caused by the failure to comply with this recommendation.

Ce produit de Meubles South Shore a été conçu pour résister aux poids mentionnés ci-haut. Nous ne sommes pas responsables du bris des pièces ou de toute blessure occasionnée par le non-respect de cette recommandation.

Este producto de las industrias South Shore ha sido concebido para resistir el peso que se menciona aquí. No somos responsables del daño de piezas o cualquier otra lesión ocasionada por no cumplir con esta recomendación.

MAINTENANCE TIPS

CONSEIL D'ENTRETIEN / CONSEJOS DE MANTENIMIENTO



Never let liquids or damp cloths sit on this furniture.
Ne jamais laisser de liquide ou linge humide sur le meuble.
Nunca deje un líquido o un trapo húmedo sobre el mueble.



Never use chemical cleaning products. They can damage the finish. For cleaning, use only a slightly damp cloth and wipe dry.
Ne jamais utiliser de produits nettoyants à base de produits chimiques, cela va endommager le fini. Utiliser seulement un linge légèrement humide.
Nunca utilice limpiadores a base de químicos, estos dañaran le acabado. Us e sólo un paño húmedo.

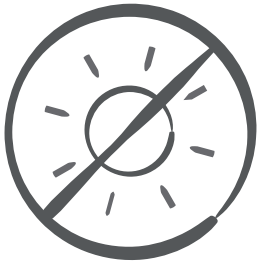

To avoid dulling of the finish, do not place furniture in direct sunlight.
Ne pas placer le meuble directement au soleil pour prévenir le ternissement.
No exponga el mueble directamente al sol para prevenir empañamiento.



Do not put plastic or rubber rings under appliances.
Use cloth or felt protectors.
Évitez de déposer des appareils avec des rondelles de plastique ou de caoutchouc. Utilisez un protecteur en tissu ou en feutre.
Evite apoyar aparatos con redondeles de plástico o de goma. Utilizar un protector de tela o de fieltro.



To clean, use a soft or slightly damp cloth, then wipe with a clean, dry cloth.
Pour nettoyer, utilisez un linge doux ou légèrement humecté. Essuyez par la suite avec un linge propre et sec.
Para limpiar, utilice un trapo suave o ligeramente humedecido. Seque luego con un trapo limpio y seco.

You're our inspiration and we hearing from you!

Give us a call if you want to discuss a project. Or hop over to our social media platforms and share your design stories.

The door is always open.

#southshorehome   

Take a look at our website: we have tons of ideas to go with your new piece of furniture!

www.southshorefurniture.com

Want to take sneak peek at new arrivals and get some useful tips?
Subscribe to our newsletter!

Vous êtes notre inspiration et nous recevoir de vos nouvelles!

Appelez-nous si vous voulez discuter d'un projet ou rejoignez nos médias sociaux pour partager vos histoires de design.

Notre porte est toujours ouverte.

#southshorehome   

Jetez un coup d'oeil à notre site internet. Nous avons des tonnes d'idées pour votre nouveau meuble !

www.southshorefurniture.com

Vous voulez avoir un aperçu de nos nouveaux arrivages et obtenir des conseils pratiques?
Inscrivez-vous à notre infolettre!

Usted es nuestra inspiración y nos tener noticias de usted.

Llámenos si desea discutir de su proyecto o síganos en nuestras redes sociales y comparta sus historias de diseño.

La puerta siempre está abierta para usted.

#southshorehome   

¡ Lo invitamos a echar un vistazo en nuestro sitio web, tenemos toneladas de ideas para su nuevo mueble !

www.southshorefurniture.com

¿ Quiere echar un vistazo a nuestras novedades y consejos prácticos ?
Suscribase a nuestro boletín.

South  *Shore*