

**WALKER EDISON**  
TM

# Chloe 60" TV Stand

SKU# WECHL21604

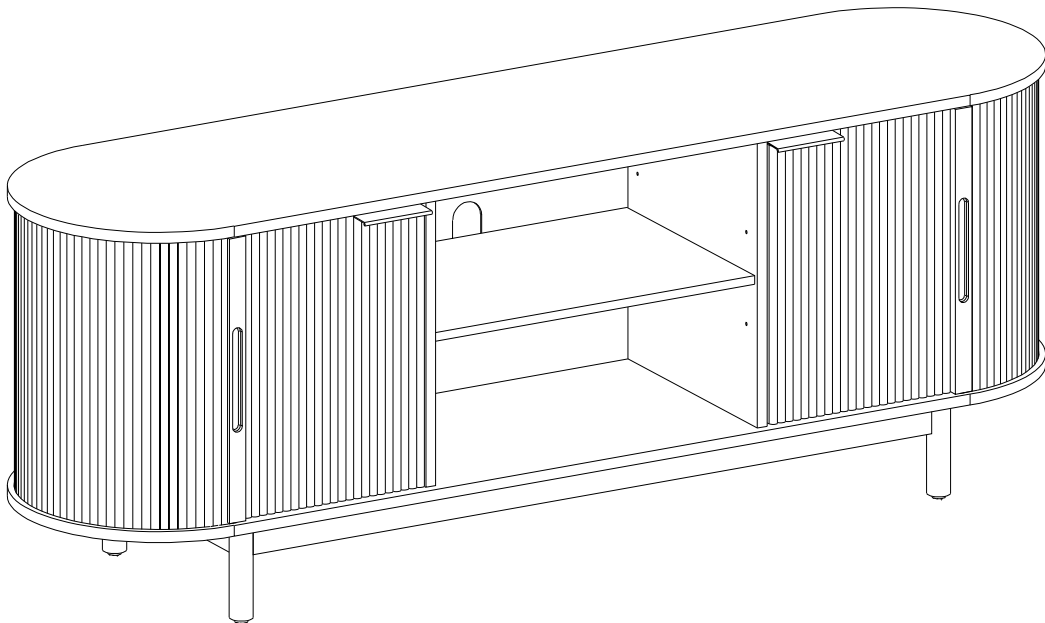

**For Residential Use Only**

Please visit our website for the most current instructions, assembly tips, report damage, or request parts. [www.walker-edison.com](http://www.walker-edison.com)



# Time to get started

Set up a clean and soft workplace to get started and avoid damage during the assembly. It also helps to double-check you've got all the pieces and parts before diving in to assembly.

Estimated time for assembly

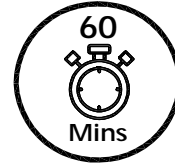

People recommended for assembly

Make it a team effort! Grab a friend for quicker, easier assembly.

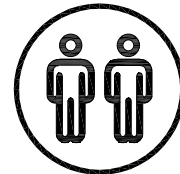

2 People Build

Tools Needed

Grab a Phillips head screwdriver to conquer this assembly

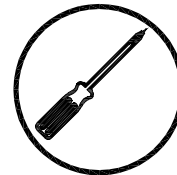

Use power tools with caution

You can cause cracking or damage to the material and easily strip the hardware. If you choose to use a power tool, your product will no longer be covered under Walker Edison' warranty.

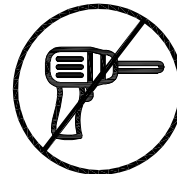

Glue is provided to secure wood dowels in place

When inserting dowels, locate the appropriate hole, place a small amount of glue in the hole, and then insert the dowel. Wipe away excess glue immediately.

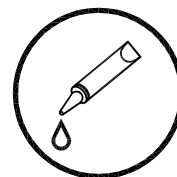

Chloe

Scan to get assembly tips and help!







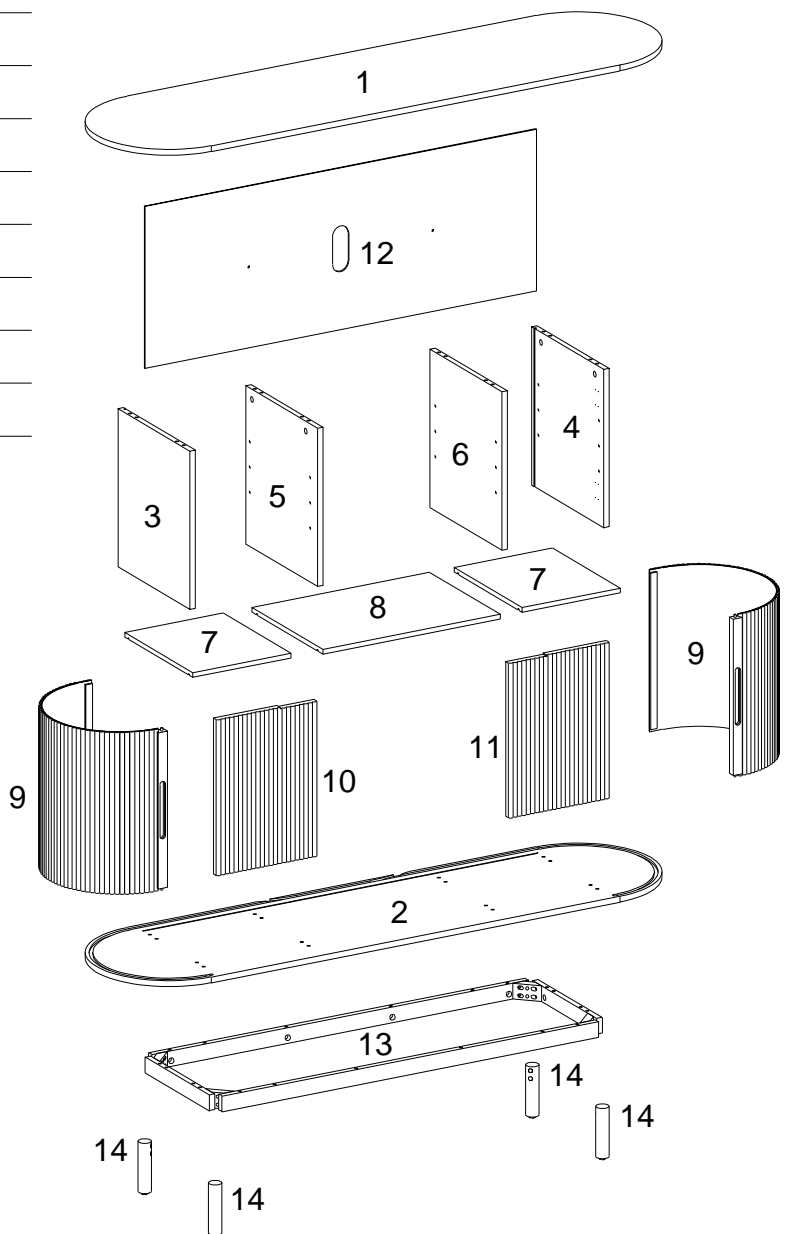

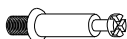

# Parts List

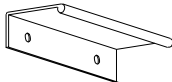
Part Number	Description	Quantity
1	Top Panel	1
2	Bottom Panel	1
3	Left Panel	1
4	Right Panel	1
5	Left Vertical Dividing Panel	1
6	Right Vertical Dividing Panel	1
7	Adjustable Side Shelf	2
8	Adjustable Middle Shelf	1
9	Sliding Door	2
10	Left Door	1
11	Right Door	1
12	Back Panel	1
13	Leg Frame	1
14	Leg	4

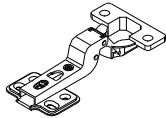

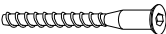





# WE Hardware List

Part	Size	Name	Quantity
A	 8x30mm	Wooden dowel	24
B	 6x35mm	Cam bolt	20
C	 15x11mm	Cam lock	20
D	 30mm	Sticker	20
E		Handle	2
F	 3x14mm	Screw	8
G		Door stopper	2
H	 26mm	European hinge	4
J	 3.5x14mm	Screw	24
K	 6x50mm	Bolt	8
L	 M4x57mm	Hex key	1
M	 8x5x16mm	Shelf support pin	12

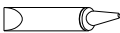

# Hardware List

Part	Size	Name	Quantity
N		Plastic wedge	8
P		3x17mm Screw	8
Q		6x50mm Bolt	8
R		11x1.5mm Lock washer	8
S		16x1mm Flat washer	8
T		8x3x15mm Screw	2
U		Wax	1
W		Glue tube	1

The hardware quantities listed above are required for proper assembly.  
Extra hardware pieces may be included.

# Step 1

Let's get started! Using a screwdriver, begin by attaching both Door Stoppers (G) to the Top Panel (1) using the 14 mm Screws (F). Then, screw the Cam Bolts (B) into the Top Panel (1).

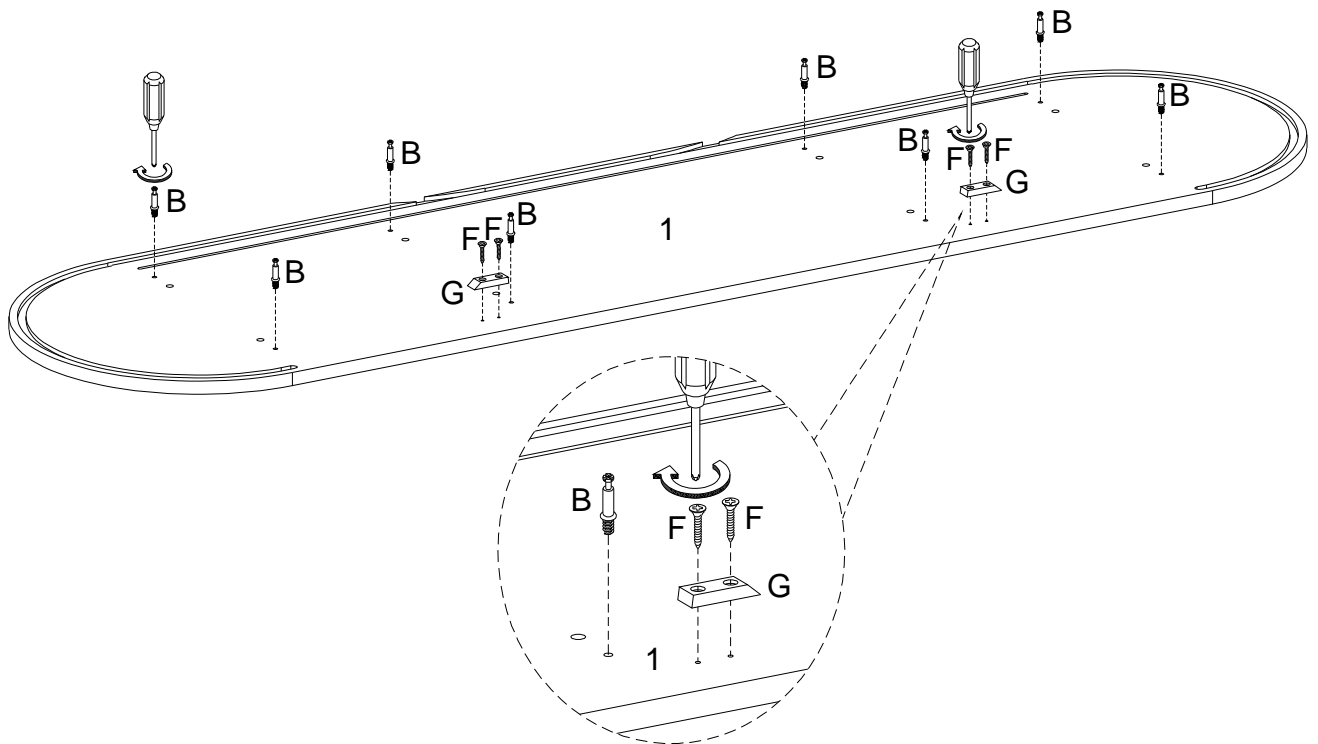

# Step 2

Insert Dowels (A) into the Right Panel (4), Right Vertical Dividing Panel (6), Left Vertical Dividing Panel (5), and the Left Panel (3).

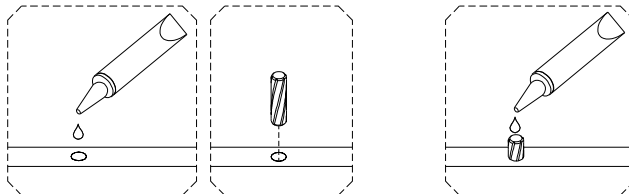
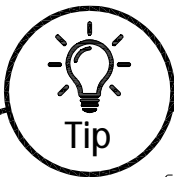
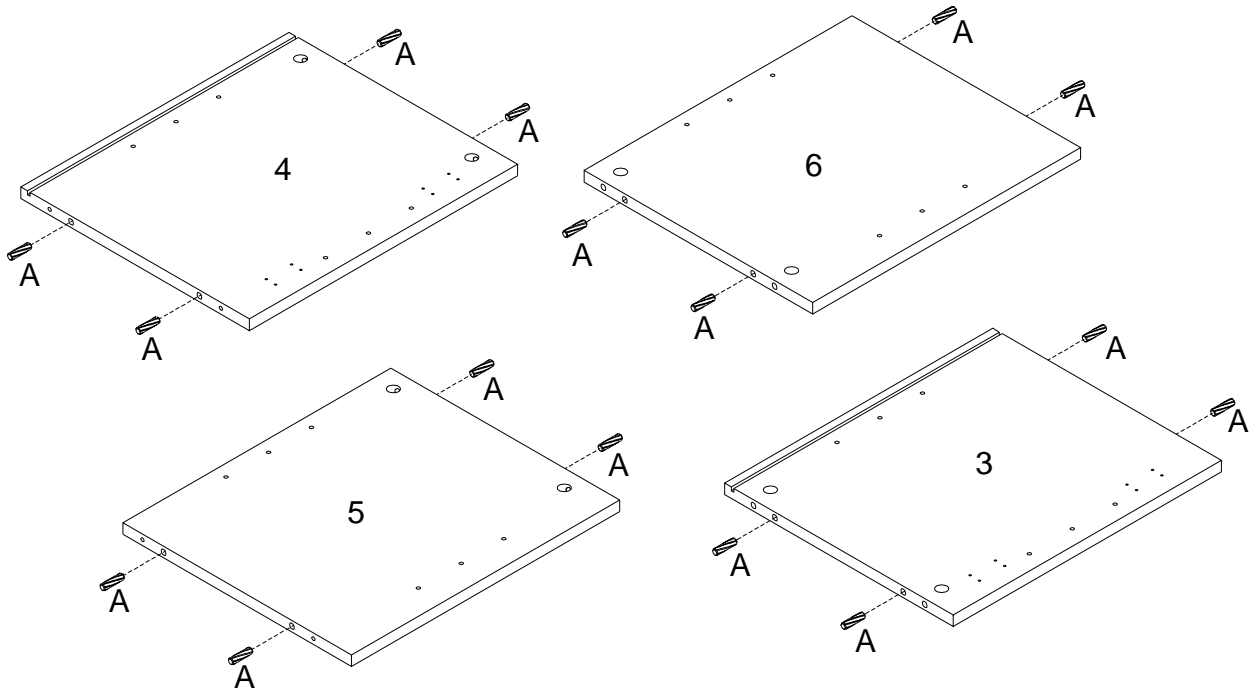

1: The provided glue is to secure wood dowels in place. When first inserting dowels, locate the appropriate hole for the dowel, place a small amount of glue in the hole and insert the dowel. Wipe away excess glue immediately.

2: In future assembly steps when dowels are necessary to attach assembly parts together, place a small amount of glue on the end of the dowel before attaching parts together. Wipe away excess glue immediately.

# Step 3

Insert Left Panel (3), Right Panel (4), Left Vertical Dividing Panel (5), and Right Vertical Dividing Panel (6) into the Top Panel (1). Secure with Cam Locks (C) and tighten with a screwdriver.

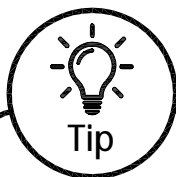
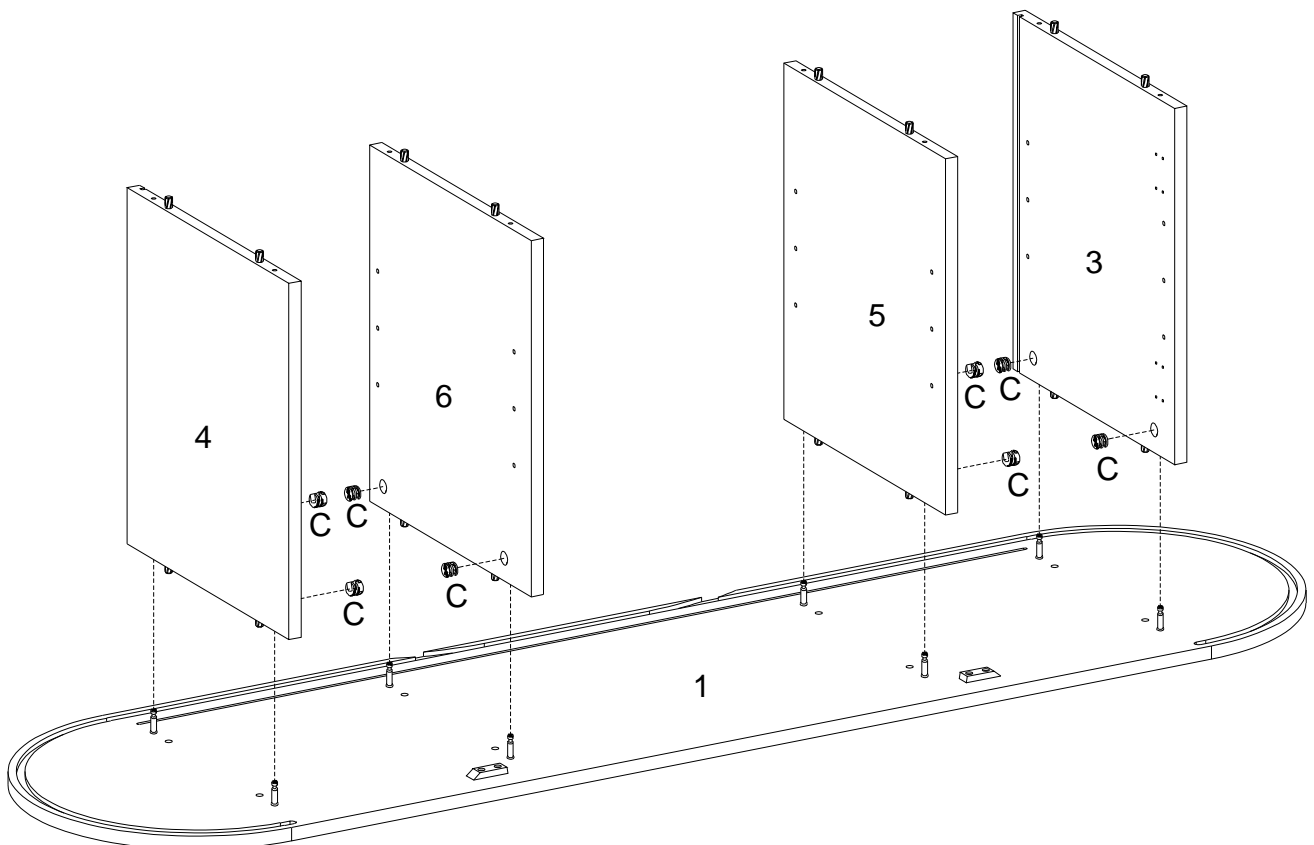

Tip

## Cam Locks

Cam Locks help securely join two pieces together.  
Follow these easy steps.

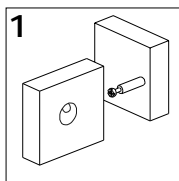

1: Insert Cam Bolt into bolt holes on the flat side. Don't over tighten!

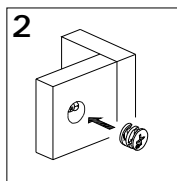

2: Fit the proper holes on the edge of the other part over the Cam Bolts. You should be able to see the cam bolts through the larger hole on the side.

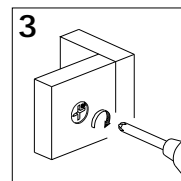

3: On the back of the Cam Lock will be a "C" shape. Insert the Cam Lock so the opening of the "C" fits over the Cam Bolt. Tighten with the screwdriver.



# Step 4

Slide the Back Panel (12) into place using the grooves.

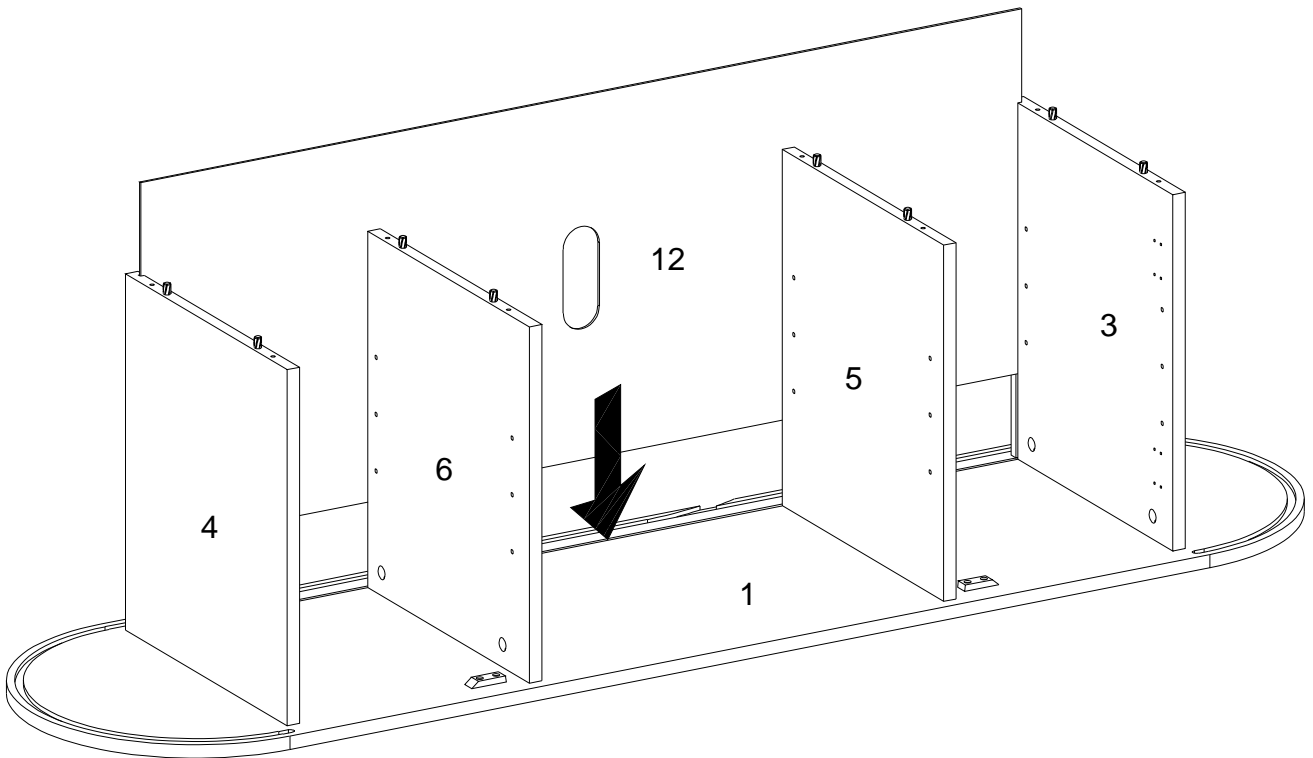

# Step 5

Attach the Bottom Panel (2) to the Left Panel (3), Right Panel (4), Left Vertical Dividing Panel (5), and Right Vertical Dividing Panel (6) using the 50mm Bolts (K) and Hex Key (L).

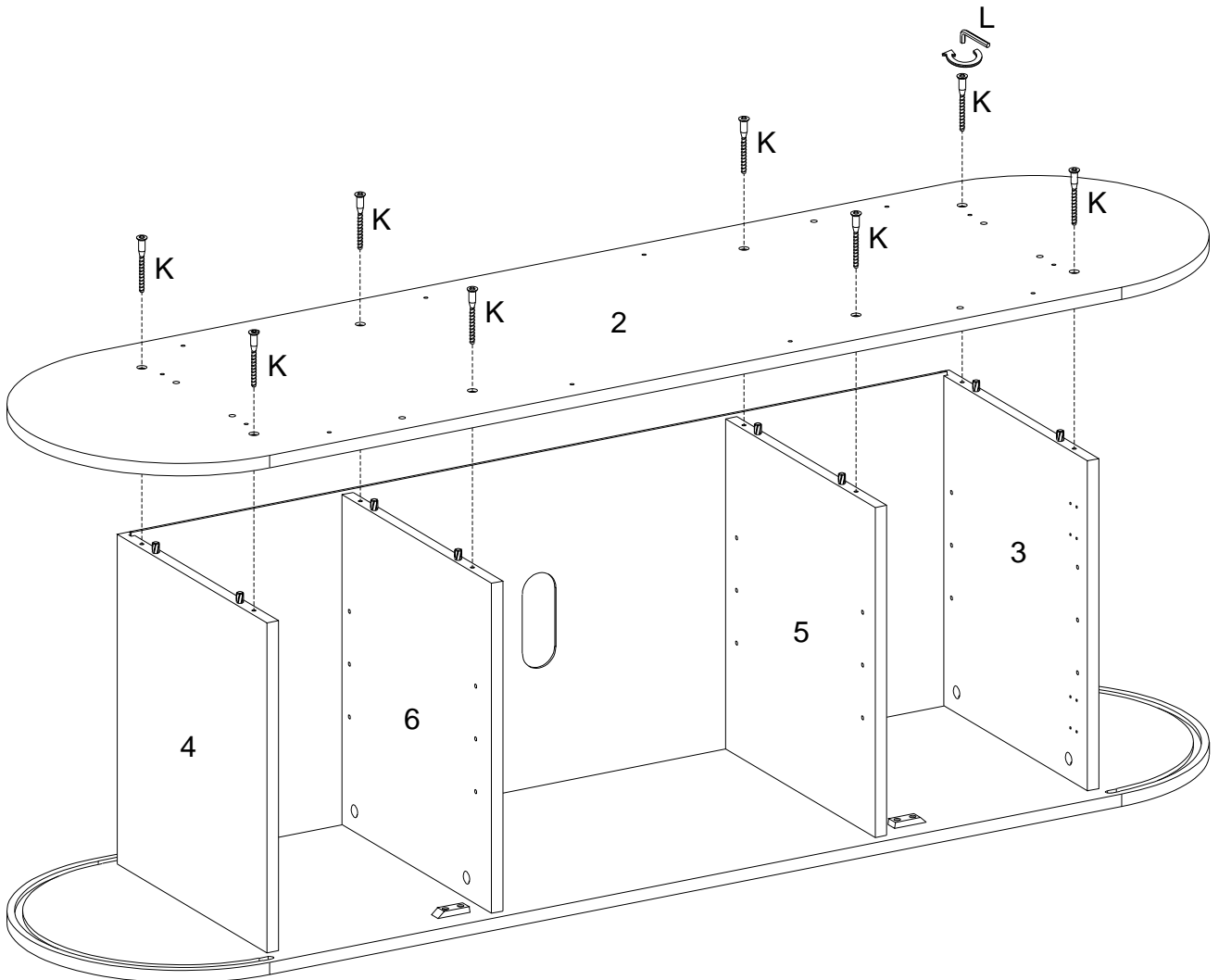

# Step 6

Using a screwdriver, attach the Cam Bolts (B) into the Bottom Panel (2).

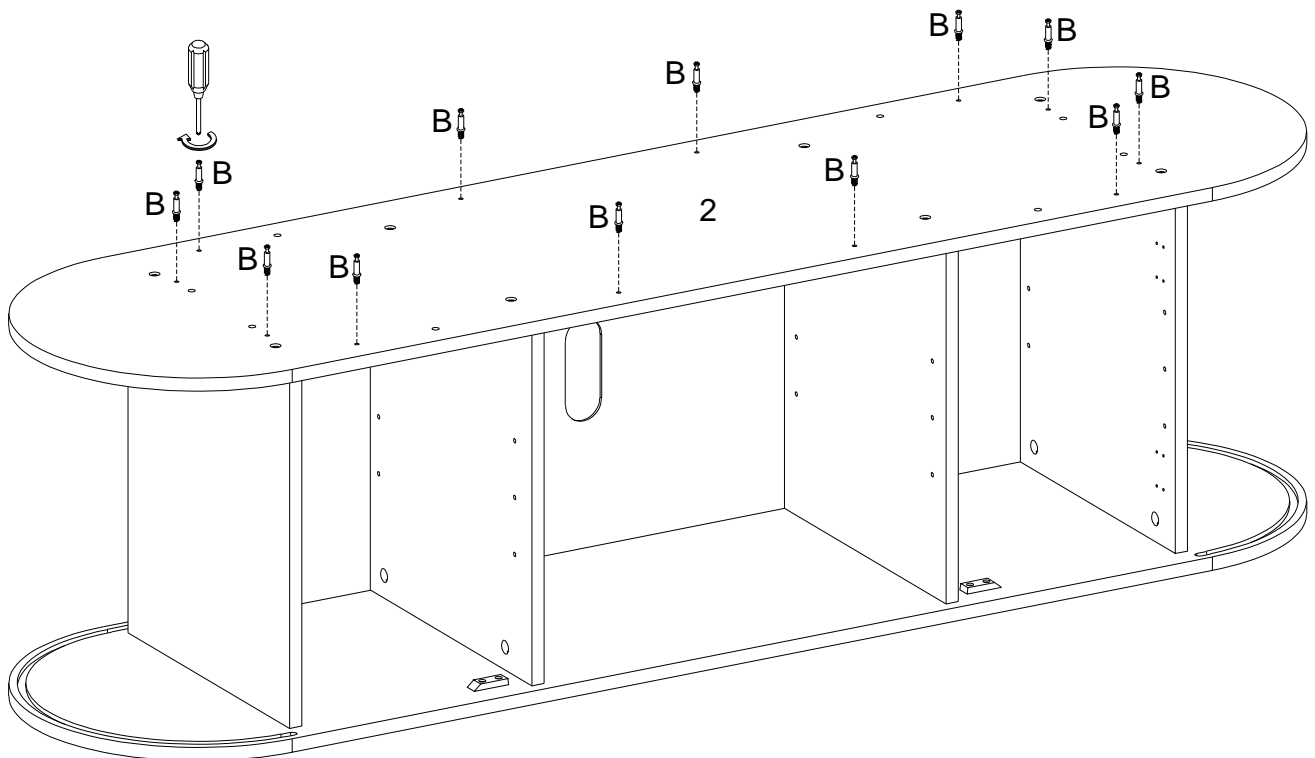

# Step 7

Insert Dowels (A) into the Leg Frame (13)

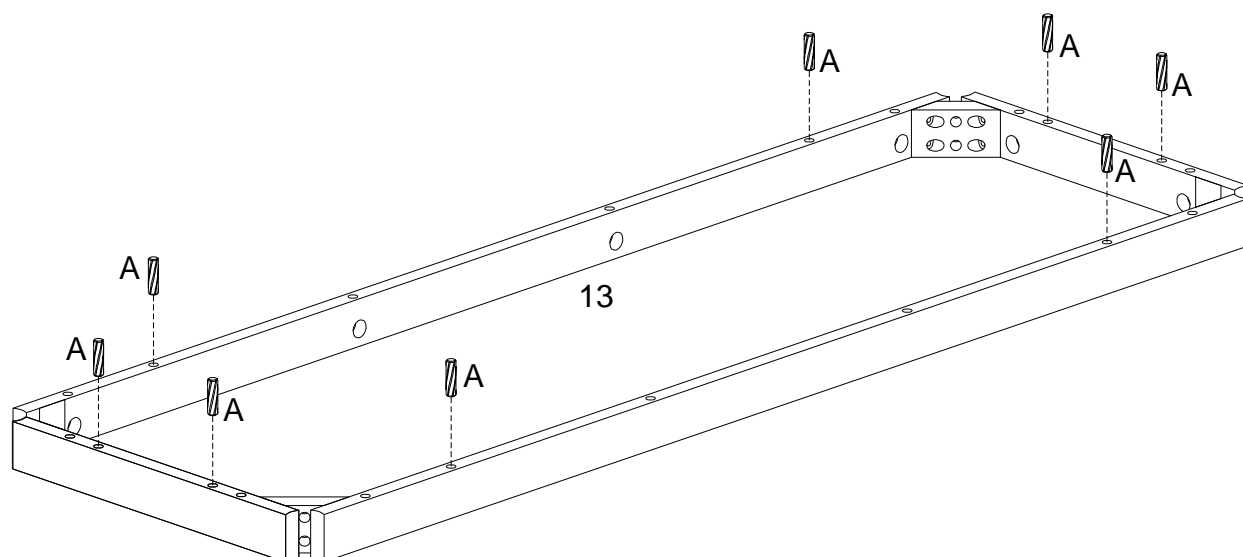

# Step 8

Attach the Leg Frame (13) to the Bottom Panel (2). Secure with Cam Locks (C).

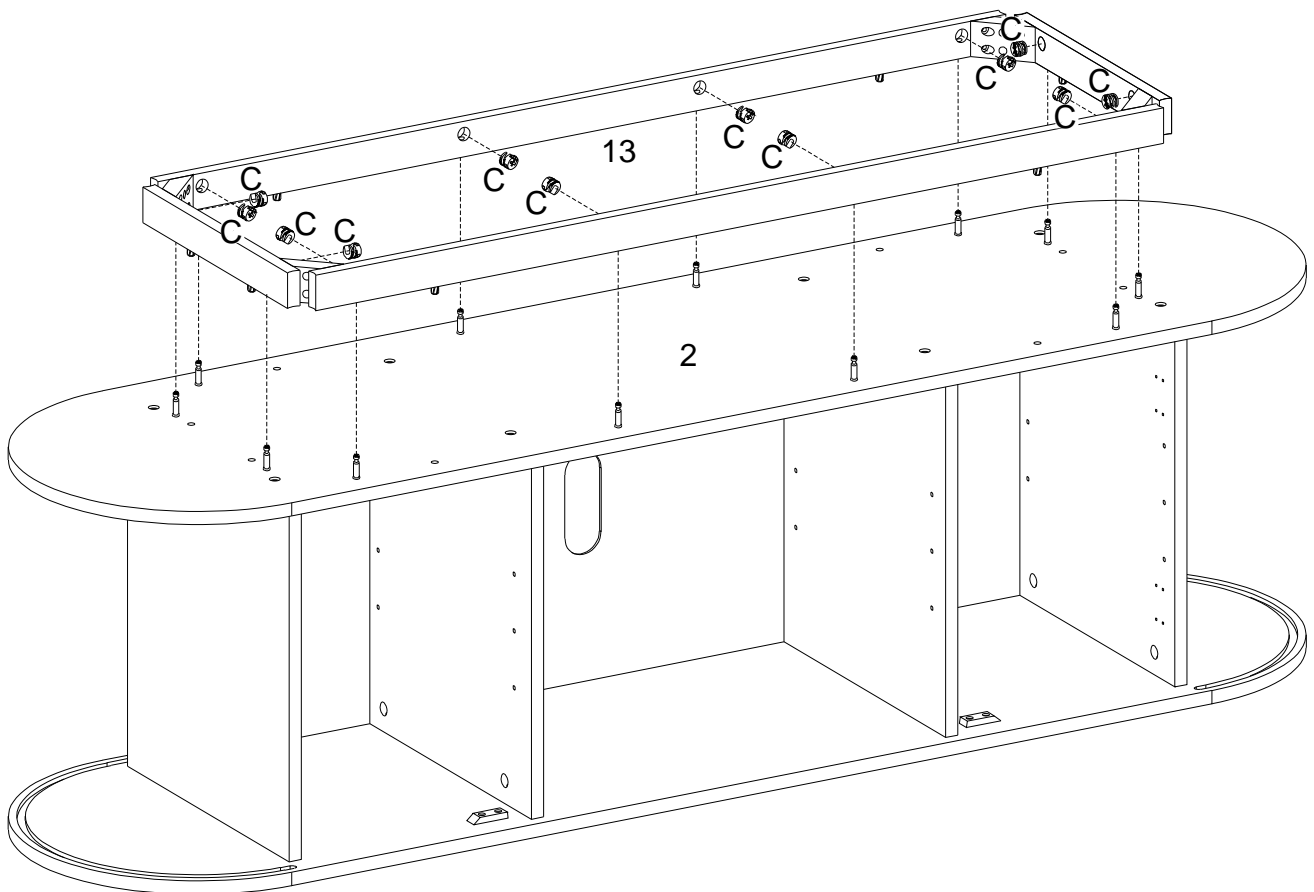

# Step 9

Attach the four Legs (14) to the Leg Frame (13) using the Flat Washer (S), Lock Washer (R), and the 50mm Bolts (Q).  
Tighten the Bolts (Q) with the Hex Key (L).

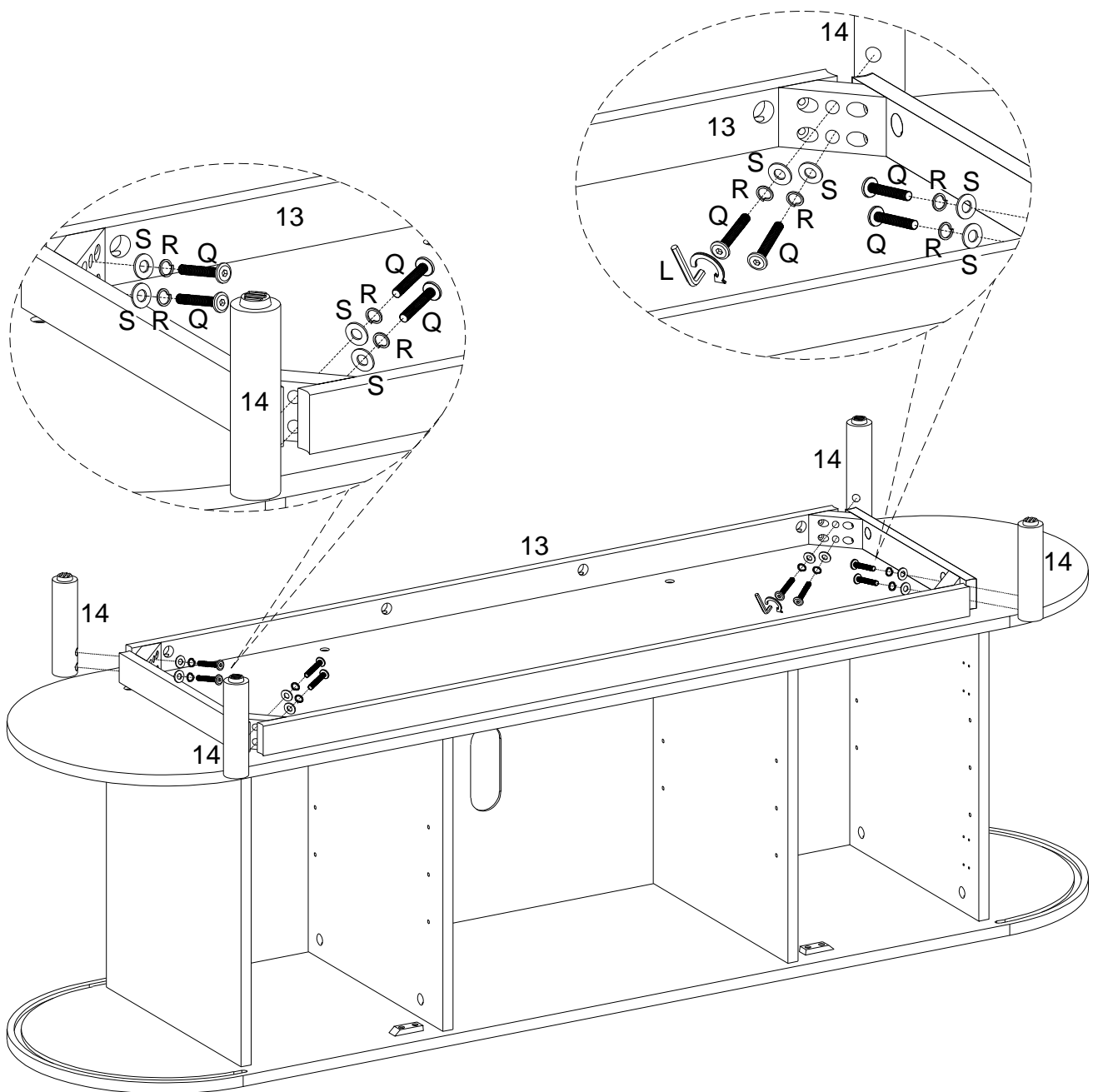

# Step 10

Place Stickers (D) over each Cam Lock (C) to ensure a clean finish.

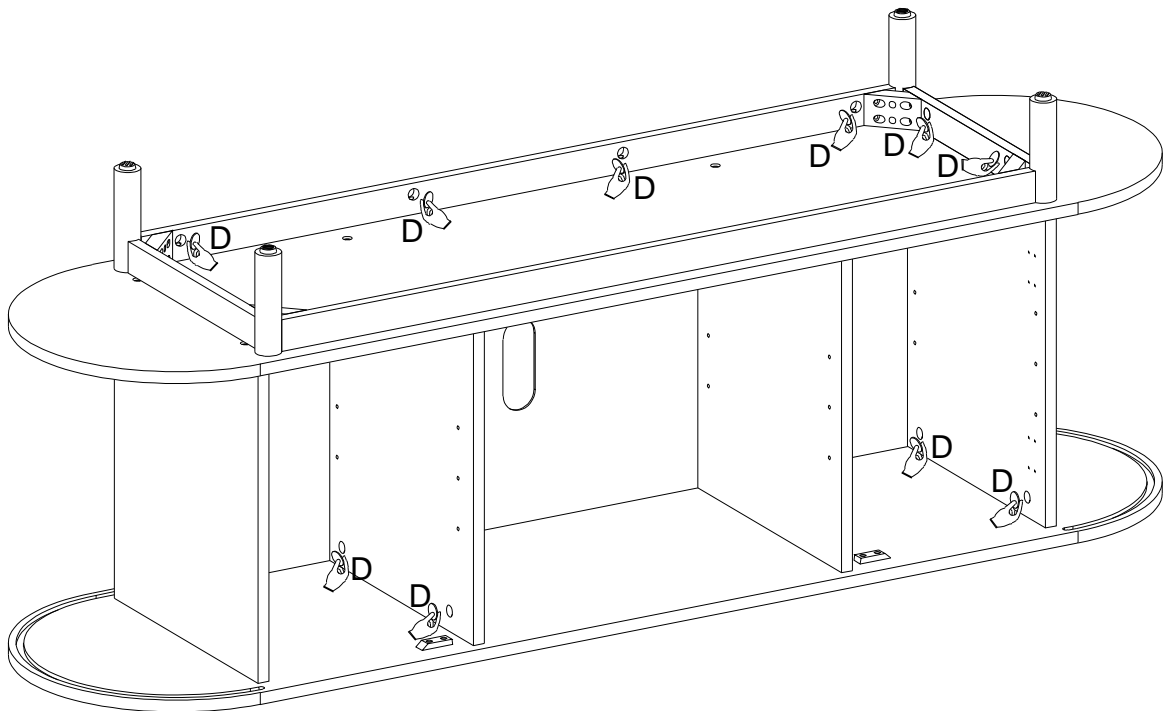

# Step 11

Evenly space the Plastic Wedges (N) between the Back Panel (12) and the frame. Secure the wedges into place using the 17 mm Screws (P).

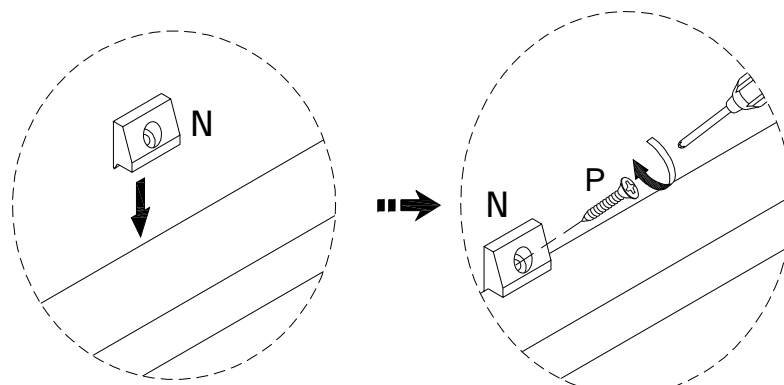
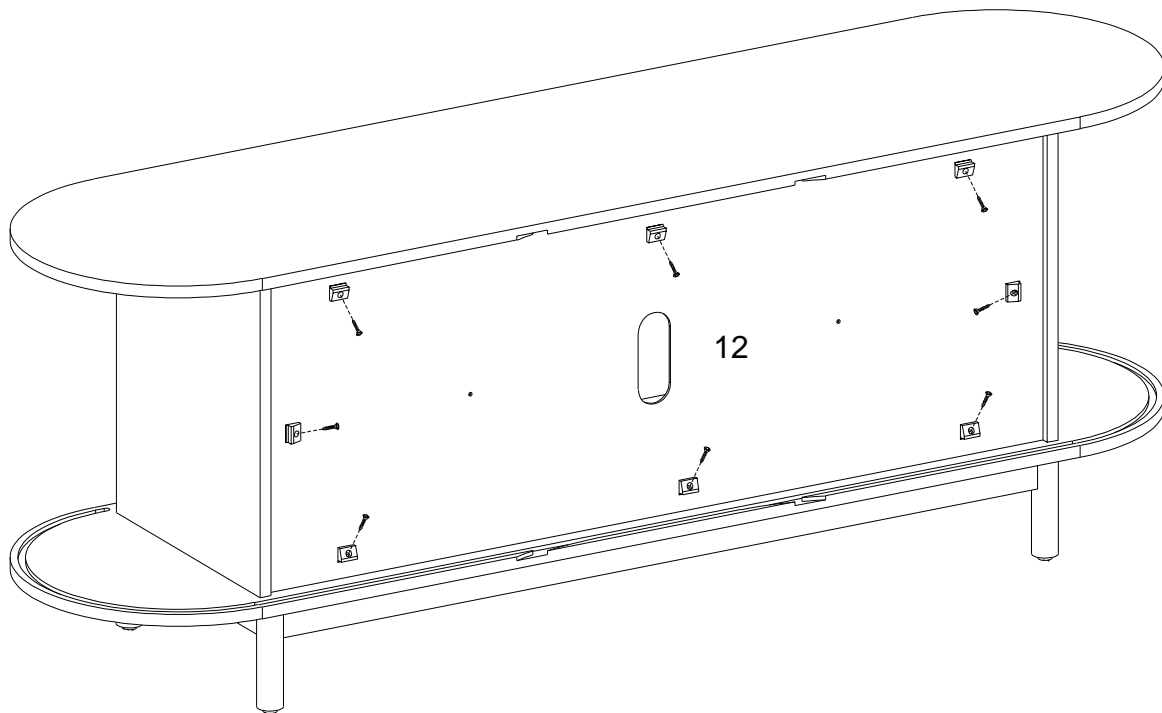



# Step 12

Using the pre-drilled holes, secure the Back Panel (12) to both the Right Vertical Dividing Panel (6) and the Left Vertical Dividing Panel (5) using the 15 mm Screws (T).

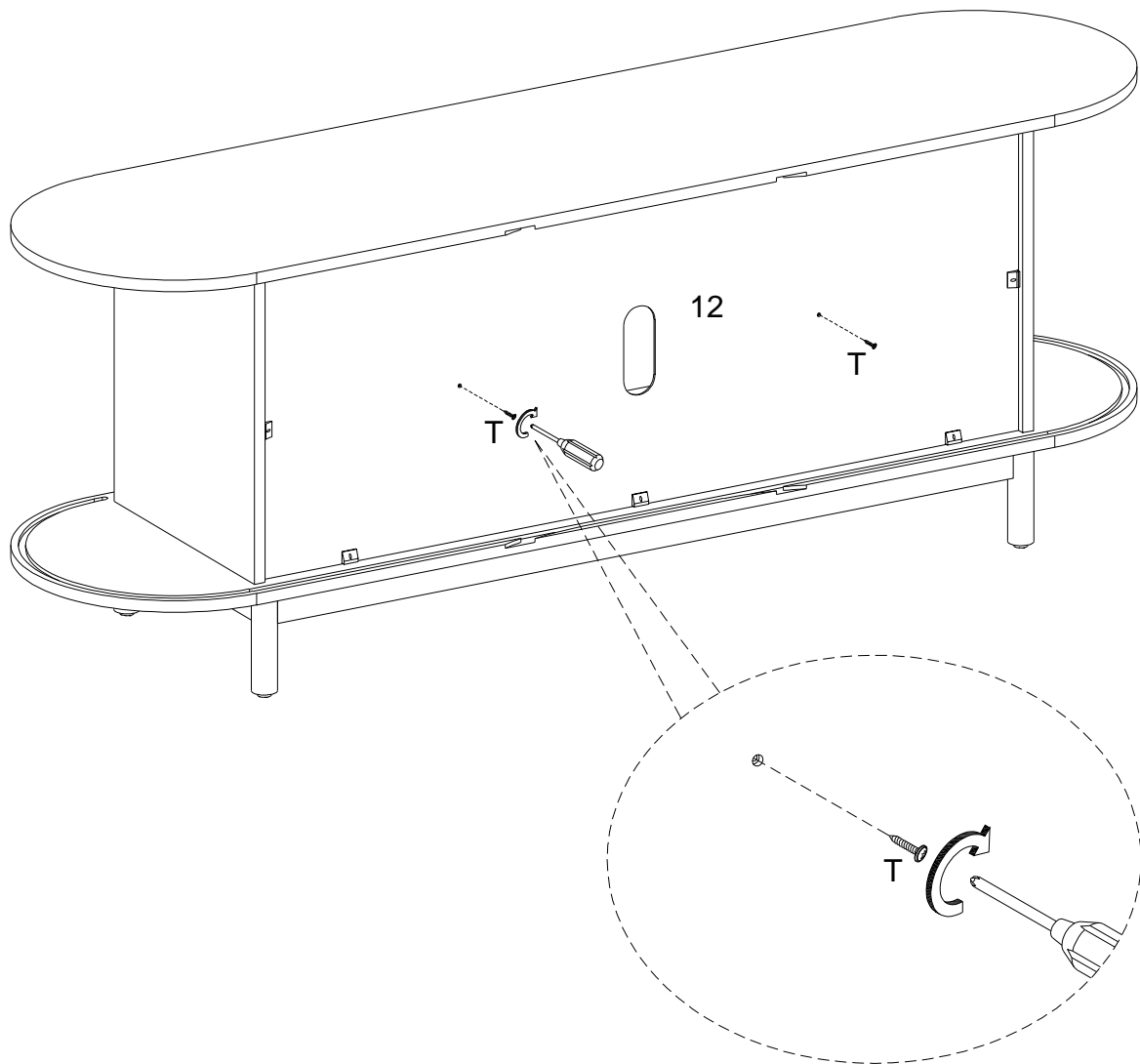

# Step 13

Insert the Shelf Support Pins (M) into the Left Panel (3), Right Panel (4), and Left Vertical Dividing Panel (5), and Right Vertical Dividing Panel (6). Then, slide the Adjustable Side Shelf (7) & Adjustable Middle Shelf (8) into place. Make sure the notches on the shelves fit onto the Shelf Support Pins (M).

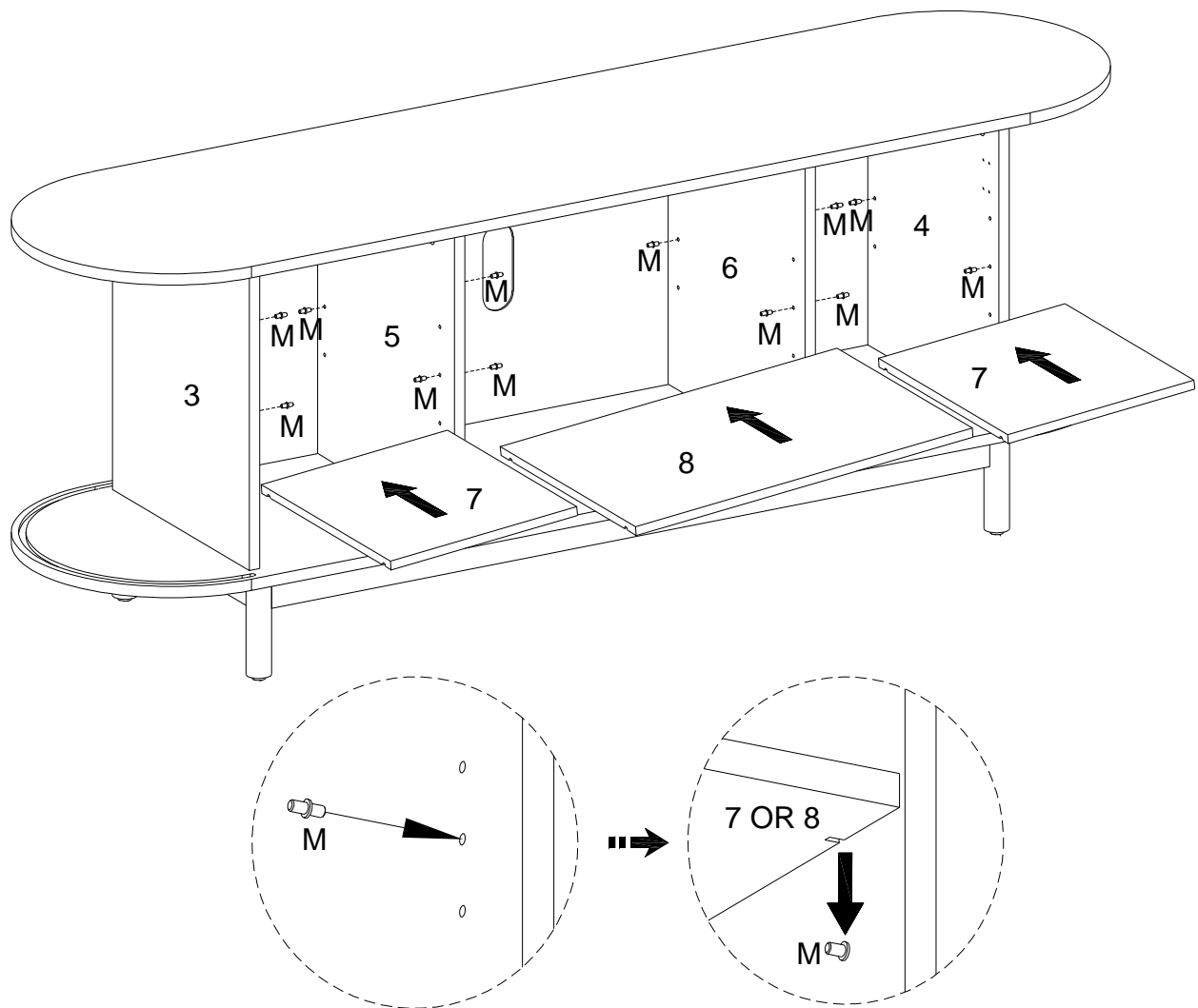

# Step 14

Attach the Handles (E) to the Left Door (10) & Right Door (11) using the 14 mm Screws (F). Then, attach the Hinges (H) to each door using the 14 mm Screws (J).

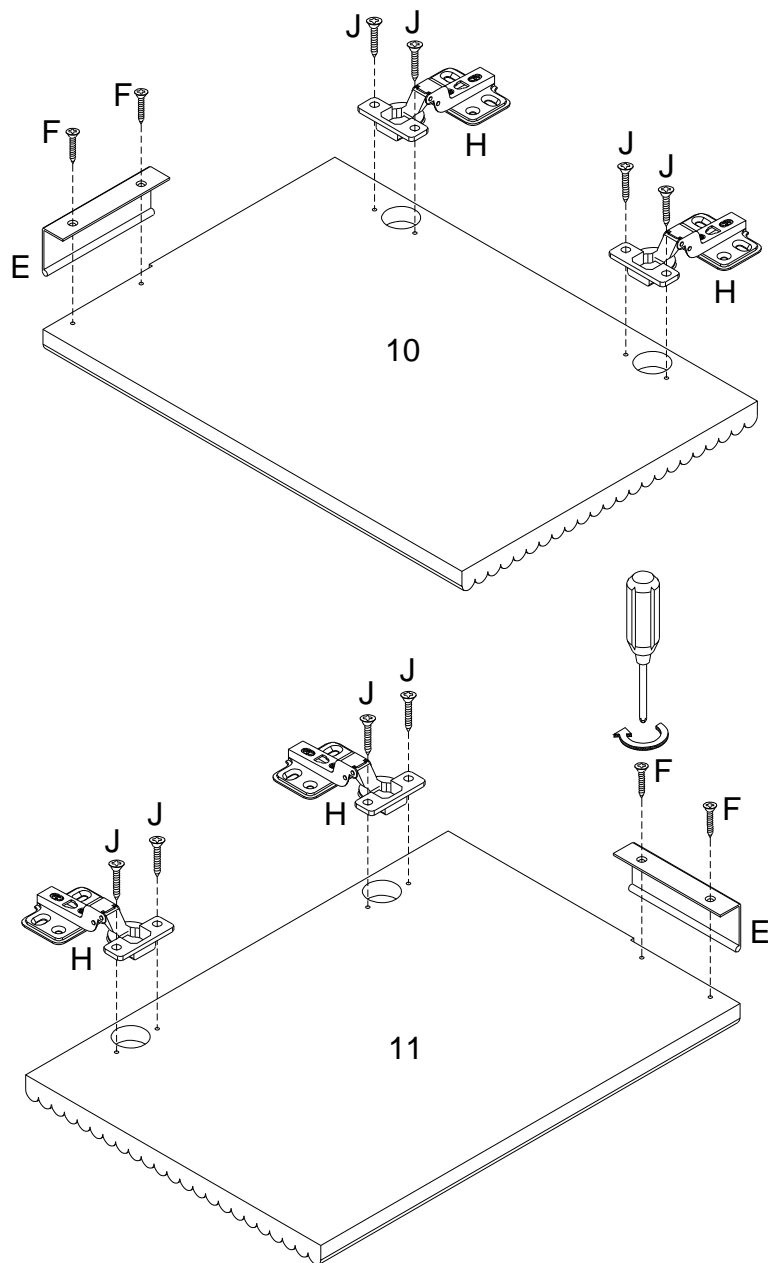

# Step 15

Using a screwdriver, attach the Left Door (10) to the Left Panel (3) using the 14 mm Screws (J).

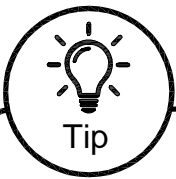
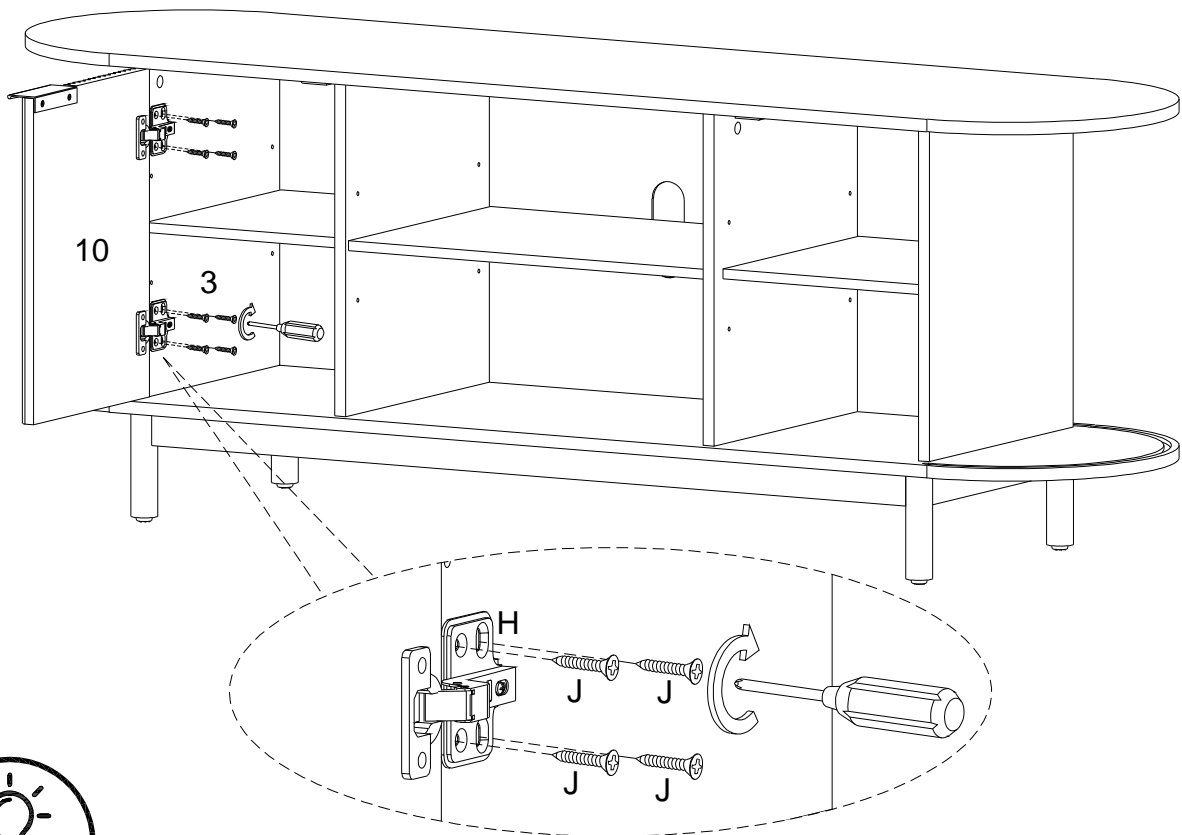

## Adjusting The Cabinet Doors

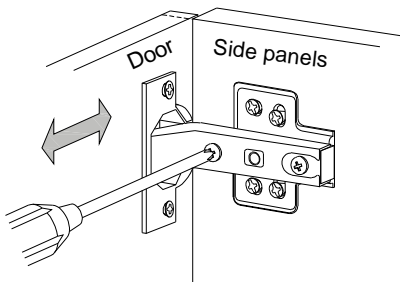

Adjust horizontal width with this screw.

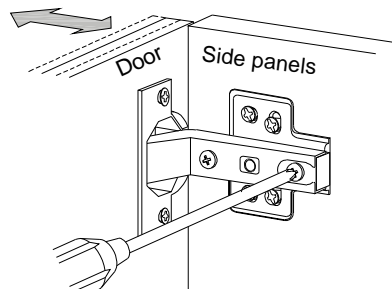

Adjust depth position by loosening the hinge arm mounting screw.

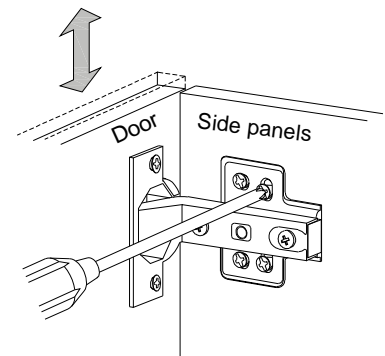

Adjust vertical height via the screws in the mounting plate.

# Step 16

Now, let's attach the Right Door (11) to the Right Panel (4) using the 14mm Screws (J).

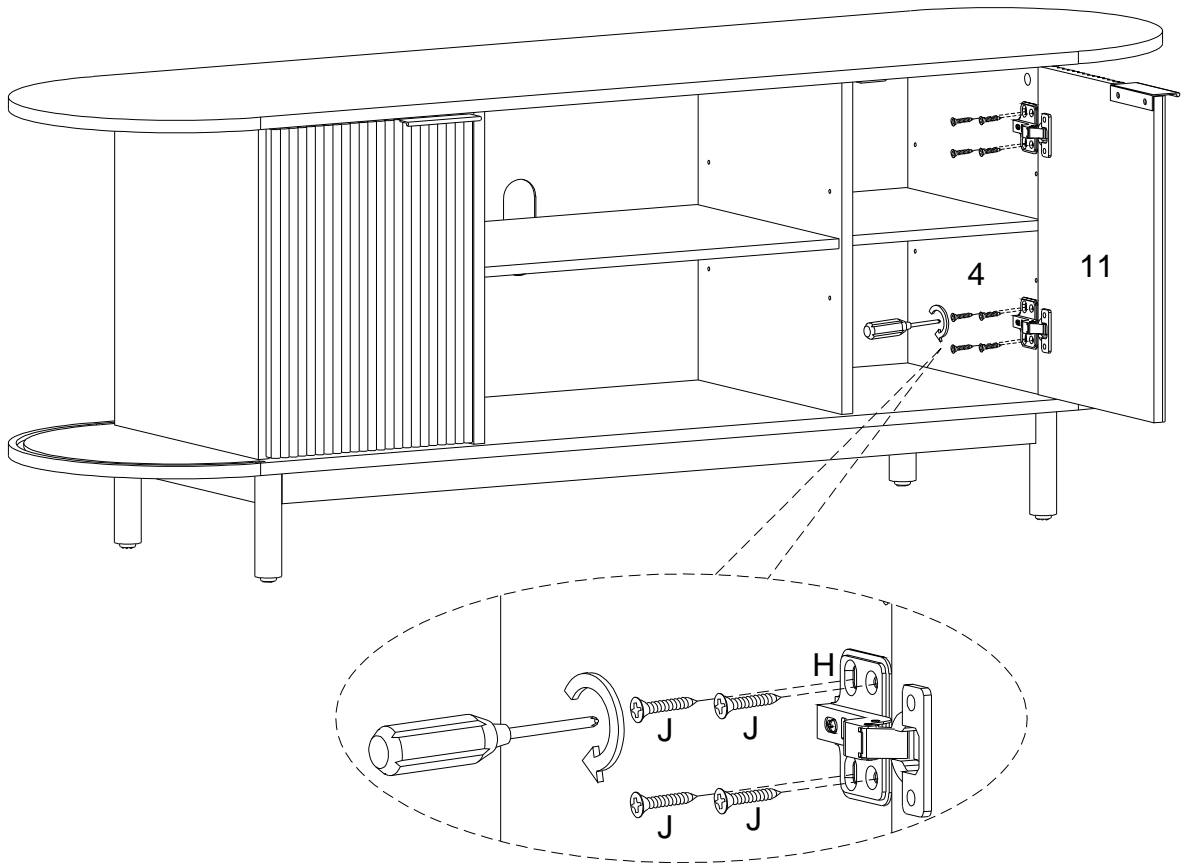

# Step 17

To ensure the drawers slide smoothly, rub the Wax (U) into the glides surrounding the Top Panel (1) and Bottom Panel (2).

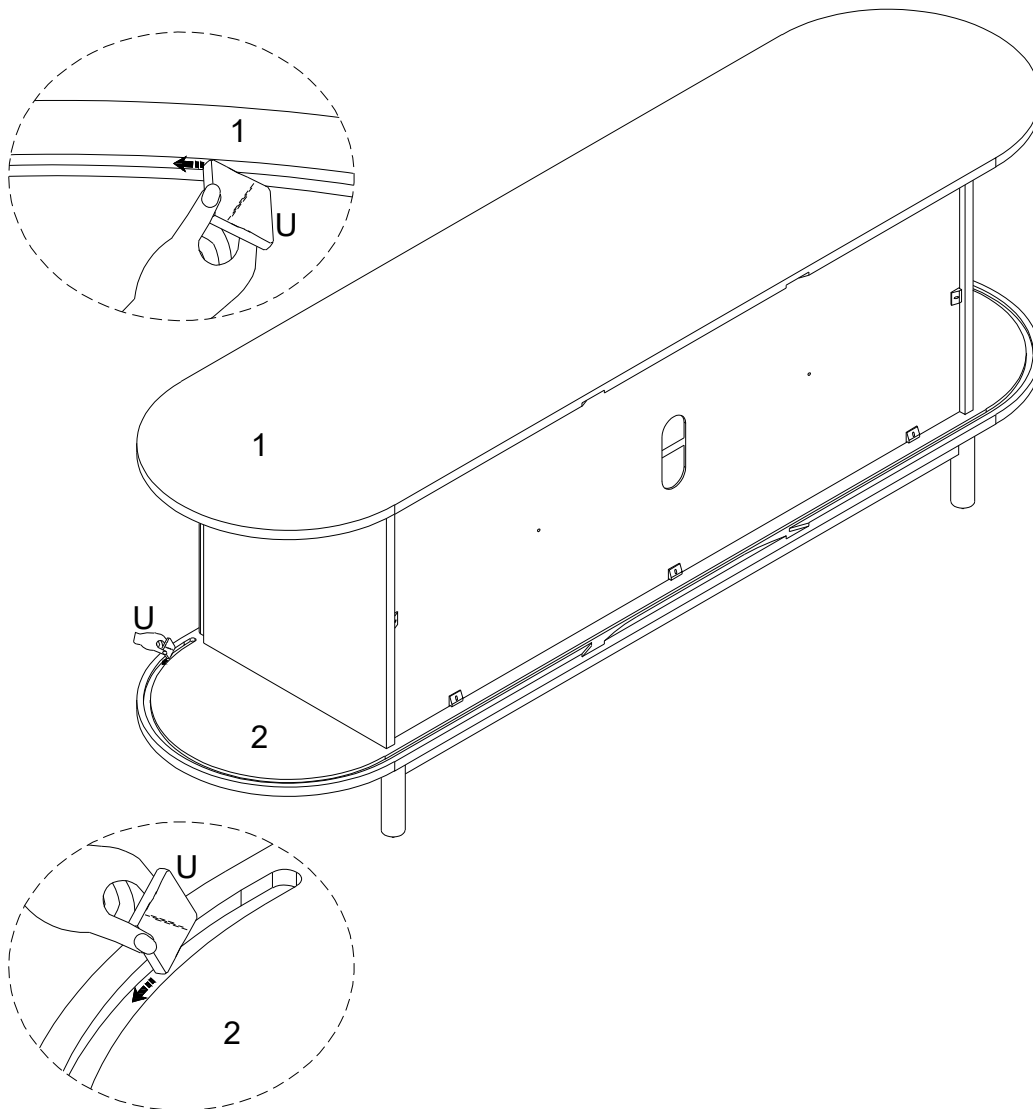

# Step 18

Insert one of the Sliding Doors (9) with the handle-side out into the left notch in the Top Panel (1) and Bottom Panel (2). Slide the door around until it meets the hinge-side of the Left Door (10).

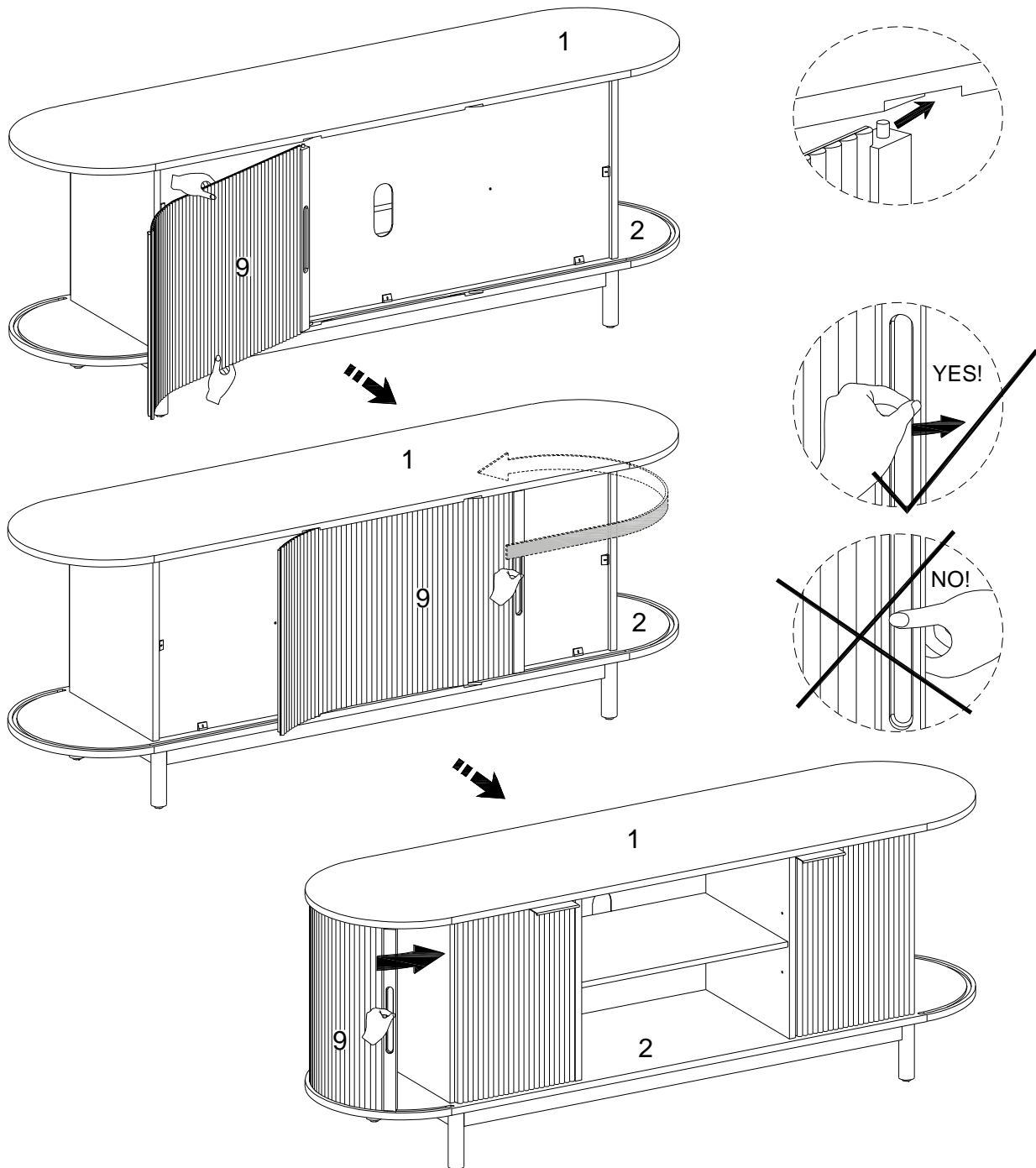

# Step 19

Now, repeat the process for the other side. Insert the other Sliding Door (9) handle-side out into the right notch in the Top Panel (1) and Bottom Panel (2). Slide the door around until it meets the hinge-side of the Right Door (11).

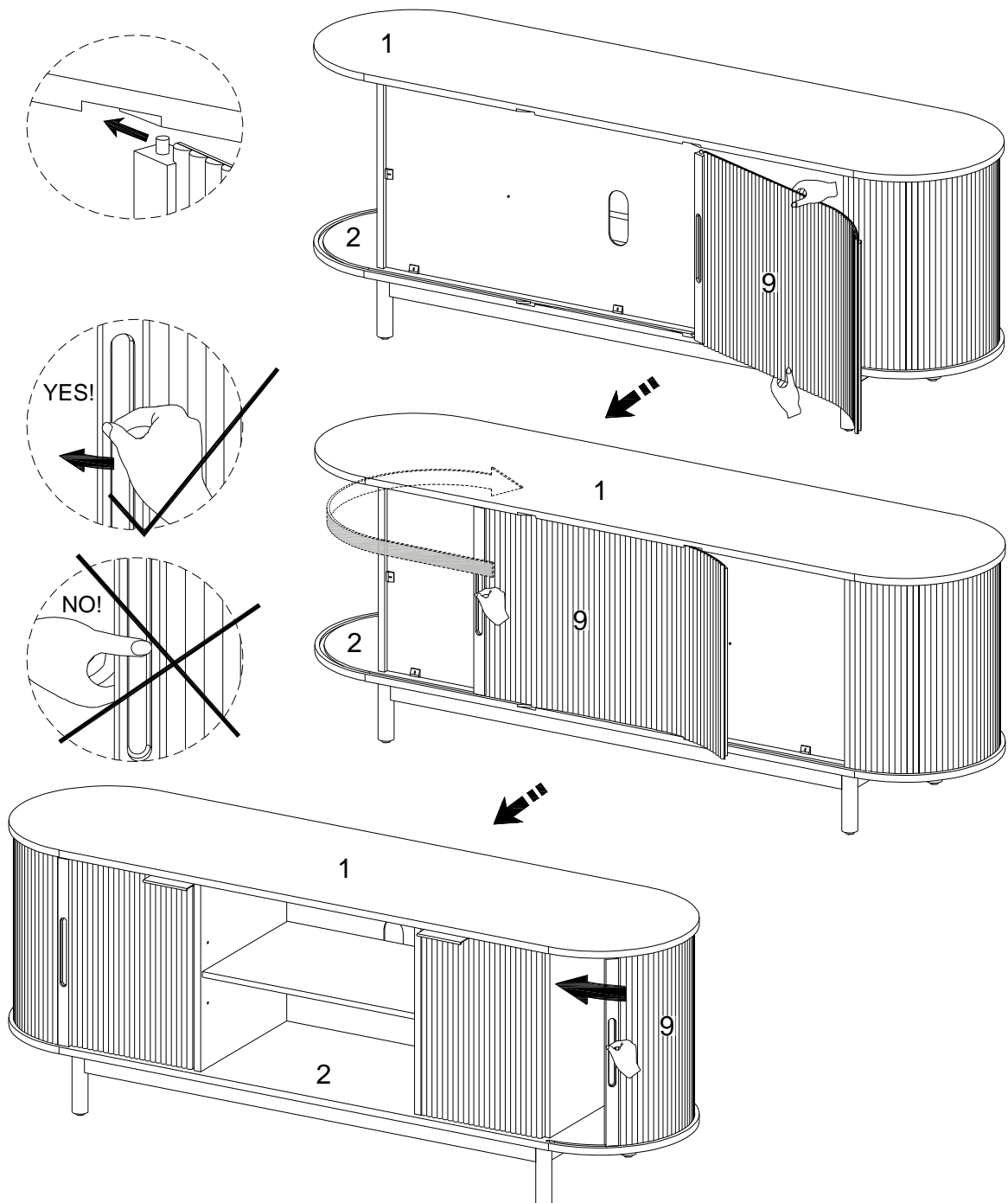



# Step 20

Use the adjustable feet to ensure a level surface.

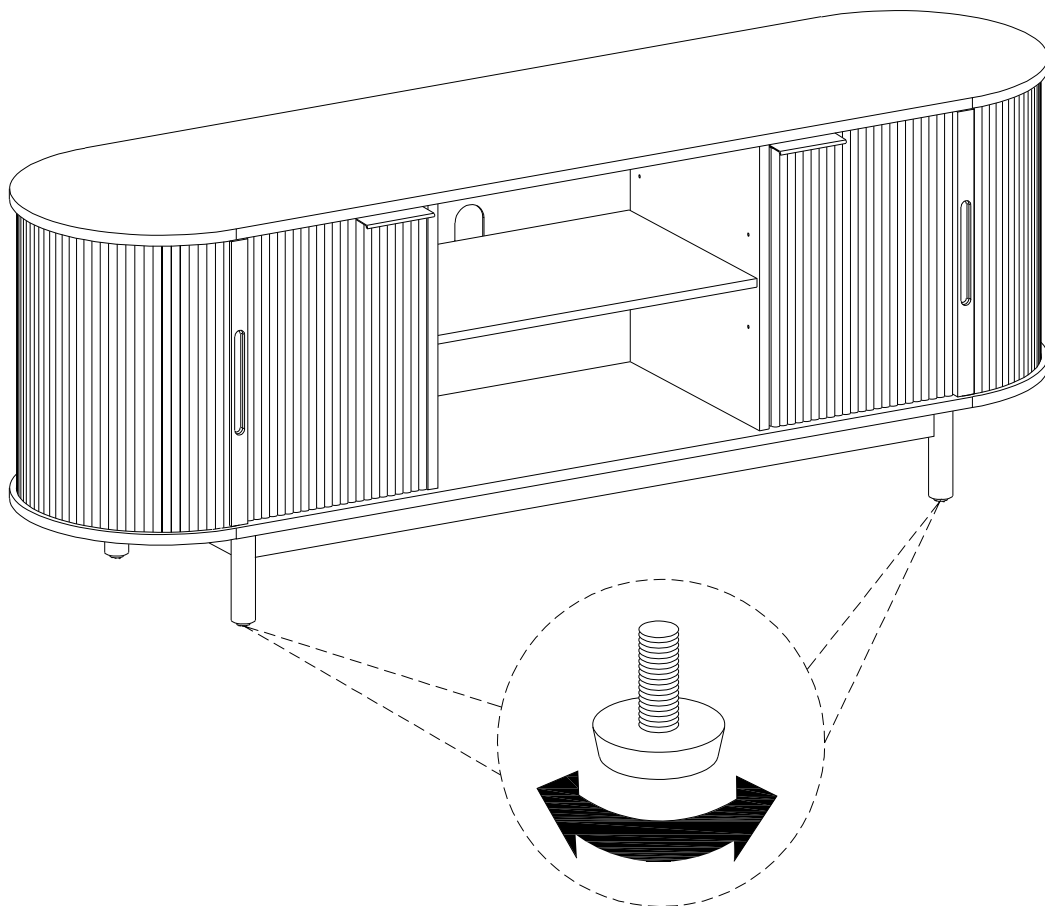

# Final Assembly

Congratulations, you did it! Enjoy your new TV Stand!

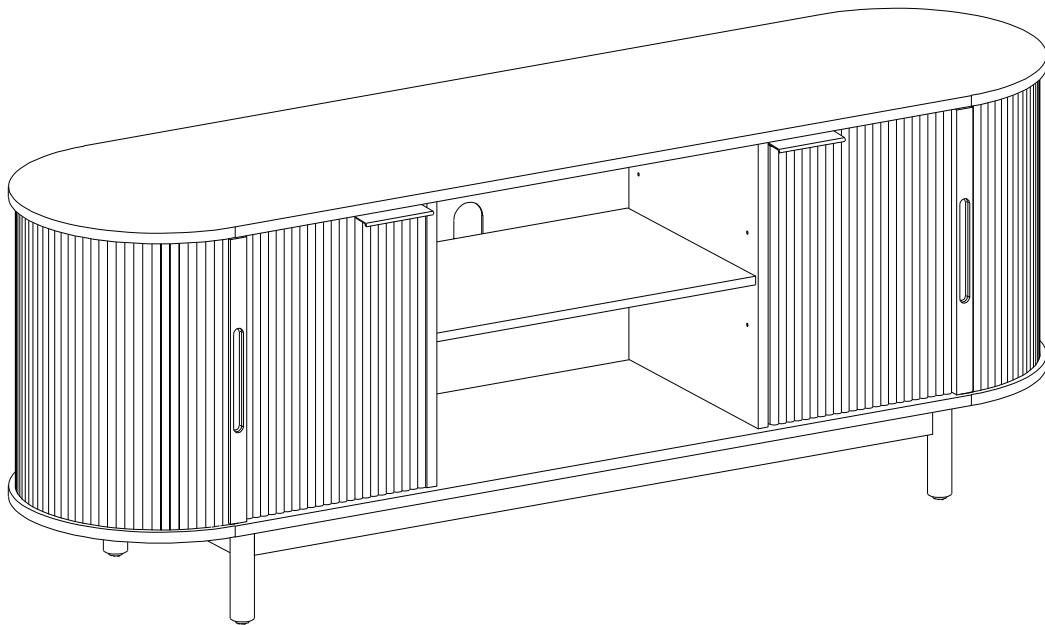

Congratulations on your new piece of furniture!

We would love to hear about it and see it.  
Please leave us a review or post a picture with  
[#mywalkerredisonhome](#)

# Assembling furniture can be tricky sometimes.

Our customer service team, located in Utah, is here for product information, help assembling a product, or for any other customer support issue

Call us at 801-433-3008

Email us at [service@walkeredison.com](mailto:service@walkeredison.com)

Visit our Customer Service website at [walkeredison.com/pages/customer-service](http://walkeredison.com/pages/customer-service)

We are available to help Monday -Thursday 8am-5pm, Friday 8am-3pm MST

For details on Assembly Videos, Assembly Instructions, Replacement Parts, and Customer service,  
**SCAN HERE**

