

PRODUCT SPECIFICATIONS

Outdoor Bi-Level Pedestal Fountain Non-Filtered Non-Refrigerated. Features shall include Heavy Duty Vandal Resistant, Laminar Flow, 300 Series Stainless. Furnished with Vandal Resistant bubbler. Mechanical Button activation. Product shall be Floor Mount/Freestanding, for Outdoor applications, serving 2 station(s).

Special Features:	Heavy Duty Vandal Resistant, Laminar Flow, 300 Series Stainless
Finish:	Black (BK), Blue (BLU), Evergreen (EVG), Gray (GRY)
Power:	No Electrical Required
Bubbler Style:	Vandal Resistant
Activation by:	Mechanical Button
Mounting Type:	Floor Mount/Freestanding
Chilling Capacity:	Non-refrigerated
Dimensions (L x W x H):	14" x 31" x 40-5/16"
Approx. Shipping Weight:	107 lbs.
Installation Location**:	Outdoor
No. of Stations Served:	2

**When used in non-temperature controlled environments, unit(s) must be adequately winterized and/or protected from extreme heat to prevent damage where climates dictate.

- Mechanically-Activated unit continues to supply water in event of service disruptions.
- Laminar flow provides clean fill with minimal splash.

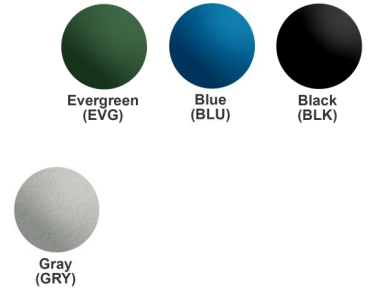

Included with Product: Outdoor Fountain Ships in one box.

A Century of Tradition and Quality. For more than 100 years, Elkay has been making innovative products and providing exceptional customer care. We take pride in offering plumbing products that make life easier, inspire change and leave the world a better place.



PRODUCT COMPLIANCE

- ADA & ICC A117.1
- ASME A112.19.3/CSA B45.4
- NSF/ANSI 61 (Q_s1) & 372 (lead free)
- NSF REG4



Complies with ADA & ICC A117.1 accessibility requirements when installed according to the requirements outlined in these standards. Installation may require additional components and/or construction features to be fully compliant. Consult the local Authority Having Jurisdiction if necessary.

[Installation Instructions \(PDF\) - 1000003683](#)

Warranty pertains to drinking water applications only. Non-drinking water applications are not covered under warranty.

[Warranty \(PDF\)](#)

PART: _____ QTY: _____

PROJECT: _____

CONTACT: _____

DATE: _____

NOTES: _____

APPROVAL: _____

Optional Accessories

In keeping with our policy of continuing product improvement, Elkay reserves the right to change product specifications without notice. Please visit elkay.com for the most current version of Elkay product specification sheets. This specification describes an Elkay product with design, quality, and functional benefits to the user. When making a comparison of other producers' offerings, be certain these features are not overlooked.

97890C

Accessory - Direct Bury Adaptor

[Spec Sheet \(PDF\)](#)



MOUNTING INSTRUCTIONS and PLUMBING CONNECTIONS

Provide solid, well-drained surface to mount pedestal fountain (concrete pad recommended) with adequate support (300lb. load minimum). (6) 3/8" minimum fasteners (not included) should be attached firmly to mounting surfaces in order to secure unit. (Refer to rough-in diagram)

Locate and install plumbing through ground as required.

NOTE: Unit is not furnished with service valve.

Position pedestal over plumbing and secure base to fasteners. Remove access panels and connect supply and water lines. Turn on water supply and check for leaks. Reassemble access panels to pedestal.

Trap and service not included.

OPERATING PRESSURES:
Supply water 20 – 105 psi maximum

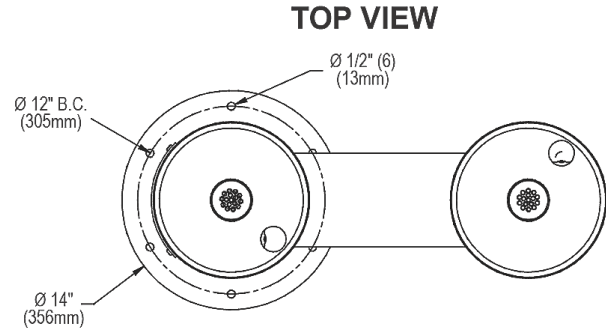

BACK VIEW

SIDE & FRONT VIEWS

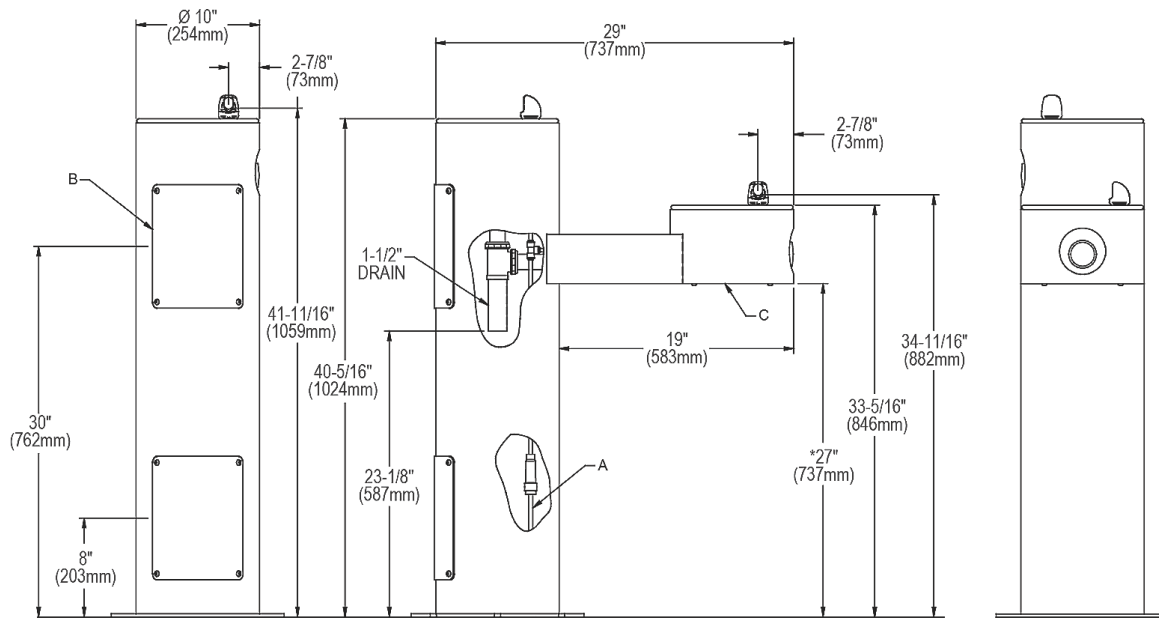

* ADA Requirement

- A = 3/8" O.D. Unplated copper tube connect shut off valve by others
- B = Access Panel (8" X 10")
- C = Removable bottom cover

In keeping with our policy of continuing product improvement, Elkay reserves the right to change product specifications without notice. Please visit elkay.com for the most current version of Elkay product specification sheets. This specification describes an Elkay product with design, quality, and functional benefits to the user. When making a comparison of other producers' offerings, be certain these features are not overlooked.