

Installation Guide

Wall-Mount Valve

K-11830, K-11831, K-11842, K-11843

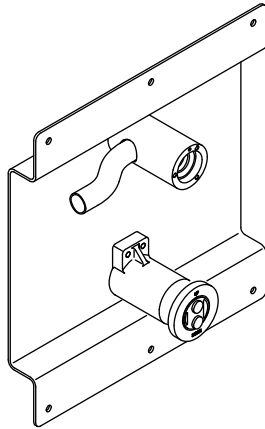

M product numbers are for Mexico (i.e. K-12345**M**)
Los números de productos seguidos de
M corresponden a México (Ej.
K-12345**M**)
Français, page "Français-1"
Español, página "Español-1"

THE BOLD LOOK
OF **KOHLER**®

1124216-2-C

Tools and Materials



Adjustable
Wrench



Sealant Tape

Plus:

- Wire Fasteners
- Woodworking Tools
- Pipe Fitting Tools
- Wood Screws
- 2x4s

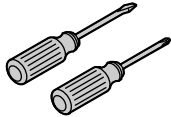

Assorted
Screwdrivers



Hex Wrench

Before You Begin

NOTE: Follow the installation dimensions precisely as there is no deep rough-in kit available for this product.

NOTE: Unless otherwise indicated, the illustrations in the document show installation with the water supply on the left. The valve may be flipped to accommodate a water supply on the right.

- Observe all local plumbing and building codes.
- Turn off the water supply.
- Inspect the supply tubing for damage. Replace as necessary.
- Site preparation and wall finishing may require additional tools and materials.

Drop-In Sinks

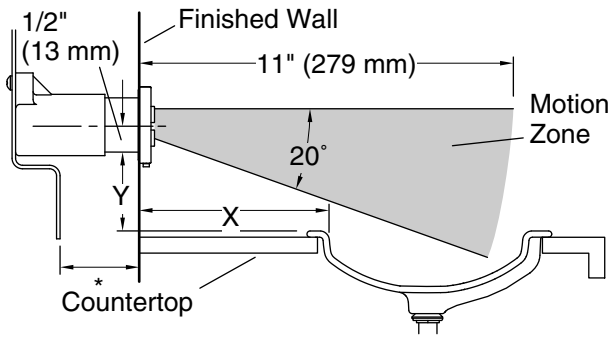

Under-Mount Sinks

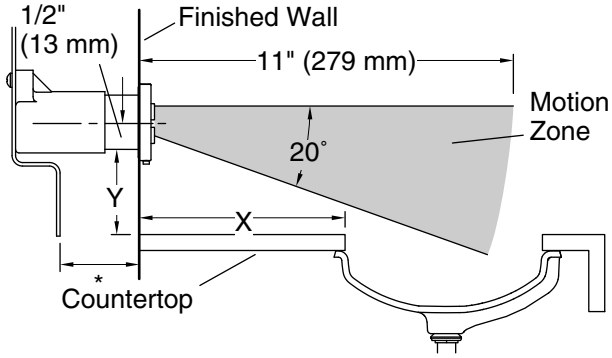

Above-Counter Sinks

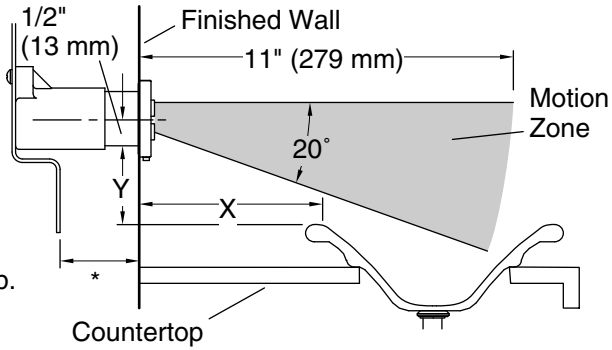

Important:
Measure "Y"
from the sink rim,
not the countertop.

* Consult the specification sheet for the spout that will be paired with this valve for specific installation dimensions.

1. Determine the Sensor Location

Determine the Sensor Location (cont.)

IMPORTANT! It is critical for proper operation that the sensor be installed with the motion zone clear of any obstructions, including the edge of the countertop or the bathroom sink.

- Measure the distance (**X**) from the finished wall to the inside edge of the countertop or bathroom sink.
- Determine the sensor height (**Y**) using the chart below. If you cannot determine Y from the chart, use the formula $.5'' + X(0.364)$ to determine (**Y**).

If dimension X is:	Then the sensor height (Y) is:
1" (25 mm)	7/8" (48 mm)
2" (51 mm)	1-1/4" (32 mm)
3" (76 mm)	1-9/16" (40 mm)
4" (102 mm)	2" (51 mm)
5" (127 mm)	2-3/8" (60 mm)
6" (151 mm)	2-9/16" (65 mm)
7" (179 mm)	3" (76 mm)
8" (203 mm)	3-7/16" (87 mm)
9" (229 mm)	3-3/4" (95 mm)

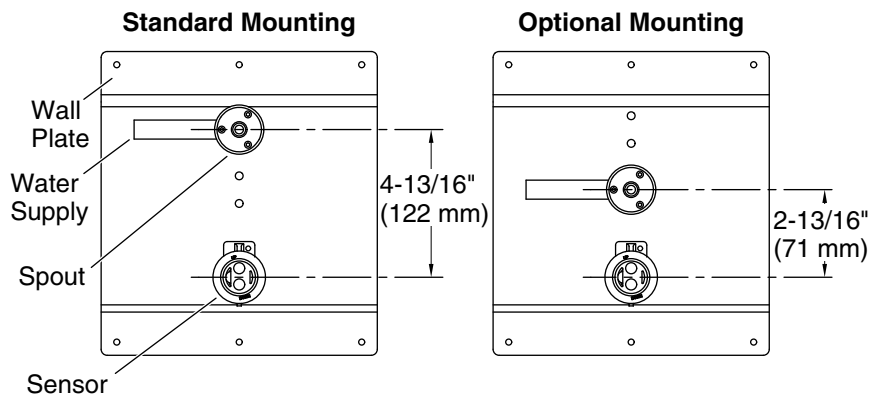

Standard Mounting	K-T11836, K-T11837, K-T11838, K-T11839, K-T11840, K-T11841
Optional Mounting	K-T11837, K-T11838

2. Determine the Spout Location

NOTE: Before installation, consult the specification sheet for the faucet to determine the correct wall rough-in for your installation.

NOTE: For optimal faucet performance, check the size of your spout to determine the best location above the sensor.

- **For Standard Mounting:** position the spout with one of the two upper hole locations on the wall plate.
- **For Optional Mounting:** position the spout with the bottom hole location on the wall plate.

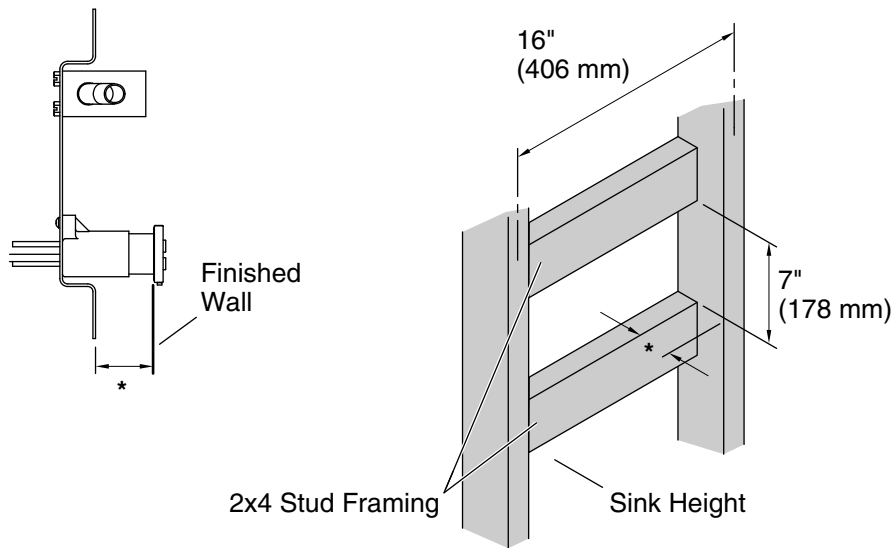

* Consult the faucet specification sheet for specific installation dimensions.

3. Prepare the Site

IMPORTANT! The valve requires special framing and support considerations. Consult the specification sheet for the faucet that will be installed with your valve for specific dimensions.

NOTE: Mount the valve with the sensor at the height determined in the "Determine the Sensor Location" section.

NOTE: A suggested framing example is shown. Each installation may have different framing requirements than those shown.

- Construct the framing for your installation.
- If a thermostatic mixing valve will be included with your installation, install the valve now following the directions provided with the valve.

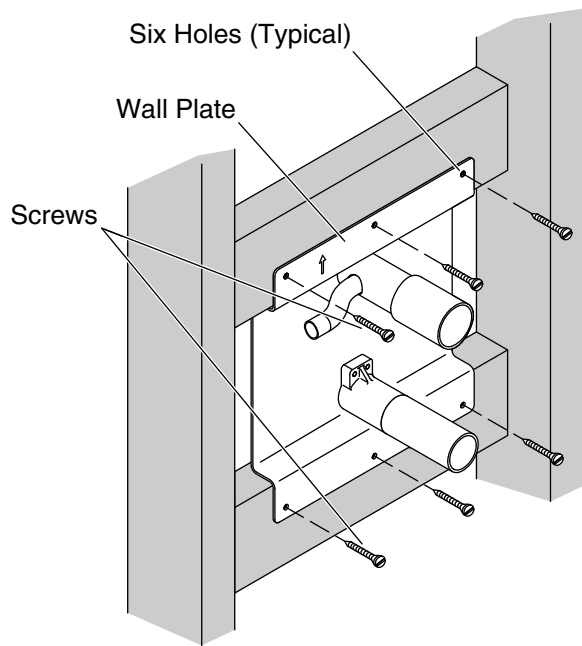

4. Secure the Wall Plate

IMPORTANT! Make sure the location of the valve is correct before securing it in place. The centerline of the drain and faucet should be in line with each other.

- Secure the wall plate to the studs using six wood screws (not provided).

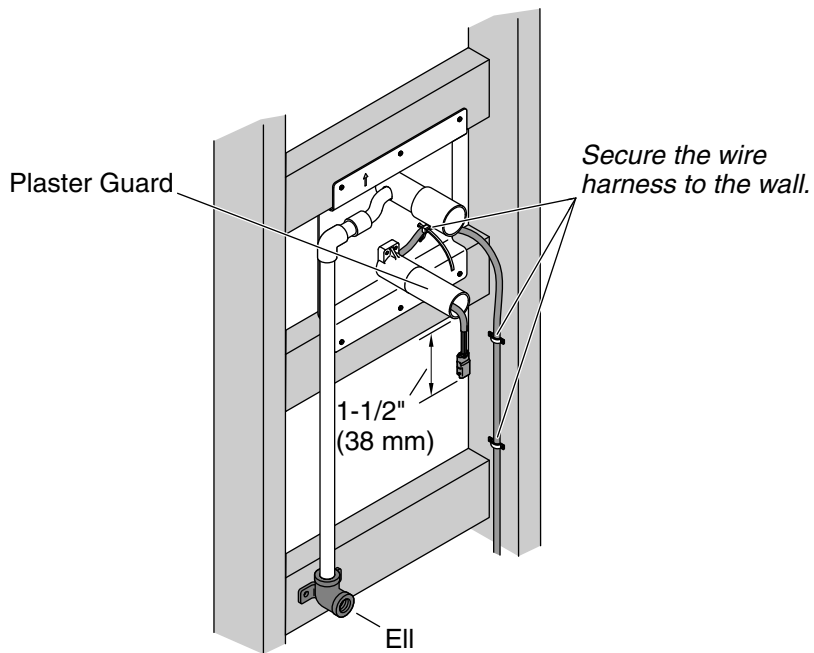

5. Install the Supplies

NOTE: The diameter of the faucet hole cutout is 1-3/4" (44 mm).
The diameter of the sensor hole cutout is 1-3/8" (35 mm).

NOTE: The diameter of the supply inlet opening is determined by the ell diameter.

- Install a 1/2" supply pipe to the valve assembly.
- At the point where the supply will exit the wall, install a drop ear ell flush or slightly behind the finished wall.
- Feed the sensor wire through the sensor mount and plaster guard, leaving 1-1/2" (38 mm) minimum of exposed wire protruding.
- Secure the sensor wire harness to the wall.
- Run the sensor wire through the tube or opening to the control box mounting location.
- Temporarily connect the water supply to the supply ell.
- Turn on the water.

Install the Supplies (cont.)

- Check the system for leaks.
- Turn off the water.
- Install the finished wall.

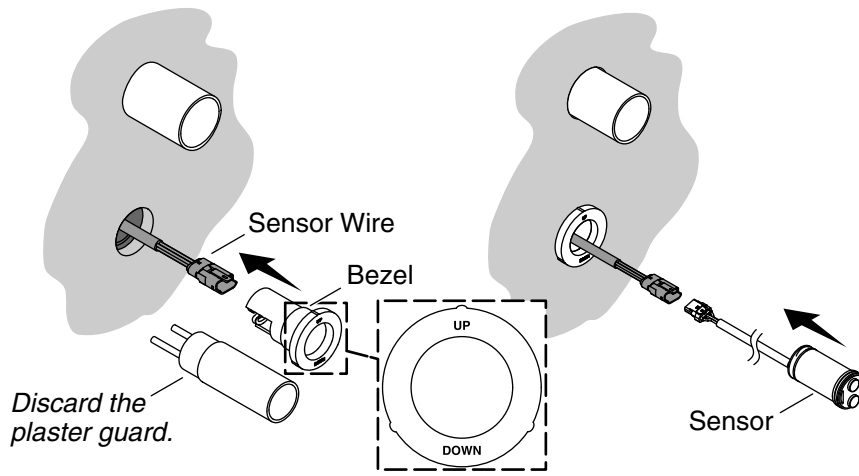

6. Install the Sensor

Install the Bezel

- Loosen the screws in the plaster guard.
- Remove the plaster guard and discard.
- Feed the sensor wire through the back of the bezel.
- Position the bezel over the screw heads and turn 1/8 turn counterclockwise.
- Confirm that the "UP" label is at the top.
- Tighten the screws.

Connect the Sensor

- Connect the sensor to the wire harness and feed the wire into the wall.
- Position the sensor in front of the bezel with the wire on the back of the sensor to the right.
- Push the sensor into place.

Ø 1/2" (13 mm)
Hole

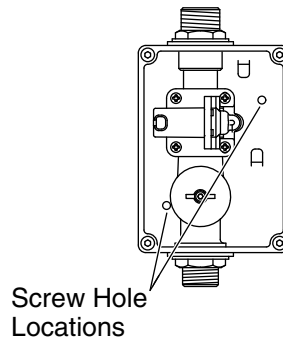
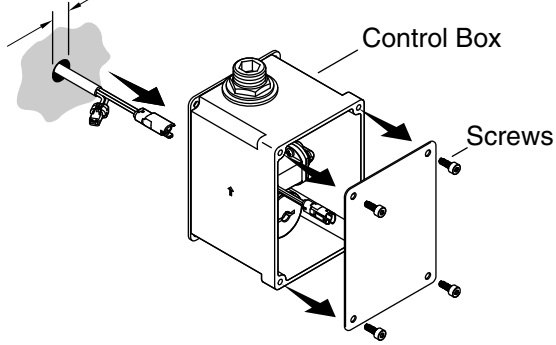

7. Install the Control Box

NOTE: Locate the control box underneath the countertop, between the ell and the water supply stop.

NOTE: Do not connect the control box wiring in this step.

- Drill a 1/2" (13 mm) hole at the control box location.
- Route the sensor wire through the hole.
- Remove the control box cover. Set the screws and cover aside.
- Feed the wires through the back of the control box.
- Mark the screw hole locations using the control box as a template. Make sure the wire harness hole in the wall is covered by the box.
- Install appropriate wall anchors (not provided) at the marked hole locations.
- Attach the control box to the wall with two screws (not provided).

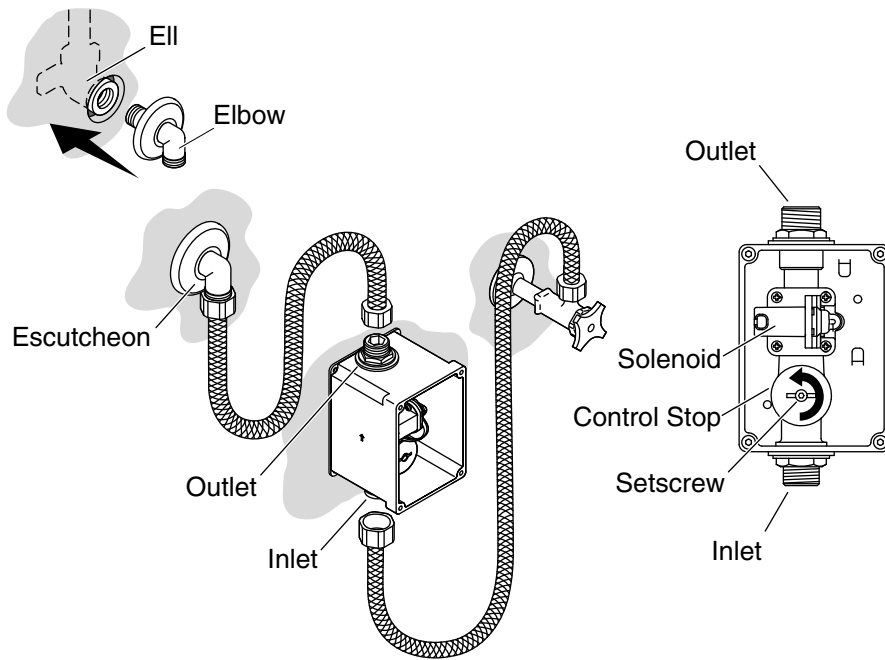

8. Install the Supply Hoses

IMPORTANT! It is critical that the inlet and outlet holes be aligned correctly. The outlet is identified with a label on the top of the control box.

- ❑ Slide the escutcheon over the elbow and attach the elbow to the wall.
- ❑ Slide the escutcheon tight against the wall.
- ❑ Attach one end of the hose to the elbow and attach the other end of the hose to the control box outlet.
- ❑ Attach the supply hose to the control box inlet.
- ❑ Verify that the control stop is fully open by turning the setscrew counterclockwise.

NOTE: If the water supply does not route through a mixing valve, the water from the faucet will be cold.

- ❑ Attach the other end of the line to a thermostatic mixing valve (recommended), mixing valve, or supply stop.

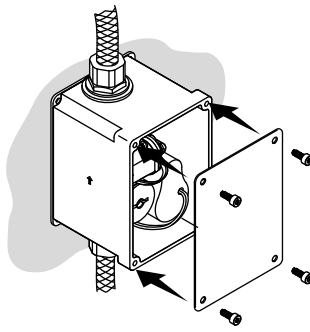
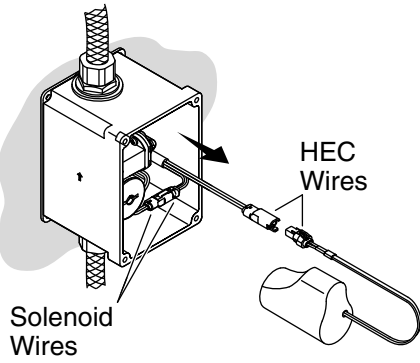

9. Install the Hybrid Energy Cell

IMPORTANT! Avoid the area in front of the sensor for 2 minutes after the connections are complete. If the sensor was triggered within 2 minutes, disconnect and reconnect the power to reset the sensor.

- Connect the solenoid wires (green and red).
- Connect the Hybrid Energy Cell (HEC) wires (black and orange).
- Position the wires so they do not get pinched.
- Reinstall the cover with the four screws.
- Allow 2 minutes for the sensor to cycle through the automatic sensing distance.

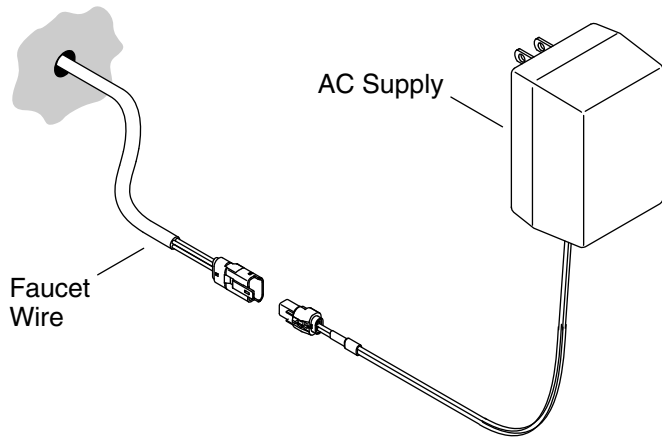

10. AC Power - Single Faucet

IMPORTANT! The area in front of the sensor must be free of objects during the 2 minute learning cycle or the faucet may not function properly.

- Connect the faucet wire to the AC supply.
- Plug the AC supply into the wall outlet.
- Secure any excess wire under the counter.
- Allow 2 minutes for the sensor to cycle through the automatic sensing distance.

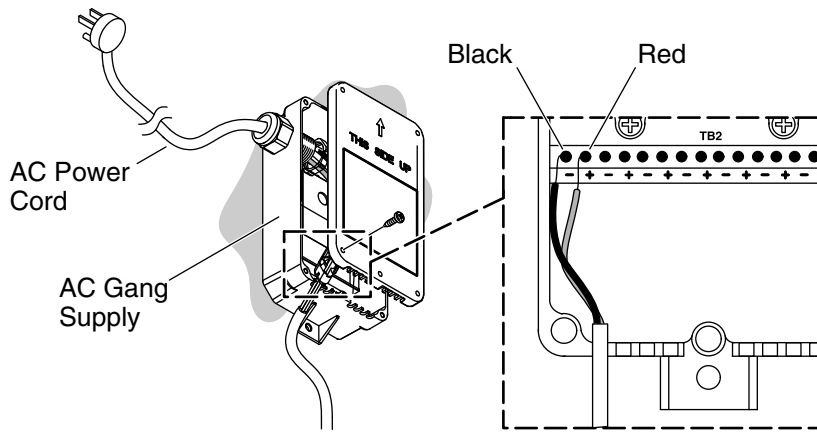

11. AC Power - Multiple Faucet



CAUTION: Risk of electric shock. Make sure the power has been disconnected before performing the following procedures.

IMPORTANT! The area in front of the sensor must be free of objects during the 2 minute learning cycle or the faucet may not function properly.

- Mount the AC gang supply under the counter using two screws (not supplied). Orient as shown.
- Remove the cover.
- If needed, cut and strip the ends of faucet wires to length.
- Connect the stripped ends to the bottom terminal block (TB2) in the AC gang supply.

NOTE: If a hard wired installation is required, proceed to the "Hard Wire Installations" section.

- Plug the AC power cord into the wall outlet.
- Secure any excess wire under the counter.
- Allow 2 minutes for the sensor to cycle through the automatic sensing distance.

Hard Wire Installations

AC Power - Multiple Faucet (cont.)



WARNING: Risk of electrical shock. Make sure the power has been disconnected before performing the following procedures.

IMPORTANT! In this application the multi-outlet supply must be permanently connected. Remove and discard the included mounting bracket.

NOTE: Suitable input wiring will have two 14 AWG conductors with ground, rated 60C.

- Remove the cover.
- Loosen the terminal block screws in TB1 and remove the power cord from the top terminal block.
- Remove the existing strain relief connector and replace it with a strain relief connector compatible with the new wiring system.
- Loosen the outside nut of the strain relief and remove the power cord.
- Run suitable wire through the strain relief and enclosure hole into the terminal block.
- Connect the conductors to terminal block (TB1) and tighten to 7 in lbs (.8 Nm).
- Tighten the strain relief following the manufacturer's instructions.
- Attach the faucet wire connector to the faucet.
- Connect the stripped ends of the faucet wires into the low voltage terminal block (TB2). Connect the black wire to negative (-) and red wire to positive (+). Tighten terminal block screws to 7 in lbs (.8 Nm).
- Replace the cover, and secure with the screws.
- Secure any extra wire under the counter.
- Connect the power and install the faucet.
- Allow 2 minutes for the sensor to cycle through the automatic sensing distance.

12. Complete the Installation

NOTE: Avoid the area in front of the sensor for 2 minutes after connections are complete. The sensor will not function correctly if it is triggered in the first 2 minutes. Disconnect and reconnect the power to reset the sensor.

- Install the faucet trim following the directions provided.

Complete the Installation (cont.)

- Turn the water on to test the faucet.
- Check for leaks.