





HEKMAN

ASSEMBLY INSTRUCTIONS

24304-Rec Coggee Table

A HOWARD MILLER COMPANY

HARDWARE LIST				
NO.	DESCRIPTION	SKETCH	DIMENSION	QTY
1		ALLEN KEY	5MMxL75mm	1pc
2		LOCK WASHER	Ø5/16"	12pcs
3		FLAT WASHER	Ø5/16"(19mm)	12pcs
4		BOLT	Ø5/16"x 37mm	8pcs
5		BOLT	Ø5/16"x 19mm	4pcs

STEP 1 Lay Top Panel Face Down on a soft clean surface.

STEP 2 Attach metal Legs to the top panel with Bolt #4, Lock washer #2, and Flat Washer #3, do not tighten these Bolt at this time

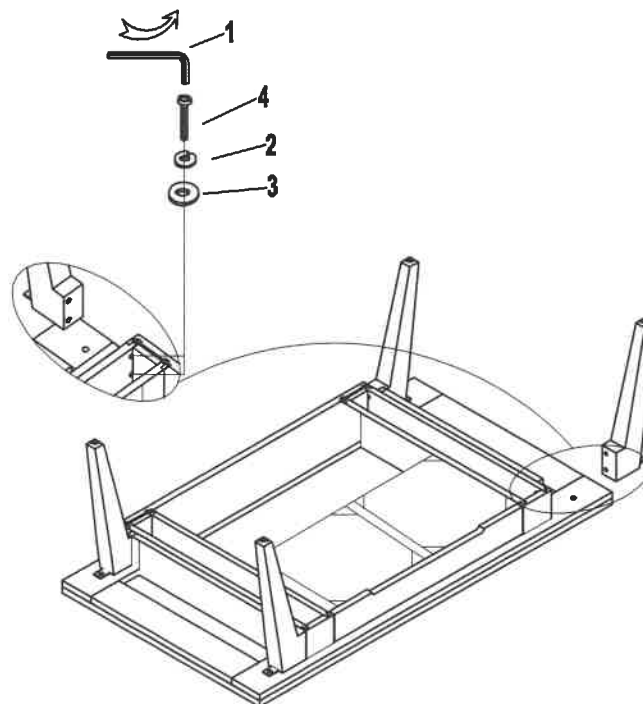

MADE IN VIETNAM

HEKMAN

ASSEMBLY INSTRUCTIONS

24304-Rec Cogee Table

STEP 3 Using more Bolt #5, Lock washer #2, and Flat Washer #3 to attach Legs to the Top

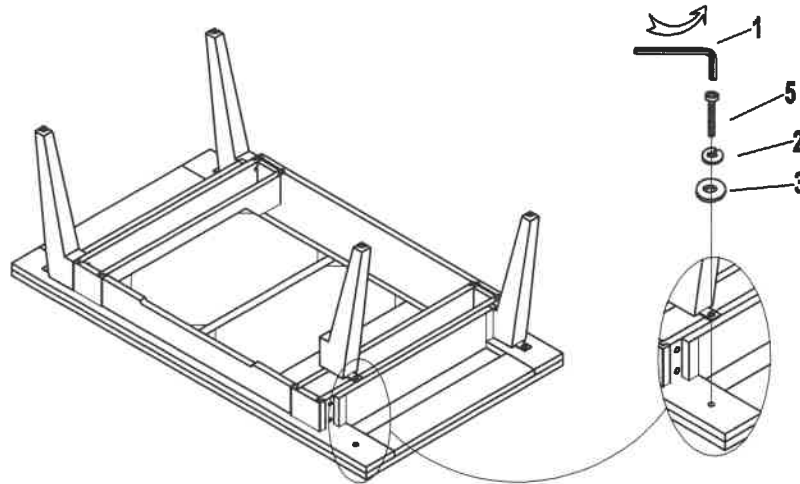

STEP 4 Tighten all Bolts with Allen Wrench #1

STEP 5 Turn table upright,

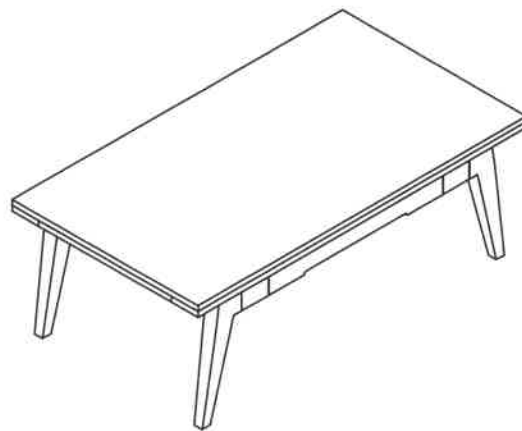

MADE IN VIETNAM