

Low Voltage Connection Board

REPLACEMENT INSTRUCTIONS

Kit Name	Low Voltage Board Kit
Kit Part Number	803000111
Compatible Rinnai Products	Rinnai Commercial Boiler Models: RCB500AN, RCB750AN & RCB1000AN

WARNING Failure to correctly assemble the components according to these instructions may result in electric shock, injury, or death.

CAUTION

To protect yourself from harm, follow the steps below before proceeding.

- Disconnect the electrical power supply by turning off the circuit breaker.
- Shut off the gas at the gas valve, usually located near the gas connection at the appliance.
- Turn off the water by closing manual ball valves at the return and supply piping connections at the appliance.

Items Inside Product Box

Before installation, please make sure all parts are located inside the product box.

Table 1

Item #	Item (Part Number)	Qty
1	Low Voltage Board	1
2	Screw, M3 X 8mm (809000375)	5

TOOLS/MATERIALS REQUIRED

- Phillips head screwdriver #1
- Flat head screwdriver

Instructions

1. Turn off and disconnect 120 V power supply.
2. Turn off water supply.
3. Turn off gas supply.

Figure 1

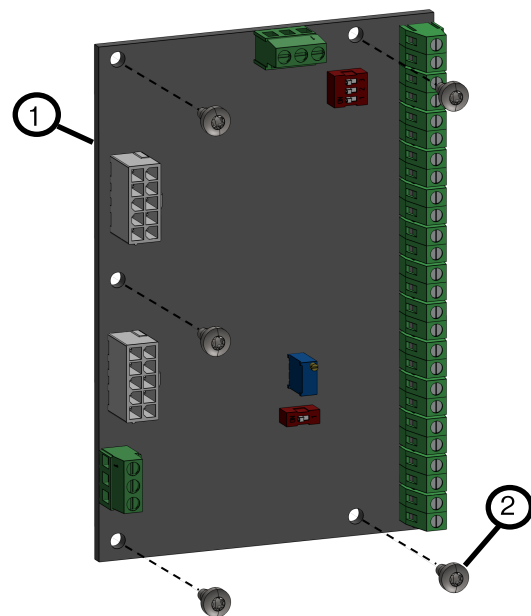

CAUTION Confirm gas valve is turned off and not leaking.

4. **RCB500AN:** Use a Phillips head screwdriver to remove four (4) screws securing the angle panel around the display assembly (Figure 2A). Place the screws and panel in a safe location until they are needed for re-assembly.
5. **RCB500AN:** Use a Phillips head screwdriver to remove two (2) screws securing the front panel (Figure 2B). Slide the panel up to clear the pins on the bottom, then pull it out to remove it from the boiler. Place the screws and panel in a safe location until they are needed for re-assembly.
6. **RCB500AN:** Remove two (2) screws for right side panel from the front side of the boiler, then rotate the side panel out to clear the bottom part of the side panel (Figure 3A).
7. **RCB500AN:** Pull the panel forward to clear the locking mechanism on the back side then pull the panel out (Figure 3B). Place the screws and panel in a safe location until they are needed for re-assembly.

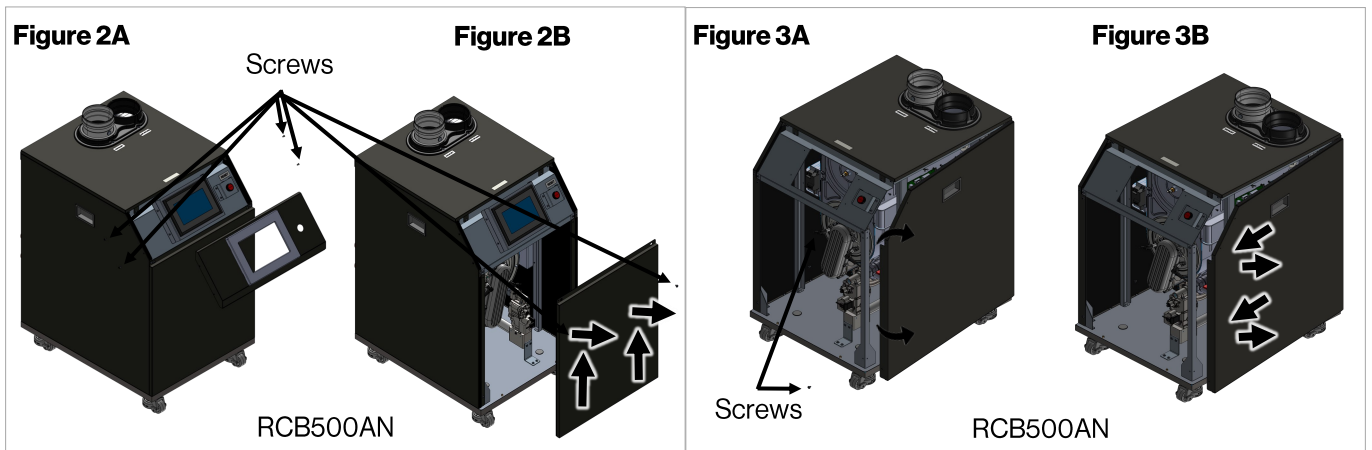

8. **RCB 750AN & RCB 1000AN:** Use the provided key on the back of the boiler to turn the quarter turn locks toward the inside of the panel to unlock the right side panels (figure 4A).
9. **RCB 750AN & RCB 1000AN:** Use handle to lift both right side panels in order for the hooks to clear the slots holding the side panels in place (Figure 4B). Place it safe location until it is needed for re-assembly.
10. **RCB 750AN & RCB 1000AN:** Pull the panels out and remove them from the boiler (Figure 4B). Place the panel in a safe location until it is needed for re-assembly.

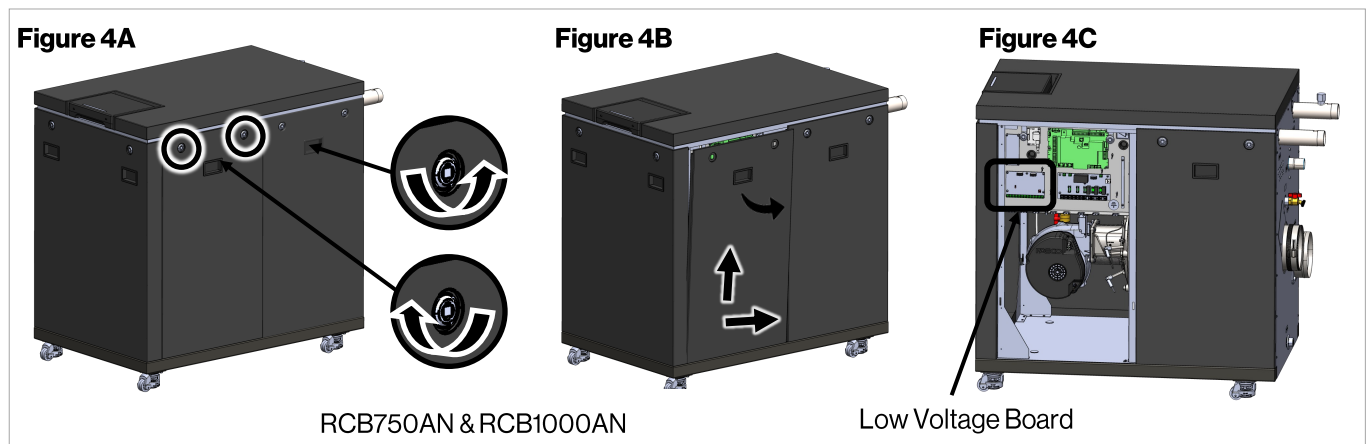

11. After removing the side panel, locate the Low Voltage Board inside the metal enclosure (Figure 4C/5A).
12. Ensure that all the PCB connectors are labeled for identification during re-assembly. Disconnect all the connectors (Figure 6).
13. Use a Phillips head screwdriver to remove five (5) screws securing the Low Voltage Board (Figure 5B).

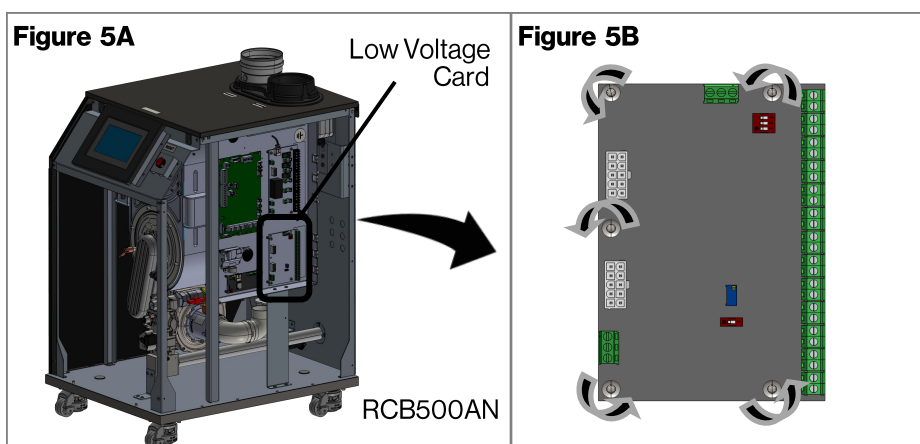
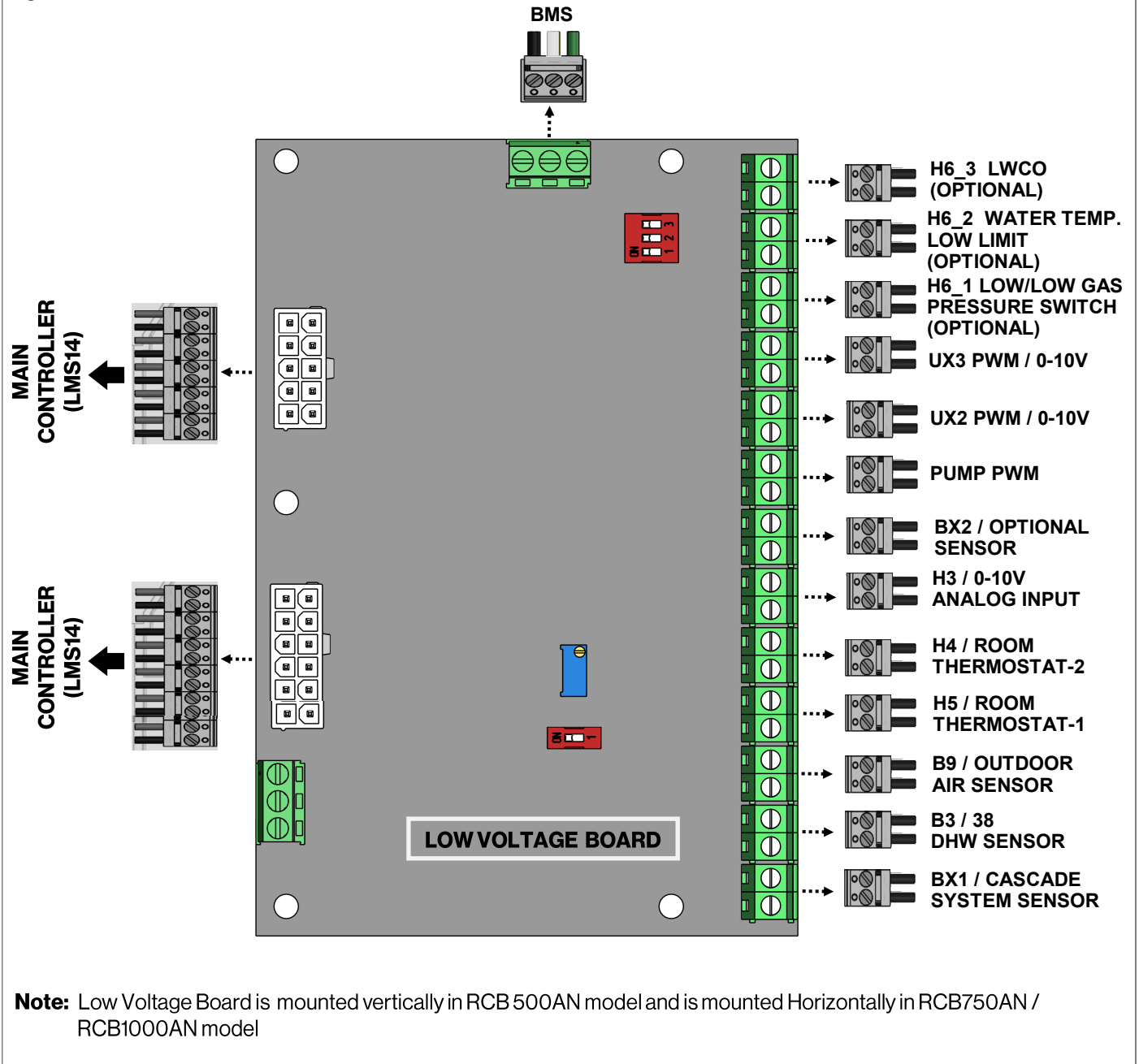

Figure 6



Low Voltage Board Connection Reassembly

1. Install the new Low Voltage Board inside of the metal enclosure using new screws (Figure 5A & 5B)
2. Install all connectors and wires into their respective position in the new Low Voltage Board (Figure 6).
3. Reconnect and turn on 120 V power supply, water supply and gas supply.
4. Test the new Low Voltage Board functionality.
5. **RCB500AN:** After all checks have been successfully completed, reinstall all panels in the reverse order they were disassembled (Figures 2A, 2B, 3A & 3B).
6. **RCB750AN & RCB1000AN:** After all checks have been successfully completed, reinstall all panels in the reverse order they were disassembled (Figures 4A, 4B & 4C).