





ASSEMBLY INSTRUCTION FOR 24203 LAMP TABLE

HARDWARE LIST

NO.	ITEM	DESCRIPTIN	QTY.
1		JCB Bolt M6 X 20 MM	8
2		Allen key	1
3		HEX Bolt M8X20 MM	4
4		Flat washer M8X25 MM	4
5		Wrench	1

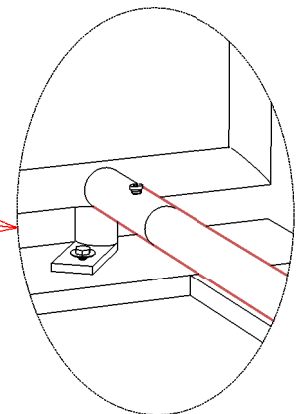
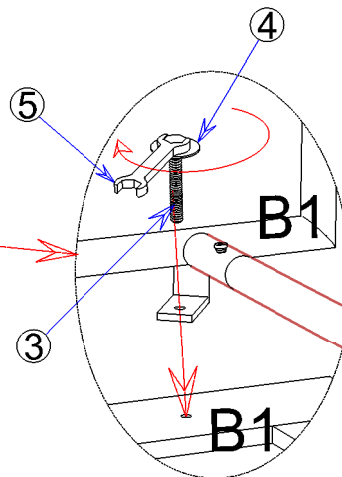
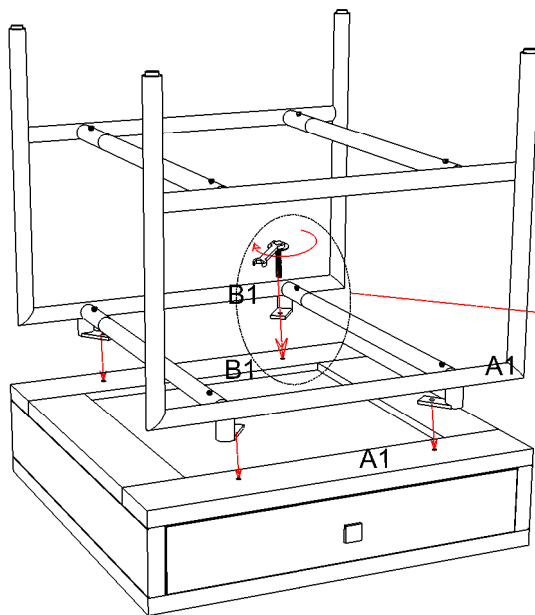
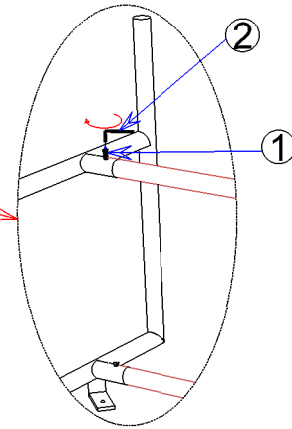
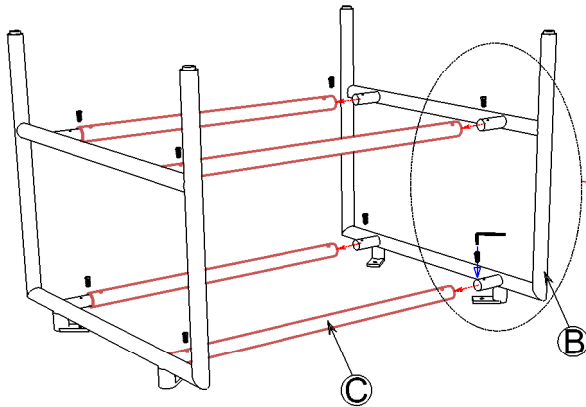
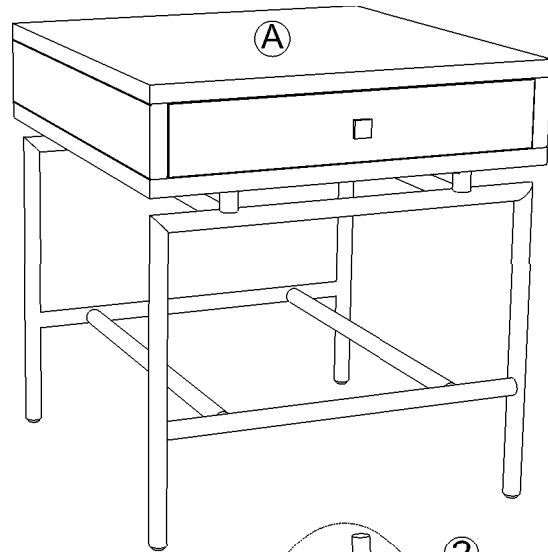

TO ASSEMBLY :

STEP 1 : Unpack lamp table.

STEP 2 : Assemble iron leg assemblies 'B' to cross iron bar 'C' using JCB bolt (1) Tighten the bolt fully.

STEP 3 : Set iron base assembly on the upside down lamp table wooden top (A), and fix with HEX bolt (3) and washer (4) using wrench (5) matching the numbers A1-A1 & B1-B1.

STEP 4 : Tighten bolts in step 3 fully with wrench (5) then carefully turn the lamp table upright.