

BLACK DIAMOND®

Project Name: _____

Location: _____

Item #: _____

Qty: _____

Black Diamond Energy Star Gas Deep Fryer, 35 lb, 65K BTU, in Stainless Steel

BDGF-ES35-LP



The Black Diamond Energy Star Gas Deep Fryer offers a robust 35 lb oil capacity and a high-output 65,000 BTU performance for fast, reliable frying in demanding commercial kitchens. Constructed from durable 16-gauge stainless steel, this floor model excels in high-volume applications, such as restaurants, bars, and cafeterias. Its broad temperature range of 200°F to 400°F and automatic shut-off promote food consistency and operational safety. Designed for use with liquid propane, the fryer supports a range of fried options—from French fries to chicken wings—while its twin wire baskets and accessories maximize productivity. Backed by a one-year parts and labor warranty and a five-year stainless steel fry pot warranty, this fryer combines energy efficiency, safety features, and lasting value for any busy foodservice environment.

FEATURES AND CONSTRUCTION

- Best-in-class, energy-efficient design with Energy Star Certification
- Constructed of heavy-duty 16-gauge stainless steel for unmatched durability and long-term use
- Delivers 65,000 BTU for fast heat recovery and superior cooking performance in high output kitchens
- Features three high-performance burners with standing pilot for consistent and even frying
- Manual controls ensure precise adjustment for temperature and operation, suited for commercial environments
- Uses liquid propane (LP) for efficient, high-volume frying with consistent results
- Freestanding installation accommodates flexible placement and access in busy commercial kitchens
- Manual ignition with standing pilot light enables reliable and instant startup every service

FRYER ACCESSORIES (OPTIONAL)

- Stainless Steel Cover
- Joiner Strips
- Splash Guard
- Fryer baskets available in a variety of sizes

3RD PARTY APPROVALS



WARRANTY (USA / CANADA)

One (1) Year Limited Warranty on Parts and Labor, Five (5) Year Warranty on Stainless Steel Fry Tank

Contact us for details at 1.877.368.2797



INCLUDED COMPONENTS

- (4) Casters, (2) Baskets, (1) Basket Support Rack, (1) Basket Hanging Plate, (1) Oil Drainage Extension Pipe

TEMPERATURE

Overall Temperature (Fahrenheit):

- Minimum: 200° - Maximum: 400°F



Black Diamond Energy Star Gas Deep Fryer

BDGF-ES35-LP

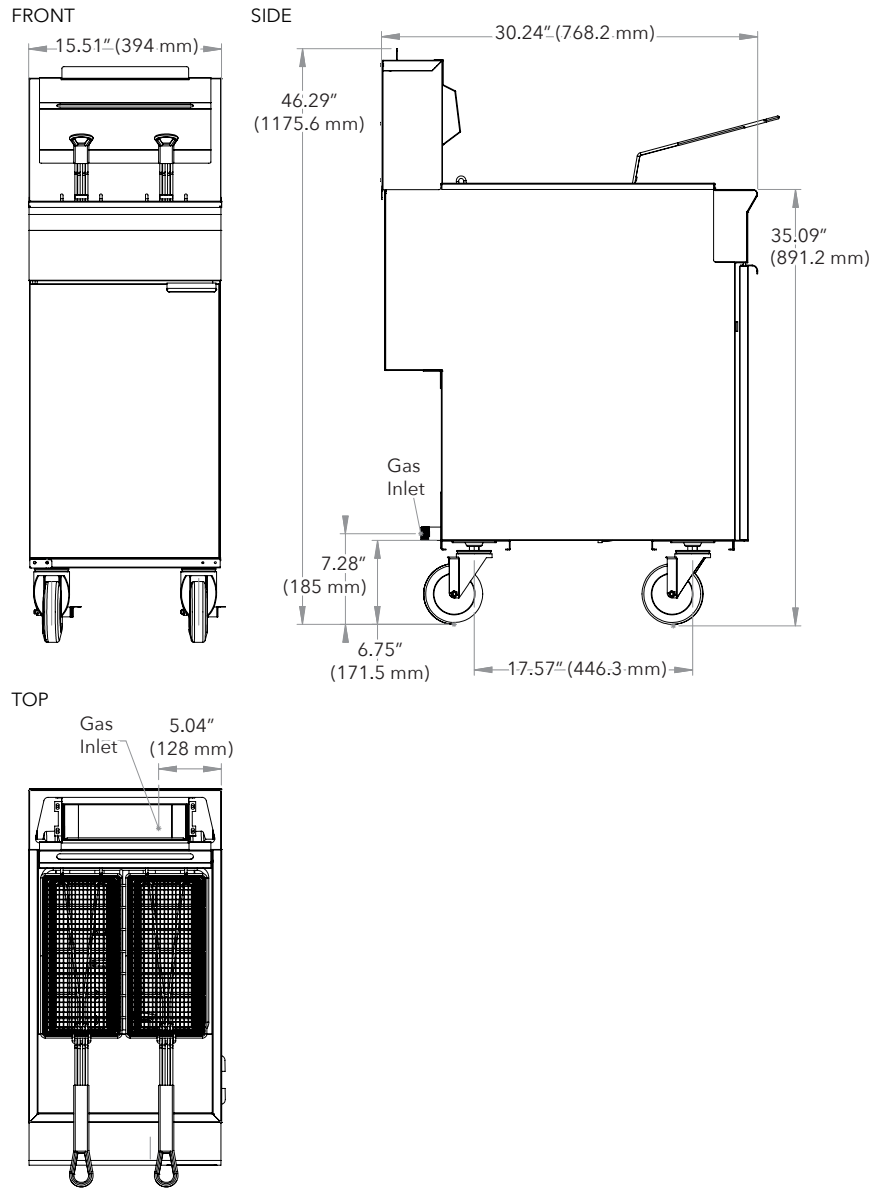

Gas

Capacity (lbs. of oil)	Temperature Range (Fahrenheit)	BTU / Hour	Assembled Dimensions (in)	Item Weight (lbs)	Shipping Weight (lbs)
------------------------	--------------------------------	------------	---------------------------	-------------------	-----------------------

35 lb	200° - 400°	65000	30.24" x 15.51" x 46.29"	134.2	154.0
-------	-------------	-------	--------------------------	-------	-------

ADDITIONAL INFORMATION

- Electricity not needed.
- Liquid Propane (LP) or Natural Gas (NG) units available. Field convertible from LP to NG and vice versa.
- Minimum supply pressure is 4" W.C. for natural gas and 10" W.C. for propane.
- Gas powered appliances must always be indoors, under an approved exhaust system with grease removal filters and a fire protection system.

Due to periodic changes in designs, methods, procedures, policies and regulations, the specifications contained in this document are subject to change without notice. While we exercise good faith efforts to provide information that is accurate, we are not responsible for errors or omissions in information provided or conclusions reached as a result of using the specifications. By using the information provided, the user assumes all risks in connection with such use.